

## FOREWORD

This wiring diagram manual has been prepared to provide information on the electrical system of the 2007 CAMRY.

Applicable models: GSV40 Series  
ACV40 Series

Refer to the following manuals for additional service specifications and repair procedures for these models:

| Manual Name                   | Pub. No. |
|-------------------------------|----------|
| ● 2007 CAMRY Repair Manual    | RM0250U  |
| ● 2007 CAMRY New Car Features | NM0250U  |

All information in this manual is based on the latest product information at the time of publication. However, specifications and procedures are subject to change without notice.

**TOYOTA MOTOR CORPORATION**

### NOTICE

**Always follow the directions given in the above repair manuals when handling supplemental restraint system components (such as removal, installation, inspection, etc.) in order to prevent accidents and supplemental restraint system malfunction.**

©2006 TOYOTA MOTOR CORPORATION

All rights reserved. This book may not be reproduced or copied, in whole or in part, without the written permission of Toyota Motor Corporation.

First Printing : Jan. 13, 2006 01-060113-00

# 2007 CAMRY ELECTRICAL WIRING DIAGRAM

|   | Section Code | Page |
|---|--------------|------|
| INTRODUCTION .....                      | A .....      | 2    |
| HOW TO USE THIS MANUAL .....            | B .....      | 3    |
| TROUBLESHOOTING .....                   | C .....      | 12   |
| ABBREVIATIONS .....                     | D .....      | 17   |
| GLOSSARY OF TERMS AND SYMBOLS .....     | E .....      | 18   |
| RELAY LOCATIONS .....                   | F .....      | 20   |
| ELECTRICAL WIRING ROUTING .....         | G .....      | 48   |
| SYSTEM CIRCUITS .....                   | H .....      | 70   |
| GROUND POINT .....                      | I .....      | 396  |
| POWER SOURCE (Current Flow Chart) ..... | J .....      | 404  |
| CONNECTOR LIST .....                    | K .....      | 414  |
| PART NUMBER OF CONNECTORS .....         | L .....      | 436  |
| OVERALL ELECTRICAL WIRING DIAGRAM .     | M .....      | 440  |

# A INTRODUCTION

This manual consists of the following 13 sections:

| No. | Section                           | Description   |
|-----|-----------------------------------|---|
| A   | INDEX                             | Index of the contents of this manual.   |
|     | INTRODUCTION                      | Brief explanation of each section.  |
| B   | HOW TO USE THIS MANUAL            | Instructions on how to use this manual.   |
| C   | TROUBLE-SHOOTING                  | Describes the basic inspection procedures for electrical circuits.  |
| D   | ABBREVIATIONS                     | Defines the abbreviations used in this manual.  |
| E   | GLOSSARY OF TERMS AND SYMBOLS     | Defines the symbols and functions of major parts.   |
| F   | RELAY LOCATIONS                   | Shows position of the Electronic Control Unit, Relays, Relay Block, etc. This section is closely related to the system circuit.   |
| G   | ELECTRICAL WIRING ROUTING         | Describes position of Parts Connectors, Splice points, Ground points, etc. This section is closely related to the system circuit.   |
| H   | INDEX                             | Index of the system circuits.   |
|     | SYSTEM CIRCUITS                   | Electrical circuits of each system are shown from the power supply through ground points. Wiring connections and their positions are shown and classified by code according to the connection method. (Refer to the section, "How to use this manual"). The "System Outline" and "Service Hints" useful for troubleshooting are also contained in this section. |
| I   | GROUND POINT                      | Shows ground positions of all parts described in this manual.   |
| J   | POWER SOURCE (Current Flow Chart) | Describes power distribution from the power supply to various electrical loads.   |
| K   | CONNECTOR LIST                    | Describes the form of the connectors for the parts appeared in this book. This section is closely related to the system circuit.  |
| L   | PART NUMBER OF CONNECTORS         | Indicates the part number of the connectors used in this manual.  |
| M   | OVERALL ELECTRICAL WIRING DIAGRAM | Provides circuit diagrams showing the circuit connections.  |

This manual provides information on the electrical circuits installed on vehicles by dividing them into a circuit for each system.

The actual wiring of each system circuit is shown from the point where the power source is received from the battery as far as each ground point. (All circuit diagrams are shown with the switches in the OFF position.)

When troubleshooting any problem, first understand the operation of the circuit where the problem was detected (see System Circuit section), the power source supplying power to that circuit (see Power Source section), and the ground points (see Ground Point section). See the System Outline to understand the circuit operation.

When the circuit operation is understood, begin troubleshooting of the problem circuit to isolate the cause. Use Relay Location and Electrical Wiring Routing sections to find each part, junction block and wiring harness connectors, wiring harness and wiring harness connectors and ground points of each system circuit. Internal wiring for each junction block is also provided for better understanding of connection within a junction block.

Wiring related to each system is indicated in each system circuit by arrows (from\_\_, to\_\_). When overall connections are required, see the Overall Electrical Wiring Diagram at the end of this manual.

# B HOW TO USE THIS MANUAL

\* The system shown here is an EXAMPLE ONLY. It is different to the actual circuit shown in the SYSTEM CIRCUITS SECTION.

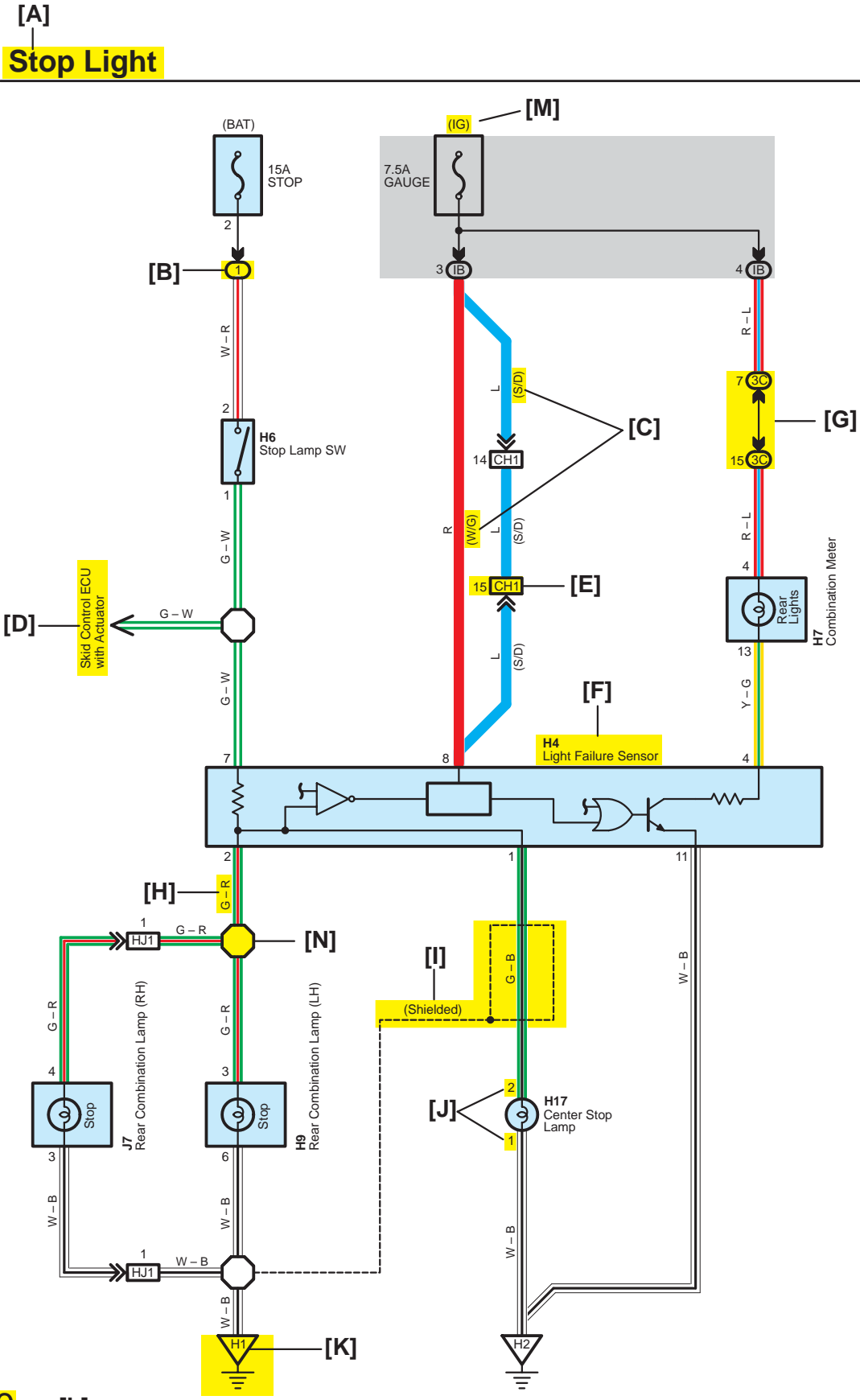

50 — [L]

**[A]** : System Title

**[B]** : Indicates a Relay Block. No shading is used and only the Relay Block No. is shown to distinguish it from the J/B

Example: ① Indicates Relay Block No.1

**[C]** : ( ) is used to indicate different wiring and connector, etc. when the vehicle model, engine type, or specification is different.

**[D]** : Indicates related system.

**[E]** : Indicates the code for the (male and female) connectors which are used to join two wire harnesses. The connector code consists of two alphabetical and one numerical characters.

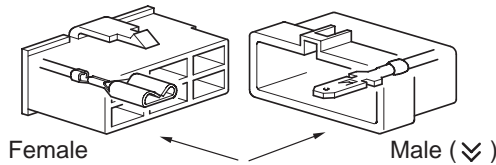

The first character of the connector code indicates the alphabetical code allocated to the wire harness which has the female connector, and the second shows that of the wire harness which has the male connector.

The third character indicates a serial number used to distinguish between the wire harness combinations in cases when more than one of the same combination of wire harnesses exist (e.g. CH1 and CH2).

Symbol (∨) indicates the male terminal connector. Numbers outside connector codes indicate the pin numbers of both male and female connectors.

**[F]** : Represents a part (all parts are shown in sky blue). The code is the same as the code used in parts position.

**[G]** : Junction Block (The number in the circle is the J/B No. and the connector code is shown beside it). Junction Blocks are shaded to clearly separate them from other parts.

Example:

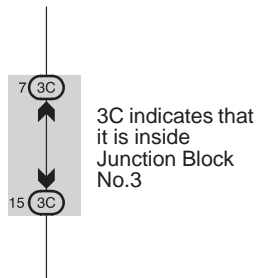

**[H]** : Indicates the wiring color.

Wire colors are indicated by an alphabetical code.

- B = Black    W = White    BR = Brown
- L = Blue    V = Violet    SB = Sky Blue
- R = Red    G = Green    LG = Light Green
- P = Pink    Y = Yellow    GR = Gray
- O = Orange

The first letter indicates the basic wire color and the second letter indicates the color of the stripe.

Example: L - Y

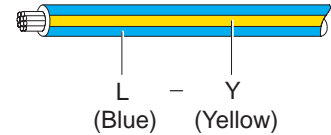

**[I]** : Indicates a shielded cable.



**[J]** : Indicates the pin number of the connector. The numbering system is different for female and male connectors.

Example: Numbered in other from upper left to lower right

Numbered in other from upper right to lower left

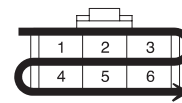

Female

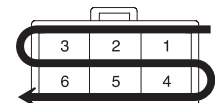

Male

**[K]** : Indicates the ground point. The code consists of the two characters: A letter and number.

The first character of the code indicates the alphabetical code allocated to the wire harness. The second character indicates a serial number used to distinguish between the ground points in cases when more than one ground point exist on the same wire harness.

**[L]** : Page No.

**[M]** : Indicates the ignition key position(s) when the power is supplied to the fuse(s).

**[N]** : Indicates a wiring Splice Point.

Example:

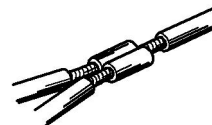

## B HOW TO USE THIS MANUAL

### [O] **System Outline**

Current is applied at all times through the STOP fuse to TERMINAL 2 of the stop lamp SW.  
When the ignition SW is turned on, current flows from the GAUGE fuse to TERMINAL 8 of the light failure sensor, and also flows through the rear lights warning light to TERMINAL 4 of the light failure sensor.

#### **Stop Light Disconnection Warning**

When the ignition SW is turned on and the brake pedal is pressed (Stop lamp SW on), if the stop light circuit is open, the current flowing from TERMINAL 7 of the light failure sensor to TERMINALS 1, 2 changes, so the light failure sensor detects the disconnection and the warning circuit of the light failure sensor is activated.

As a result, the current flows from TERMINAL 4 of the light failure sensor to TERMINAL 11 to GROUND and turns the rear lights warning light on. By pressing the brake pedal, the current flowing to TERMINAL 8 of the light failure sensor keeps the warning circuit on and holds the warning light on until the ignition SW is turned off.

### [P] **○ : Parts Location**

| Code | See Page | Code | See Page | Code | See Page |
|------|----------|------|----------|------|----------|
| H4   | 36       | H7   | 36       | H17  | 38       |
| H6   | 36       | H9   | 38       | J7   | 38       |

### [Q] **○ : Relay Blocks**

| Code | See Page | Relay Blocks (Relay Block Location)  |
|------|----------|--------------------------------------|
| 1    | 18       | R/B No.1 (Instrument Panel Brace LH) |

### [R] **○ : Junction Block and Wire Harness Connector**

| Code | See Page | Junction Block and Wire Harness (Connector Location)                |
|------|----------|---|
| 3C   | 22       | Instrument Panel Wire and J/B No.3 (Instrument Panel Brace LH)      |
| IB   | 20       | Instrument Panel Wire and Instrument Panel J/B (Lower Finish Panel) |

### [S] **□ : Connector Joining Wire Harness and Wire Harness**

| Code | See Page | Joining Wire Harness and Wire Harness (Connector Location)        |
|------|----------|---|
| CH1  | 42       | Engine Room Main Wire and Instrument Panel Wire (Left Kick Panel) |
| HJ1  | 50       | Instrument Panel Wire and Floor Wire (Right Kick Panel)           |

### [T] **▽ : Ground Points**

| Code | See Page | Ground Points Location       |
|------|----------|------------------------------|
| H1   | 50       | Under the Left Center Pillar |
| H2   | 50       | Back Panel Center            |

**[O]** : Explains the system outline.

**[P]** : Indicates reference pages showing the parts locations in the system circuit on the vehicle.

Example : Code "H4" (Light Failure Sensor) is on page 36 of the manual.

\* The first character of the code indicates the alphabetical code allocated to the wire harness, and the second character indicates the serial number of the parts connected to the wire harness.

Example : H 4  
          └──┬── Serial number for the connected parts  
             └── Code for the wire harness

**[Q]** : Indicates the reference page showing the position on the vehicle of Relay Block Connectors in the system circuit.

Example : Connector "1" is described on page 18 of this manual and is installed on the left side of the instrument panel.

**[R]** : Indicates the reference page showing the position on the vehicle of J/B and Wire Harness in the system circuit.

Example : Connector "3C" connects the Instrument Panel Wire and J/B No.3. It is described on page 22 of this manual, and is installed on the instrument panel left side.

**[S]** : Indicates the reference page describing the wiring harness and wiring harness connector (the female wiring harness is shown first, followed by the male wiring harness).

Example : Connector "CH1" connects the Engine Room Main Wire (female) and Instrument Panel Wire (male). It is described on page 42 of this manual, and is installed on the left side kick panel.

**[T]** : Indicates the reference page showing the position of the ground points on the vehicle.

Example : Ground point "H2" is described on page 50 of this manual and is installed on the back panel center.



# B HOW TO USE THIS MANUAL

The ground points circuit diagram shows the connections from all major parts to the respective ground points. When troubleshooting a faulty ground point, checking the system circuits which use a common ground may help you identify the problem ground quickly. The relationship between ground points (  $\nabla A1$  ,  $\nabla A2$  and  $\nabla D4$  shown below) can also be checked this way.

## I GROUND POINT

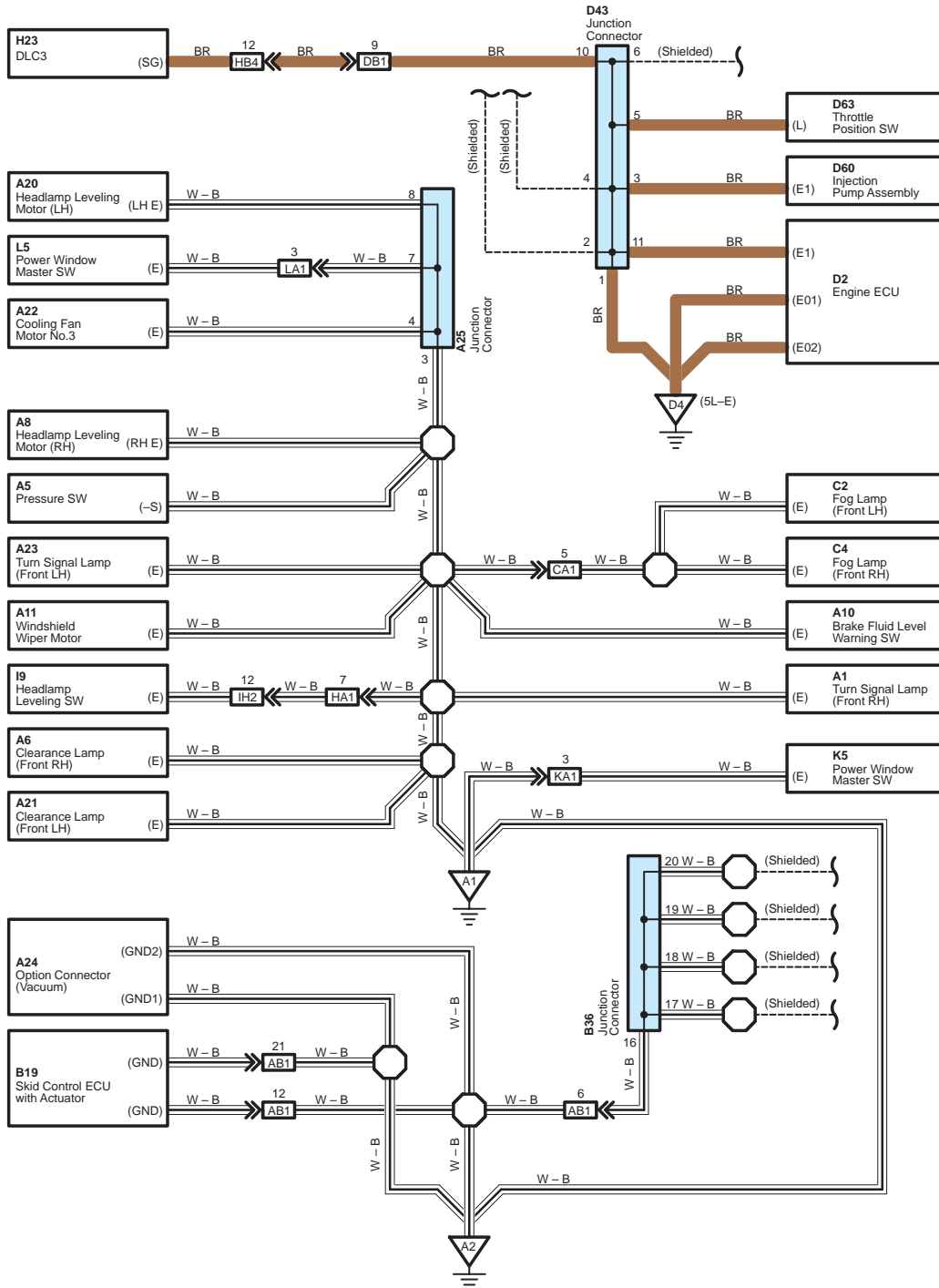

\* The system shown here is an EXAMPLE ONLY. It is different to the actual circuit shown in the SYSTEM CIRCUITS SECTION.

The "Current Flow Chart" section, describes which parts each power source (fuses, fusible links, and circuit breakers) transmits current to. In the Power Source circuit diagram, the conditions when battery power is supplied to each system are explained. Since all System Circuit diagrams start from the power source, the power source system must be fully understood.

## J POWER SOURCE (Current Flow Chart)

The chart below shows the route by which current flows from the battery to each electrical source (Fusible Link, Circuit Breaker, Fuses, etc.) and other parts

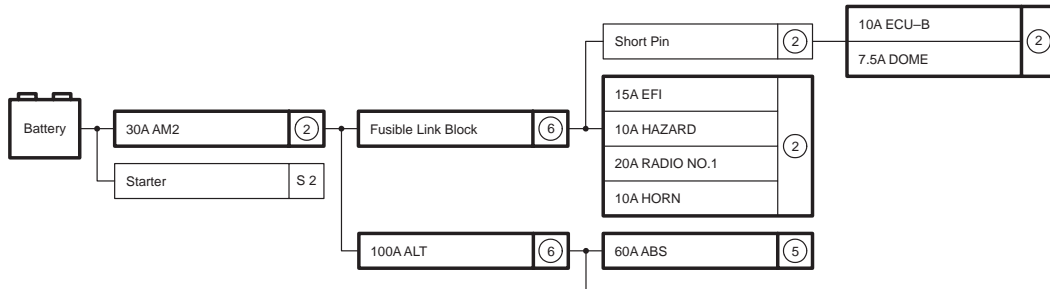

### Engine Room R/B (See Page 20)

| Fuse | System | Page                                   |     |
|------|--------|--|-----|
| 20A  | STOP   | ABS                                    | 194 |
|      |        | ABS and Traction Control               | 187 |
|      |        | Cruise Control                         | 180 |
|      |        | Electronically Controlled Transmission | 166 |
|      |        | Multiplex Communication System         | 210 |
| 10A  | DOME   | Cigarette Lighter                      | 214 |
|      |        | Combination Meter                      | 230 |
|      |        | Headlight                              | 112 |
|      |        | Interior Light                         | 122 |
|      |        | Key Reminder and Seat Belt Warning     |     |
|      |        | Light Auto Turn Off System             |     |

### Power Source

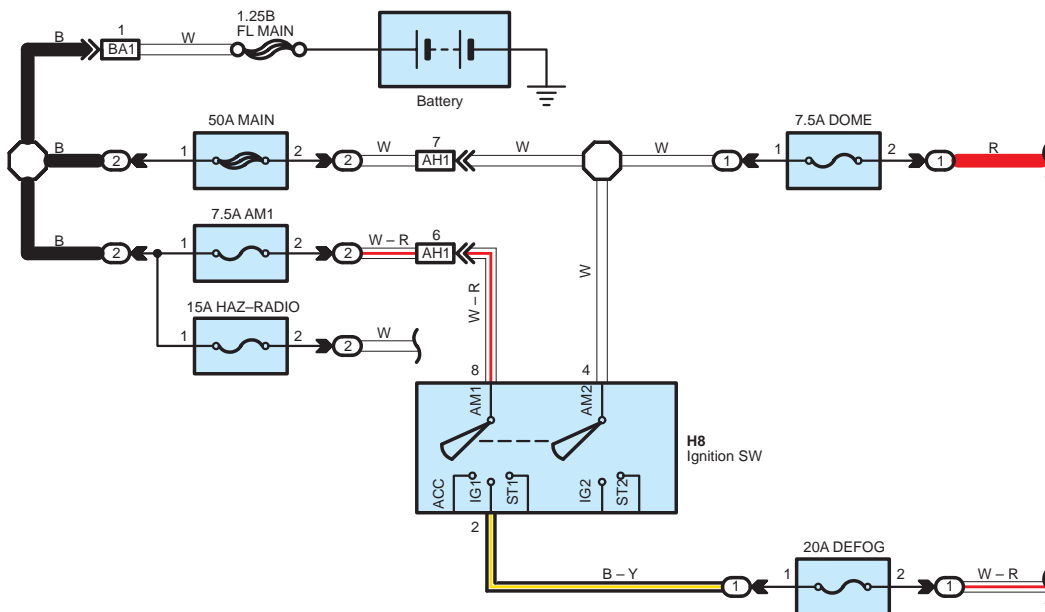

\* The system shown here is an EXAMPLE ONLY. It is different to the actual circuit shown in the SYSTEM CIRCUITS SECTION.

## B HOW TO USE THIS MANUAL

### K CONNECTOR LIST

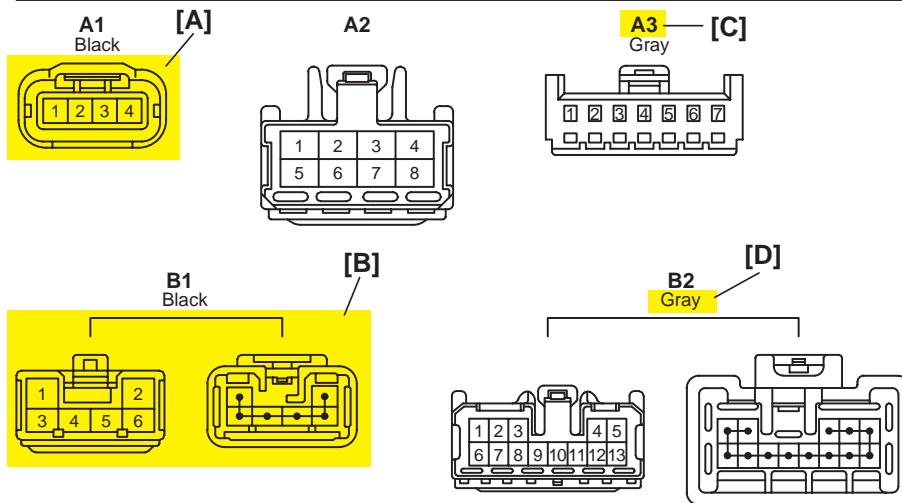

### K CONNECTOR LIST

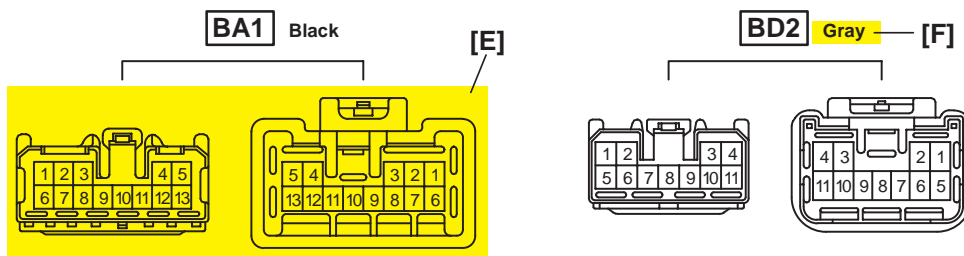

**[A]** : Indicates connector to be connected to a part. (The numeral indicates the pin No.)

**[B]** : Junction Connector  
Indicates a connector which is connected to a short terminal.

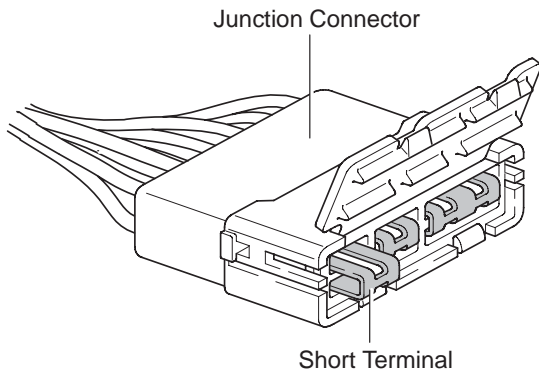

Junction connector in this manual include a short terminal which is connected to a number of wire harnesses. Always perform inspection with the short terminal installed.

**[C]** : Parts Code  
The first letter of the code is taken from the first letter of part, and the numbers indicates its order in parts which start with the same letter.

**[D]** : Connector Color  
Connectors not indicated are milky white in color.

**[E]** : Indicates the connector shapes which are used to join wire harnesses.  
On Left : Female connector shapes  
On Right : Male connector shapes  
Numbers indicate pin numbers.

**[F]** : Indicates connector colors. (Connectors with not indicated colors are white)

## L PART NUMBER OF CONNECTORS

| Code | Part Name                    | Part Number | Code | Part Name                     | Part Number |
|------|------------------------------|-------------|------|-------------------------------|-------------|
| A1   | Turn Signal Lamp (Front RH)  | 90980-11019 | B22  | Door Courtesy SW (Front LH)   | 90980-12470 |
| A2   | Inlet Air Temp. Sensor       | 90980-11163 | B23  | Front Seat Outer Belt (LH)    | 90980-12253 |
| A3   | Air Flow Meter               | 90980-12292 | B24  | Blower SW (Rear Heater)       | 90980-10463 |
| A4   | A/C Pressure Sensor          | 90980-10845 | B25  | Front Seat Outer Belt (RH)    | 90980-12253 |
| A5   | Pressure SW                  | 90980-10943 | B26  | Door Courtesy SW (Front RH)   | 90980-12470 |
| A6   | Clearance Lamp (Front RH)    | 90980-11156 | B27  | Cooling Fan ECU No.1          | 90980-10841 |
| [A]  | Headla [B] (H)               | 909 [C] 314 | B28  | Cooling Fan ECU No.2          |             |
| A8   | Headlamp Leveling Motor (RH) | 90980-11016 | B29  | Water Temp. Sensor (Radiator) | 90980-10735 |
| A9   | Brake Vacuum Warning SW      | 90980-11252 | B30  | Fuel Filter Warning SW        | 90980-11003 |
| A10  | Brake Fluid Level Warning SW | 90980-11207 | B32  | Door Control Relay (LH)       | 90980-10789 |
| A11  | Windshield Washer Motor      | 90980-11599 | B33  | Step Lamp (LH)                | 90980-10121 |
| A12  | Airbag Sensor (Front RH)     | 90980-11856 | B34  | Junction Connector            |             |
| A13  | Airbag Sensor (Front LH)     | 90980-12490 | B35  | Junction Connector            | 90980-11398 |

[A] : Part Code

[B] : Part Name

[C] : Part Number  
Toyota Part Number are indicated.

Not all of the above part numbers of the connector are established for the supply.

# C TROUBLESHOOTING

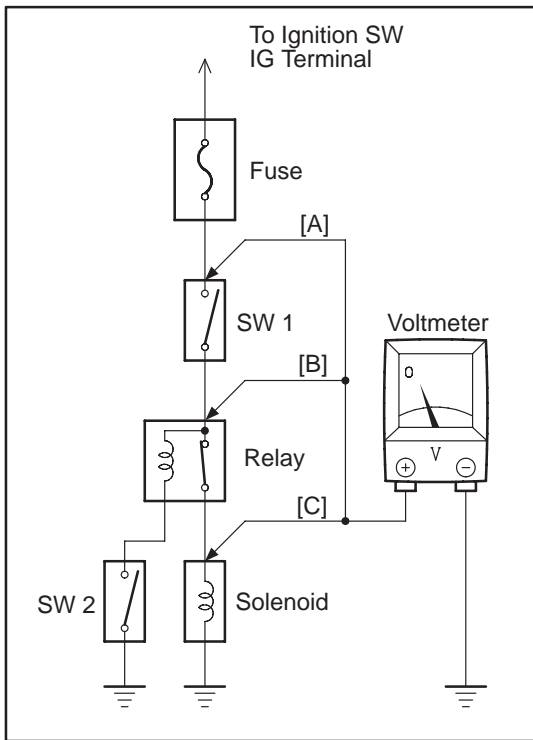

## VOLTAGE CHECK

- (a) Establish conditions in which voltage is present at the check point.

Example:

- [A] – Ignition SW on
- [B] – Ignition SW and SW 1 on
- [C] – Ignition SW, SW 1 and Relay on (SW 2 off)

- (b) Using a voltmeter, connect the negative lead to a good ground point or negative battery terminal, and the positive lead to the connector or component terminal. This check can be done with a test light instead of a voltmeter.

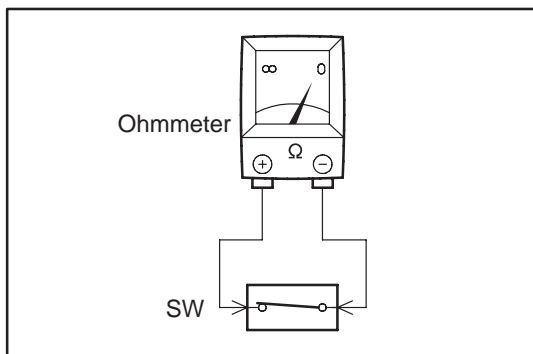

## CONTINUITY AND RESISTANCE CHECK

- (a) Disconnect the battery terminal or wire so there is no voltage between the check points.
- (b) Contact the two leads of an ohmmeter to each of the check points.

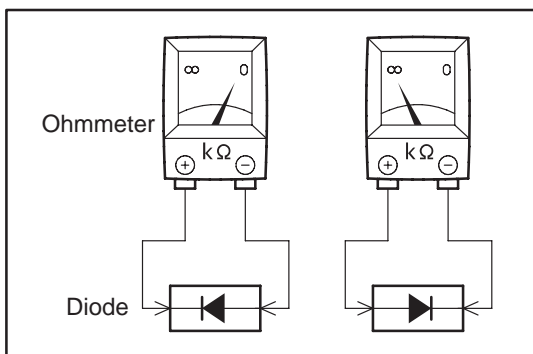

If the circuit has diodes, reverse the two leads and check again.

When contacting the negative lead to the diode positive side and the positive lead to the negative side, there should be continuity.

When contacting the two leads in reverse, there should be no continuity.

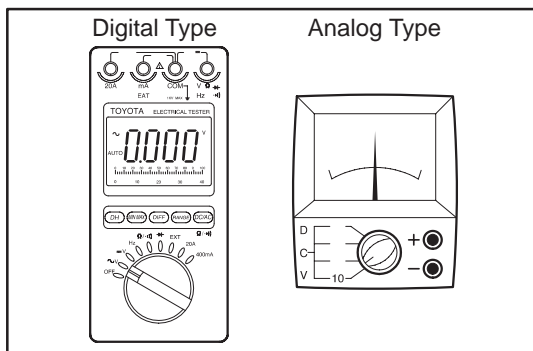

- (c) Use a volt/ohmmeter with high impedance (10 k $\Omega$ /V minimum) for troubleshooting of the electrical circuit.

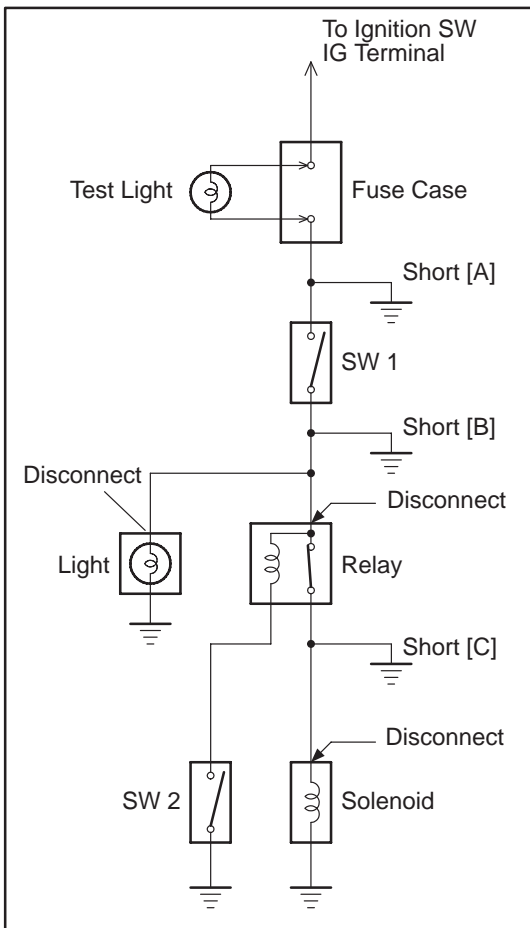

## FINDING A SHORT CIRCUIT

- Remove the blown fuse and disconnect all loads of the fuse.
- Connect a test light in place of the fuse.
- Establish conditions in which the test light comes on.

Example:

- [A] – Ignition SW on
- [B] – Ignition SW and SW 1 on
- [C] – Ignition SW, SW 1 and Relay on (Connect the Relay) and SW 2 off (or Disconnect SW 2)

- Disconnect and reconnect the connectors while watching the test light. The short lies between the connector where the test light stays lit and the connector where the light goes out.
- Find the exact location of the short by lightly shaking the problem wire along the body.

## CAUTION:

- Do not open the cover or the case of the ECU unless absolutely necessary. (If the IC terminals are touched, the IC may be destroyed by static electricity.)
- When replacing the internal mechanism (ECU part) of the digital meter, be careful that no part of your body or clothing comes in contact with the terminals of leads from the IC, etc. of the replacement part (spare part).

## DISCONNECTION OF MALE AND FEMALE CONNECTORS

To pull apart the connectors, pull on the connector itself, not the wire harness.

HINT: Check to see what kind of connector you are disconnecting before pulling apart.

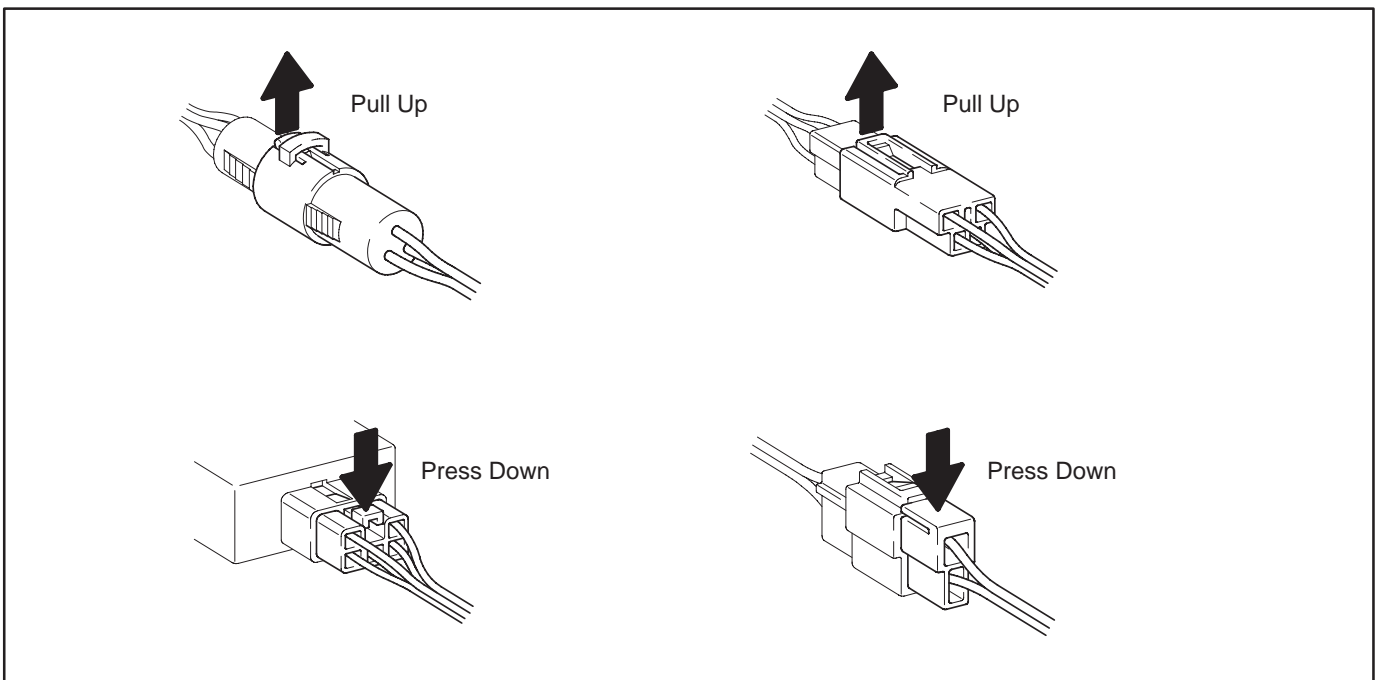

# C TROUBLESHOOTING

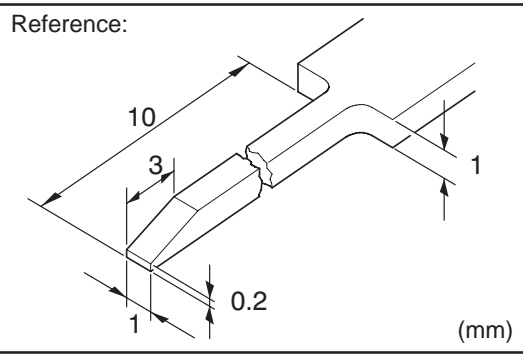

## HOW TO REPLACE TERMINAL (with terminal retainer or secondary locking device)

### 1. PREPARE THE SPECIAL TOOL

HINT : To remove the terminal from the connector, please construct and use the special tool or like object shown on the left.

### 2. DISCONNECT CONNECTOR

### 3. DISENGAGE THE SECONDARY LOCKING DEVICE OR TERMINAL RETAINER.

(a) Locking device must be disengaged before the terminal locking clip can be released and the terminal removed from the connector.

(b) Use a special tool or the terminal pick to unlock the secondary locking device or terminal retainer.

#### NOTICE:

**Do not remove the terminal retainer from connector body.**

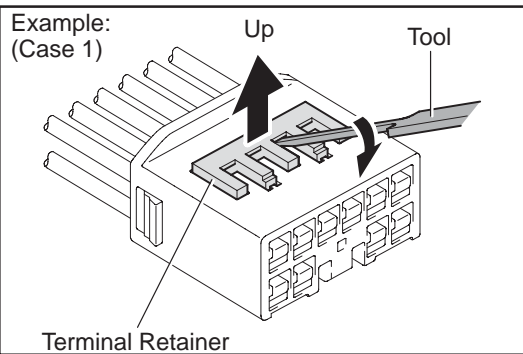

#### [A] For Non-Waterproof Type Connector

HINT : The needle insertion position varies according to the connector's shape (number of terminals etc.), so check the position before inserting it.

#### "Case 1"

Raise the terminal retainer up to the temporary lock position.

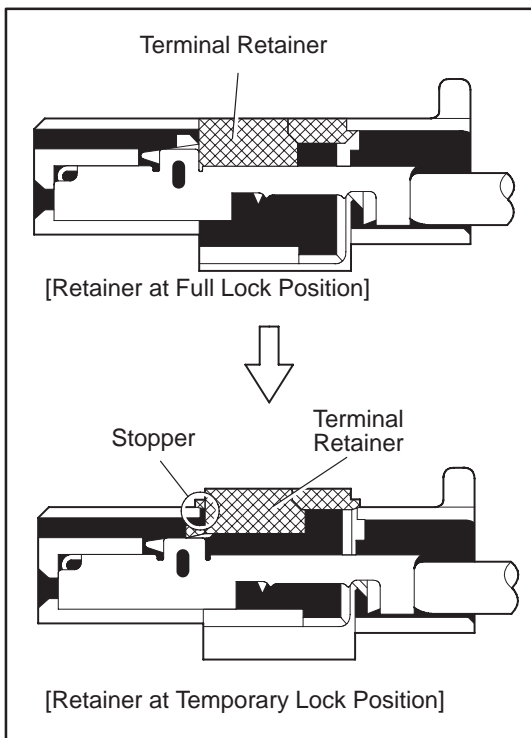

#### "Case 2"

Open the secondary locking device.

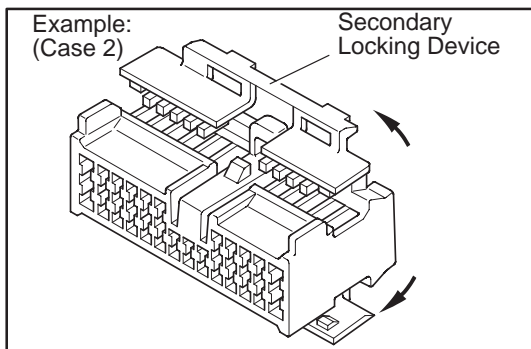

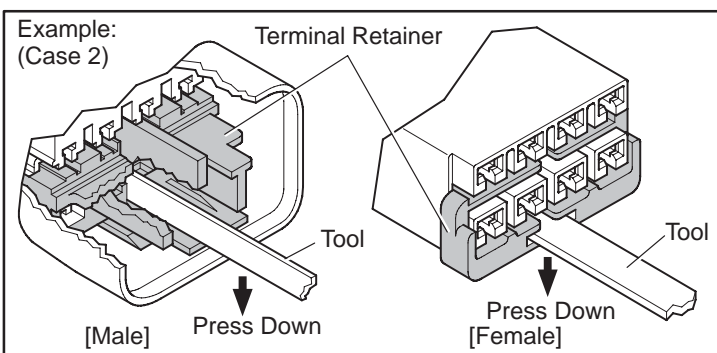
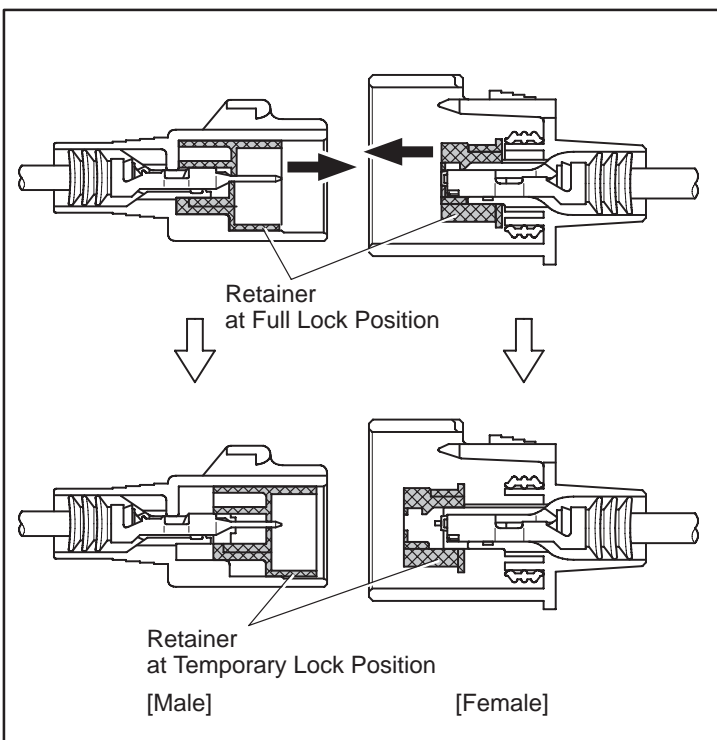
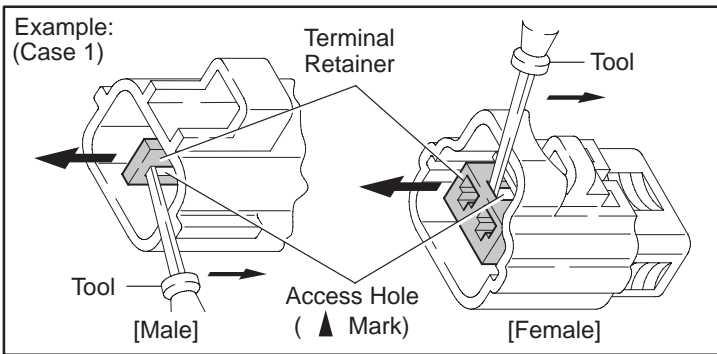
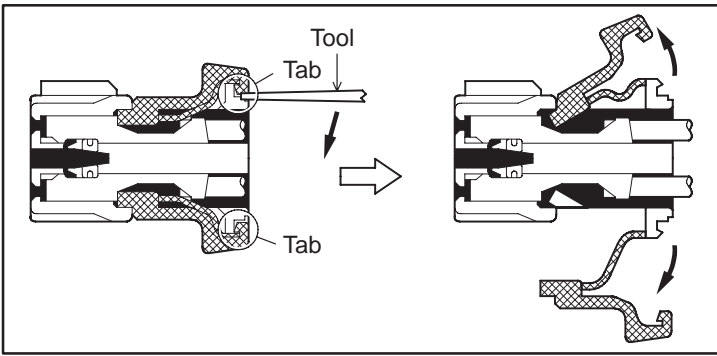

[B] For Waterproof Type Connector

HINT : Terminal retainer color is different according to connector body.

Example:

| Terminal Retainer | Connector Body |
|-------------------|----------------|
| Black or White    | Gray           |
| Black or White    | Dark Gray      |
| Gray or White     | Black          |

"Case 1"

Type where terminal retainer is pulled up to the temporary lock position (Pull Type).

Insert the special tool into the terminal retainer access hole (▲Mark) and pull the terminal retainer up to the temporary lock position.

HINT : The needle insertion position varies according to the connector's shape (Number of terminals etc.), so check the position before inserting it.

"Case 2"

Type which cannot be pulled as far as Power Lock insert the tool straight into the access hole of terminal retainer as shown.



## C TROUBLESHOOTING

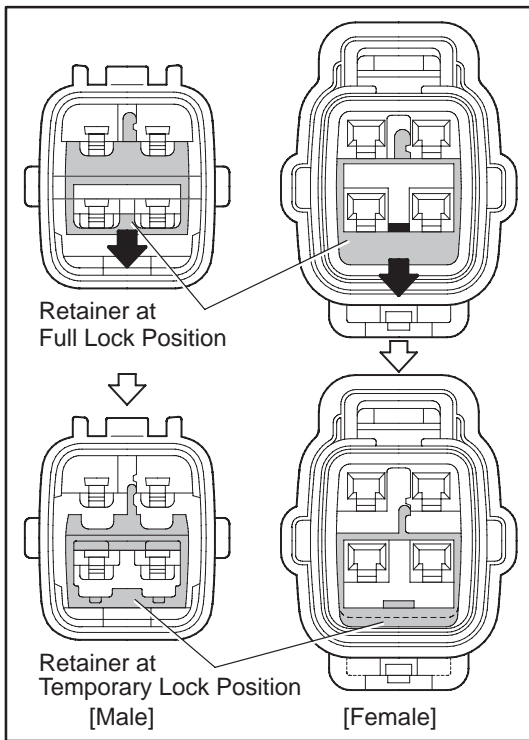

Push the terminal retainer down to the temporary lock position.

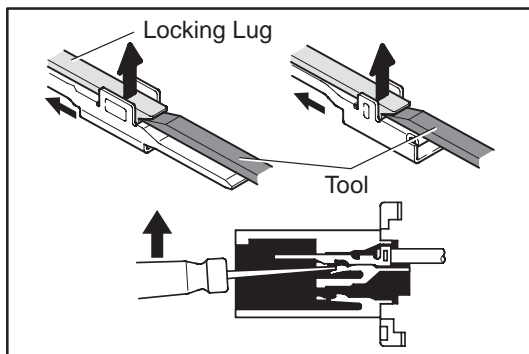

(c) Release the locking lug from terminal and pull the terminal out from rear.

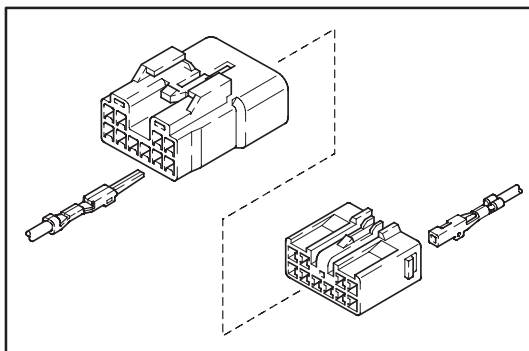

### 4. INSTALL TERMINAL TO CONNECTOR

(a) Insert the terminal.

HINT:

1. Make sure the terminal is positioned correctly.
2. Insert the terminal until the locking lug locks firmly.
3. Insert the terminal with terminal retainer in the temporary lock position.

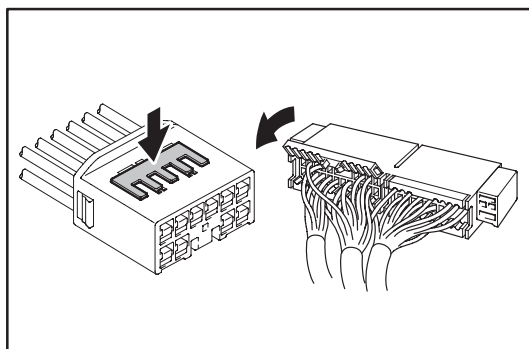

(b) Push the secondary locking device or terminal retainer in to the full lock position.

### 5. CONNECT CONNECTOR











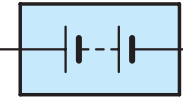

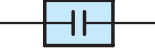





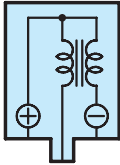

**ABBREVIATIONS**





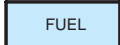

The following abbreviations are used in this manual.

|        |   |  |
|--------|---|--|
| A/C    | = | Air Conditioning                               |
| A/T    | = | Automatic Transaxle                            |
| ABS    | = | Anti-Lock Brake System                         |
| ACIS   | = | Acoustic Control Induction System              |
| ACM    | = | Active Control Engine Mount                    |
| CAN    | = | Controller Area Network                        |
| EC     | = | Electrochromic                                 |
| ECU    | = | Electronic Control Unit                        |
| ESA    | = | Electronic Spark Advance                       |
| ETCS-i | = | Electronic Throttle Control System-intelligent |
| FL     | = | Fusible Link                                   |
| IC     | = | Integrated Circuit                             |
| J/B    | = | Junction Block                                 |
| LCD    | = | Liquid Crystal Display                         |
| LH     | = | Left-Hand                                      |
| M/T    | = | Manual Transaxle                               |
| R/B    | = | Relay Block                                    |
| RH     | = | Right-Hand                                     |
| SFI    | = | Sequential Multiport Fuel Injection            |
| SRS    | = | Supplemental Restraint System                  |
| SW     | = | Switch   |
| TEMP.  | = | Temperature                                    |
| TRAC   | = | Traction Control                               |
| VSC    | = | Vehicle Stability Control                      |
| VSV    | = | Vacuum Switching Valve                         |
| VVT    | = | Variable Valve Timing                          |
| VVT-i  | = | Variable Valve Timing-intelligent              |
| w/     | = | With   |
| w/o    | = | Without  |

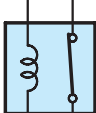
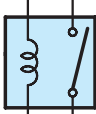
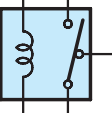
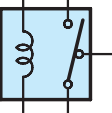
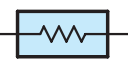
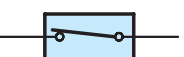
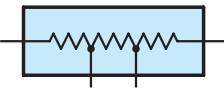
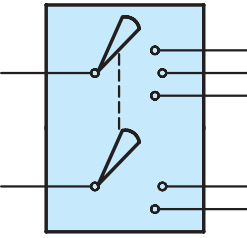
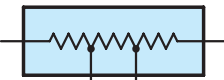
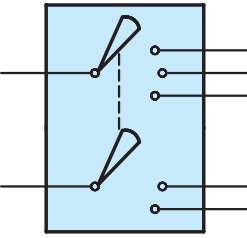
\* The titles given inside the components are the names of the terminals (terminal codes) and are not treated as being abbreviations.

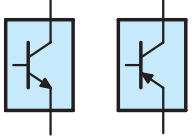
# E GLOSSARY OF TERMS AND SYMBOLS

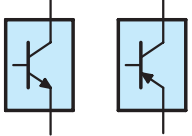
|  |   |
|--|---|
|  <p><b>BATTERY</b><br/>Stores chemical energy and converts it into electrical energy. Provides DC current for the auto's various electrical circuits.</p>   |  <p><b>GROUND</b><br/>The point at which wiring attaches to the Body, thereby providing a return path for an electrical circuit; without a ground, current cannot flow.</p>  |
|  <p><b>CAPACITOR (Condenser)</b><br/>A small holding unit for temporary storage of electrical voltage.</p>  | <p><b>HEADLIGHTS</b><br/>Current flow causes a headlight filament to heat up and emit light. A headlight may have either a single (1) filament or a double (2) filament</p> <p><b>1. SINGLE FILAMENT</b><br/></p> <p><b>2. DOUBLE FILAMENT</b><br/></p> |
|  <p><b>CIGARETTE LIGHTER</b><br/>An electric resistance heating element.</p>  |   |
|  <p><b>CIRCUIT BREAKER</b><br/>Basically a reusable fuse, a circuit breaker will heat and open if too much current flows through it. Some units automatically reset when cool, others must be manually reset.</p>   |  <p><b>HORN</b><br/>An electric device which sounds a loud audible signal.</p>   |
|  <p><b>DIODE</b><br/>A semiconductor which allows current flow in only one direction.</p>  |  <p><b>IGNITION COIL</b><br/>Converts low-voltage DC current into high-voltage ignition current for firing the spark plugs.</p>   |
|  <p><b>DIODE, ZENER</b><br/>A diode which allows current flow in one direction but blocks reverse flow only up to a specific voltage. Above that potential, it passes the excess voltage. This acts as a simple voltage regulator.</p>  |  <p><b>LIGHT</b><br/>Current flow through a filament causes the filament to heat up and emit light.</p>   |
|  <p><b>PHOTODIODE</b><br/>The photodiode is a semiconductor which controls the current flow according to the amount of light.</p>   |  <p><b>LED (LIGHT EMITTING DIODE)</b><br/>Upon current flow, these diodes emit light without producing the heat of a comparable light.</p>  |
|  <p><b>DISTRIBUTOR, IIA</b><br/>Channels high-voltage current from the ignition coil to the individual spark plugs.</p>   |  <p><b>METER, ANALOG</b><br/>Current flow activates a magnetic coil which causes a needle to move, thereby providing a relative display against a background calibration.</p>  |
|  <p><b>FUSE</b><br/>A thin metal strip which burns through when too much current flows through it, thereby stopping current flow and protecting a circuit from damage.</p>  <p><b>FUSIBLE LINK</b><br/>(for Medium Current Fuse) A heavy-gauge wire placed in high amperage circuits which burns through on overloads, thereby protecting the circuit. The numbers indicate the crosssection surface area of the wires.</p>  <p>(for High Current Fuse or Fusible Link)</p> |  <p><b>METER, DIGITAL</b><br/>Current flow activates one or many LED's, LCD's, or fluorescent displays, which provide a relative or digital display.</p>   |
|  |  <p><b>MOTOR</b><br/>A power unit which converts electrical energy into mechanical energy, especially rotary motion.</p>   |

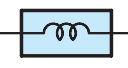
|  |   |
|--|---|
|  <p><b>RELAY</b><br/>Basically, an electrically operated switch which may be normally closed (1) or open (2). Current flow through a small coil creates a magnetic field which either opens or closes an attached switch.</p> <p><b>1. NORMALLY CLOSED</b></p> <p><b>2. NORMALLY OPEN</b></p> |  <p><b>SPEAKER</b><br/>An electromechanical device which creates sound waves from current flow.</p>  |
|  <p><b>RELAY, DOUBLE THROW</b><br/>A relay which passes current through one set of contacts or the other.</p>   | <p><b>SWITCH, MANUAL</b><br/>Opens and closes circuits, thereby stopping (1) or allowing (2) current flow.</p>  <p><b>1. NORMALLY OPEN</b></p> <p><b>2. NORMALLY CLOSED</b></p>  |
|  <p><b>RESISTOR</b><br/>An electrical component with a fixed resistance, placed in a circuit to reduce voltage to a specific value.</p>   | <p><b>SWITCH, DOUBLE THROW</b><br/>A switch which continuously passes current through one set of contacts or the other.</p>   |
|  <p><b>RESISTOR, TAPPED</b><br/>A resistor which supplies two or more different non adjustable resistance values.</p>  | <p><b>SWITCH, IGNITION</b><br/>A key operated switch with several positions which allows various circuits, particularly the primary ignition circuit, to become operational.</p>   |
|  <p><b>RESISTOR, VARIABLE or RHEOSTAT</b><br/>A controllable resistor with a variable rate of resistance. Also called a potentiometer or rheostat.</p>  | <p><b>SWITCH, WIPER PARK</b><br/>Automatically returns wipers to the stop position when the wiper switch is turned off.</p>    |
|  <p><b>SENSOR (Thermistor)</b><br/>A resistor which varies its resistance with temperature.</p>   | <p><b>TRANSISTOR</b><br/>A solidstate device typically used as an electronic relay; stops or passes current depending on the voltage applied at "base".</p>   |
|  <p><b>SENSOR, SPEED</b><br/>Uses magnetic impulses to open and close a switch to create a signal for activation of other components.<br/>(Reed Switch Type)</p>  | <p><b>WIRES</b><br/>Wires are always drawn as straight lines on wiring diagrams. Crossed wires (1) without a black dot at the junction are not joined; crossed wires (2) with a black dot or octagonal (○) mark at the junction are spliced (joined) connections.</p>  <p><b>(1) NOT CONNECTED</b></p> <p><b>(2) SPLICED</b></p> |
|  <p><b>SHORT PIN</b><br/>Used to provide an unbroken connection within a junction block.</p>  |   |
|  <p><b>SOLENOID</b><br/>An electromagnetic coil which forms a magnetic field when current flows, to move a plunger, etc.</p>  |   |

# F RELAY LOCATIONS

## [Engine Compartment]

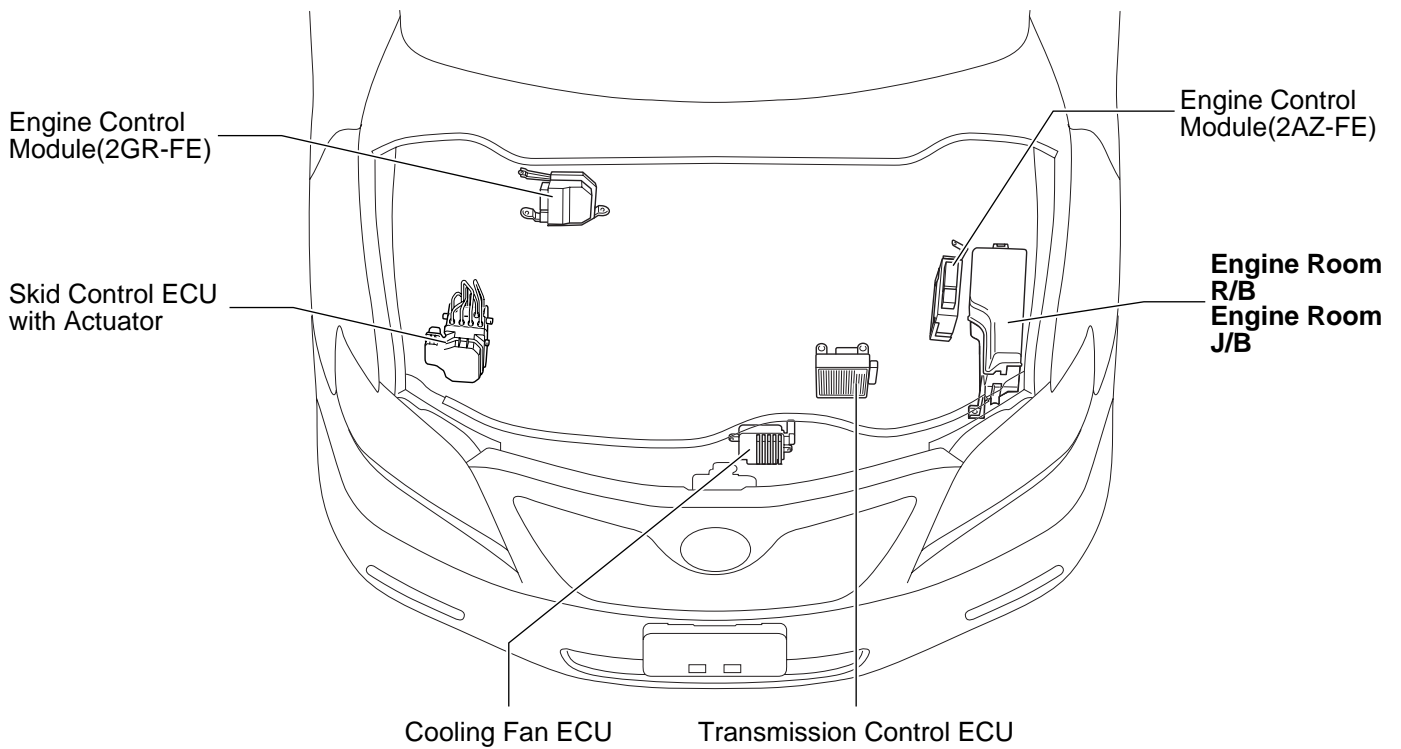

## [Instrument Panel]

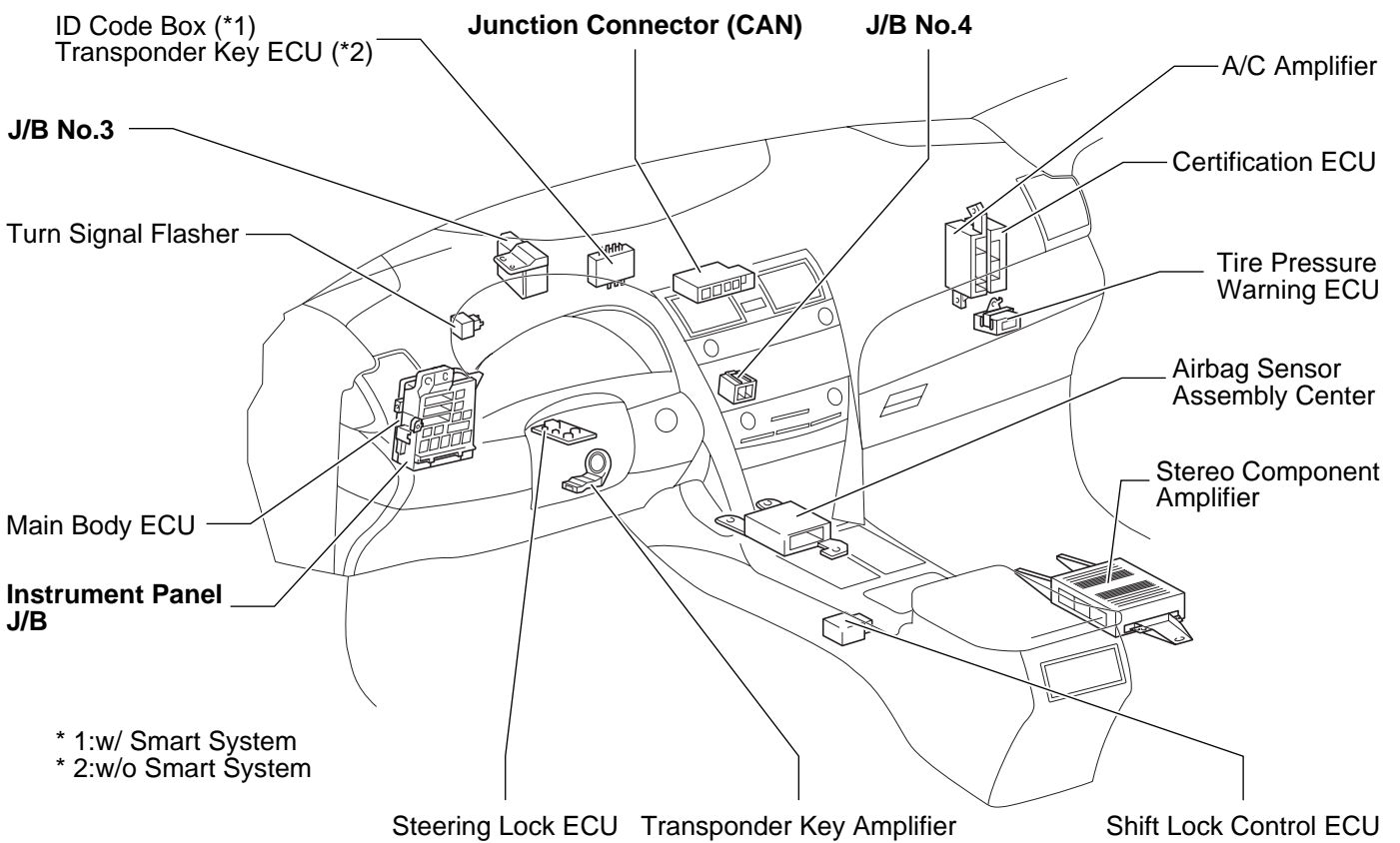

**[Body]**

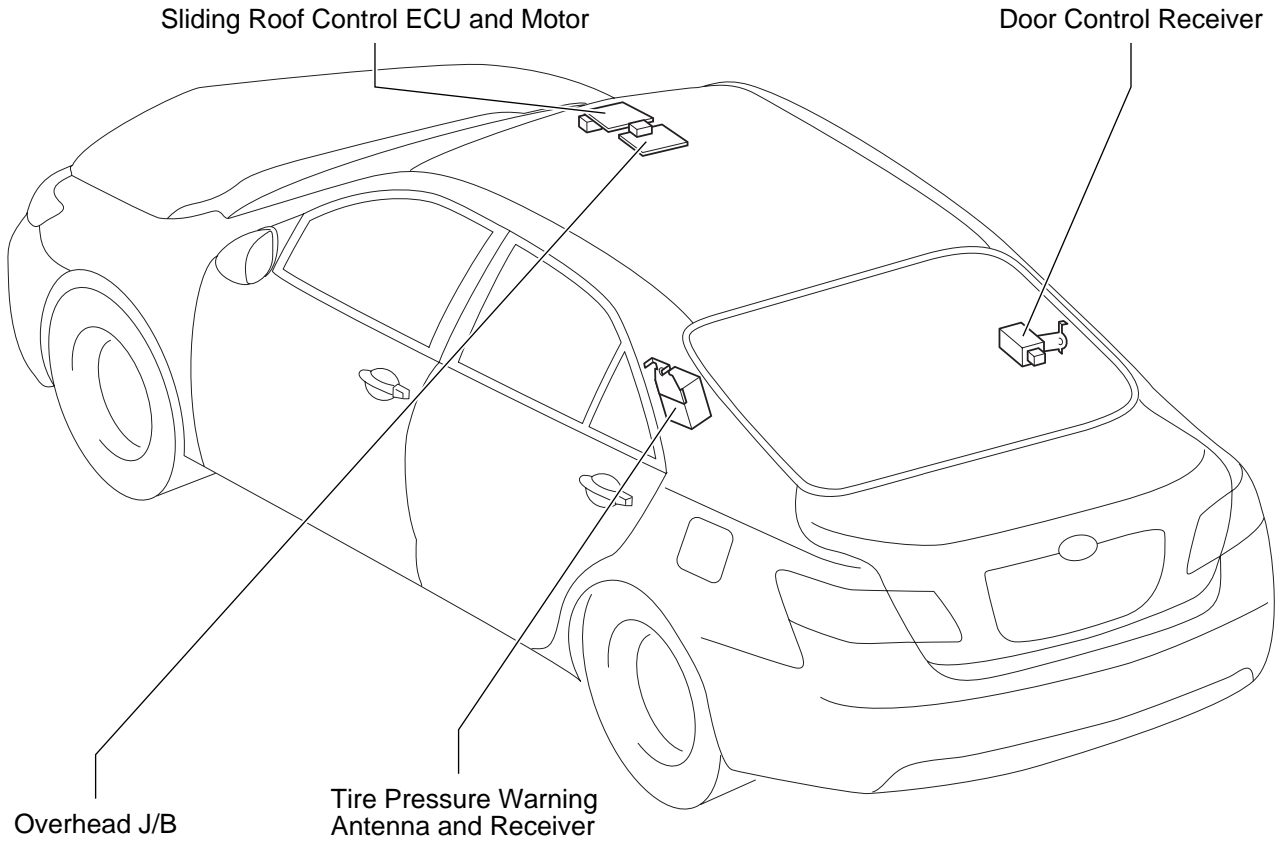

**[Seat]**

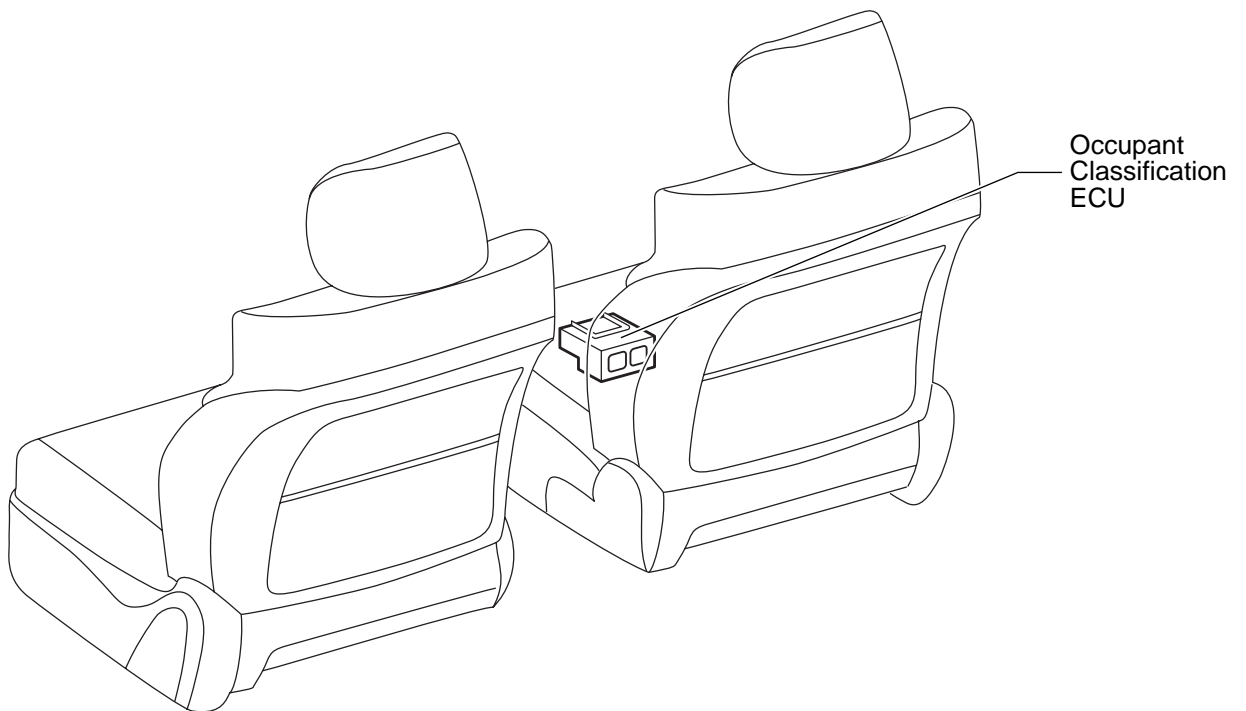

# F RELAY LOCATIONS

|                     |  |
|---------------------|--|
| ① : Engine Room R/B | <b>Engine Compartment Left (See Page 20)</b> |
| ○ : Engine Room J/B |  |

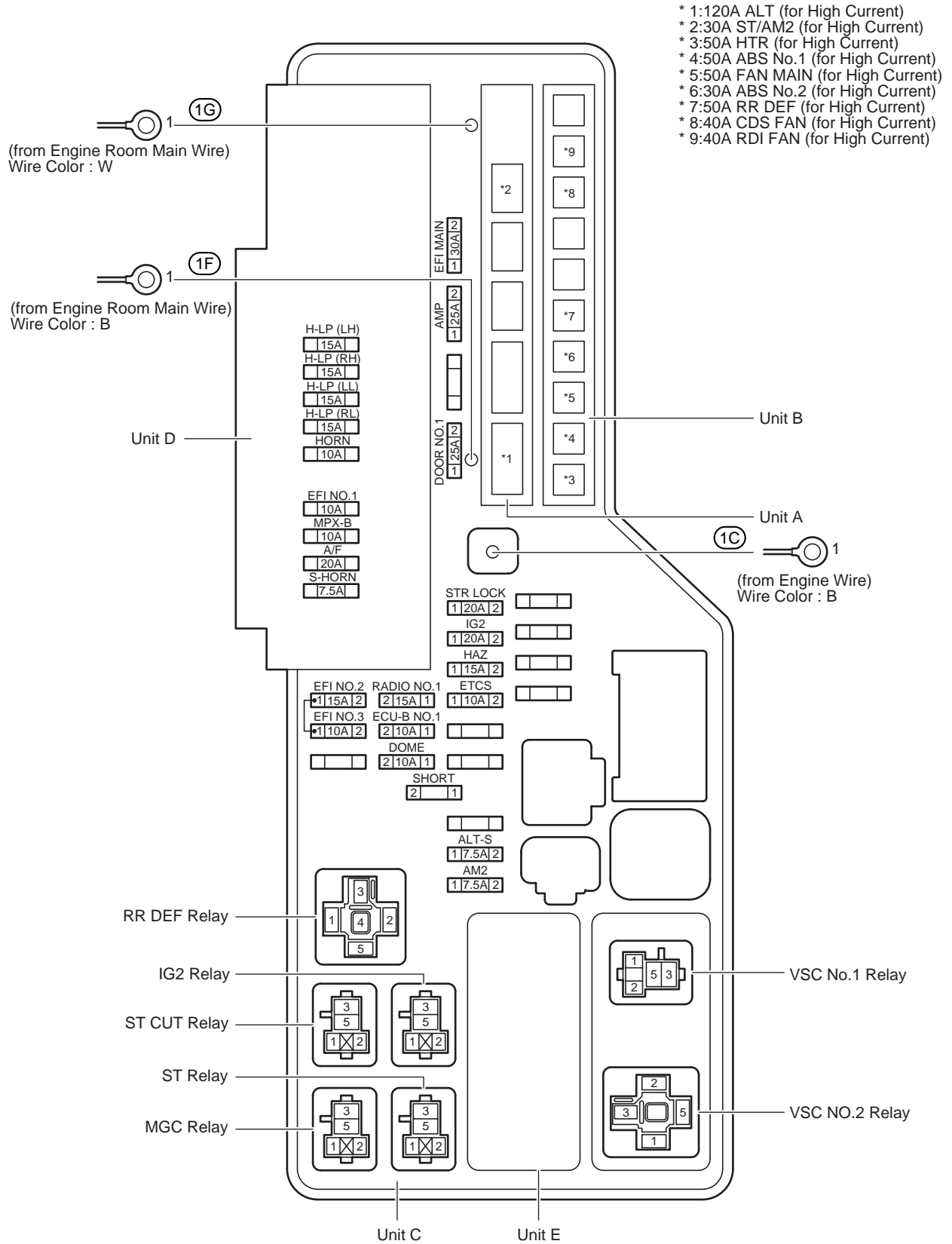

# Unit E

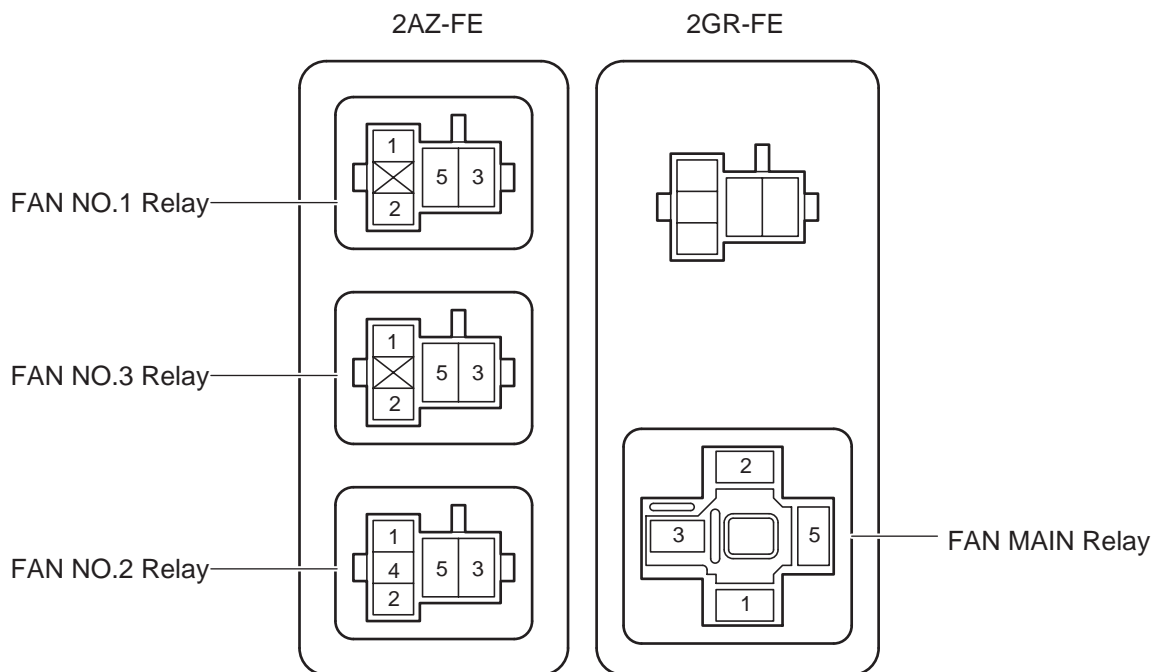



# F RELAY LOCATIONS

|                     |                                       |
|---------------------|---------------------------------------|
| ① : Engine Room R/B | Engine Compartment Left (See Page 20) |
| ○ : Engine Room J/B |                                       |

## Unit D

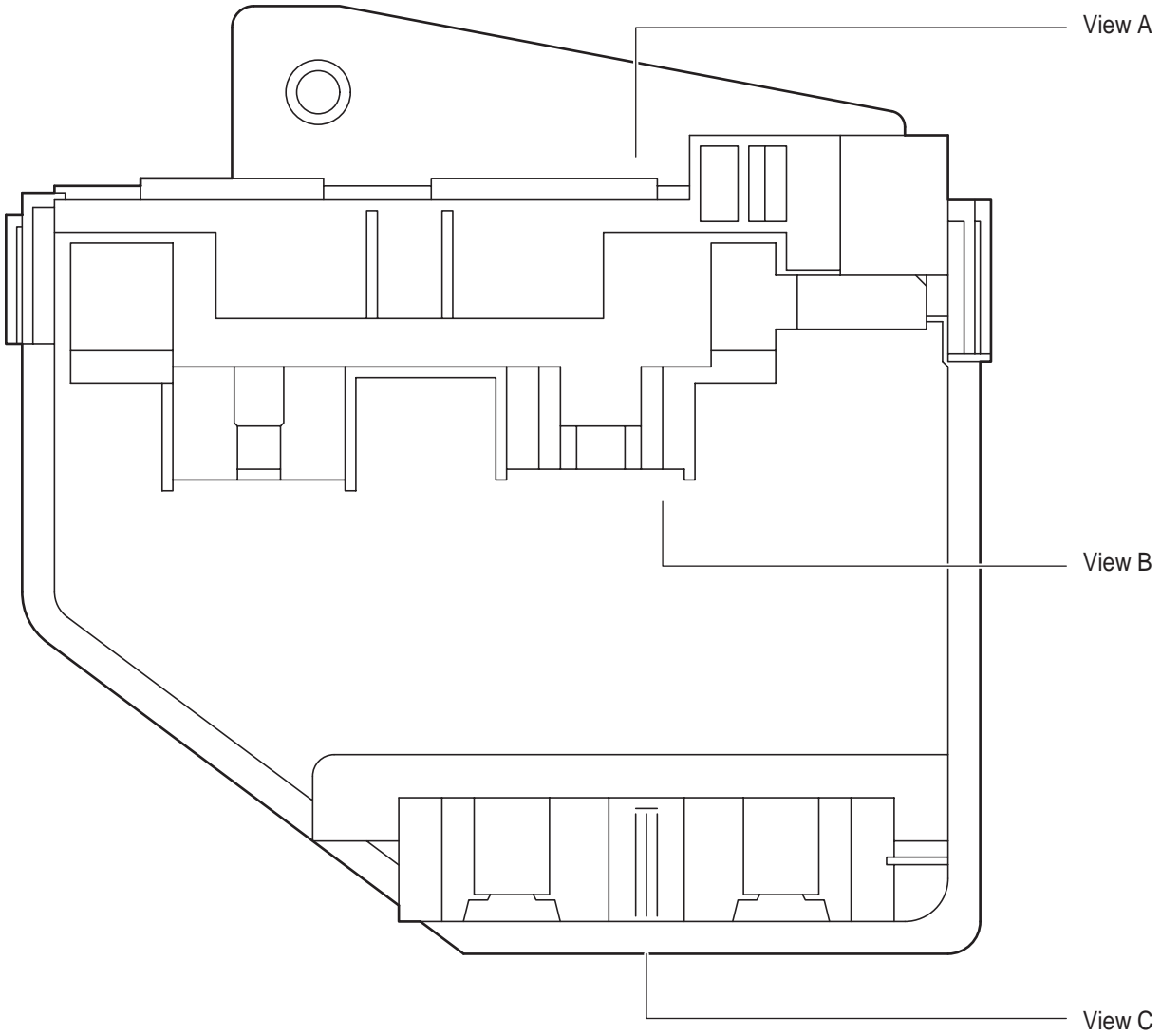

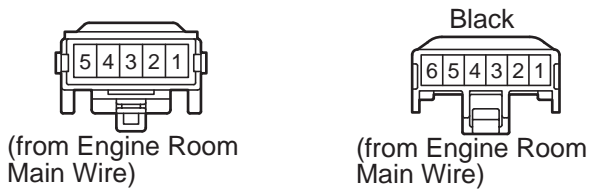
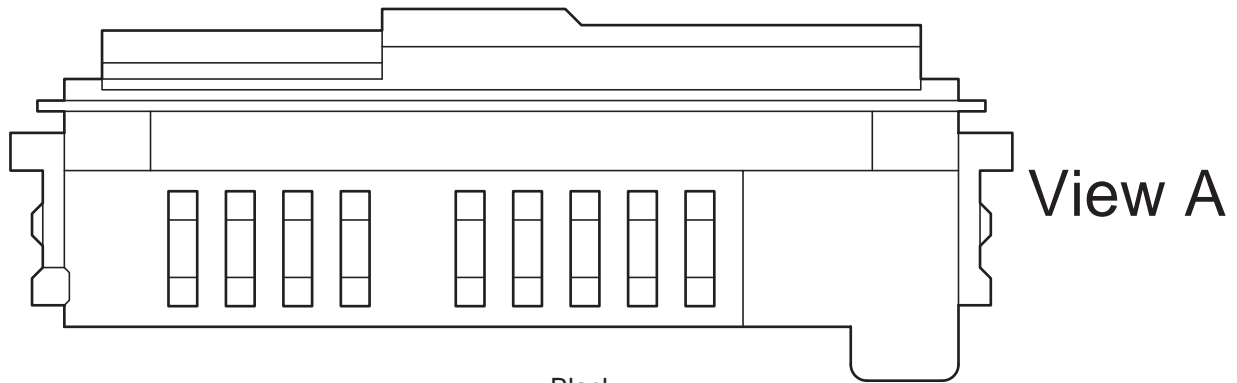

1A

1B

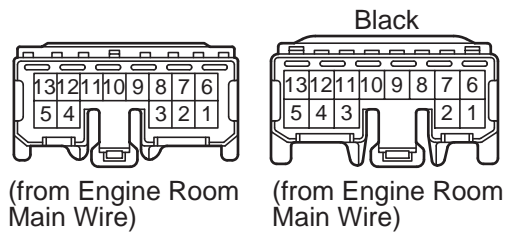
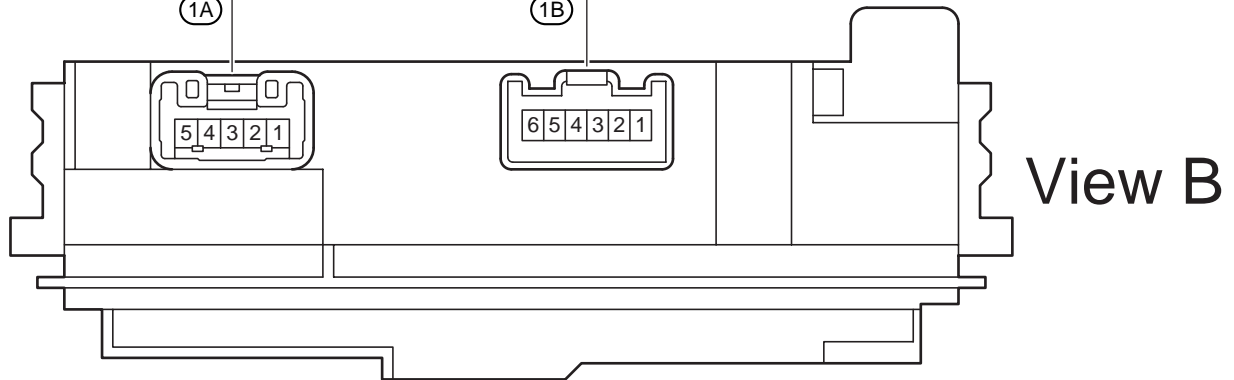

1D

1E

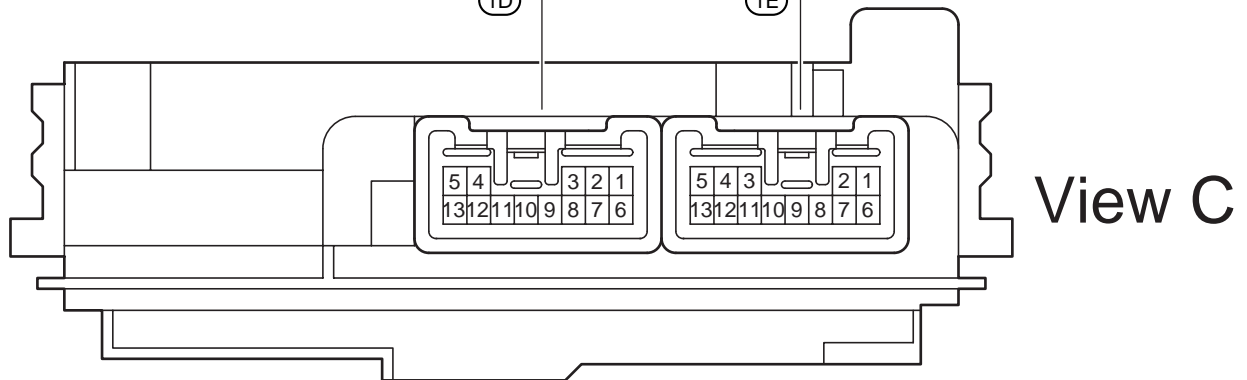



(Cont'd)

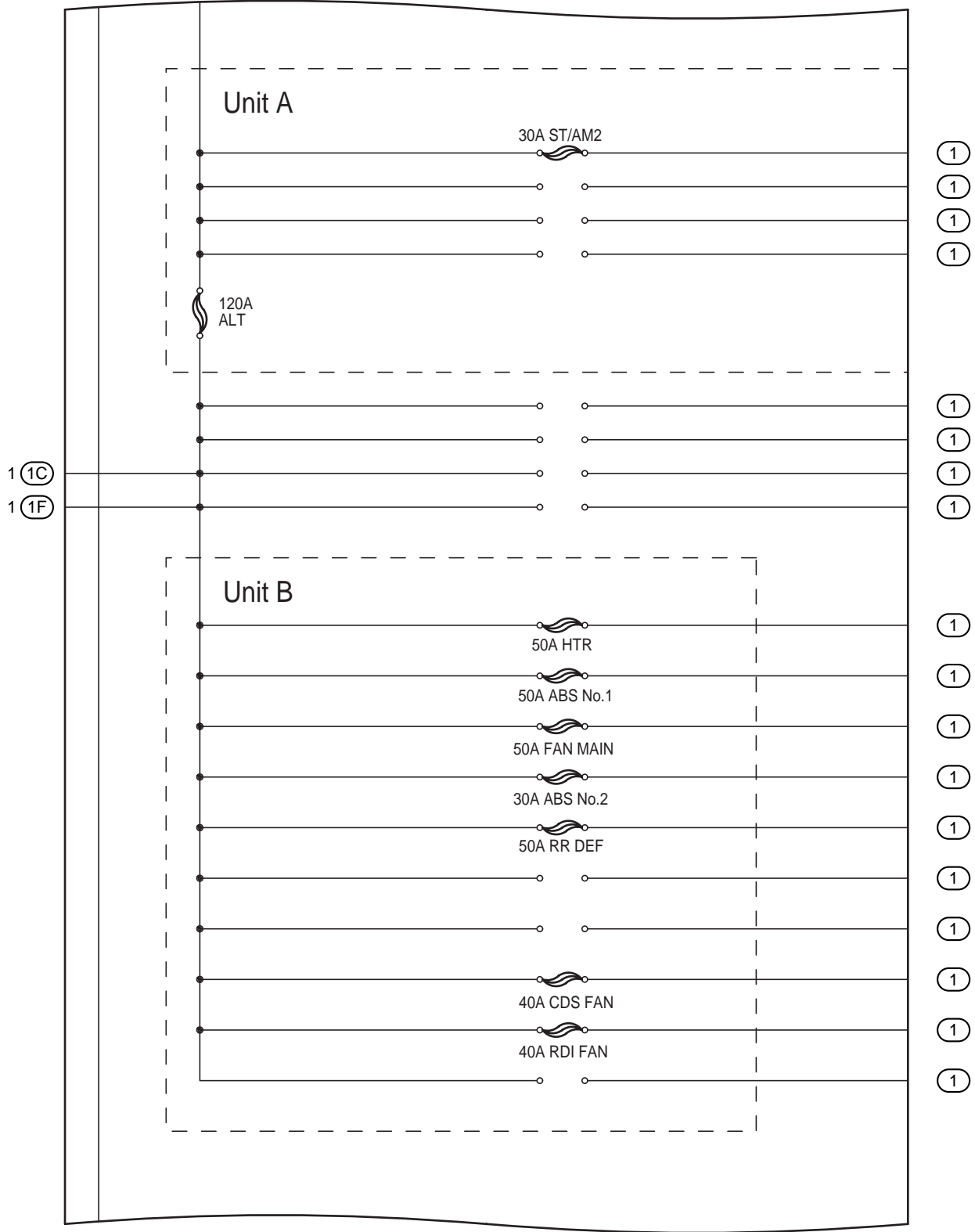

(Cont. Next Page)

# F RELAY LOCATIONS

## [Engine Room R/B and Engine Room J/B Inner Circuit]

(Cont'd)

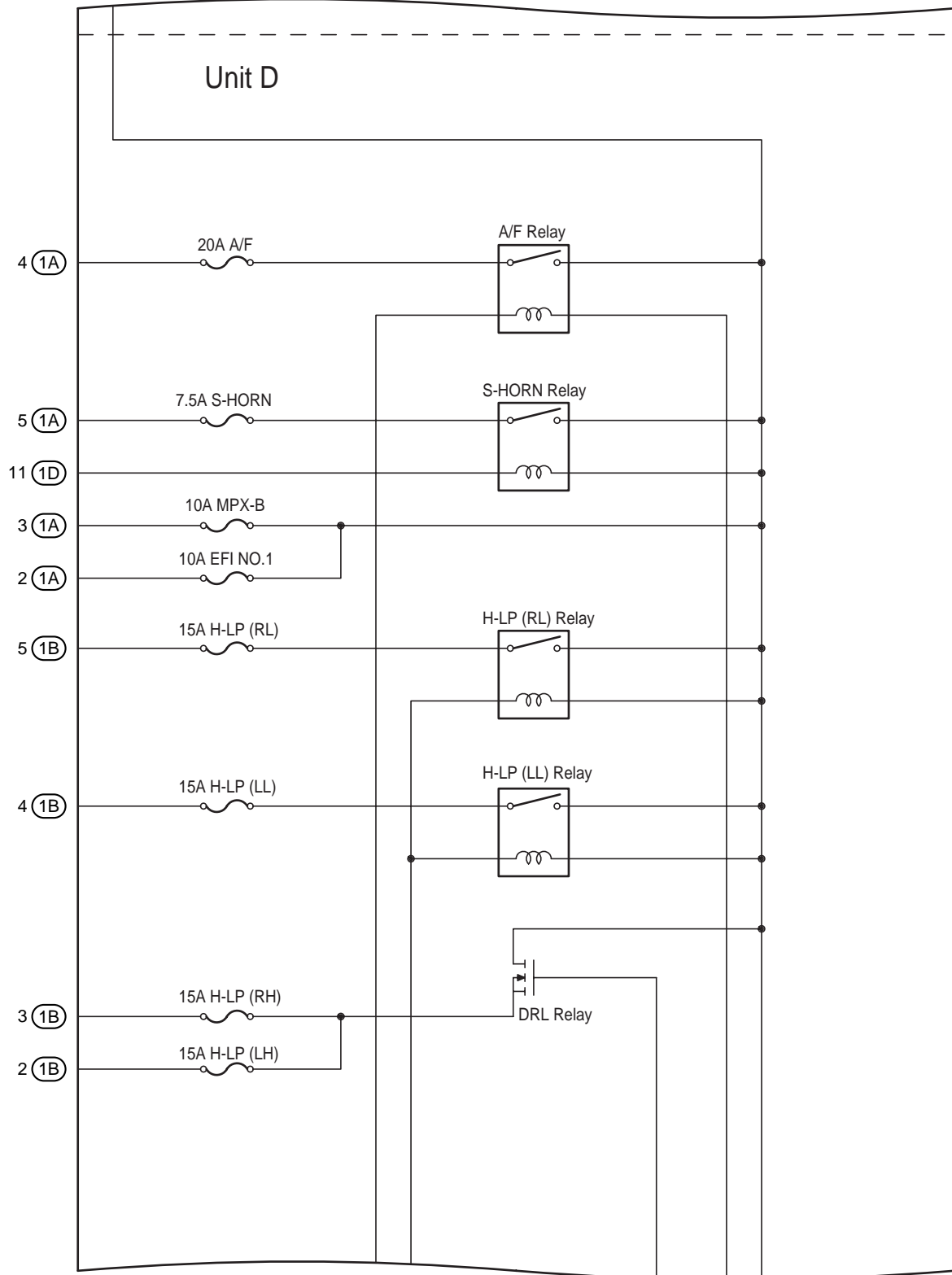

(Cont. Next Page)

(Cont'd)

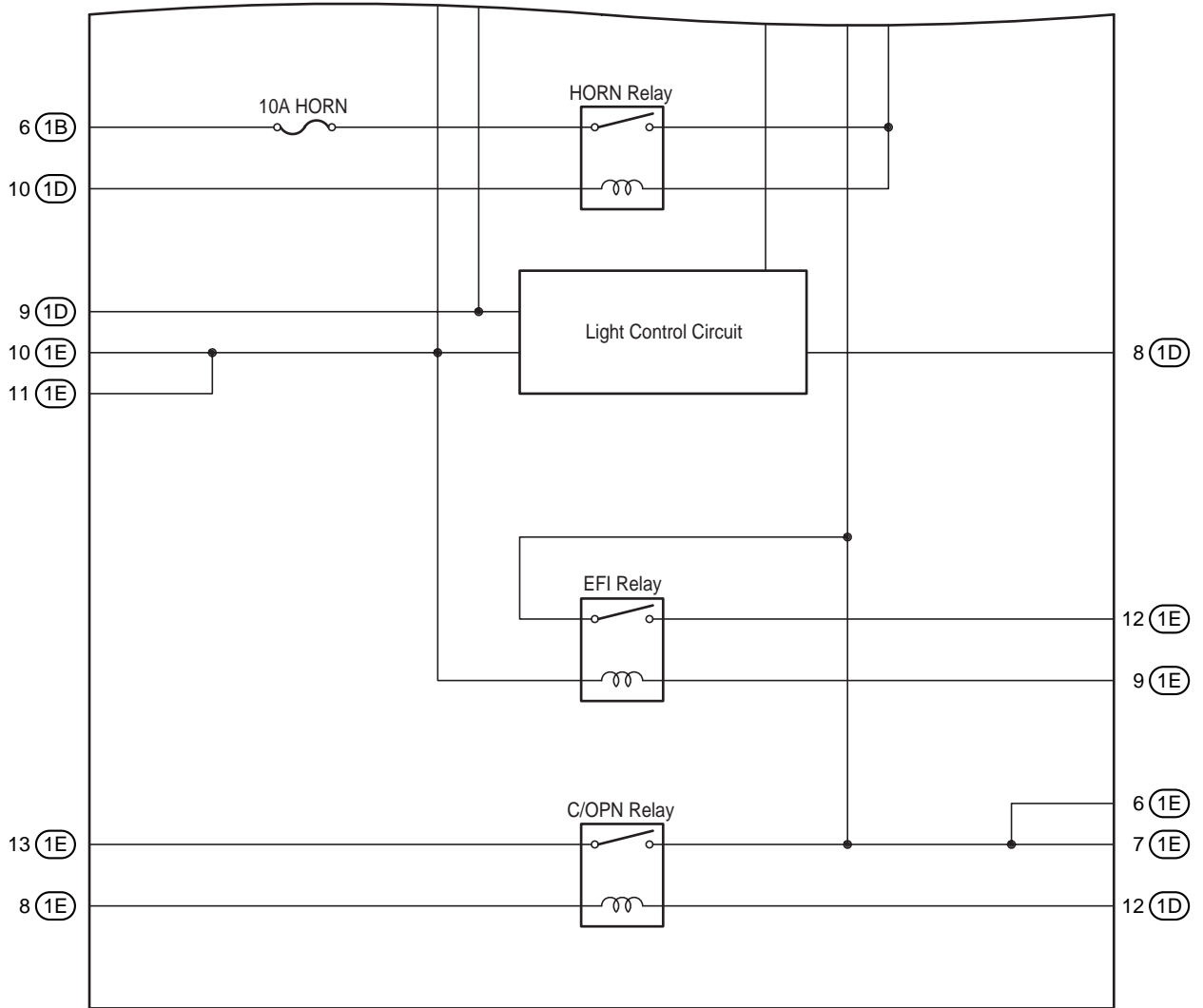

# F RELAY LOCATIONS

○ : Instrument Panel J/B      Cowl Side Left (See Page 20)

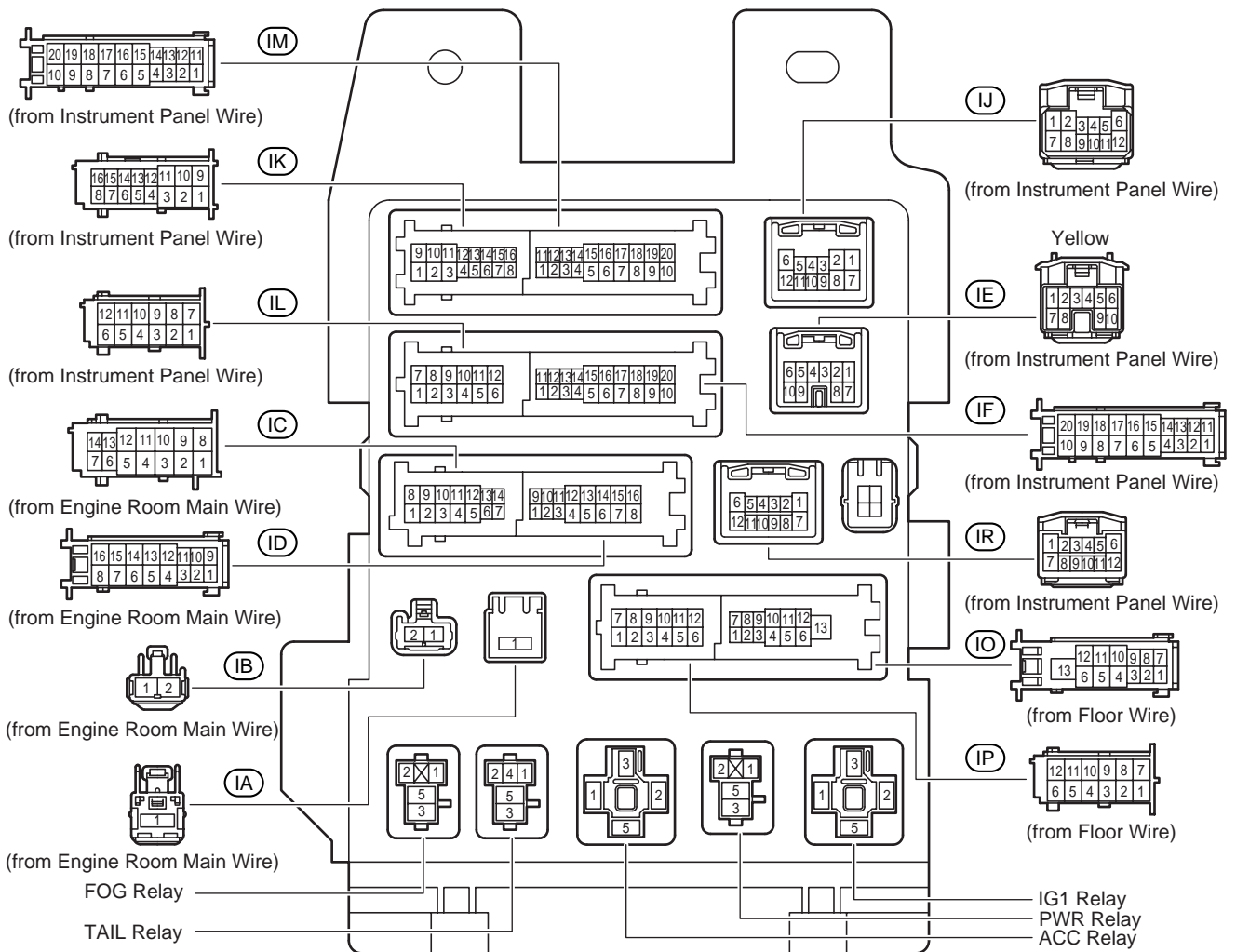

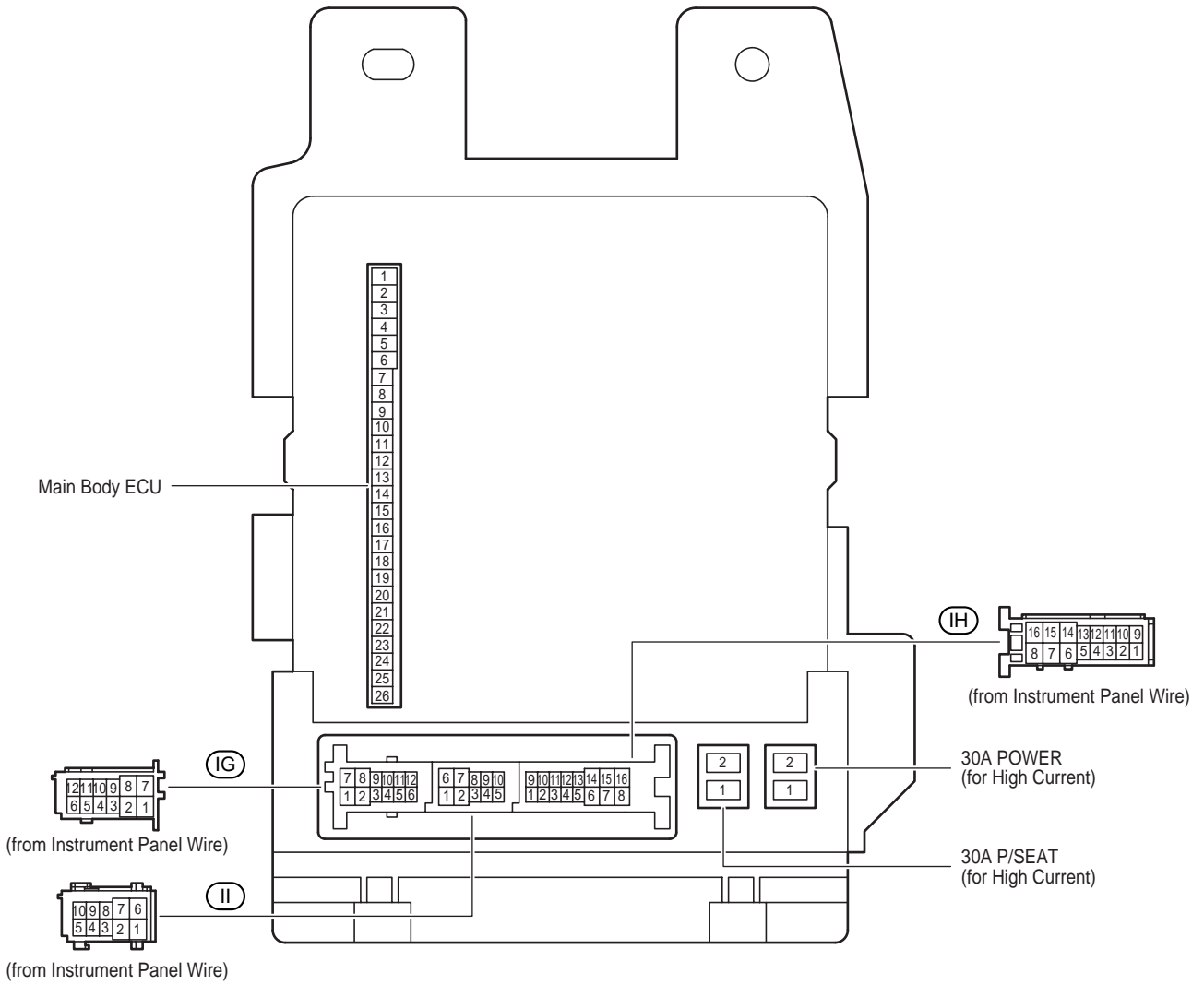



# F RELAY LOCATIONS

○ : Instrument Panel J/B      Cowl Side Left (See Page 20)

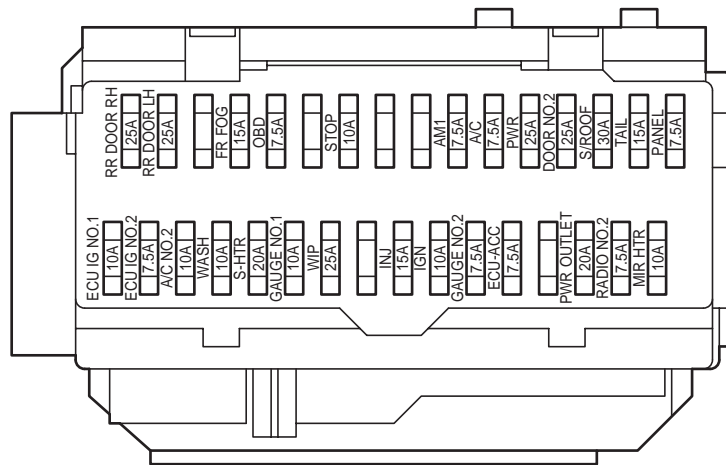

[Instrument Panel J/B Inner Circuit]

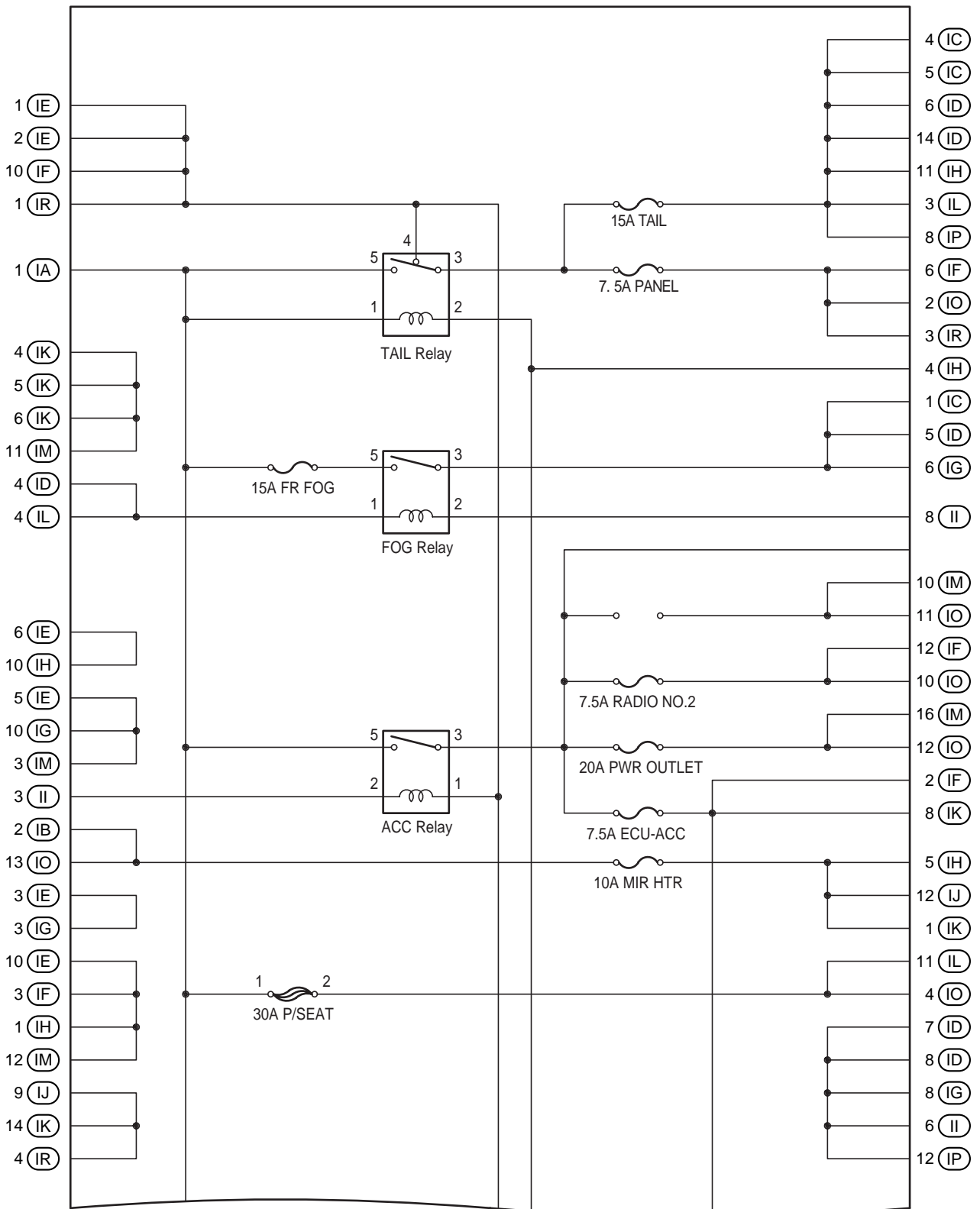

(Cont. Next Page)

# F RELAY LOCATIONS

## [Instrument Panel J/B Inner Circuit]

(Cont'd)

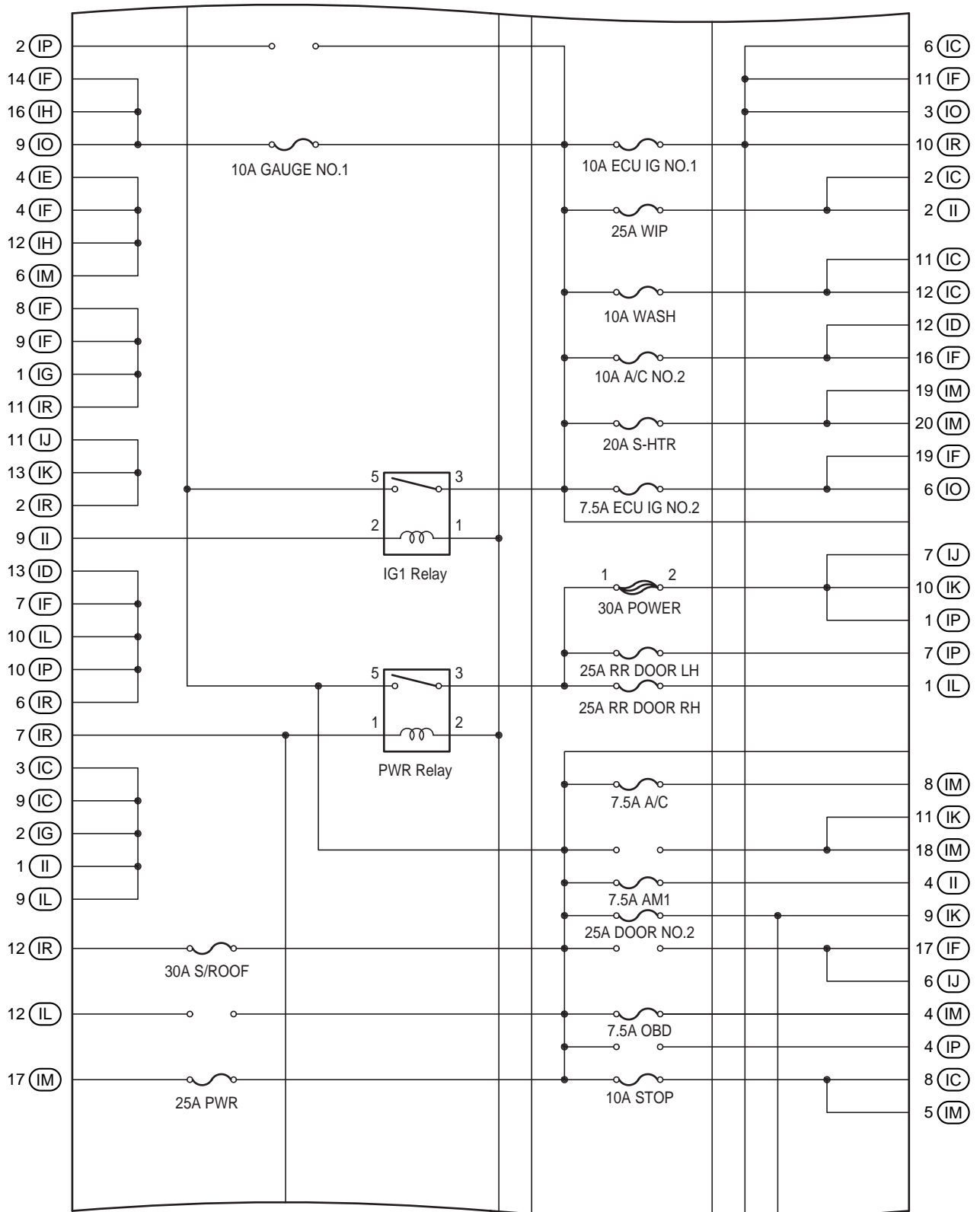

(Cont. Next Page)



# F RELAY LOCATIONS

○ : J/B No.3 Behind the Combination Meter (See Page 20)

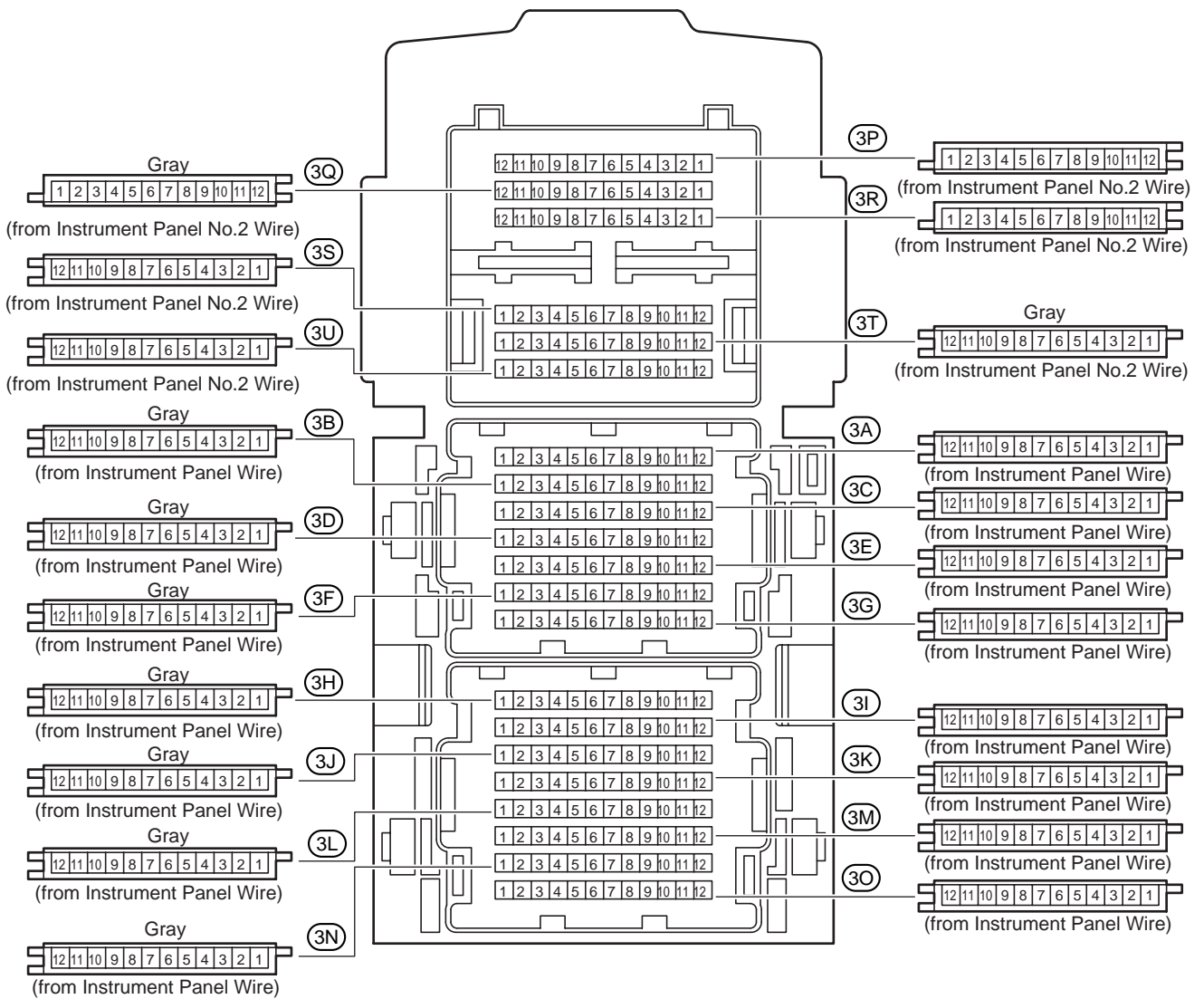



# F RELAY LOCATIONS

## [J/B No.3 Inner Circuit]

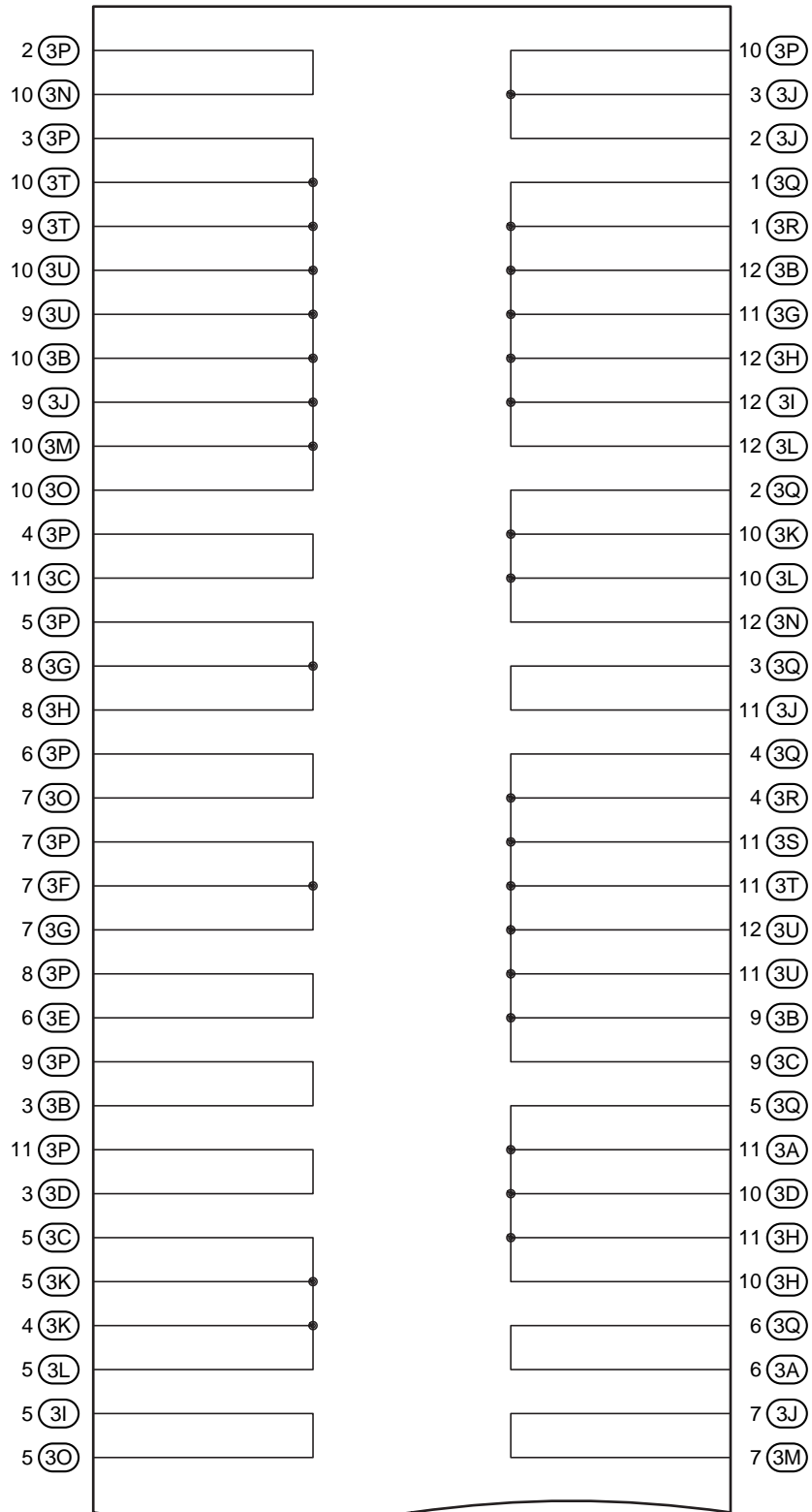

(Cont. Next Page)

(Cont'd)

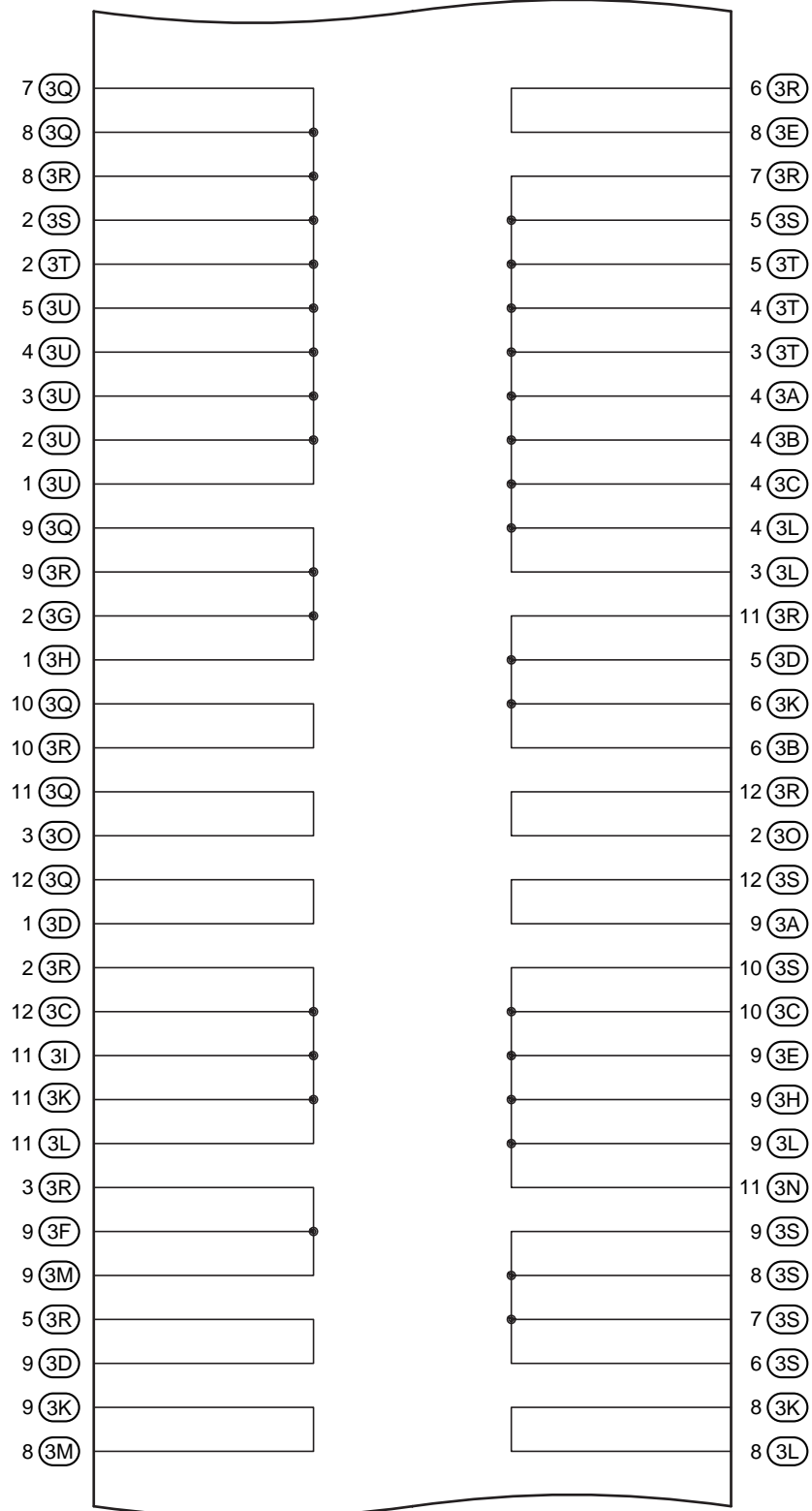

(Cont. Next Page)



# F RELAY LOCATIONS

## [J/B No.3 Inner Circuit]

(Cont'd)

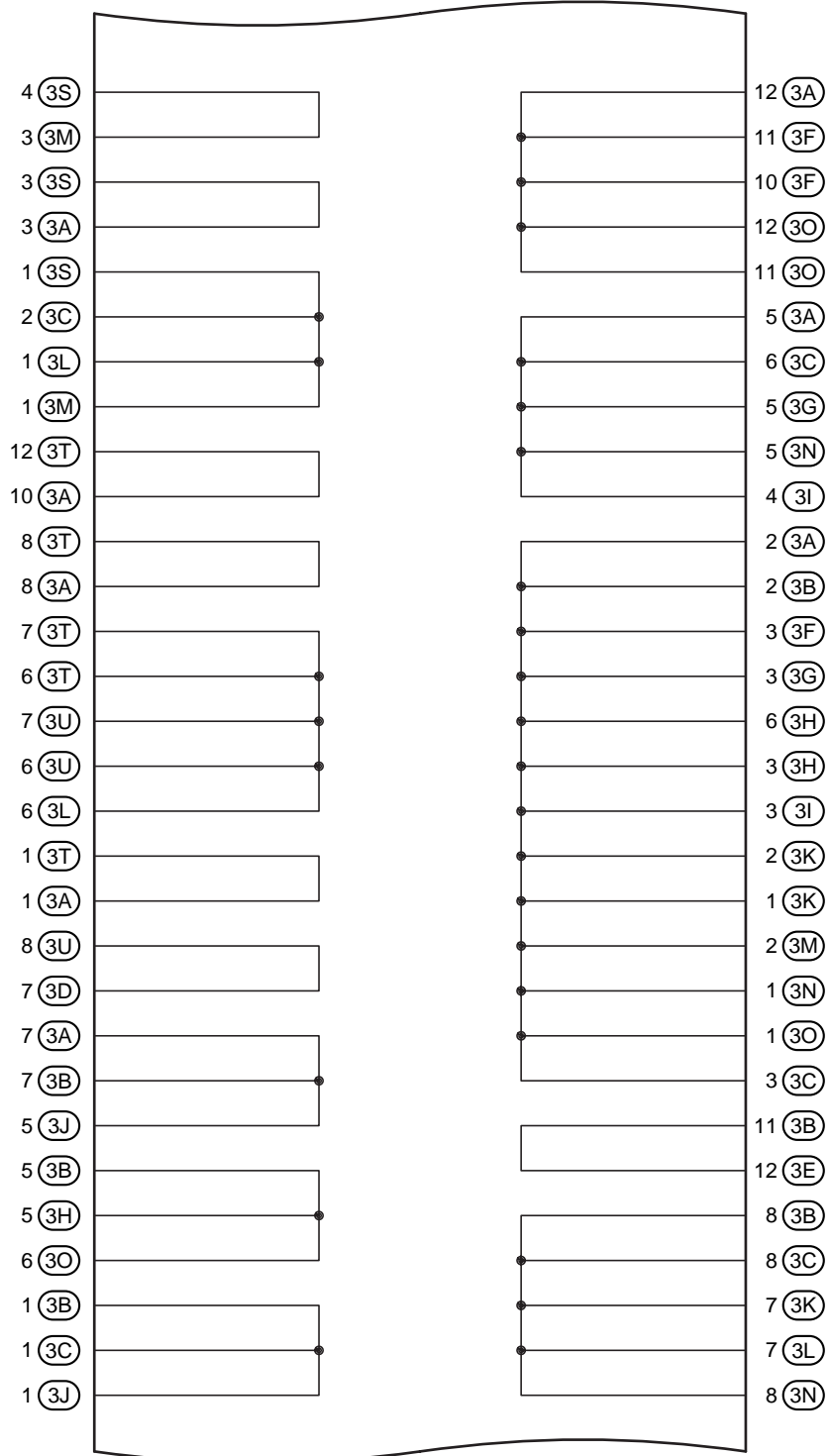

(Cont. Next Page)

(Cont'd)

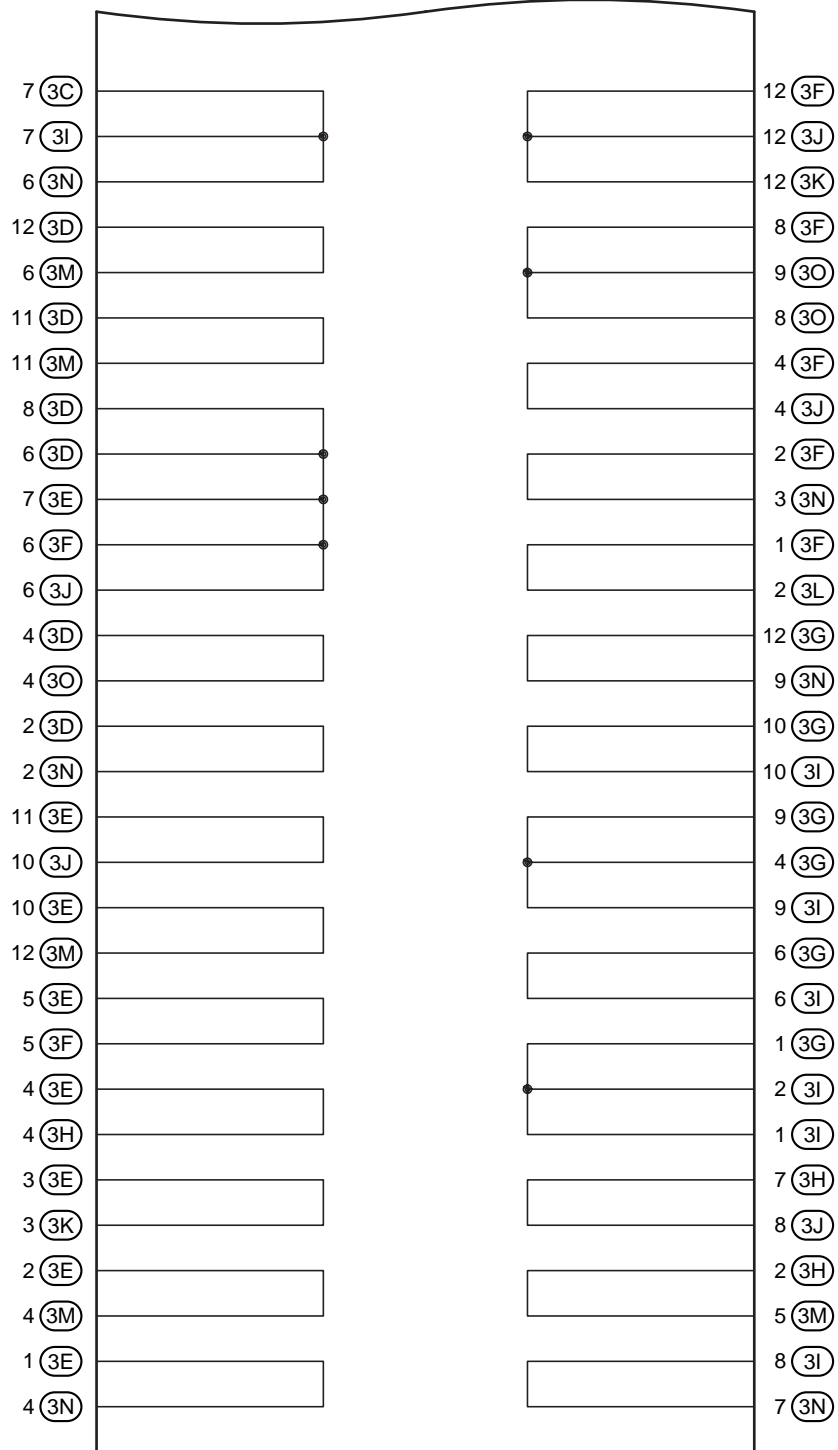

# F RELAY LOCATIONS

○ : J/B No.4      Instrument Panel Brace Center (See Page 20)

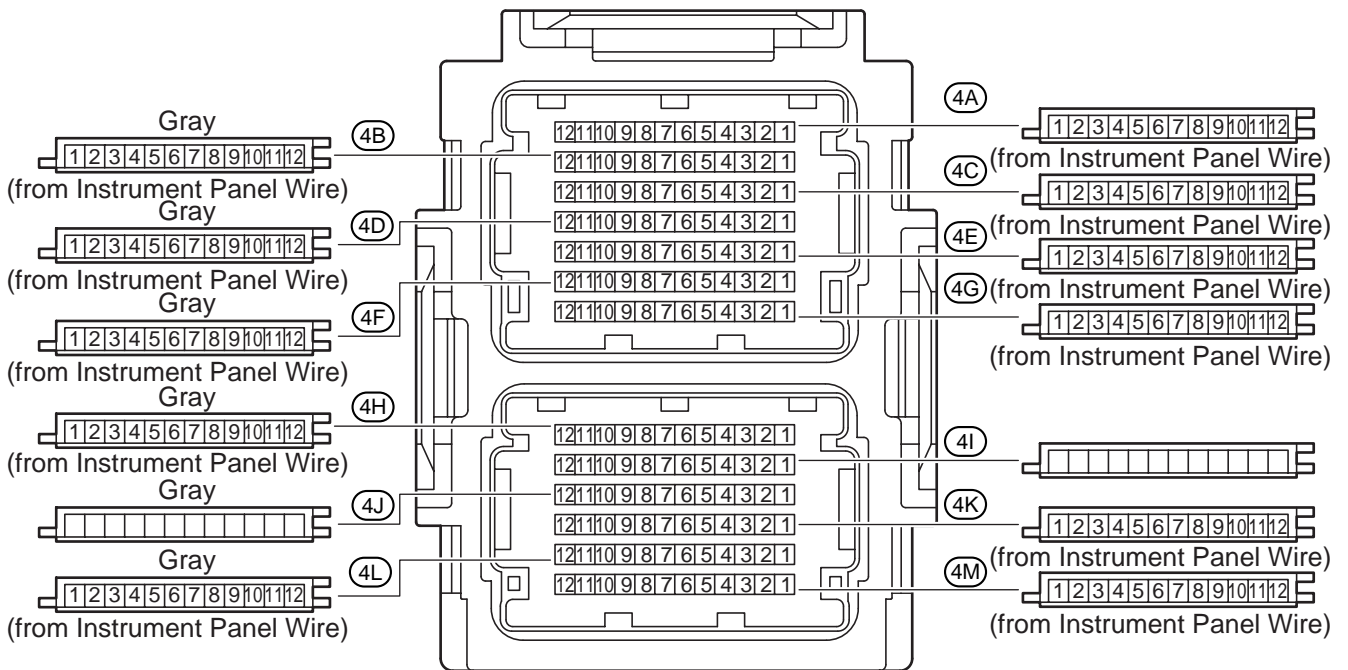

[J/B No.4 Inner Circuit]

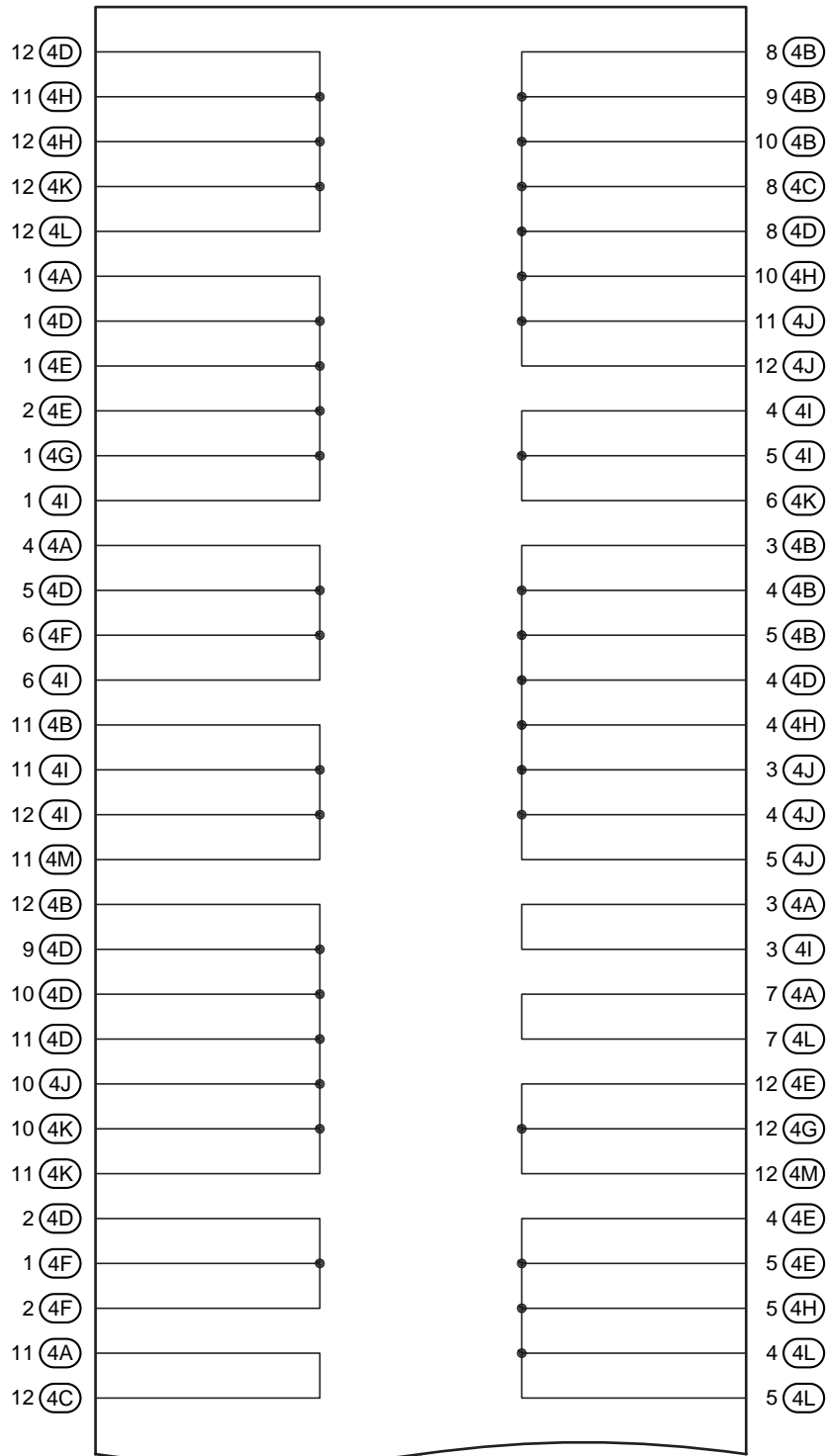

(Cont. Next Page)

# F RELAY LOCATIONS

## [J/B No.4 Inner Circuit]

(Cont'd)

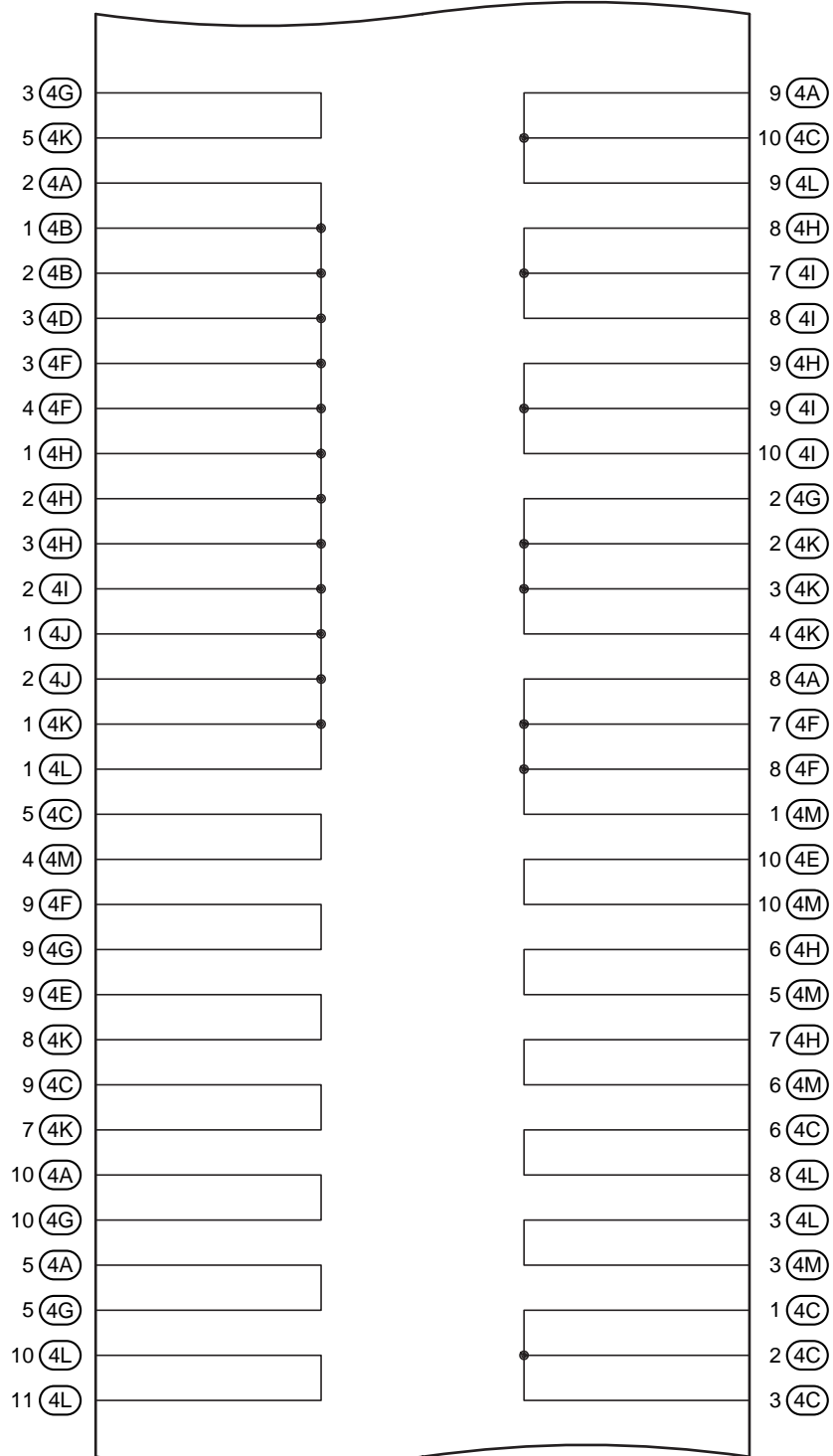

(Cont. Next Page)

(Cont'd)

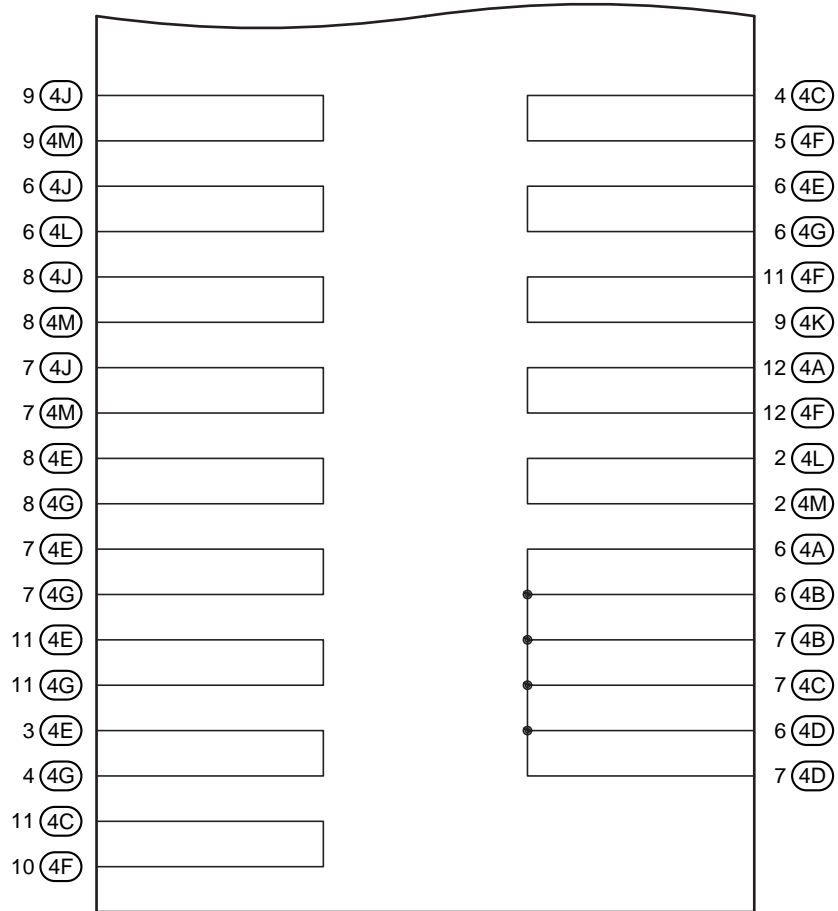

# F RELAY LOCATIONS

Junction Connector (CAN)

Instrument Panel Brace Center (See Page 20)

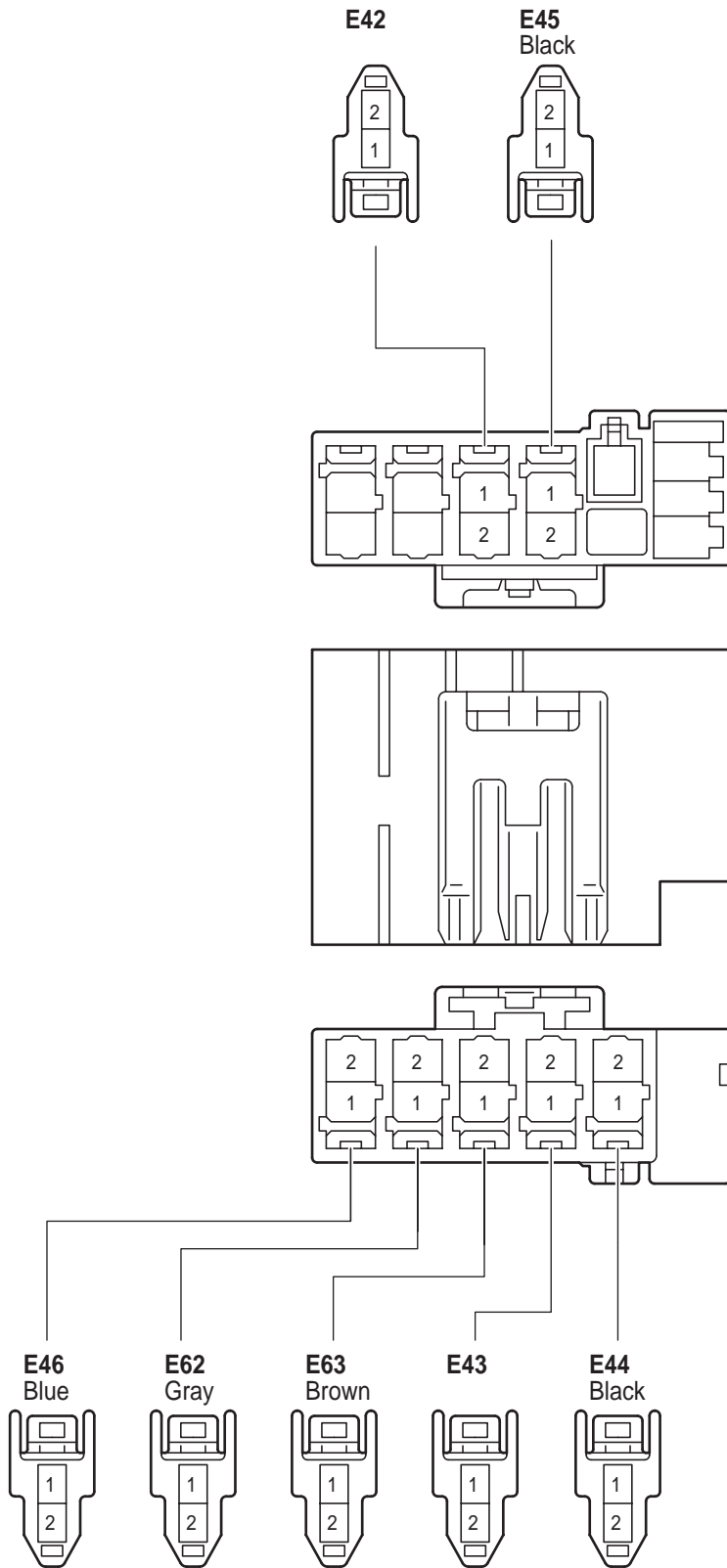

[Junction Connector (CAN) Inner Circuit]

E42(A), E43(B), E44(C), E45(D),  
E46(E), E62(G), E63(H)

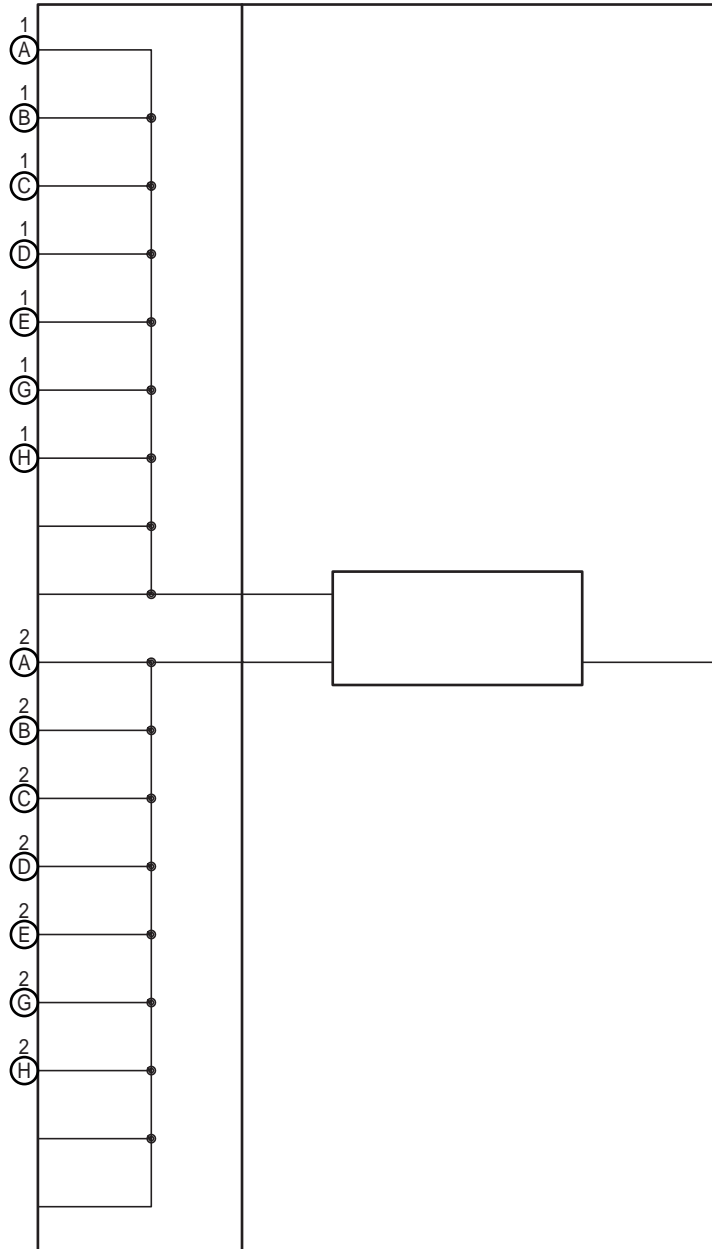



# G ELECTRICAL WIRING ROUTING

## Position of Parts in Engine Compartment

[2GR-FE]

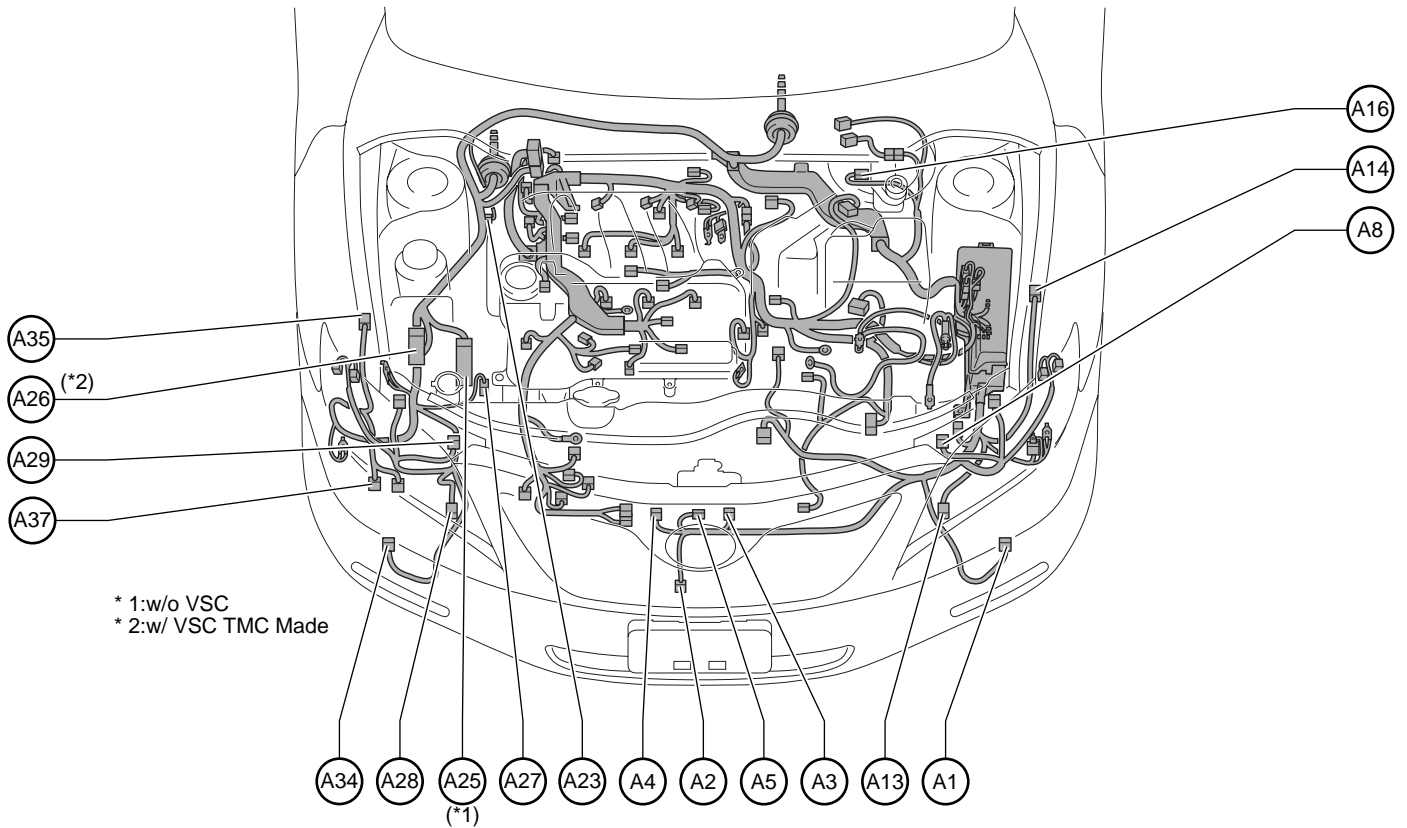

- A 1 Fog Lamp (Front LH)
- A 2 Ambient Temp. Sensor
- A 3 Horn (High)
- A 4 Horn (Low)
- A 5 Engine Hood Courtesy SW
- A 8 Headlamp (LH High)
- A 13 Airbag Sensor (Front LH)
- A 14 Speed Sensor (Front LH)
- A 16 Brake Fluid Level Warning SW

- A 23 Security Horn
- A 25 Skid Control ECU with Actuator
- A 26 Skid Control ECU with Actuator
- A 27 A/C Pressure Sensor
- A 28 Airbag Sensor (Front RH)
- A 29 Headlamp (RH High)
- A 34 Fog Lamp (Front RH)
- A 35 Speed Sensor (Front RH)
- A 37 Windshield Washer Motor

## Position of Parts in Engine Compartment

### [2GR-FE]

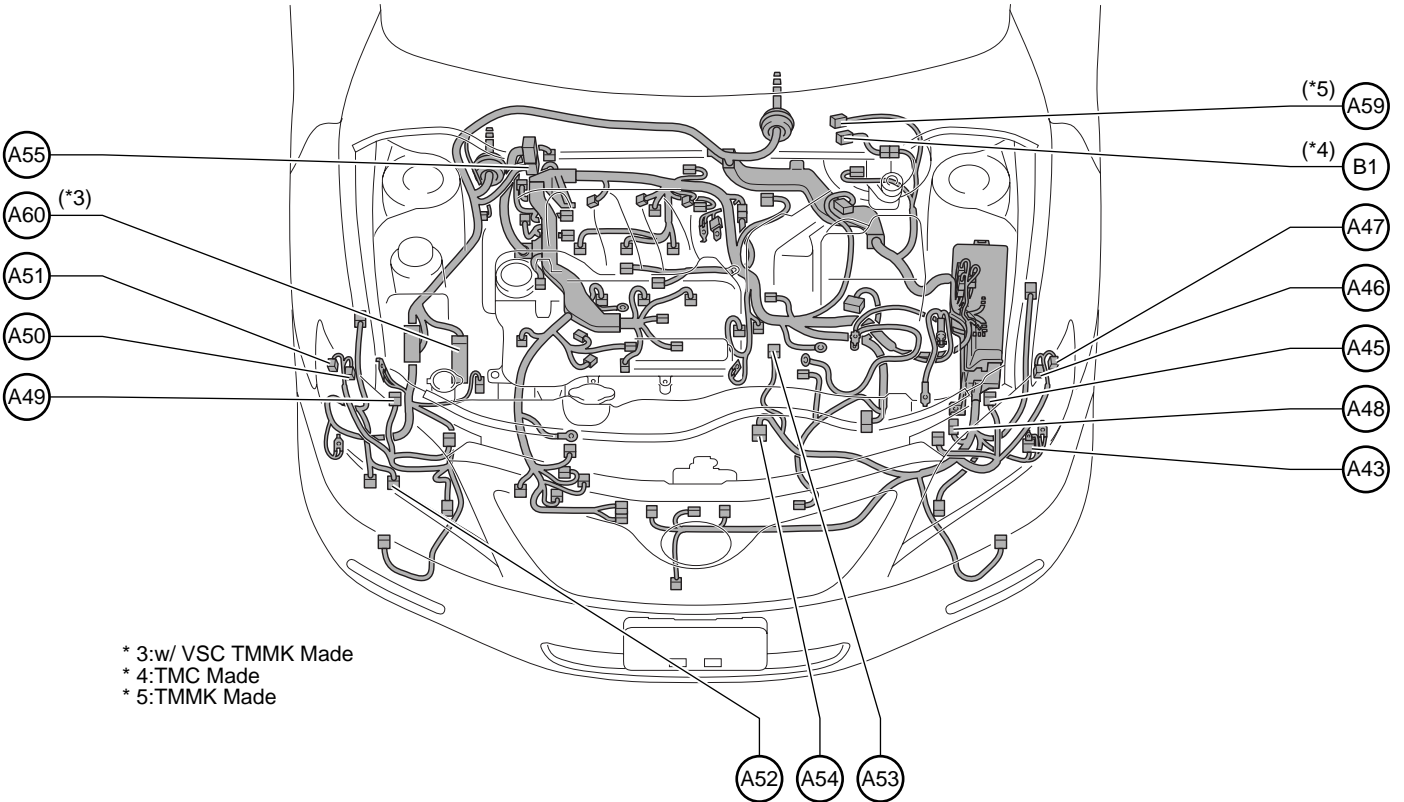

- A 43 Junction Connector
- A 45 Headlamp (LH Low)
- A 46 Turn Signal and Parking Lamp (Front LH)
- A 47 Side Marker Lamp (Front LH)
- A 48 Wireless Door Lock Buzzer
- A 49 Headlamp (RH Low)
- A 50 Turn Signal and Parking Lamp (Front RH)
- A 51 Side Marker Lamp (Front RH)
- A 52 Washer Level Warning SW
- A 53 VSV (Air Intake Control)
- A 54 Cooling Fan ECU
- A 55 Engine Control Module
- A 59 Windshield Wiper Motor
- A 60 Skid Control ECU with Actuator

B 1 Windshield Wiper Motor

# G ELECTRICAL WIRING ROUTING

## Position of Parts in Engine Compartment

[2GR-FE]

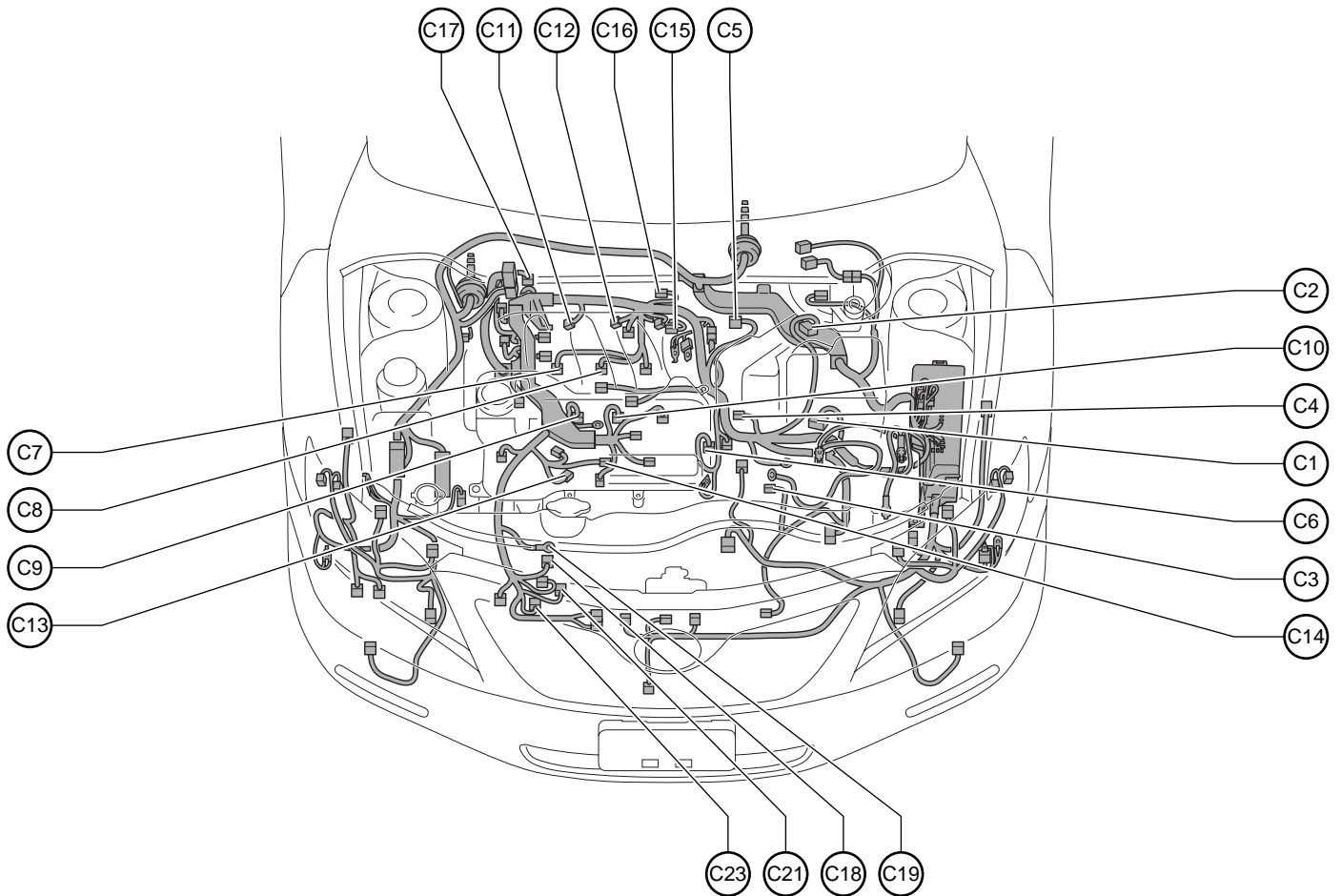

C 1 Park/Neutral Position SW

C 2 Mass Air Flow Meter

C 3 Starter

C 4 Engine Coolant Temp. Sensor

C 5 Throttle Body Assembly

C 6 VSV (Purge)

C 7 Fuel Injector (No.1)

C 8 Fuel Injector (No.3)

C 9 Fuel Injector (No.2)

C10 Fuel Injector (No.4)

C11 Ignition Coil (No.1)

C12 Ignition Coil (No.3)

C13 Ignition Coil (No.2)

C14 Ignition Coil (No.4)

C15 Air Fuel Ratio Sensor (Bank 1 Sensor 1)

C16 Noise Filter (Ignition RH)

C17 Power Steering Oil Pressure SW

C18 Generator

C19 Generator

C21 A/C Compressor

C23 Engine Oil Pressure SW

## Position of Parts in Engine Compartment

### [2GR-FE]

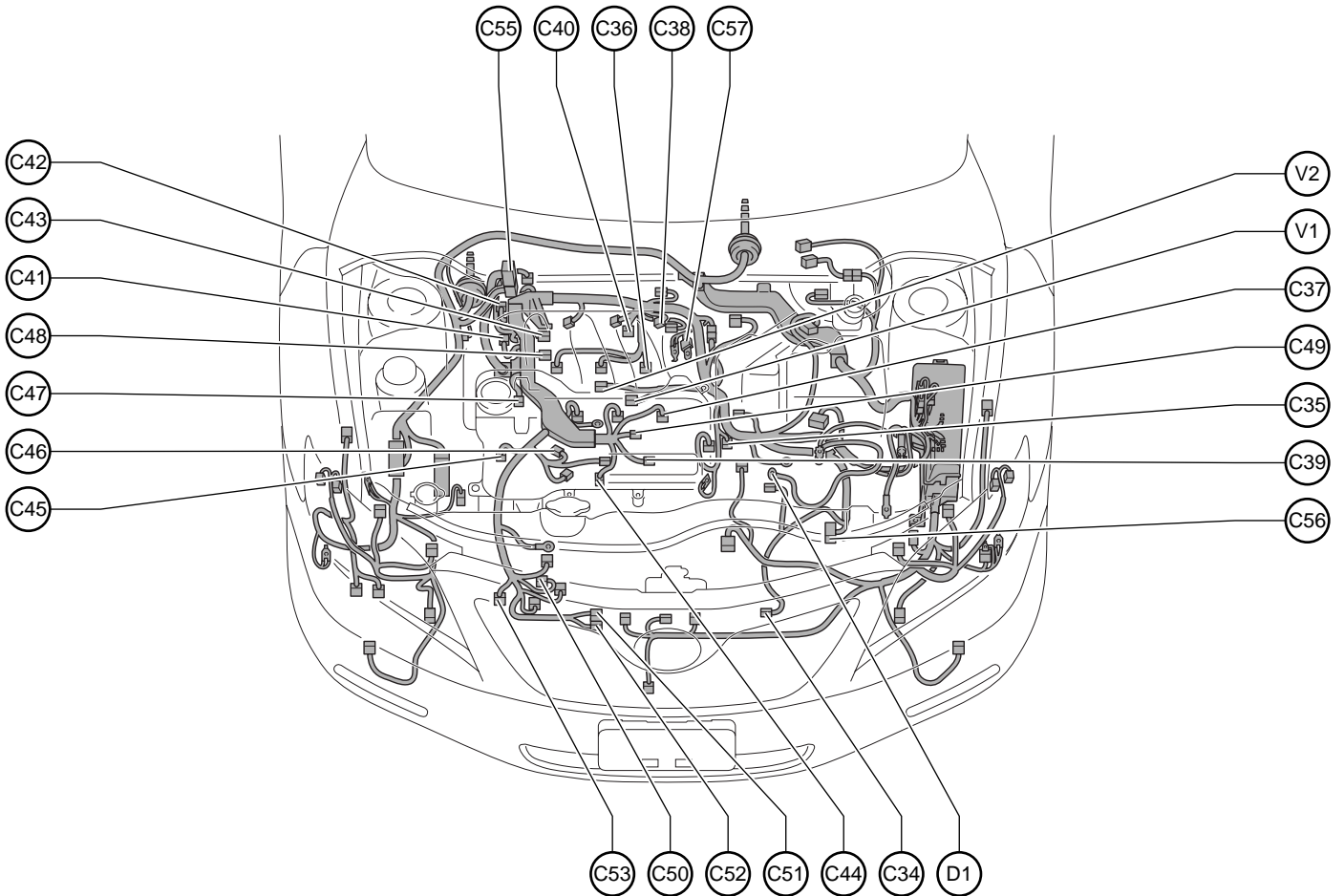

- |   |                                   |
|---|-----------------------------------|
| C34 VSV (ACM)   | D 1 Starter                       |
| C35 Air Fuel Ratio Sensor (Bank 2 Sensor 1)             | V 1 Knock Control Sensor (Bank 2) |
| C36 Fuel Injector (No.5)                                | V 2 Knock Control Sensor (Bank 1) |
| C37 Fuel Injector (No.6)                                |                                   |
| C38 Ignition Coil (No.5)                                |                                   |
| C39 Ignition Coil (No.6)                                |                                   |
| C40 VVT Sensor (Bank 1 Exhaust Side)                    |                                   |
| C41 VVT Sensor (Bank 1 Intake Side)                     |                                   |
| C42 Camshaft Timing Oil Control Valve (RH Exhaust Side) |                                   |
| C43 Camshaft Timing Oil Control Valve (RH Intake Side)  |                                   |
| C44 VVT Sensor (Bank 2 Exhaust Side)                    |                                   |
| C45 VVT Sensor (Bank 2 Intake Side)                     |                                   |
| C46 Camshaft Timing Oil Control Valve (LH Exhaust Side) |                                   |
| C47 Camshaft Timing Oil Control Valve (LH Intake Side)  |                                   |
| C48 VSV (ACIS)  |                                   |
| C49 Noise Filter (Ignition LH)                          |                                   |
| C50 Crankshaft Position Sensor                          |                                   |
| C51 Heated Oxygen Sensor (Bank 2 Sensor 2)              |                                   |
| C52 Heated Oxygen Sensor (Bank 1 Sensor 2)              |                                   |
| C53 A/C Compressor                                      |                                   |
| C55 Engine Control Module                               |                                   |
| C56 Transmission Control ECU                            |                                   |
| C57 Junction Connector                                  |                                   |

# G ELECTRICAL WIRING ROUTING

## Position of Parts in Engine Compartment

[2AZ-FE]

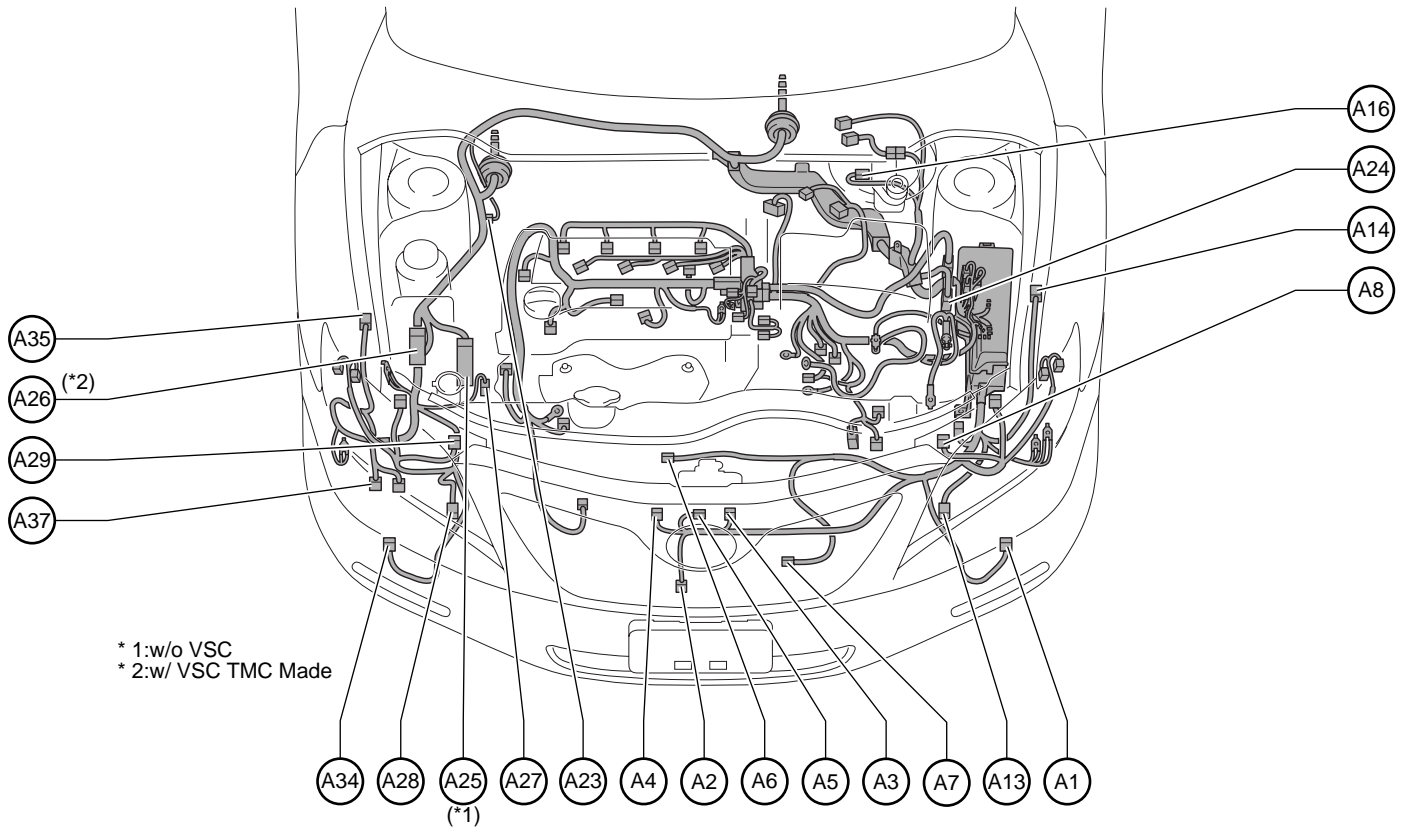

- A 1 Fog Lamp (Front LH)
- A 2 Ambient Temp. Sensor
- A 3 Horn (High)
- A 4 Horn (Low)
- A 5 Engine Hood Courtesy SW
- A 6 A/C Condenser Fan Motor
- A 7 Radiator Fan Motor
- A 8 Headlamp (LH High)
- A 13 Airbag Sensor (Front LH)
- A 14 Speed Sensor (Front LH)
- A 16 Brake Fluid Level Warning SW

- A 23 Security Horn
- A 24 Engine Control Module
- A 25 Skid Control ECU with Actuator
- A 26 Skid Control ECU with Actuator
- A 27 A/C Pressure Sensor
- A 28 Airbag Sensor (Front RH)
- A 29 Headlamp (RH High)
- A 34 Fog Lamp (Front RH)
- A 35 Speed Sensor (Front RH)
- A 37 Windshield Washer Motor

## Position of Parts in Engine Compartment

### [2AZ-FE]

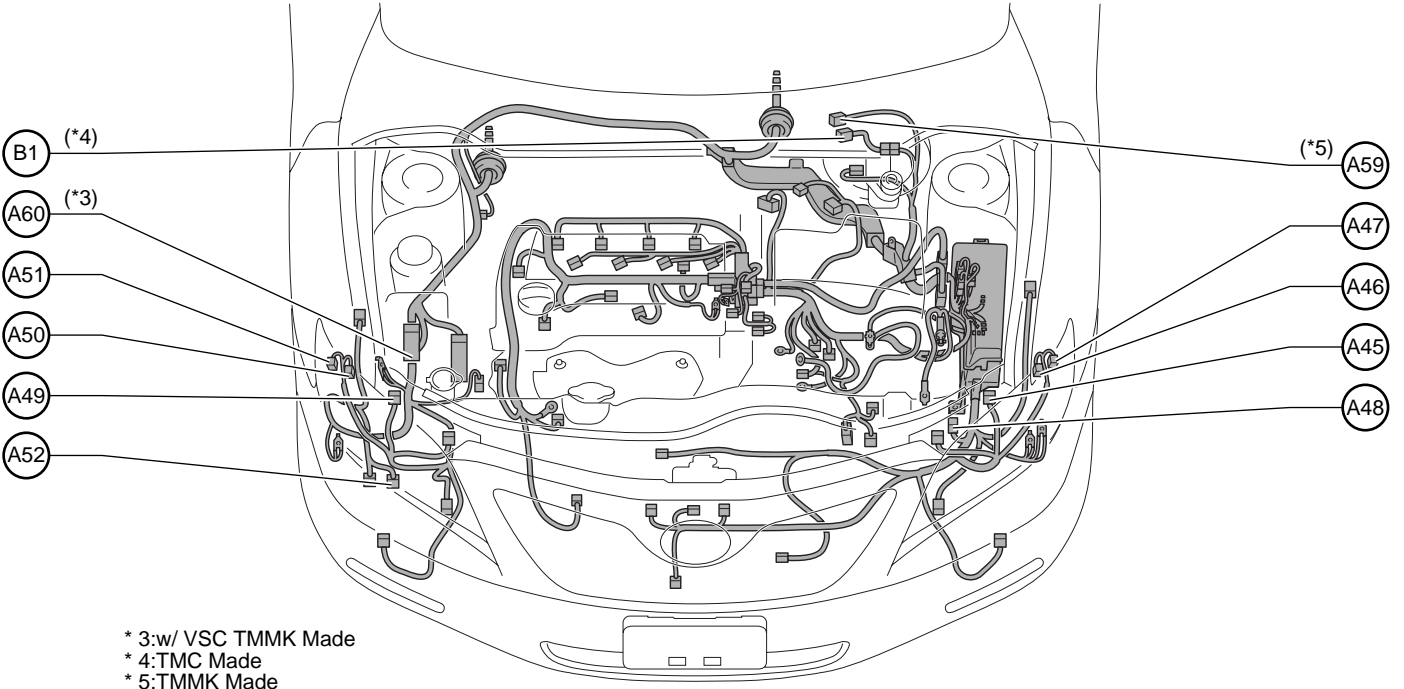

- A45 Headlamp (LH Low)
- A46 Turn Signal and Parking Lamp (Front LH)
- A47 Side Marker Lamp (Front LH)
- A48 Wireless Door Lock Buzzer
- A49 Headlamp (RH Low)
- A50 Turn Signal and Parking Lamp (Front RH)
- A51 Side Marker Lamp (Front RH)
- A52 Washer Level Warning SW
- A59 Windshield Wiper Motor
- A60 Skid Control ECU with Actuator

B 1 Windshield Wiper Motor

# G ELECTRICAL WIRING ROUTING

## Position of Parts in Engine Compartment

[2AZ-FE]

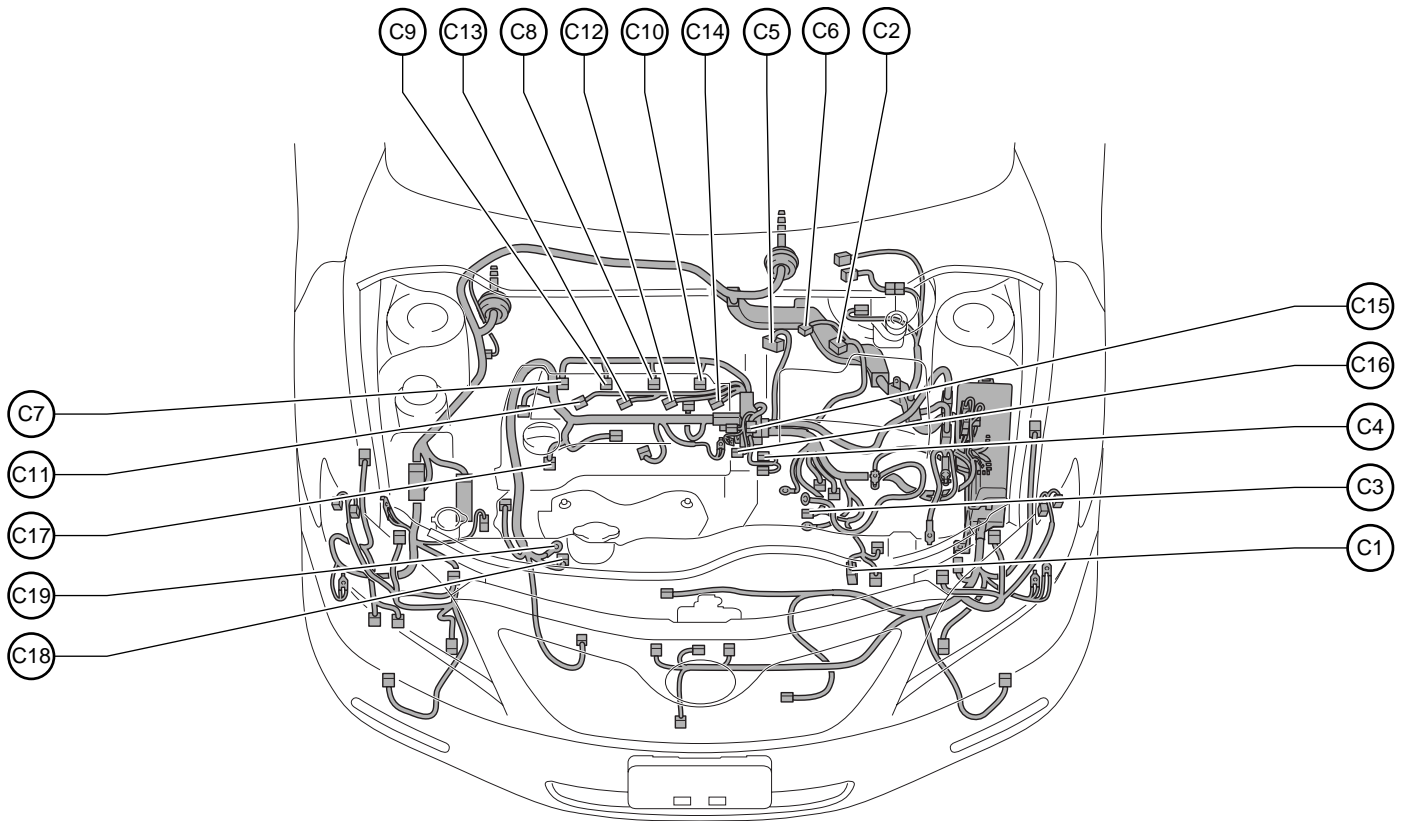

- |                                 |  |
|---------------------------------|--|
| C 1 Park/Neutral Position SW    | C 11 Ignition Coil (No.1)                    |
| C 2 Mass Air Flow Meter         | C 12 Ignition Coil (No.3)                    |
| C 3 Starter                     | C 13 Ignition Coil (No.2)                    |
| C 4 Engine Coolant Temp. Sensor | C 14 Ignition Coil (No.4)                    |
| C 5 Throttle Body Assembly      | C 15 Air Fuel Ratio Sensor (Bank 1 Sensor 1) |
| C 6 VSV (Purge)                 | C 16 Noise Filter (Ignition RH)              |
| C 7 Fuel Injector (No.1)        | C 17 Power Steering Oil Pressure SW          |
| C 8 Fuel Injector (No.3)        | C 18 Generator                               |
| C 9 Fuel Injector (No.2)        | C 19 Generator                               |
| C 10 Fuel Injector (No.4)       |  |

## Position of Parts in Engine Compartment

**[2AZ-FE]**

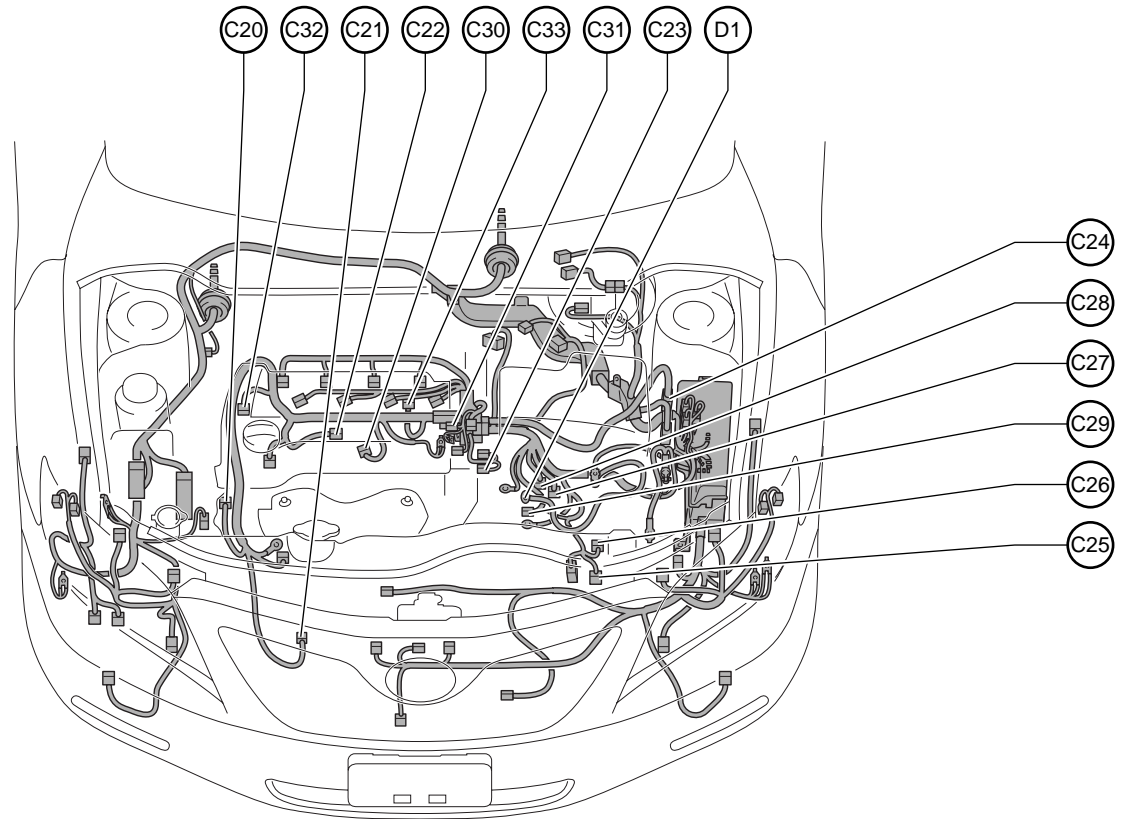

- C20 Crankshaft Position Sensor
- C21 A/C Compressor
- C22 Heated Oxygen Sensor (Bank 1 Sensor 2)
- C23 Engine Oil Pressure SW
- C24 Engine Control Module
- C25 Electronically Controlled Transmission Solenoid
- C26 Transmission Revolution Sensor (Turbine)
- C27 Transmission Revolution Sensor (Counter Gear)
- C28 Back-Up Lamp SW
- C29 Starter
- C30 Knock Control Sensor (Bank 1)
- C31 Camshaft Position Sensor
- C32 Camshaft Timing Oil Control Valve
- C33 Intake Air Control Valve

D 1 Starter



# G ELECTRICAL WIRING ROUTING

## Position of Parts in Instrument Panel

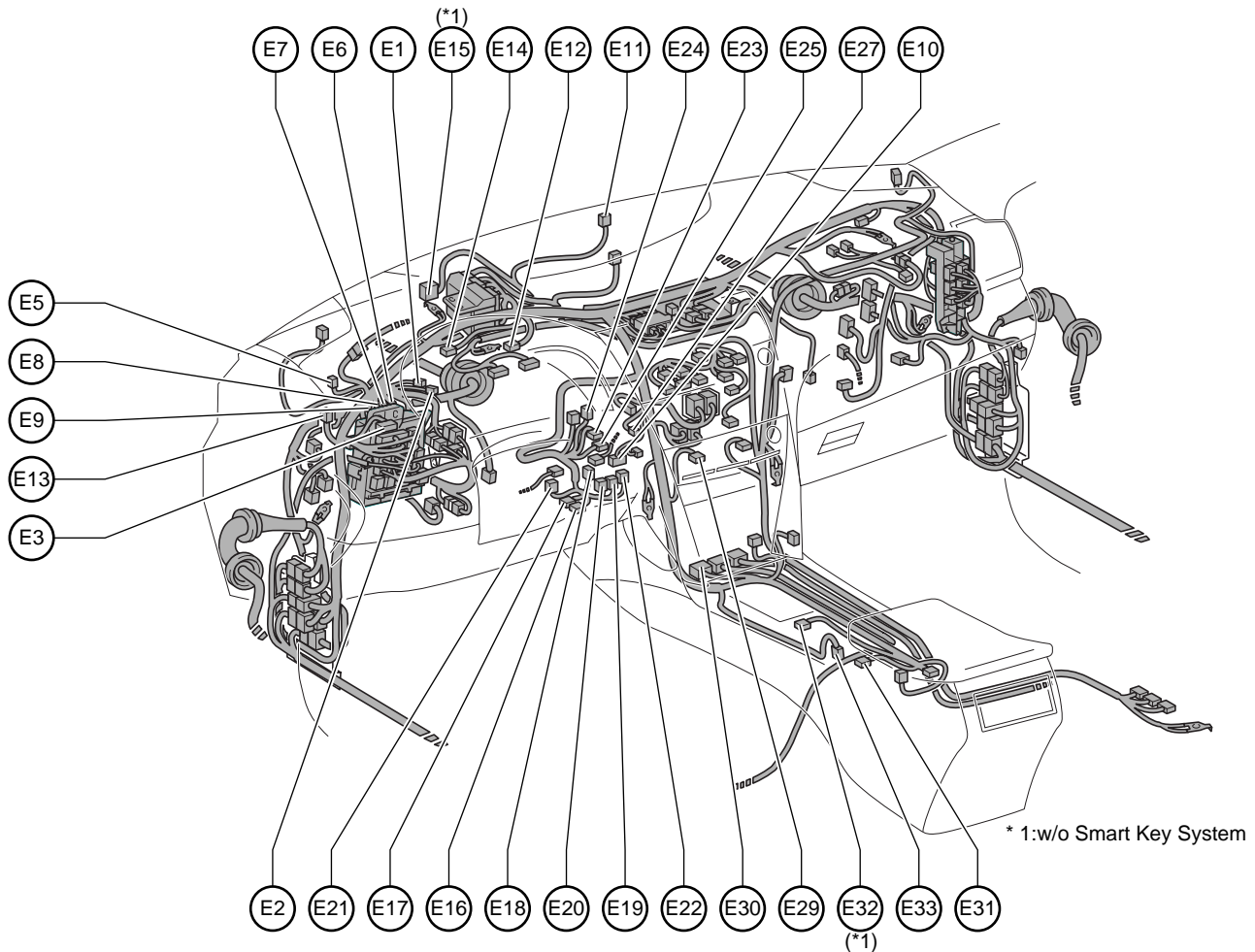

- E 1 Diode (Door Courtesy Rear LH)
- E 2 Diode (Door Courtesy Rear RH)
- E 3 Outer Mirror SW
- E 5 Diode (Door Courtesy Front LH)
- E 6 Main Body ECU
- E 7 Main Body ECU
- E 8 Main Body ECU
- E 9 Main Body ECU
- E 10 Data Link Connector 3
- E 11 Automatic Light Control Sensor
- E 12 Ion Generator
- E 13 VSC Warning Buzzer
- E 14 Turn Signal Flasher
- E 15 Transponder Key ECU
- E 16 Airbag Squib (Steering Wheel Pad)

- E 17 Steering Sensor
- E 18 Spiral Cable
- E 19 Windshield Wiper SW Assembly
- E 20 Windshield Wiper SW Assembly
- E 21 Headlamp Dimmer SW Assembly
- E 22 Unlock Warning SW
- E 23 Ignition SW
- E 24 Key Interlock Solenoid
- E 25 Transponder Key Amplifier
- E 27 A/C Room Temp. Sensor
- E 29 Power Outlet Socket (Front)
- E 30 Airbag Sensor Assembly Center
- E 31 Transmission Control SW
- E 32 Shift Lock Control ECU
- E 33 Parking Brake SW

## Position of Parts in Instrument Panel

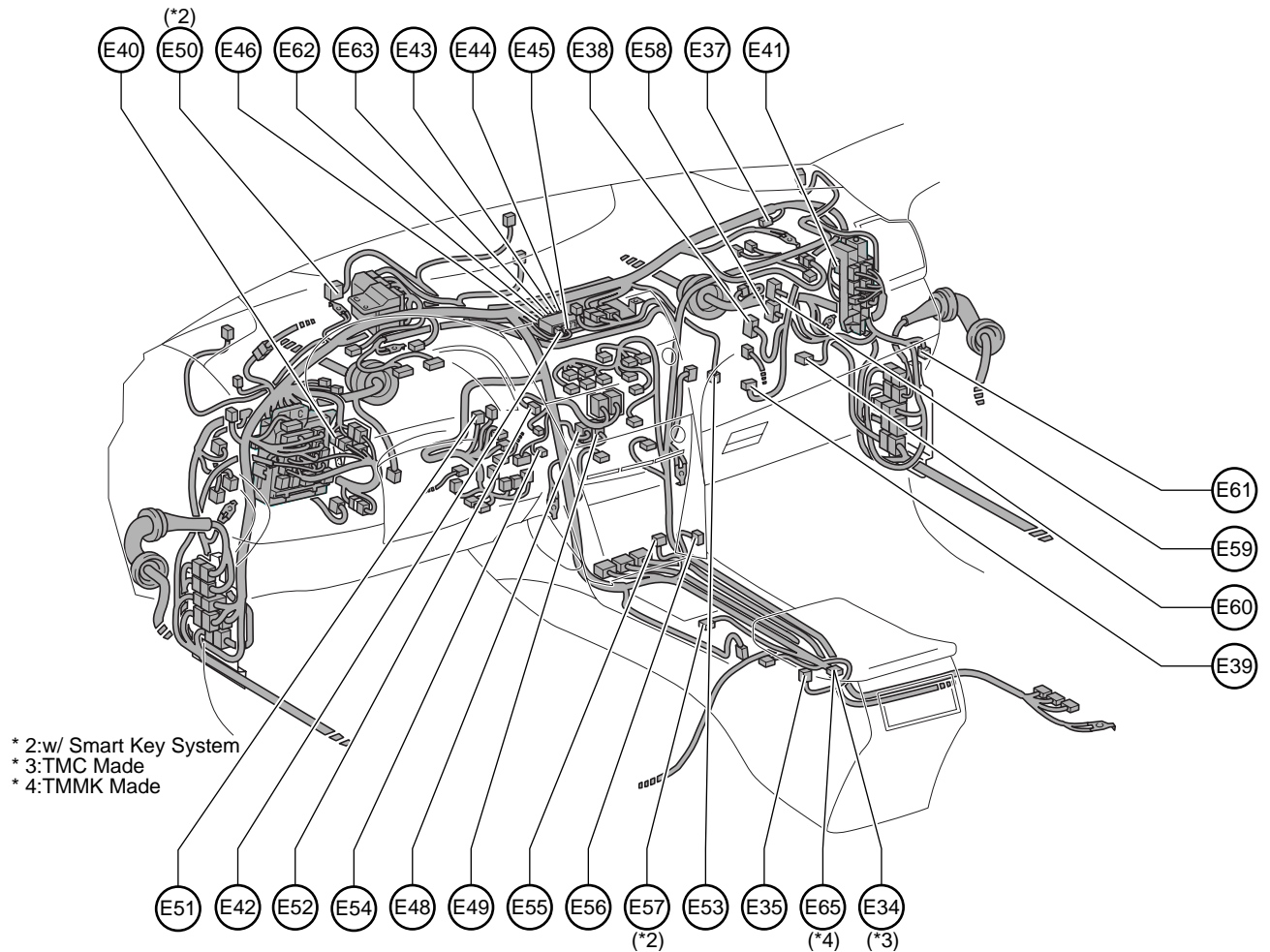

E34 Yaw Rate Sensor  
 E35 Power Outlet Socket (Rear)  
 E37 Diode (Door Courtesy Front RH)  
 E38 A/C Amplifier  
 E39 Blower Motor  
 E40 Junction Connector  
 E41 Junction Connector  
 E42 Junction Connector  
 E43 Junction Connector  
 E44 Junction Connector  
 E45 Junction Connector  
 E46 Junction Connector  
 E48 Junction Connector  
 E49 Junction Connector  
 E50 ID Code Box

E51 Steering Lock ECU  
 E52 Power SW  
 E53 Tire Pressure Warning SW (Reset)  
 E54 Airbag Squib (Knee Airbag)  
 E55 Seat Heater SW  
 E56 Electrical Key Oscillator (Console)  
 E57 Shift Lock Control ECU  
 E58 Certification ECU  
 E59 Certification ECU  
 E60 Tire Pressure Warning ECU  
 E61 Option Connector (Bus Buffer)  
 E62 Junction Connector  
 E63 Junction Connector  
 E65 Yaw Rate Sensor

# G ELECTRICAL WIRING ROUTING

## Position of Parts in Instrument Panel

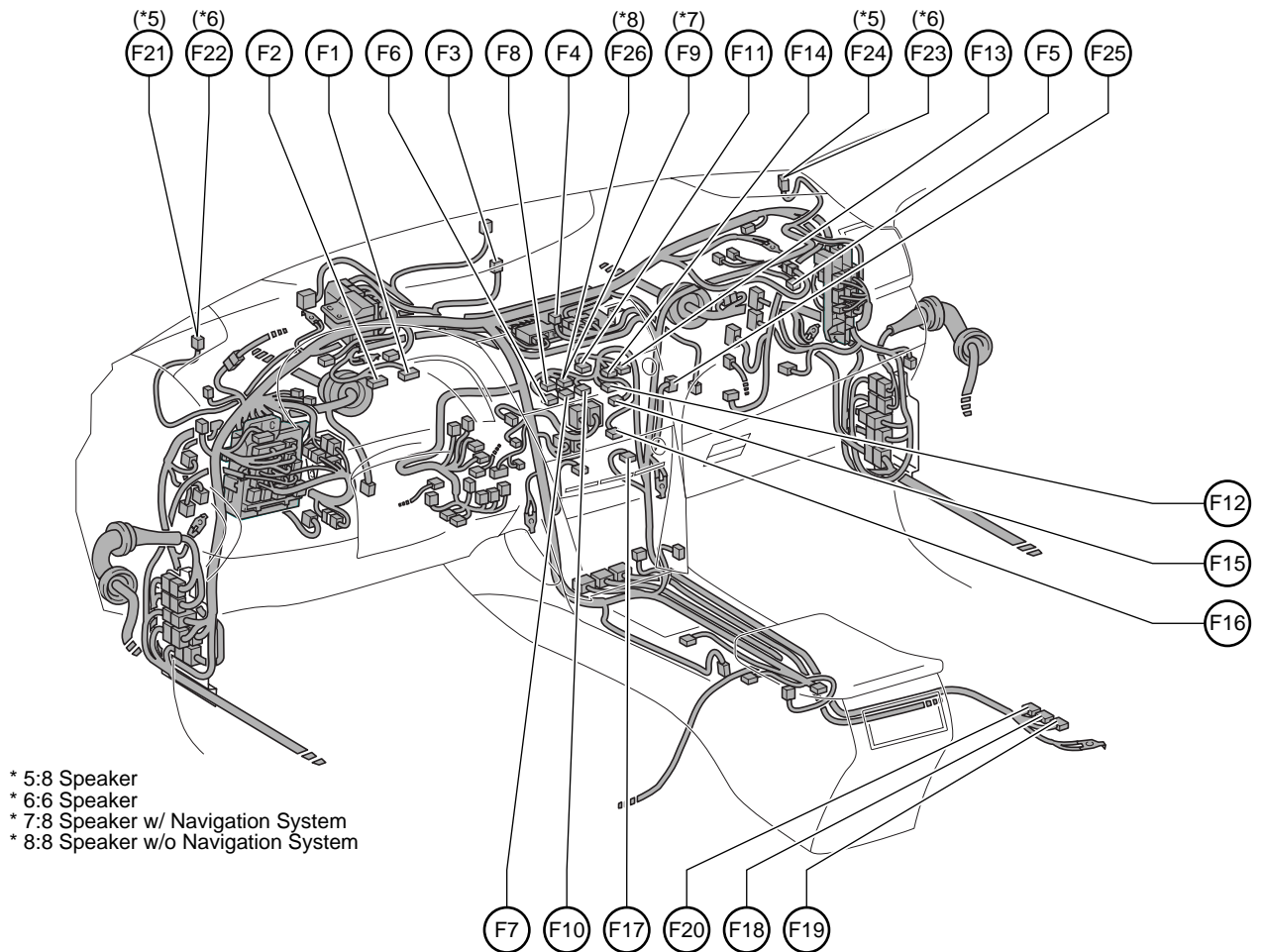

- |      |                              |      |                              |
|------|------------------------------|------|------------------------------|
| F 1  | Combination Meter            | F 14 | Navigation Receiver Assembly |
| F 2  | Combination Meter            | F 15 | Antenna Amplifier            |
| F 3  | Clock                        | F 16 | A/C Control Assembly         |
| F 4  | Hazard Warning Signal SW     | F 17 | Stereo Jack Adapter          |
| F 5  | Glove Box Lamp               | F 18 | Stereo Component Amplifier   |
| F 6  | Radio Receiver Assembly      | F 19 | Stereo Component Amplifier   |
| F 7  | Radio Receiver Assembly      | F 20 | Stereo Component Amplifier   |
| F 8  | Radio Receiver Assembly      | F 21 | Tweeter (Front LH)           |
| F 9  | Navigation Receiver Assembly | F 22 | Tweeter (Front LH)           |
| F 10 | Navigation Receiver Assembly | F 23 | Tweeter (Front RH)           |
| F 11 | Radio Receiver Assembly      | F 24 | Tweeter (Front RH)           |
| F 12 | Navigation Receiver Assembly | F 25 | Junction Connector           |
| F 13 | Navigation Receiver Assembly | F 26 | Radio Receiver Assembly      |

## Position of Parts in Instrument Panel

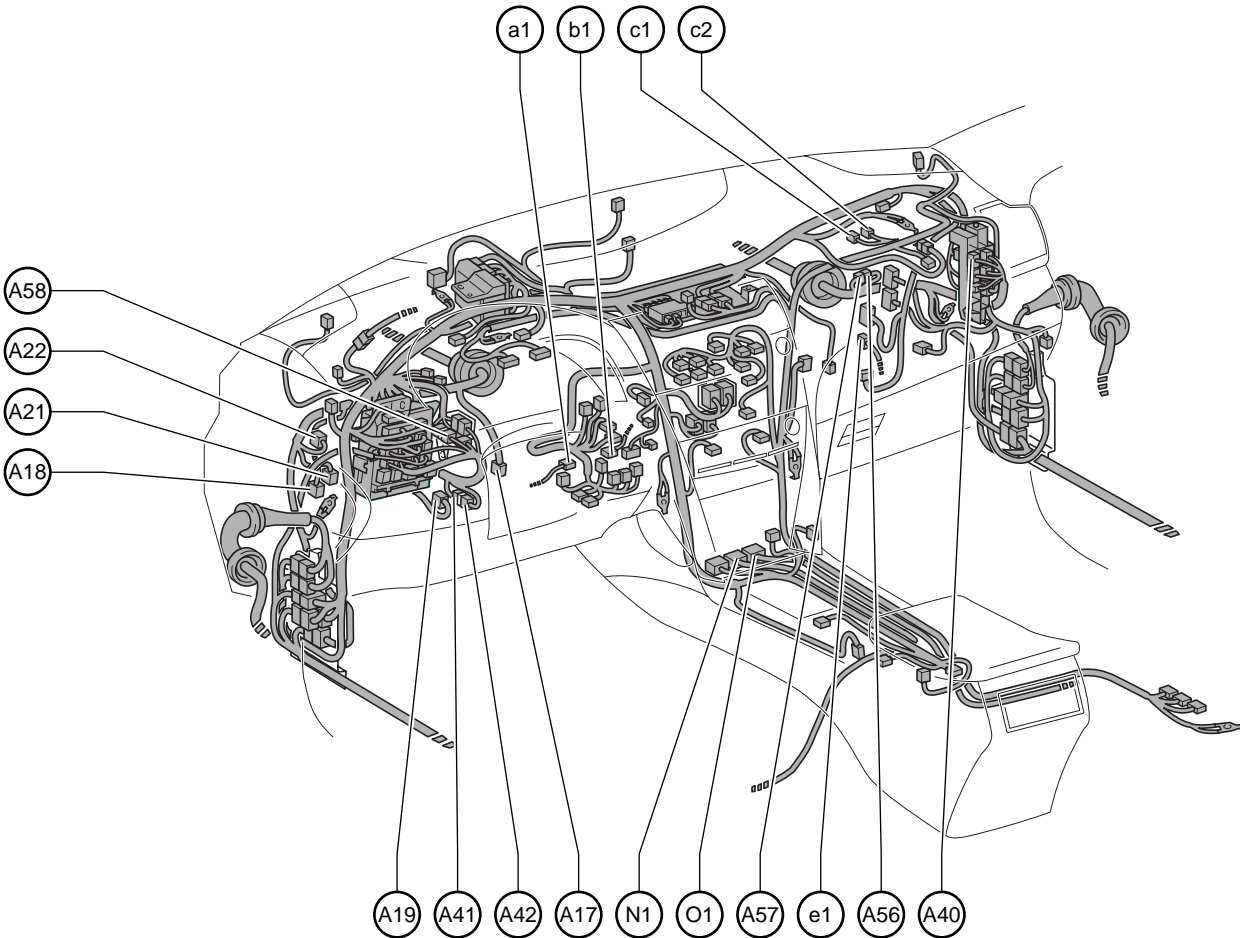

A17 Accelerator Position Sensor  
 A18 Parking Brake SW  
 A19 Stop Lamp SW  
 A21 Cruise Control Clutch SW  
 A22 Clutch Start SW  
 A40 Junction Connector  
 A41 Junction Connector  
 A42 Junction Connector  
 A56 Short Connector  
 A57 Short Connector  
 A58 Junction Connector

N 1 Airbag Sensor Assembly Center

O 1 Airbag Sensor Assembly Center

a 1 Spiral Cable  
Steering Pad SW

b 1 Cruise Control SW  
Spiral Cable

c 1 Airbag Squib (Front Passenger's Airbag Assembly)

c 2 Airbag Squib (Front Passenger's Airbag Assembly)

e 1 A/C Amplifier  
A/C Blower Assembly

# G ELECTRICAL WIRING ROUTING

## Position of Parts in Body

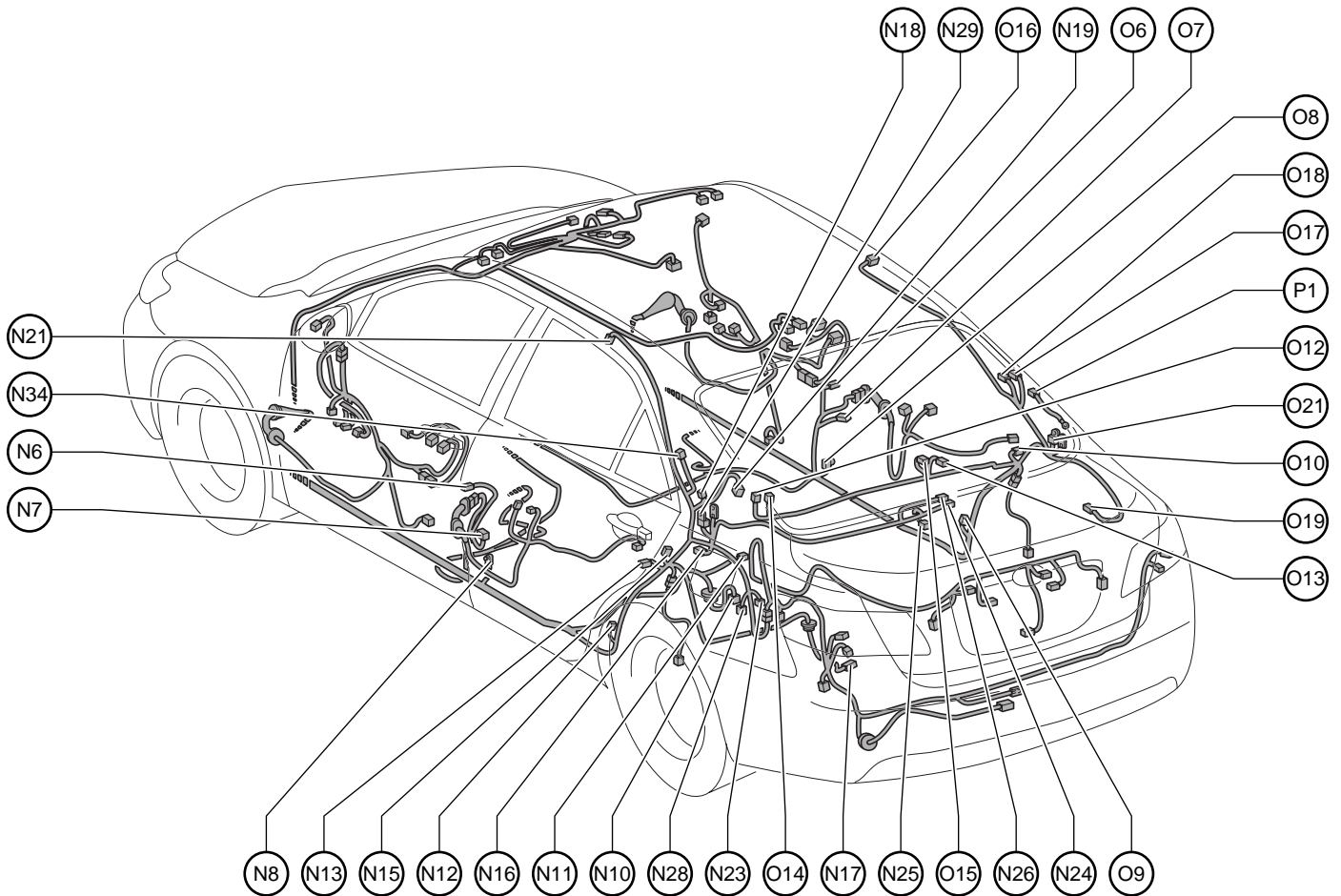

- N 6 Door Courtesy SW (Driver's Side)
- N 7 Side Airbag Sensor (Front LH)
- N 8 Pretensioner (LH)
- N10 Fuel Suction Pump and Gage Assembly
- N11 Electrical Key Oscillator (Rear Seat)
- N12 Side Airbag Sensor (Rear LH)
- N13 Door Courtesy SW (Rear LH)
- N15 Noise Filter (Dome and Stop)
- N16 Center Stop Lamp
- N17 Canister Pump Module
- N18 Noise Filter (Rear Window Defogger)
- N19 Rear Window Defogger
- N21 Curtain Shield Airbag Squib (LH)
- N23 Diode (Luggage Compartment Lamp)
- N24 Luggage Compartment Lamp
- N25 Electrical Key Oscillator (Inside Luggage Room)
- N26 Luggage Compartment Lamp
- N28 Junction Connector
- N29 Junction Connector
- N34 Tire Pressure Warning Antenna and Receiver

- O 6 Door Courtesy SW (Front Passenger's Side)
- O 7 Side Airbag Sensor (Front RH)
- O 8 Pretensioner (RH)
- O 9 Side Airbag Sensor (Rear RH)
- O10 Door Courtesy SW (Rear RH)
- O12 Speaker (Rear LH)
- O13 Speaker (Rear RH)
- O14 Speaker (Rear LH)
- O15 Speaker (Rear RH)
- O16 Curtain Shield Airbag Squib (RH)
- O17 Door Control Receiver
- O18 Door Control Receiver
- O19 Electrical Key Antenna
- O21 Junction Connector
  
- P 1 Rear Window Defogger

**Position of Parts in Body**

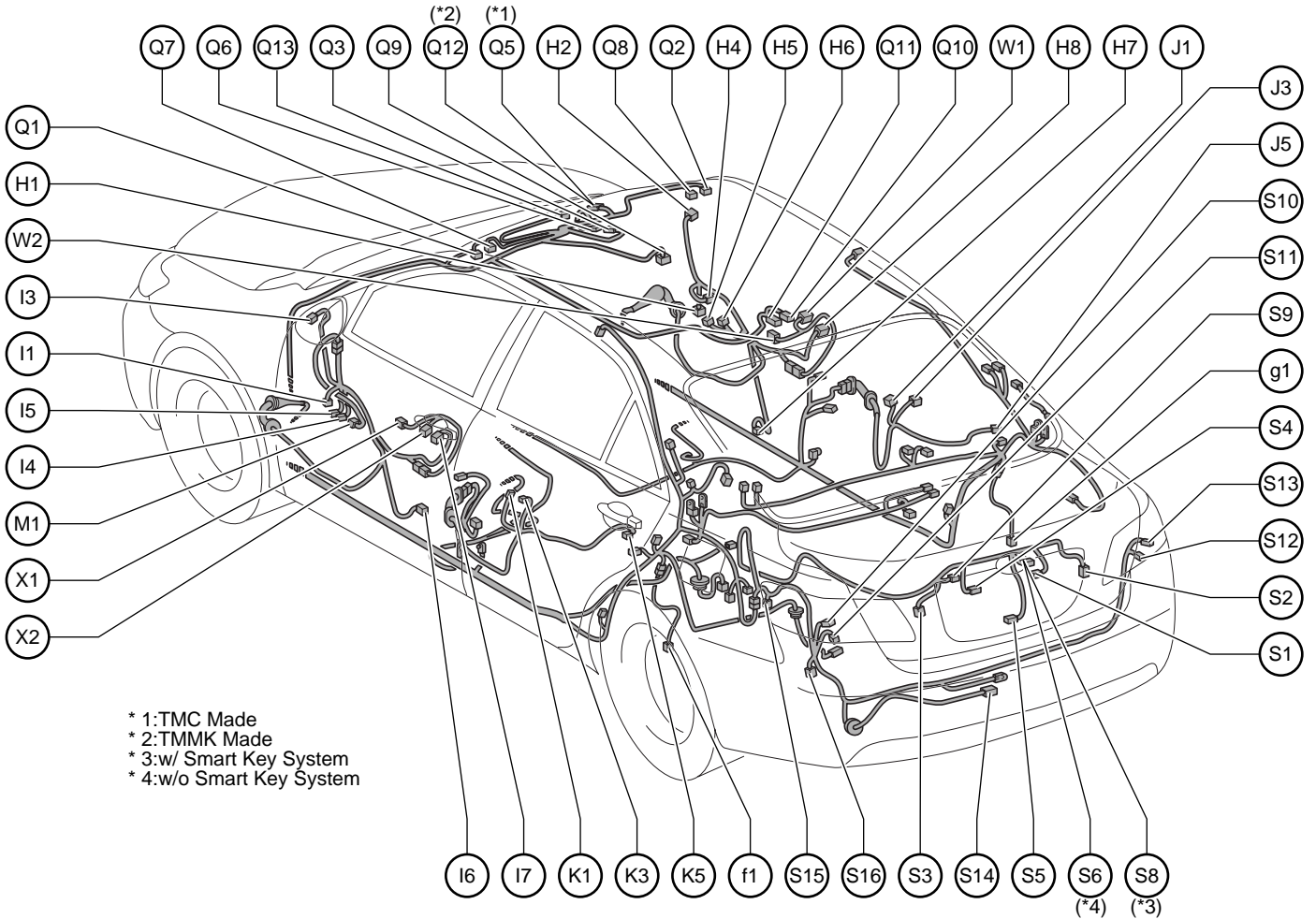

\* 1:TMC Made  
 \* 2:TMMK Made  
 \* 3:w/ Smart Key System  
 \* 4:w/o Smart Key System

- H 1 Speaker (Front Door RH)
- H 2 Outer Rear View Mirror (RH)
- H 4 Power Window Regulator Motor (Front Passenger's Side)
- H 5 Door Lock Control SW
- H 6 Power Window SW (Front Passenger's Side)
- H 7 Courtesy Lamp (Front Door RH)
- H 8 Door Lock Assembly (Front Passenger's Side)

- I 1 Speaker (Front Door LH)
- I 3 Outer Rear View Mirror (LH)
- I 4 Power Window Regulator Motor (Front LH)
- I 5 Power Window Regulator Motor (Front LH)
- I 6 Courtesy Lamp (Front Door LH)
- I 7 Door Lock Assembly (Driver's Side)

- J 1 Power Window SW (Rear RH)
- J 3 Power Window Regulator Motor (Rear RH)
- J 5 Door Lock Assembly (Rear RH)

- K 1 Power Window SW (Rear LH)
- K 3 Power Window Regulator Motor (Rear LH)
- K 5 Door Lock Assembly (Rear LH)

- M 1 Power Window Master SW

- Q 1 Vanity Lamp SW (LH)
- Q 2 Vanity Lamp SW (RH)
- Q 3 Inner Rear View Mirror
- Q 5 Microphone (Navigation)
- Q 6 Overhead J/B
- Q 7 Vanity Lamp (LH)

- Q 8 Vanity Lamp (RH)
- Q 9 Room Lamp (Center)
- Q10 Map Lamp (RH)
- Q11 Map Lamp (LH)
- Q12 Microphone (Navigation)
- Q13 Sliding Roof Control ECU and Motor

- S 1 License Plate Lamp (RH)
- S 2 Rear Combination Lamp (RH)
- S 3 Rear Combination Lamp (LH)
- S 4 License Plate Lamp (LH)
- S 5 Door Lock Assembly (Luggage)
- S 6 Luggage Compartment Door Lock Cylinder
- S 8 Luggage Compartment Door Lock Cylinder
- S 9 Luggage Electrical Key SW
- S10 Turn Signal Lamp (Rear LH)
- S11 Rear Combination Lamp (LH)
- S12 Rear Combination Lamp (RH)
- S13 Turn Signal Lamp (Rear RH)
- S14 Electrical Key Oscillator (Outside Luggage Room)
- S15 Junction Connector
- S16 Junction Connector

- W 1 Door Outside Handle (Front RH)
- W 2 Electrical Key Oscillator (Front Door RH)

- X 1 Door Outside Handle (Front LH)
- X 2 Electrical Key Oscillator (Front Door LH)

- f 1 Speed Sensor (Rear LH)

- g 1 Speed Sensor (Rear RH)

# G ELECTRICAL WIRING ROUTING

## Position of Parts in Seat

[w/ Power Seat]

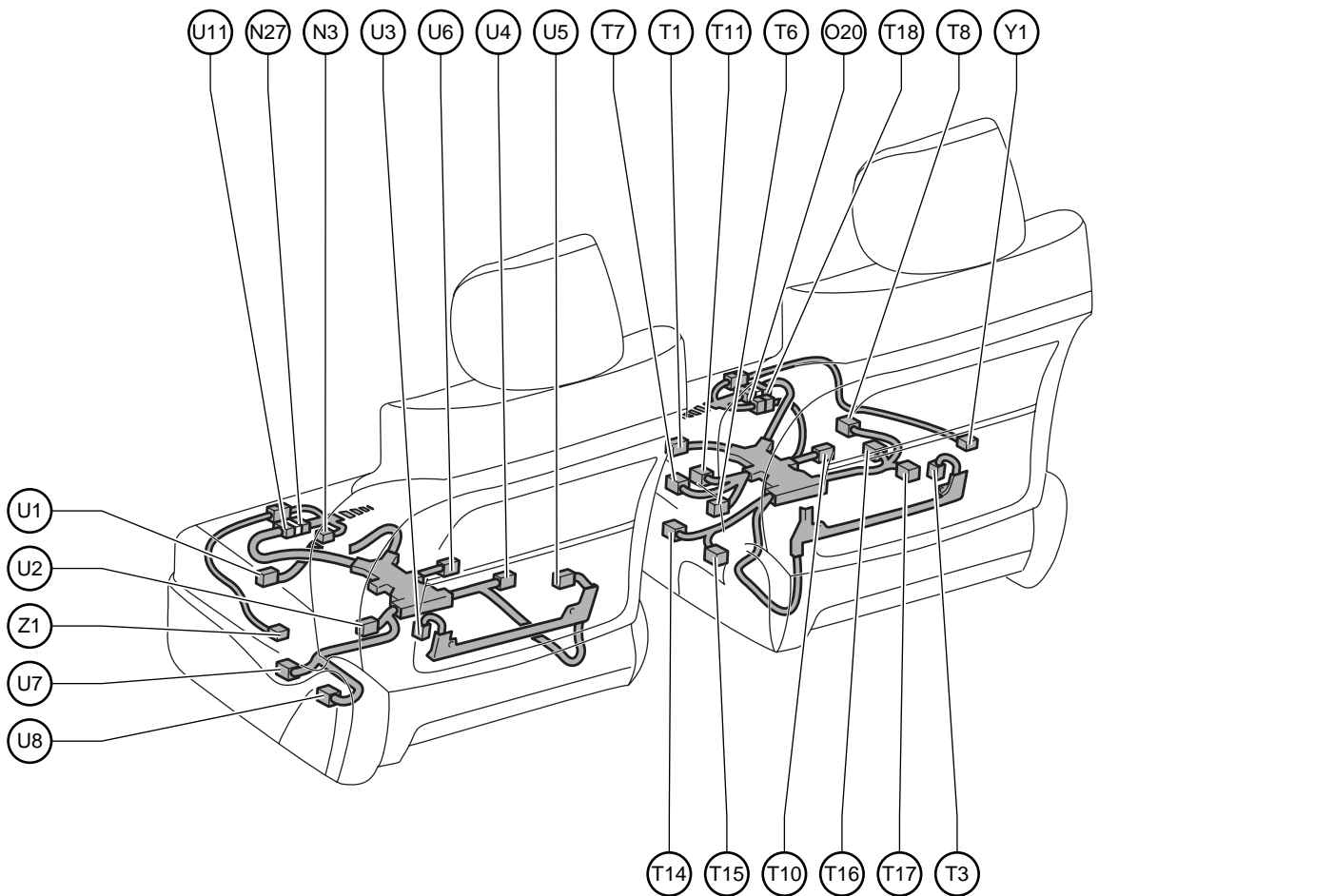

N 3 Front Seat Inner Belt (Driver's Side)  
N27 Junction Connector

O20 Junction Connector

T 1 Power Seat Motor  
(Front Passenger's Seat Slide Control)  
T 3 Power Seat Motor  
(Front Passenger's Seat Reclining Control)  
T 6 Seat Heater (RH)  
T 7 Front Seat Inner Belt (Front Passenger's Side)  
T 8 Power Seat SW (Front Passenger's Seat)  
T 10 Occupant Classification ECU  
T 11 Occupant Classification ECU  
T 14 Occupant Classification Sensor (Front LH)  
T 15 Occupant Classification Sensor (Rear LH)  
T 16 Occupant Classification Sensor (Front RH)  
T 17 Occupant Classification Sensor (Rear RH)  
T 18 Junction Connector

U 1 Power Seat Motor (Driver's Seat Slide Control)  
U 2 Power Seat Motor (Driver's Seat Front Vertical Control)  
U 3 Power Seat Motor (Driver's Seat Reclining Control)  
U 4 Power Seat Motor (Driver's Seat Lifter Control)  
U 5 Power Seat Motor  
(Driver's Seat Lumbar Support Control)  
U 6 Seat Heater (LH)  
U 7 Power Seat SW (Driver's Seat)  
U 8 Power Seat SW (Driver's Seat Lumbar Support Control)  
U 11 Junction Connector  
Y 1 Side Airbag Squib (RH)  
Z 1 Side Airbag Squib (LH)

## Position of Parts in Seat

[w/o Power Seat]

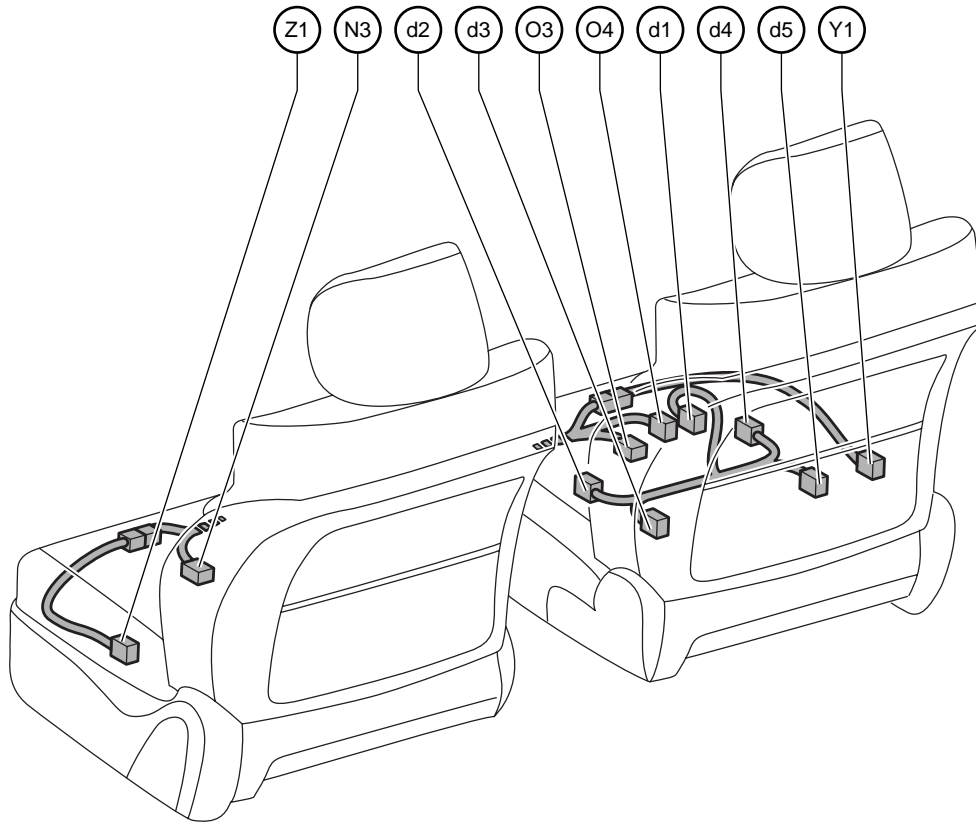

N 3 Front Seat Inner Belt (Driver's Side)

O 3 Front Seat Inner Belt (Front Passenger's Side)

O 4 Occupant Classification ECU

Y 1 Side Airbag Squib (RH)

Z 1 Side Airbag Squib (LH)

d 1 Occupant Classification ECU

d 2 Occupant Classification Sensor (Front LH)

d 3 Occupant Classification Sensor (Rear LH)

d 4 Occupant Classification Sensor (Front RH)

d 5 Occupant Classification Sensor (Rear RH)



# G ELECTRICAL WIRING ROUTING

□ : Location of Connector Joining Wire Harness and Wire Harness

▽ : Location of Ground Points

[2GR-FE]

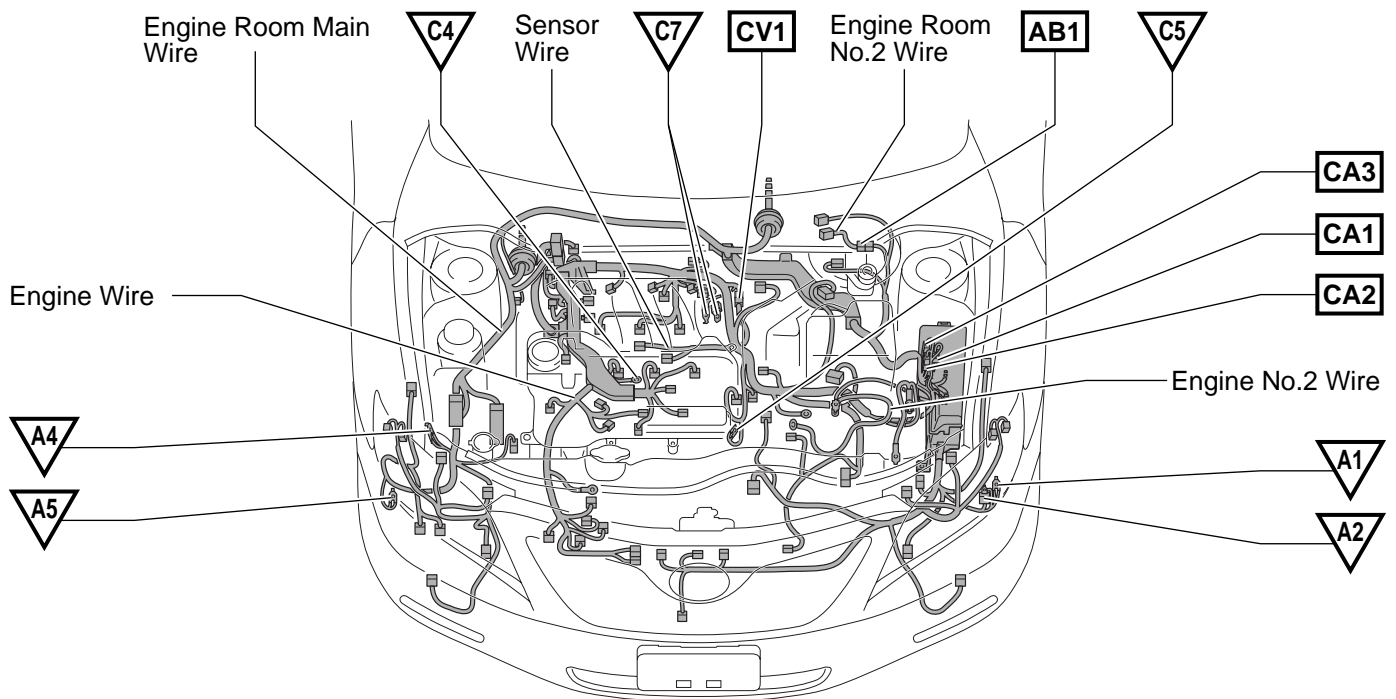

□ : Location of Connector Joining Wire Harness and Wire Harness  
▽ : Location of Ground Points

[2AZ-FE]

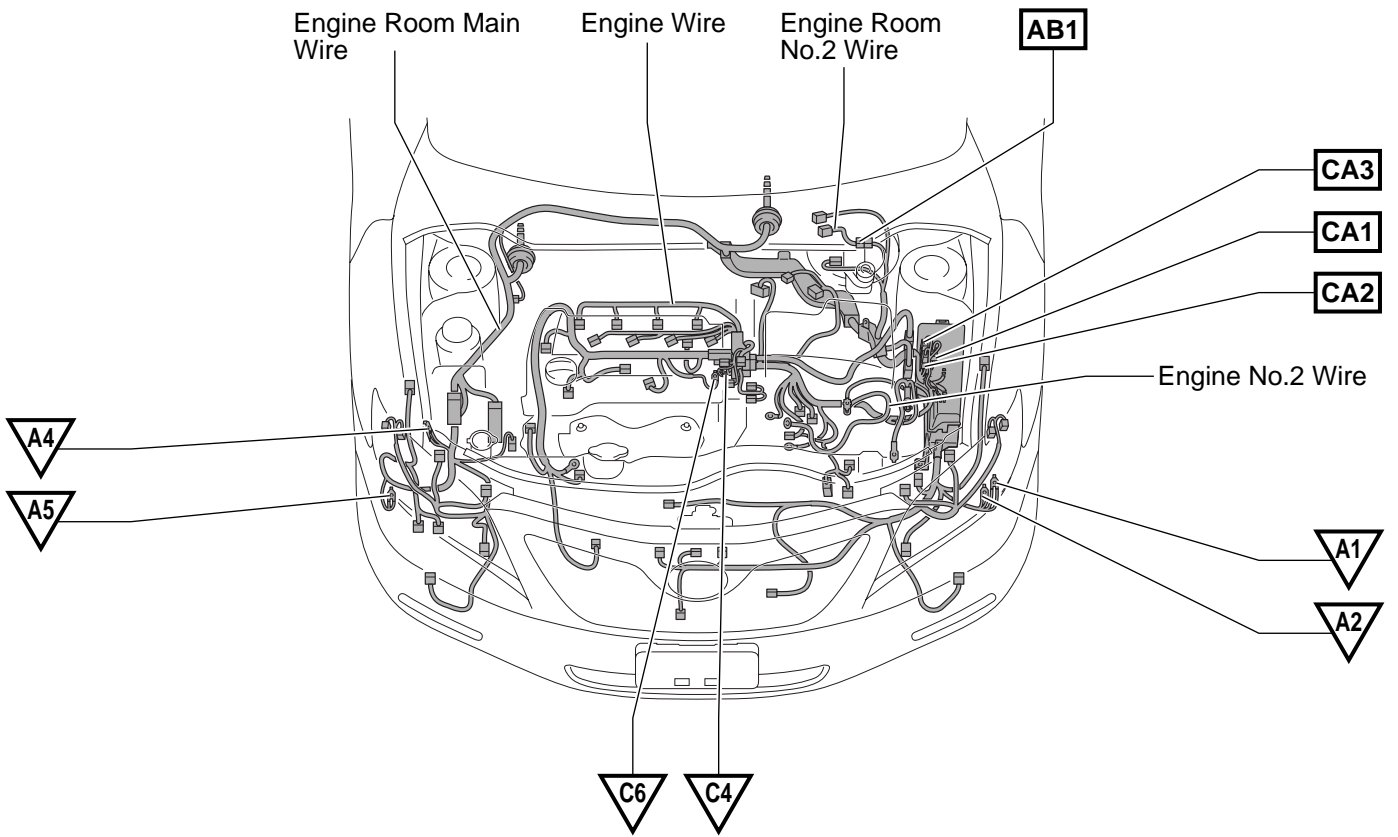

# G ELECTRICAL WIRING ROUTING

□ : Location of Connector Joining Wire Harness and Wire Harness

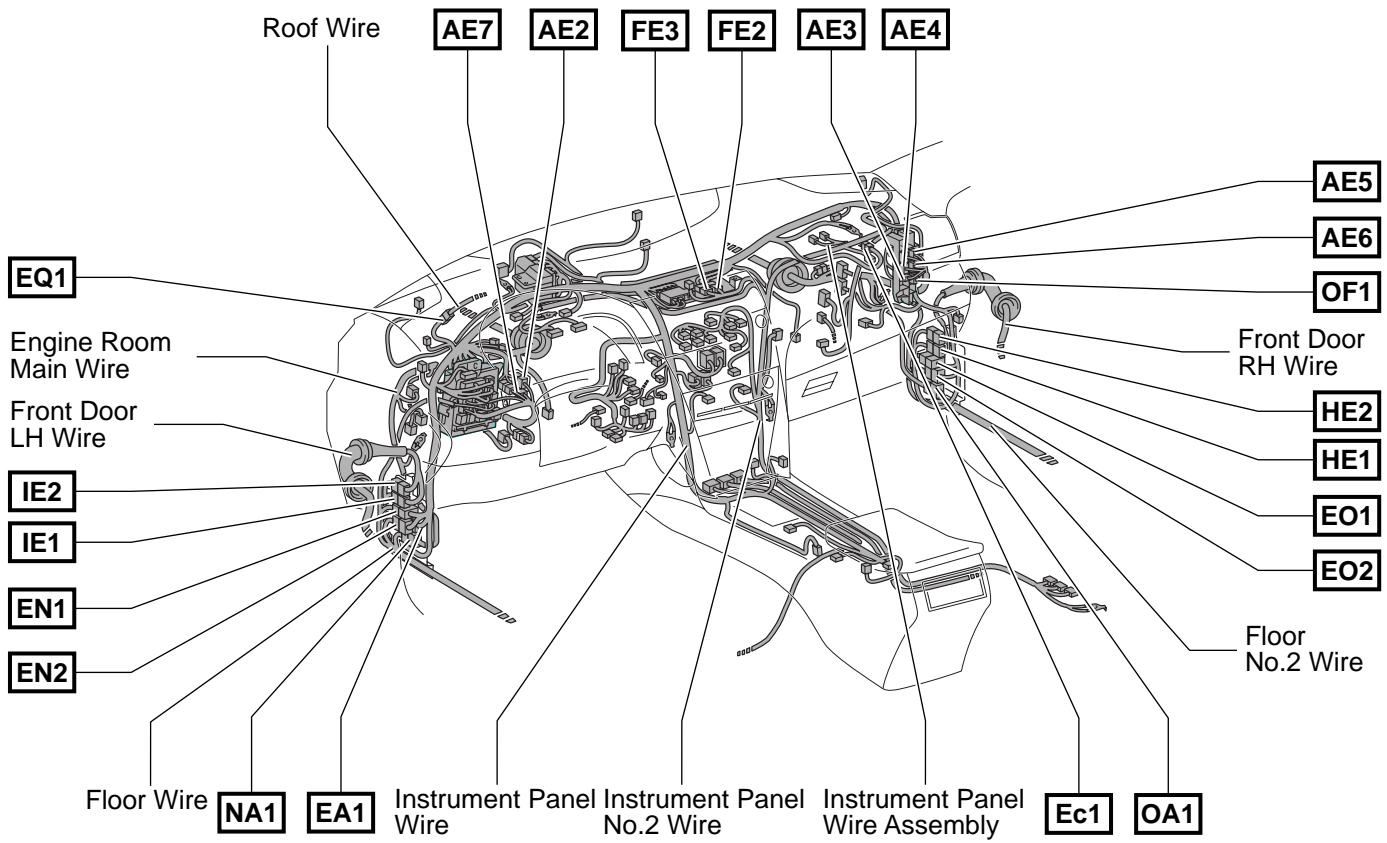

▽ : Location of Ground Points

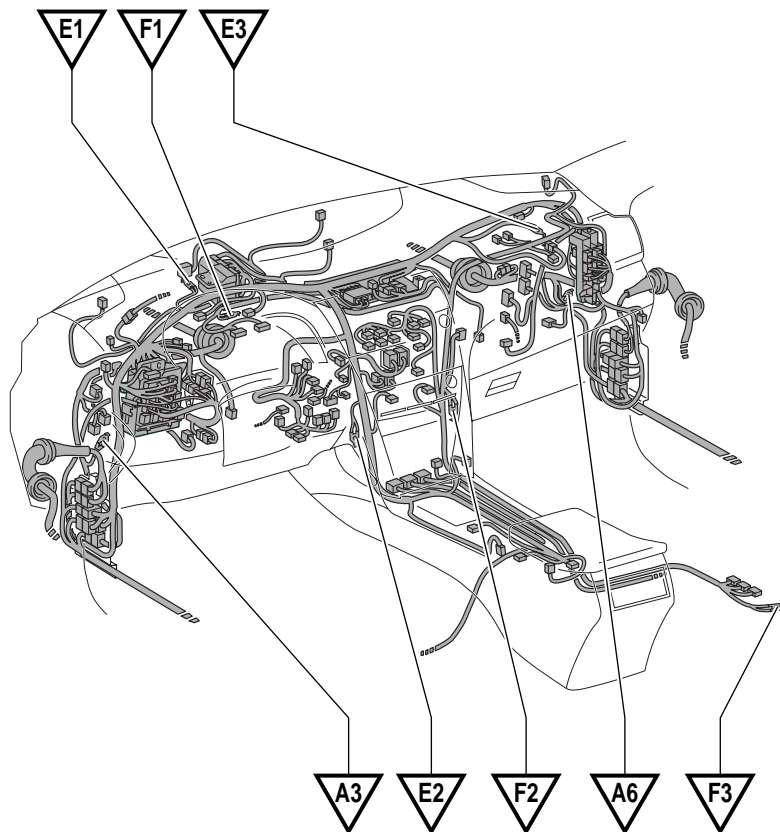

|   |   |
|---|---|
| □ | : Location of Connector Joining Wire Harness and Wire Harness |
| ▽ | : Location of Ground Points                                   |

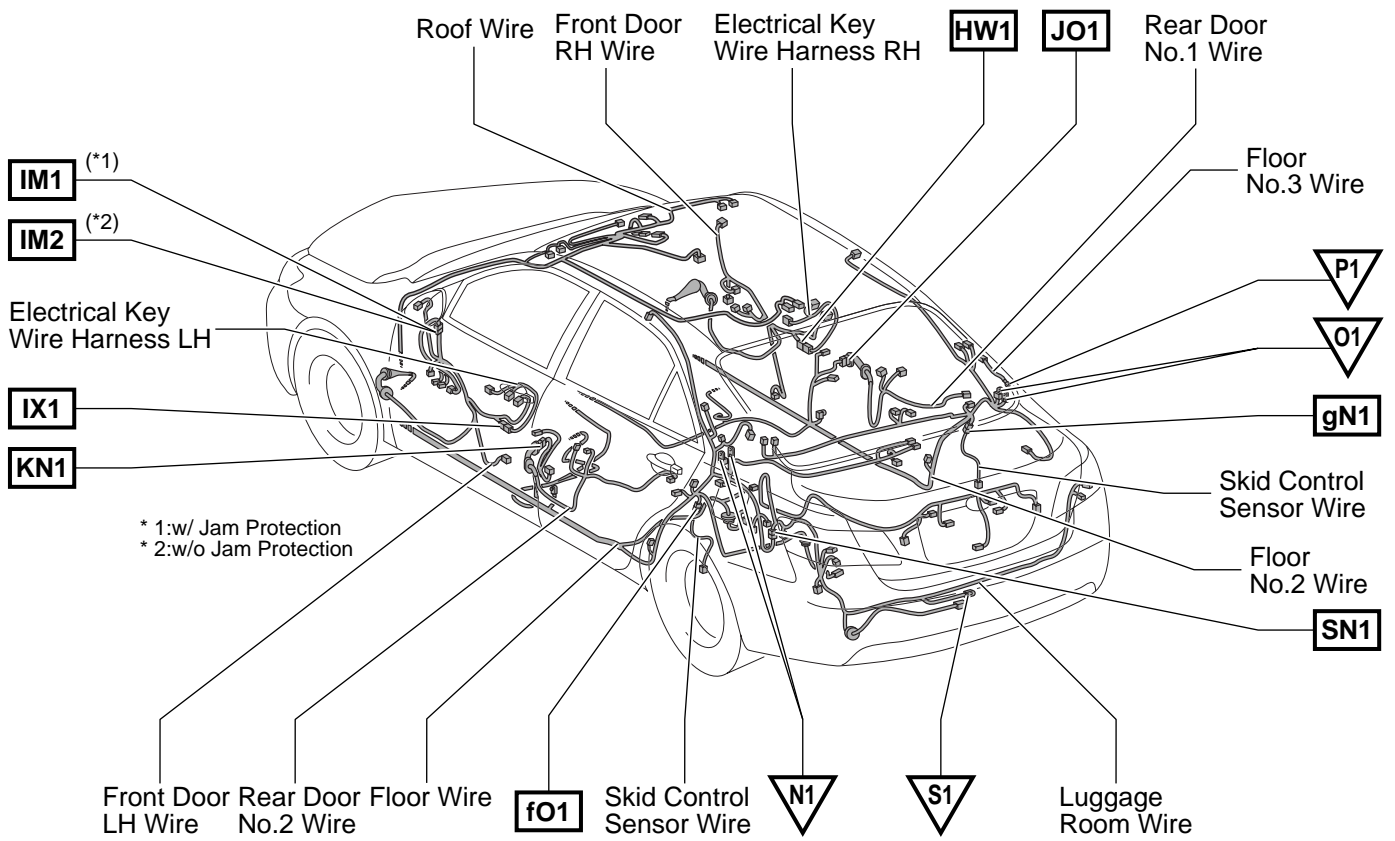

## G ELECTRICAL WIRING ROUTING

**□** : Location of Connector Joining Wire Harness and Wire Harness

[w/ Power Seat]

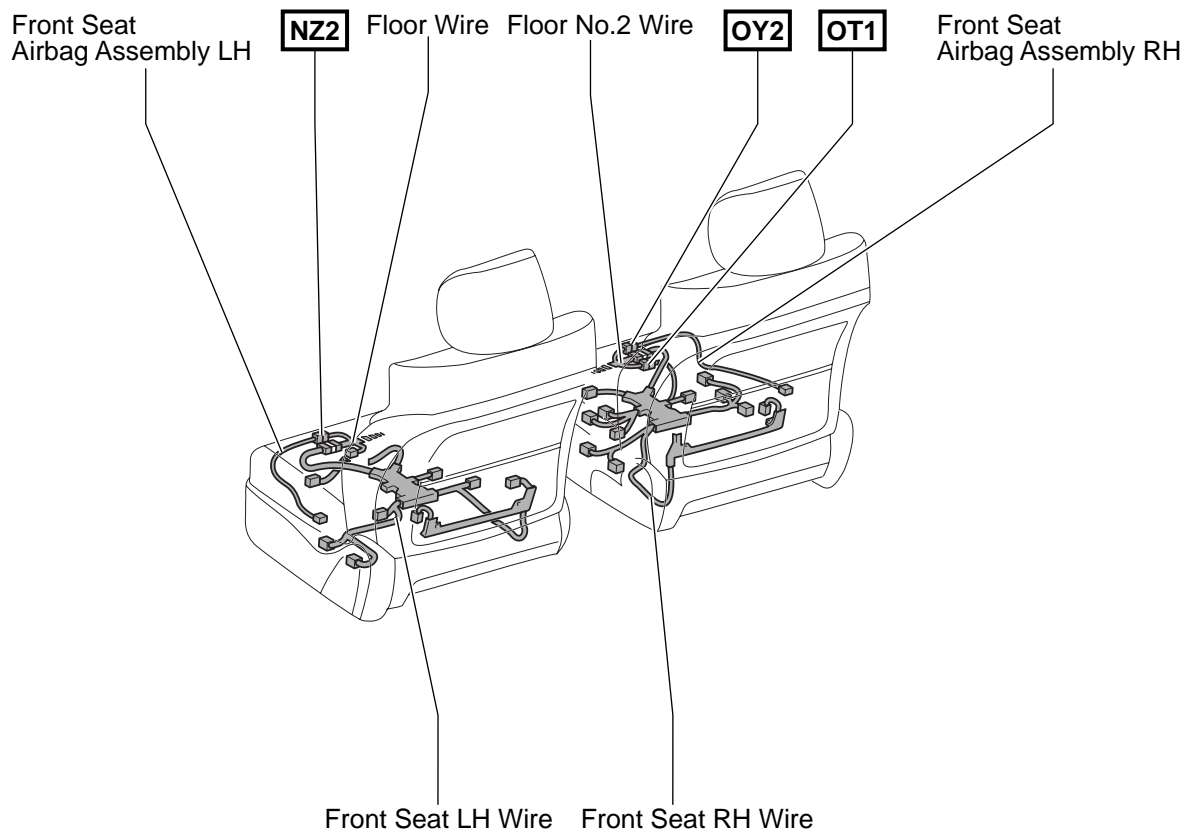

**□ : Location of Connector Joining Wire Harness and Wire Harness**  
**[w/o Power Seat]**

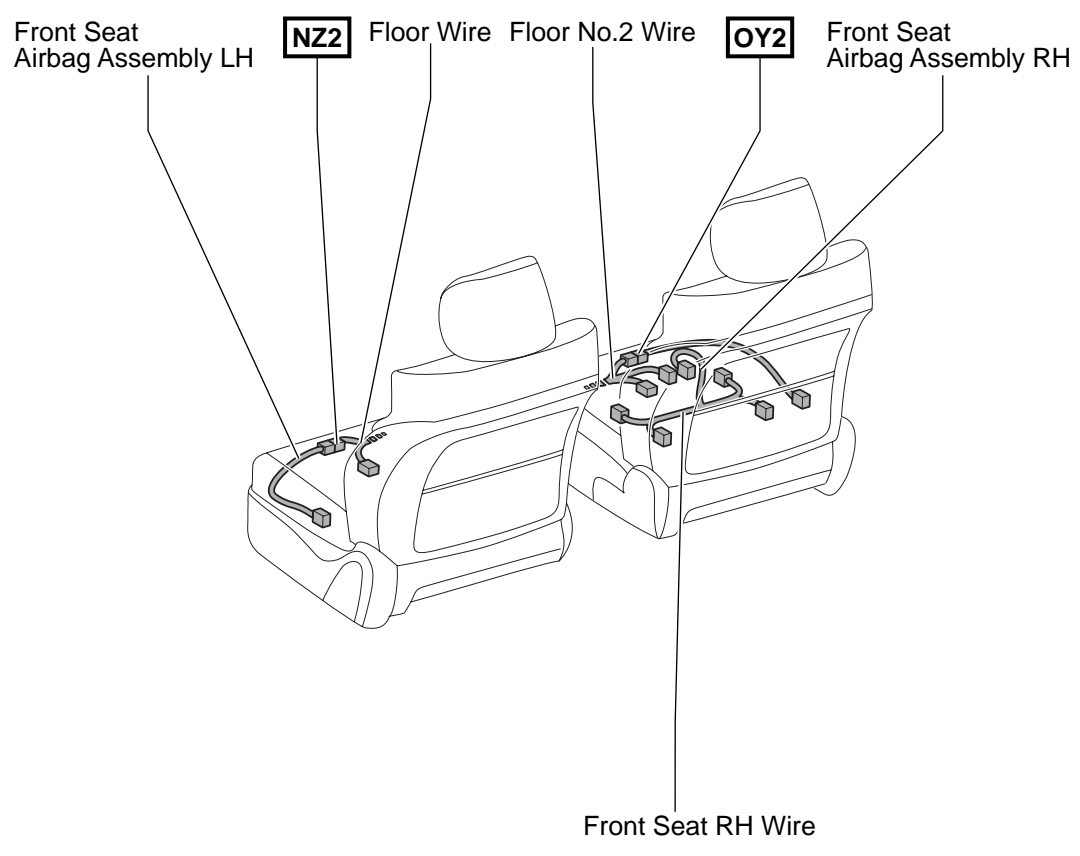

# 2007 CAMRY ELECTRICAL WIRING DIAGRAM SYSTEM CIRCUITS

|   | Page |
|---|------|
| ABS (w/ VSC TMC Made) .....   | 242  |
| ABS (w/ VSC TMMK Made) .....  | 252  |
| ABS (w/o VSC) .....   | 262  |
| Air Conditioning .....  | 386  |
| Audio System (6 Speaker) .....  | 360  |
| Audio System (8 Speaker w/ Navigation System) .....                     | 346  |
| Audio System (8 Speaker w/o Navigation System) .....                    | 354  |
| Automatic Glare-Resistant EC Mirror .....                               | 338  |
| Automatic Light Control .....   | 160  |
| Back-Up Light .....   | 188  |
| Charging .....  | 100  |
| Clock .....   | 202  |
| Combination Meter .....   | 364  |
| Cooling Fan (2GR-FE) .....  | 374  |
| Cruise Control (2AZ-FE) .....   | 292  |
| Cruise Control (2GR-FE) .....   | 282  |
| Data Link Connector 3 .....   | 140  |
| Door Lock Control .....   | 214  |
| Electronically Controlled Transmission and A/T Indicator (2AZ-FE) ..... | 312  |
| Electronically Controlled Transmission and A/T Indicator (2GR-FE) ..... | 300  |
| Engine Control (2AZ-FE) .....   | 126  |
| Engine Control (2GR-FE) .....   | 108  |
| Engine Immobiliser System (w/o Smart Key System) .....                  | 138  |
| Fog Light .....   | 150  |
| Garage Door Opener .....  | 336  |
| Headlight .....   | 144  |
| Horn .....  | 204  |
| Ignition (2AZ-FE) .....   | 106  |
| Ignition (2GR-FE) .....   | 102  |
| Illumination .....  | 172  |
| Interior Light .....  | 164  |
| Key Reminder (w/o Smart Key System) .....                               | 190  |
| Light Auto Turn Off System .....  | 160  |
| Luggage Compartment Door Opener .....                                   | 214  |
| Mirror Heater .....   | 342  |
| Multiplex Communication System (CAN) .....                              | 156  |
| Navigation System .....   | 346  |
| Power Outlet .....  | 200  |
| Power Seat (Driver's Seat) .....  | 322  |
| Power Seat (Front Passenger's Seat) .....                               | 326  |
| Power Source .....  | 72   |
| Power Window .....  | 206  |
| Radiator Fan and Condenser Fan (2AZ-FE) .....                           | 380  |
| Rear Window Defogger .....  | 342  |
| Remote Control Mirror .....   | 340  |
| Seat Belt Warning .....   | 190  |
| Seat Heater .....   | 328  |

|   | Page |
|---|------|
| Shift Lock .....  | 320  |
| Sliding Roof .....                                      | 330  |
| Smart Key System .....                                  | 78   |
| * Engine Immobiliser                                    |      |
| * Push Button Start System                              |      |
| * Steering Lock   |      |
| * Wireless Door Lock Control                            |      |
| SRS .....   | 273  |
| Starting (w/o Smart Key System) .....                   | 96   |
| Stop Light .....  | 186  |
| Taillight .....   | 172  |
| Theft Deterrent .....                                   | 230  |
| Tire Pressure Warning System .....                      | 270  |
| TRAC (TMC Made) .....                                   | 242  |
| TRAC (TMMK Made) .....                                  | 252  |
| Turn Signal and Hazard Warning Light .....              | 182  |
| VSC (TMC Made) .....                                    | 242  |
| VSC (TMMK Made) .....                                   | 252  |
| Wiper and Washer .....                                  | 196  |
| Wireless Door Lock Control (w/o Smart Key System) ..... | 224  |



# Power Source

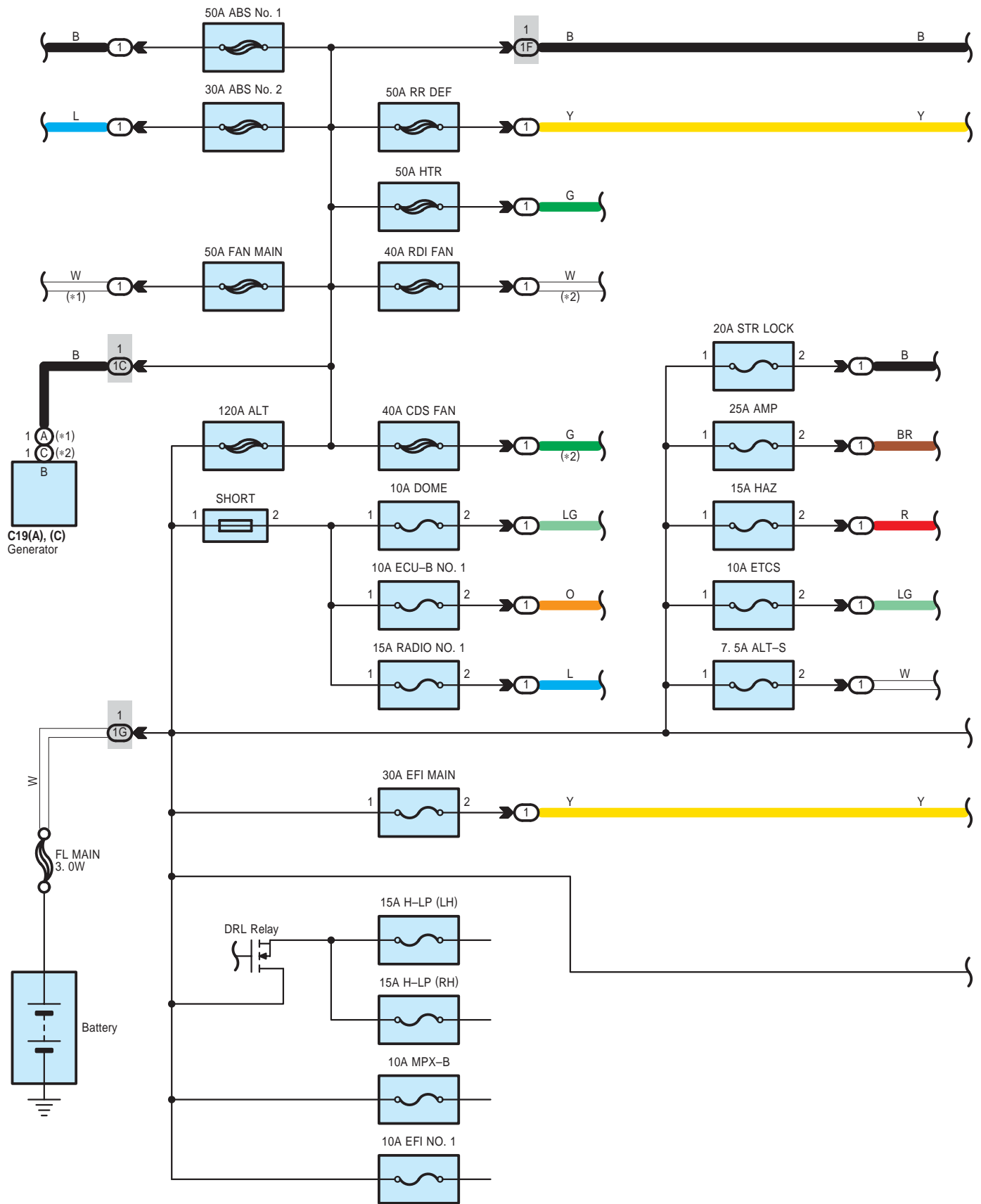

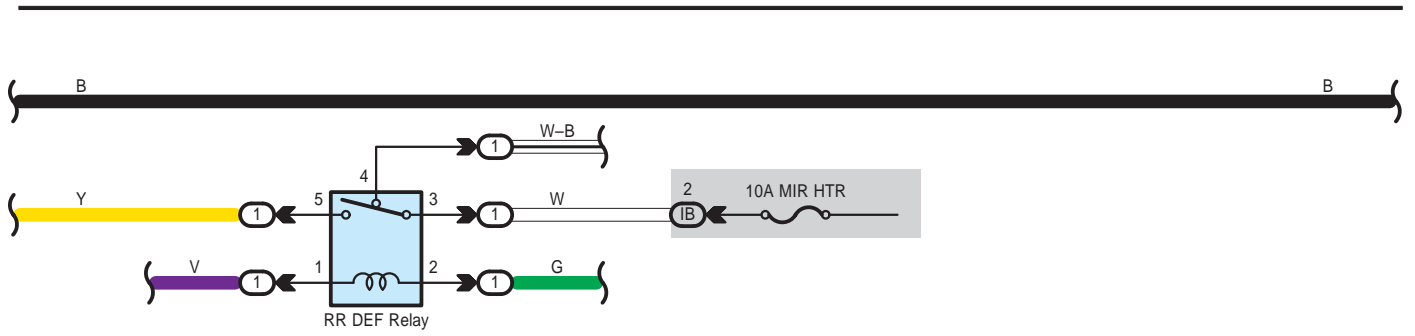

- \* 1 : 2GR-FE
- \* 2 : 2AZ-FE
- \* 3 : w/ Smart Key System
- \* 4 : w/o Smart Key System

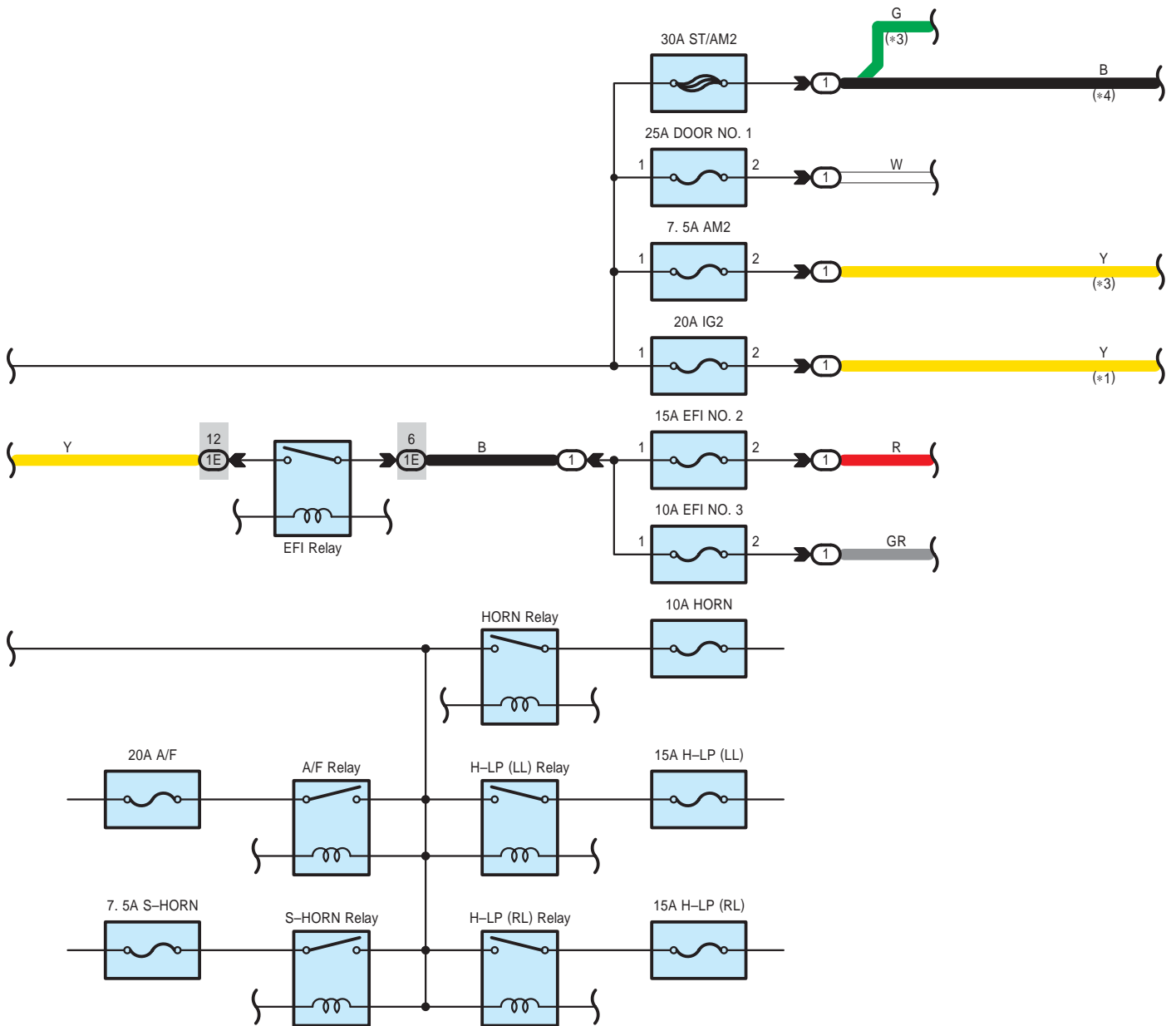

# Power Source

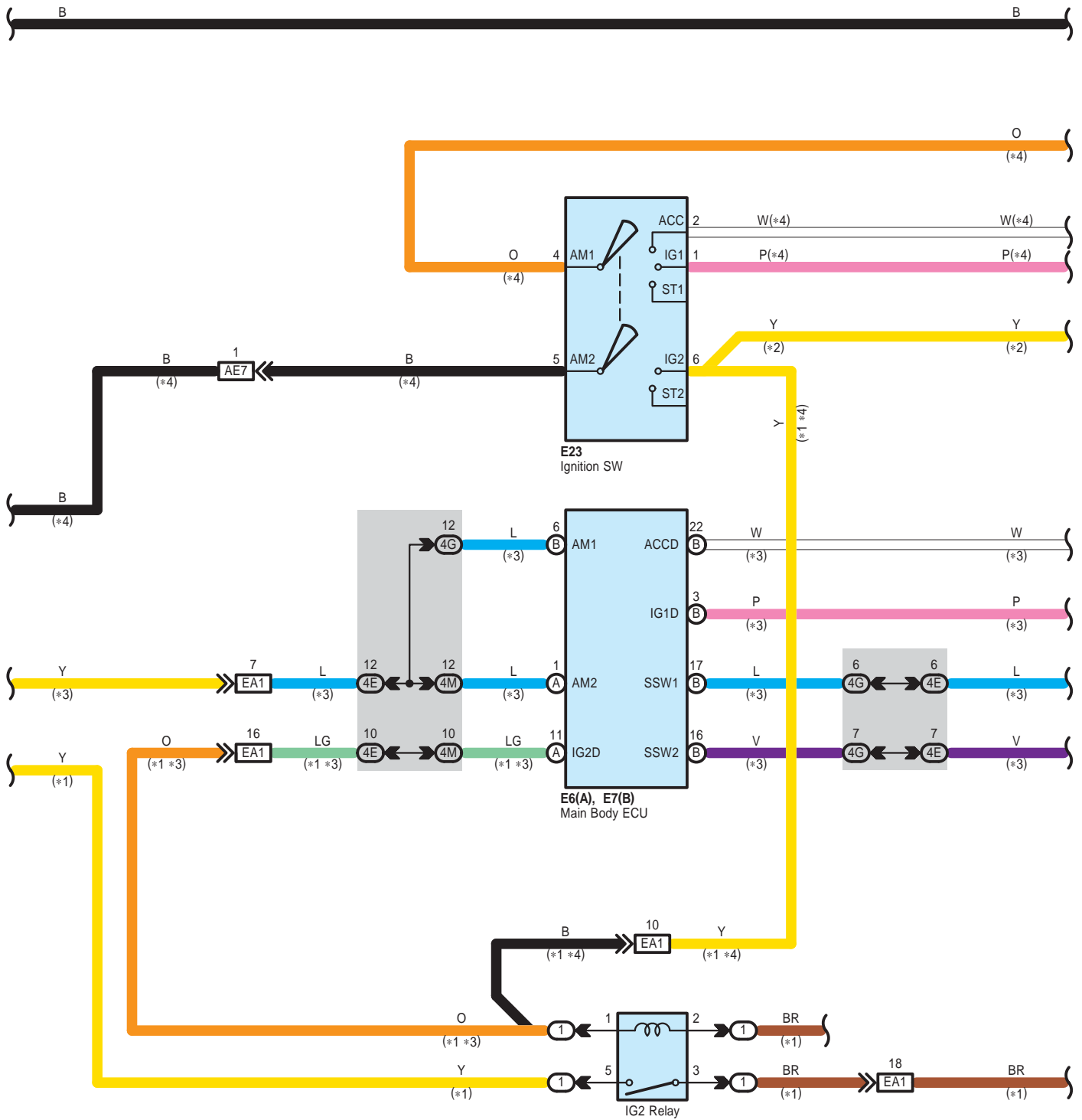

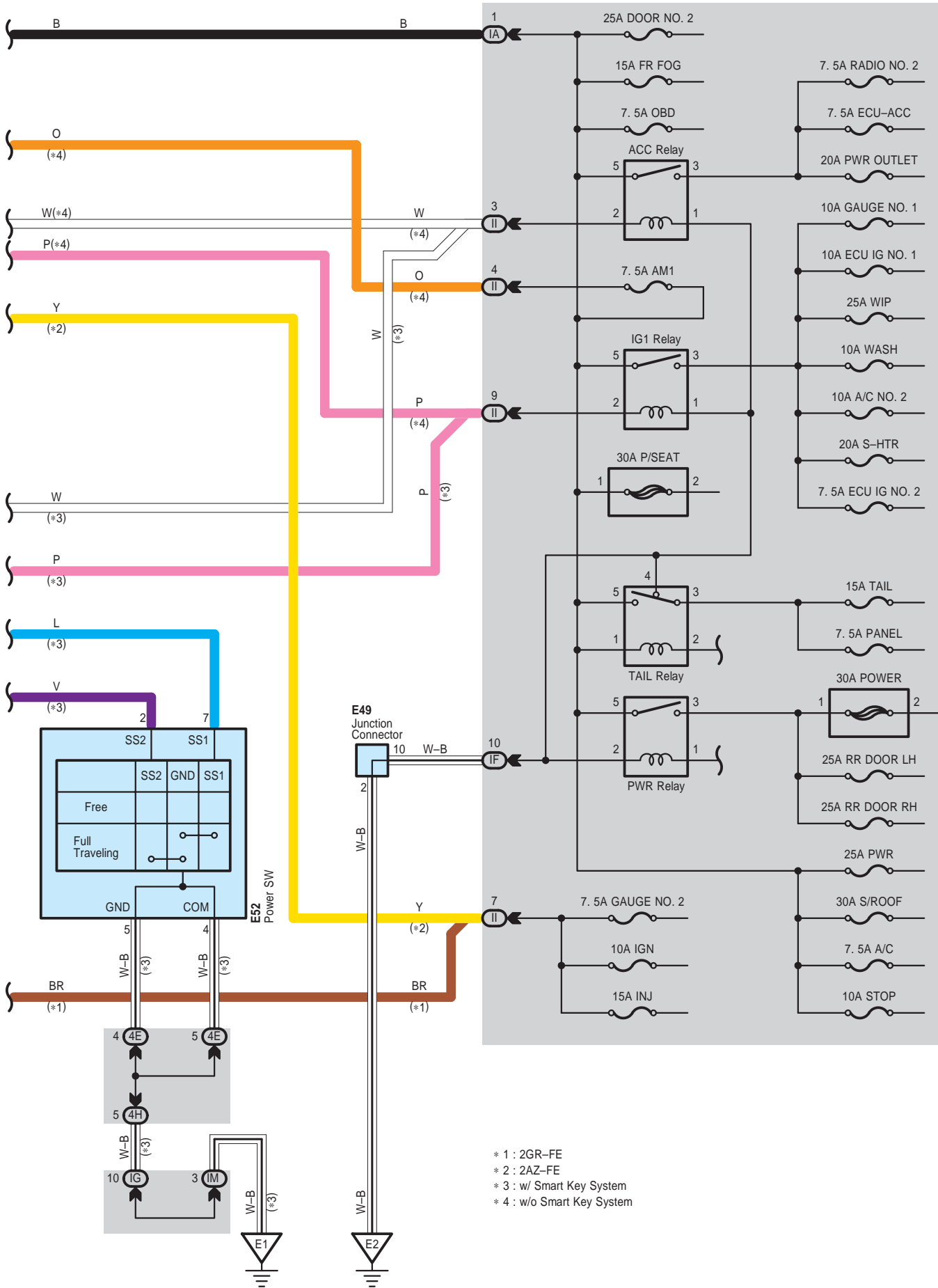

- \* 1 : 2GR-FE
- \* 2 : 2AZ-FE
- \* 3 : w/ Smart Key System
- \* 4 : w/o Smart Key System

# Power Source

## ○ : Parts Location

| Code |   | See Page    | Code |     | See Page | Code |  | See Page |
|------|---|-------------|------|-----|----------|------|--|----------|
| C19  | A | 50 (2GR-FE) | E7   | B   | 56       | E52  |  | 57       |
|      | C | 54 (2AZ-FE) |      | E23 | 56       |      |  |          |
| E6   | A | 56          |      | E49 | 57       |      |  |          |

## ○ : Relay Blocks

| Code | See Page | Relay Blocks (Relay Block Location)       |
|------|----------|---|
| 1    | 22       | Engine Room R/B (Engine Compartment Left) |

## ○ : Junction Block and Wire Harness Connector

| Code | See Page | Junction Block and Wire Harness (Connector Location)                |
|------|----------|---|
| 1C   | 22       | Engine Wire and Engine Room J/B (Engine Compartment Left)           |
| 1E   | 25       | Engine Room Main Wire and Engine Room J/B (Engine Compartment Left) |
| 1F   | 22       |   |
| 1G   |          |   |
| 4E   |          |   |
| 4G   | 42       | Instrument Panel Wire and J/B No.4 (Instrument Panel Brace Center)  |
| 4H   |          |   |
| 4M   |          |   |
| IA   | 30       |   |
| IB   |          |   |
| IF   | 30       | Instrument Panel Wire and Instrument Panel J/B (Cowl Side Left)     |
| IG   | 31       |   |
| II   |          |   |
| IM   |          |   |

## □ : Connector Joining Wire Harness and Wire Harness

| Code | See Page | Joining Wire Harness and Wire Harness (Connector Location)                               |
|------|----------|--|
| AE7  | 66       | Engine Room Main Wire and Instrument Panel Wire (Right Side of the Instrument Panel J/B) |
| EA1  | 66       | Instrument Panel Wire and Engine Room Main Wire (Left Kick Panel)                        |

## ▽ : Ground Points

| Code | See Page | Ground Points Location    |
|------|----------|---------------------------|
| E1   | 66       | Instrument Panel Left     |
| E2   | 66       | Instrument Panel Brace LH |



# Smart Key System

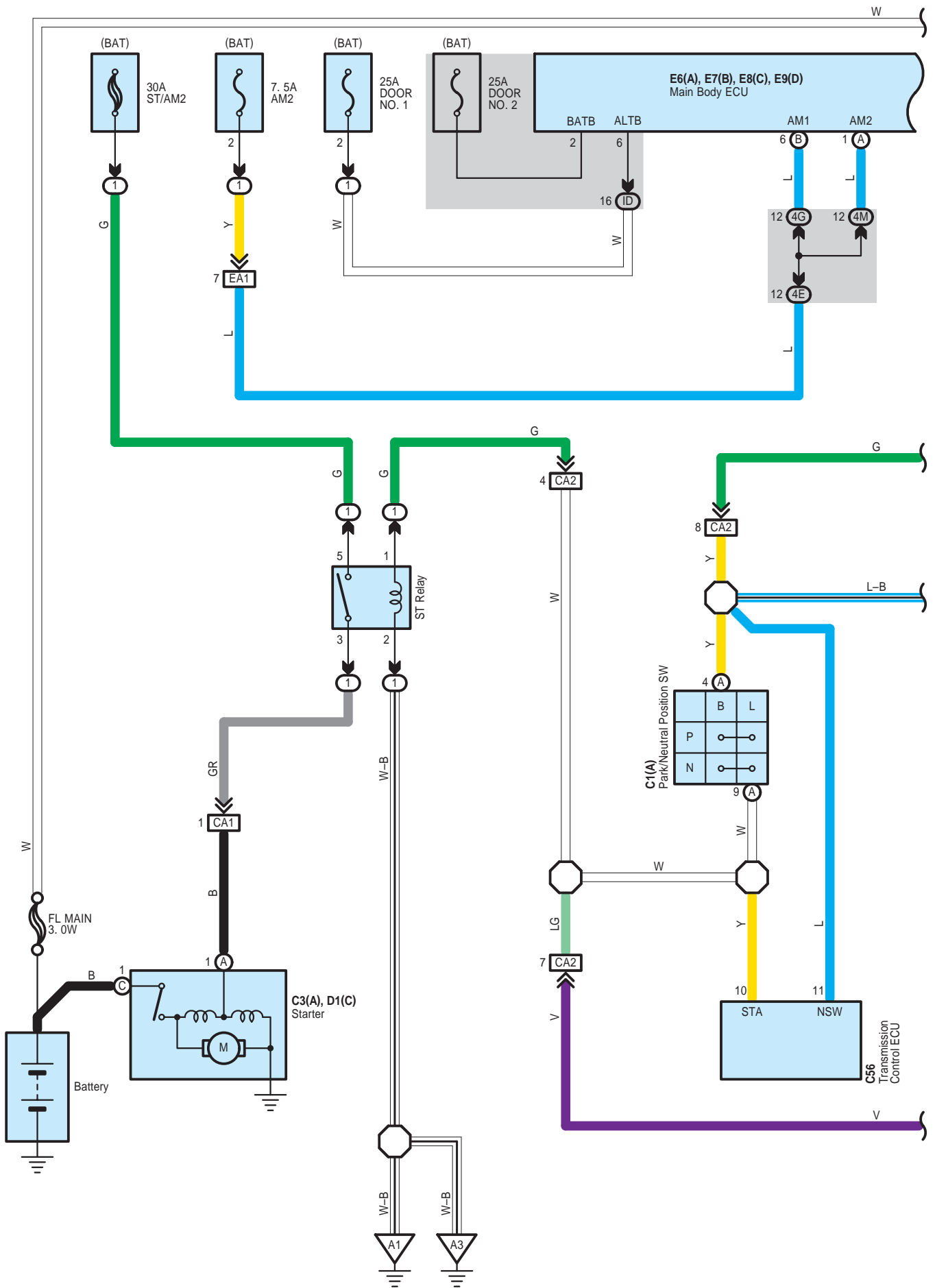

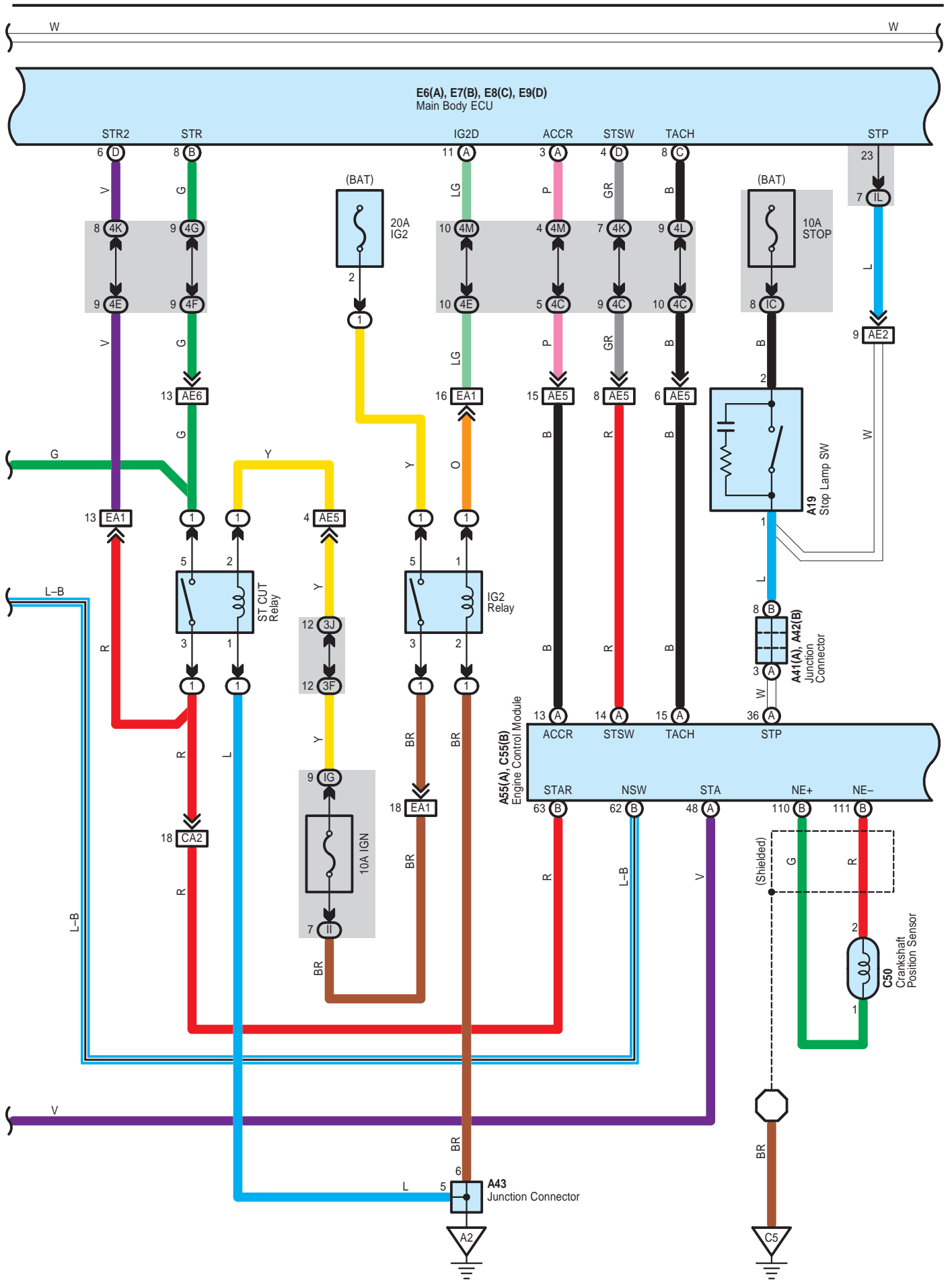

CAMRY (EM0250U)



# Smart Key System

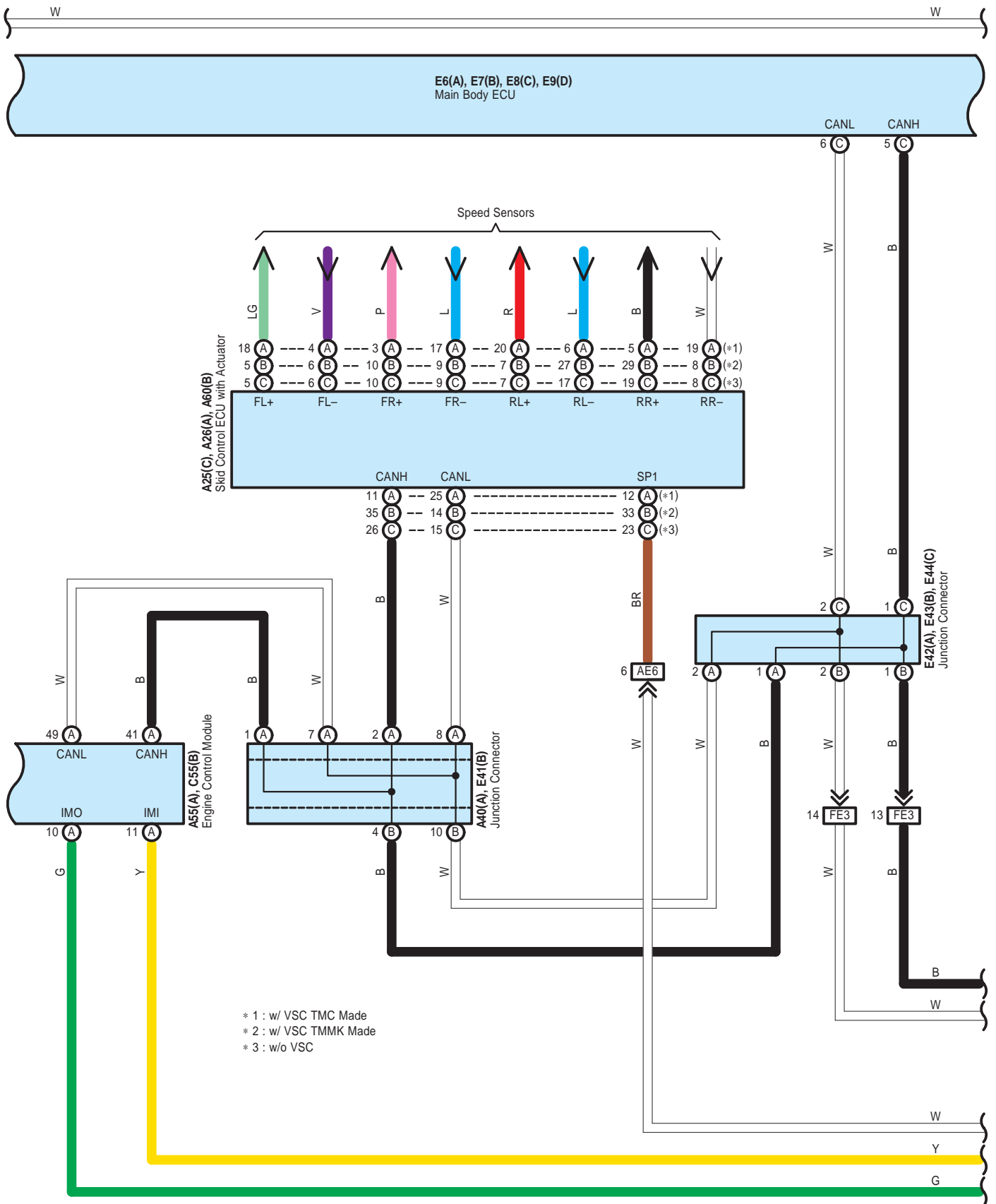

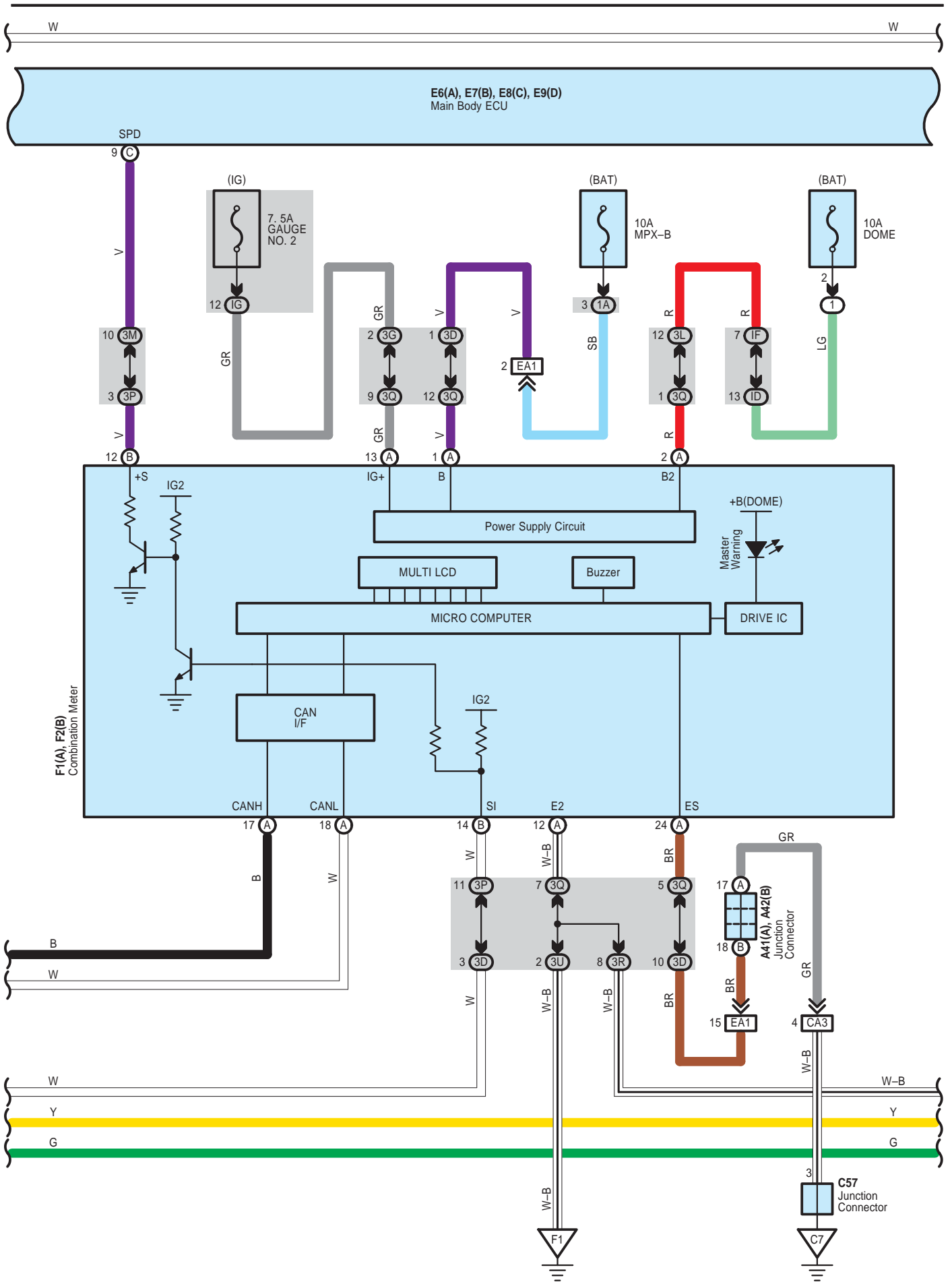

CAMRY (EM0250U)

# Smart Key System

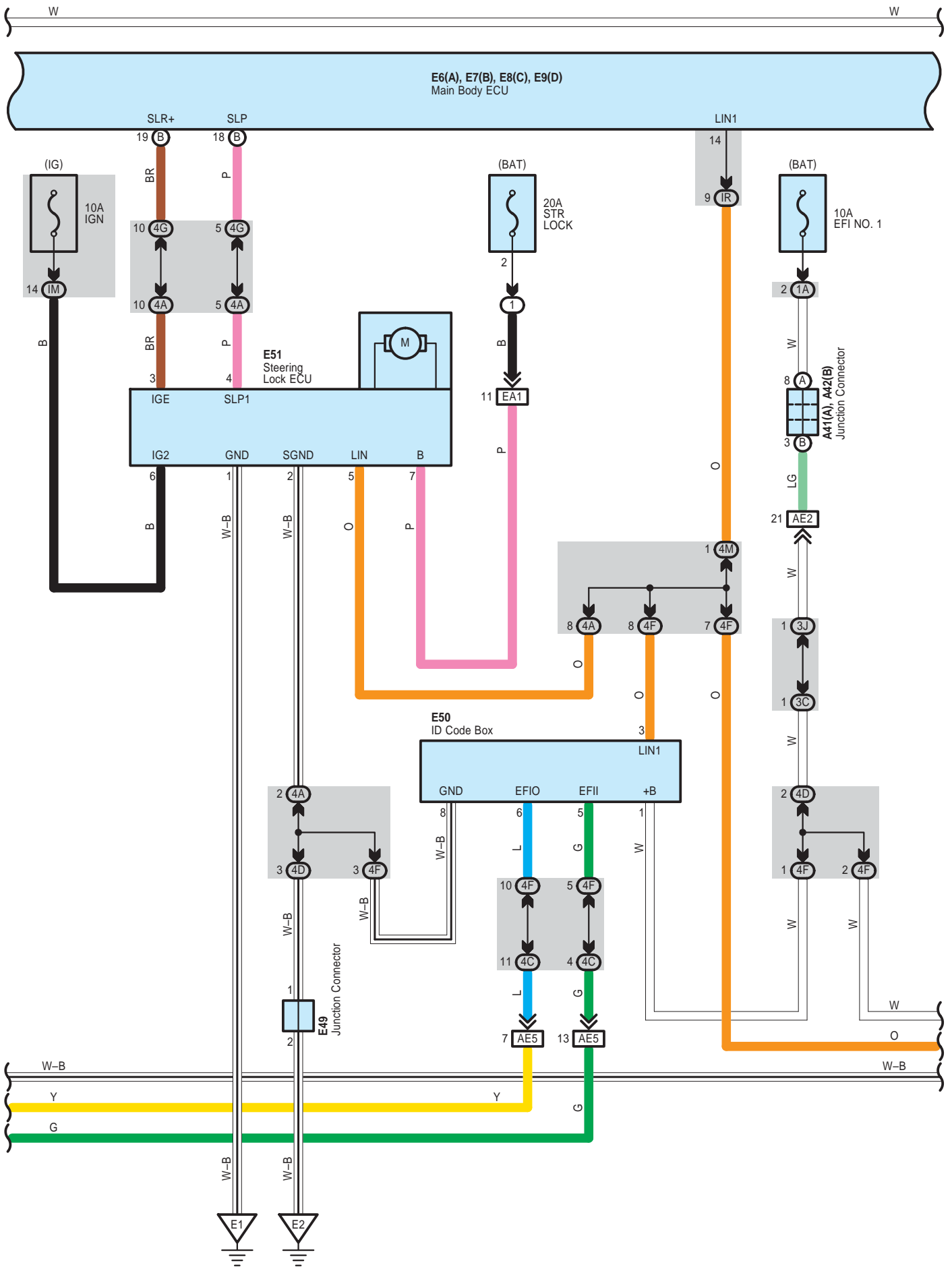

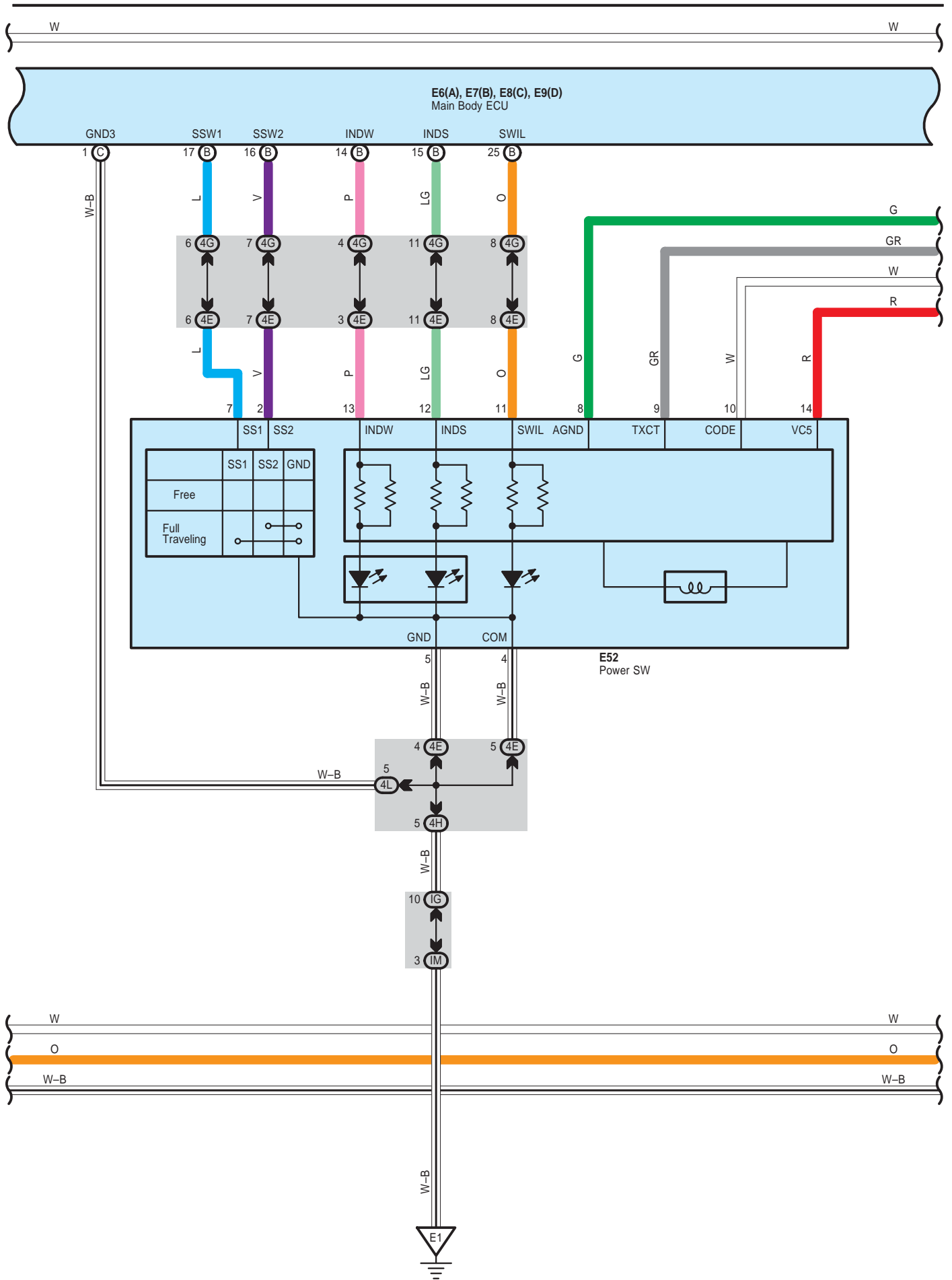

CAMRY (EM0250U)

# Smart Key System

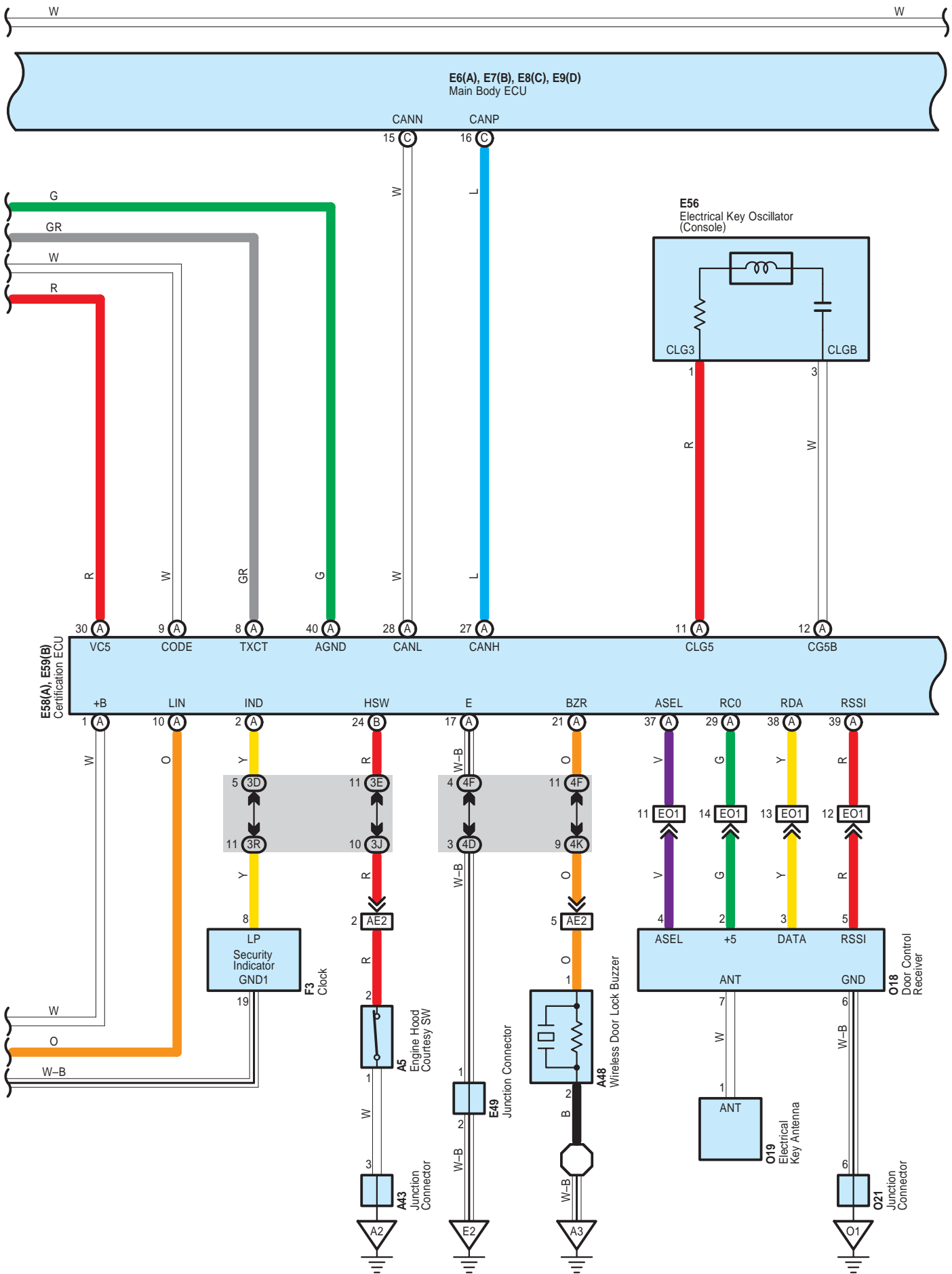

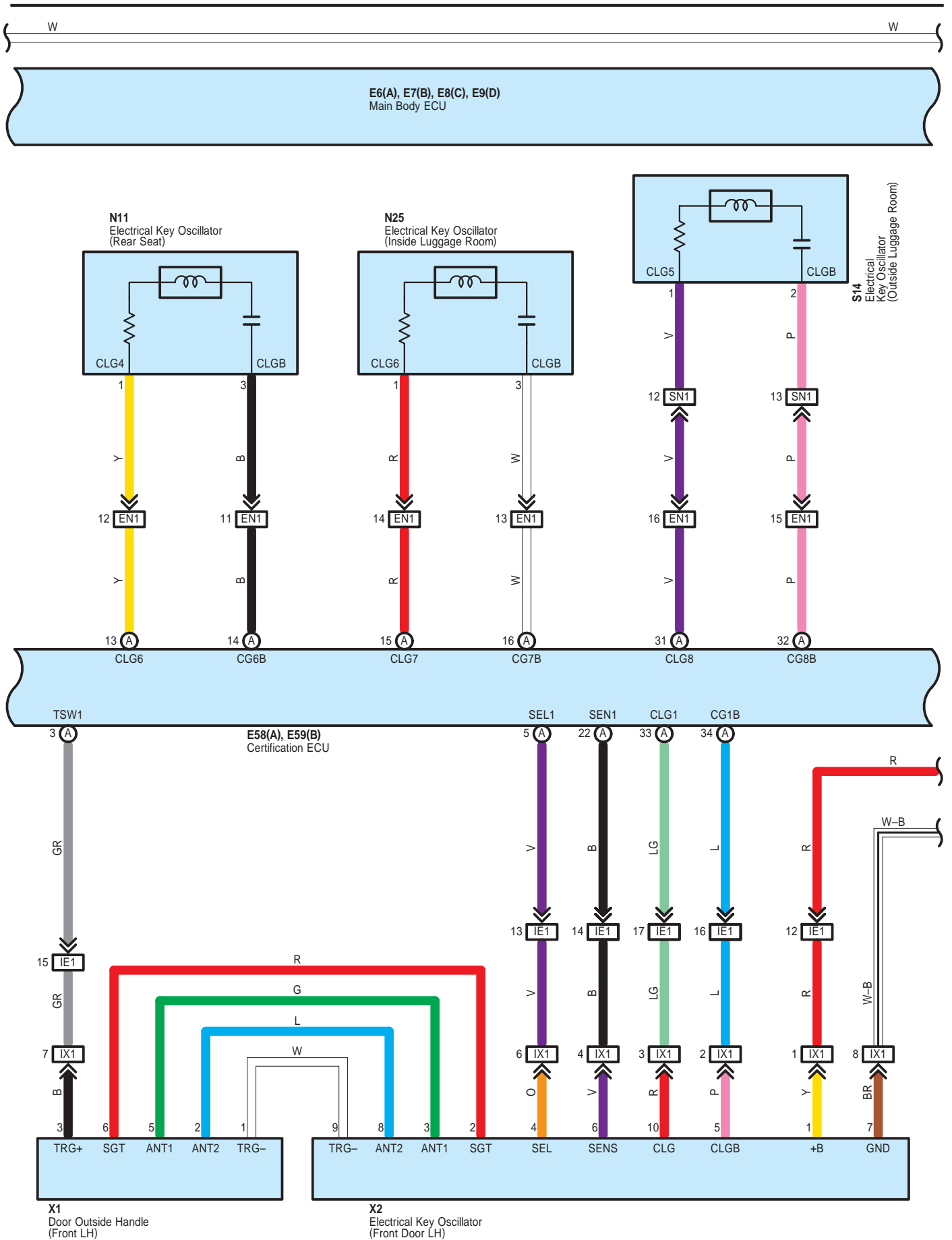

# Smart Key System

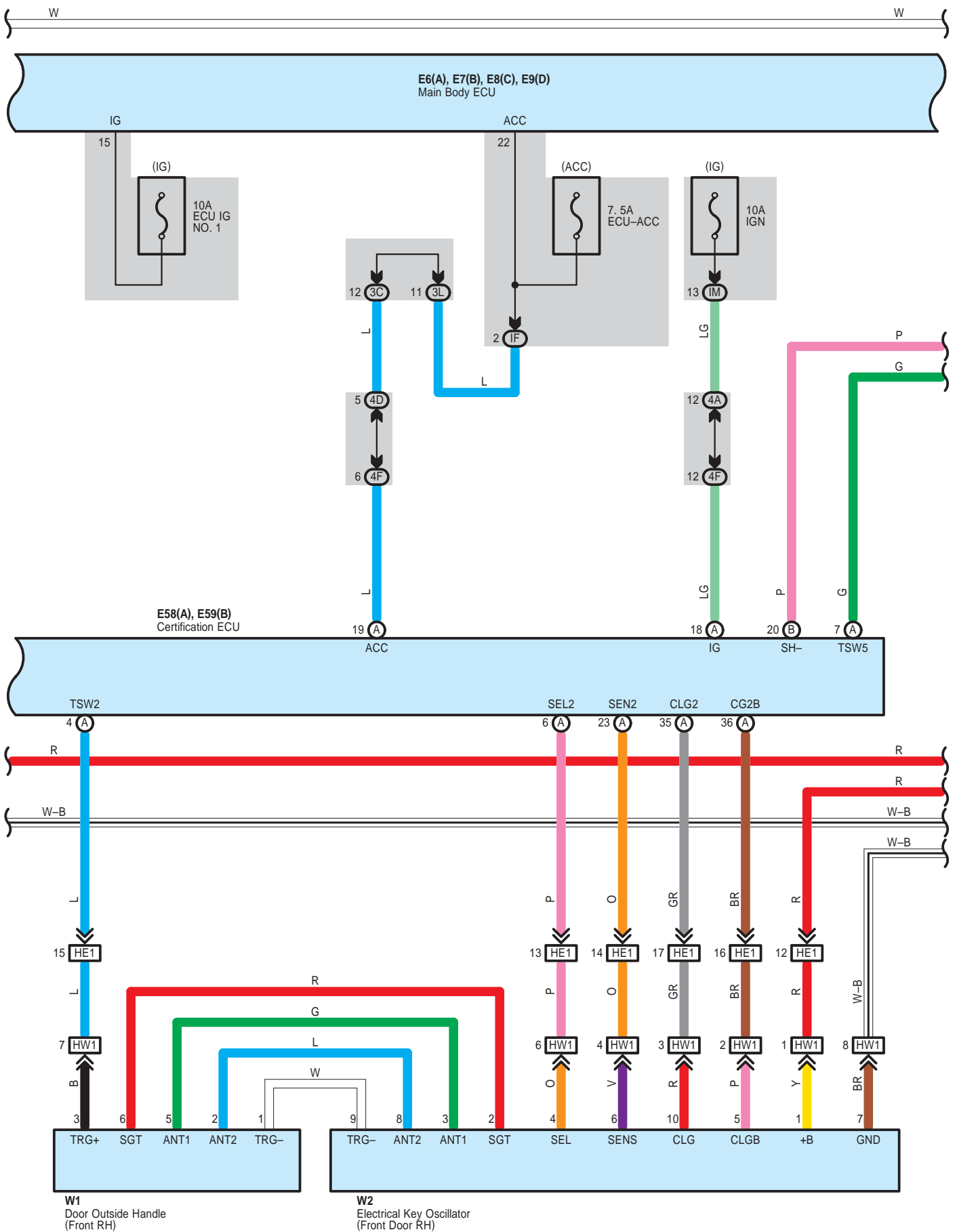

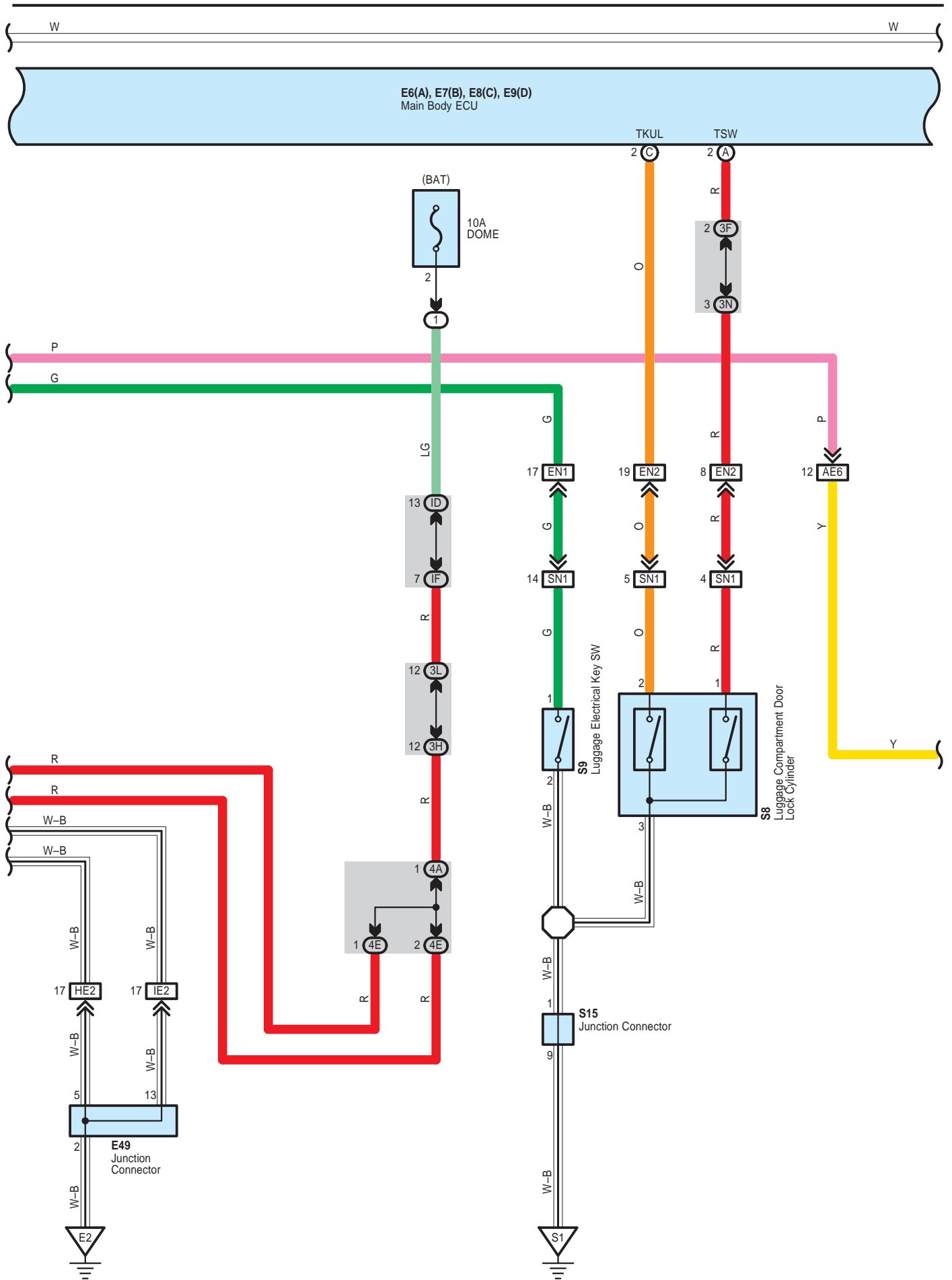

CAMRY (EM0250U)



# Smart Key System

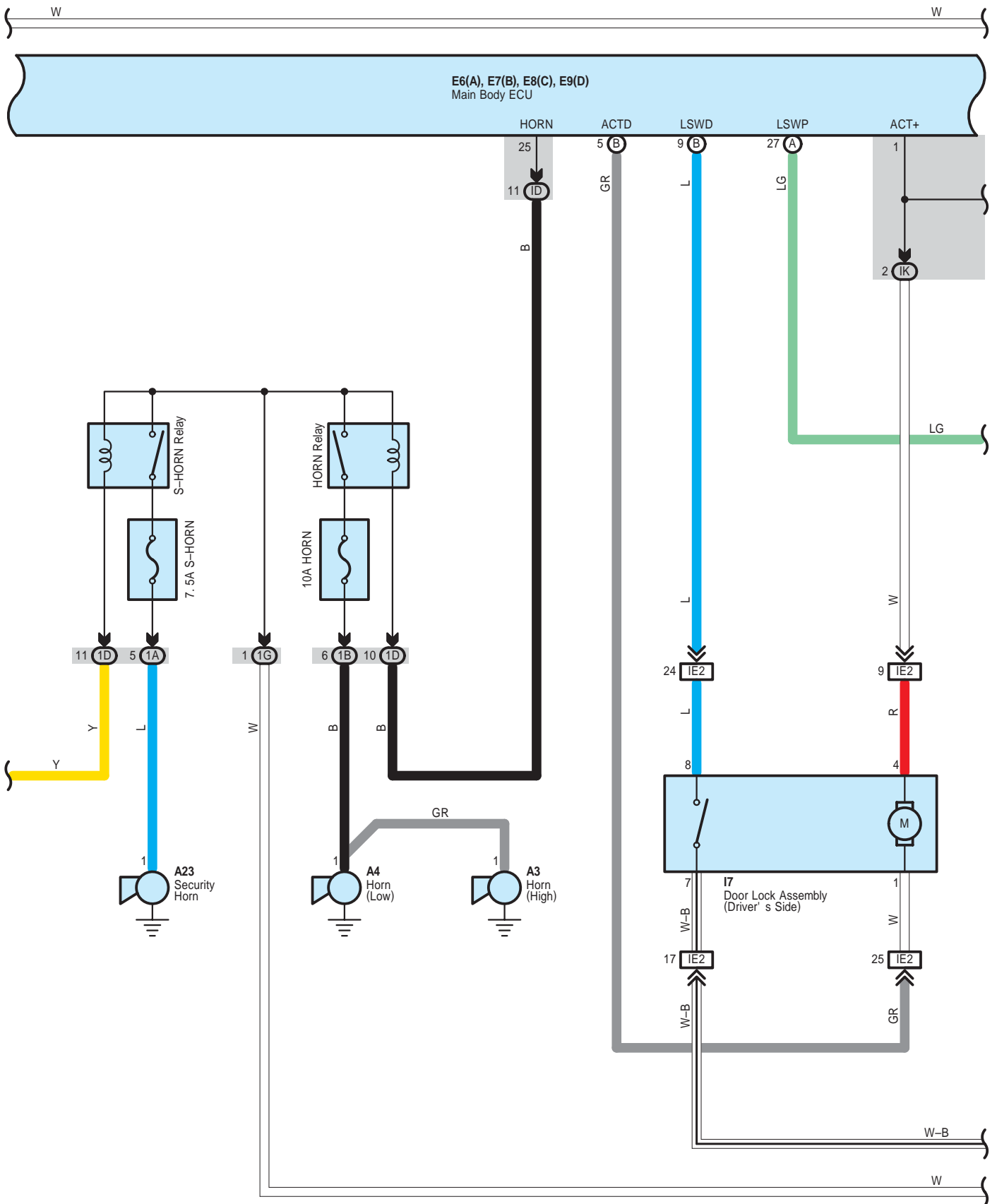

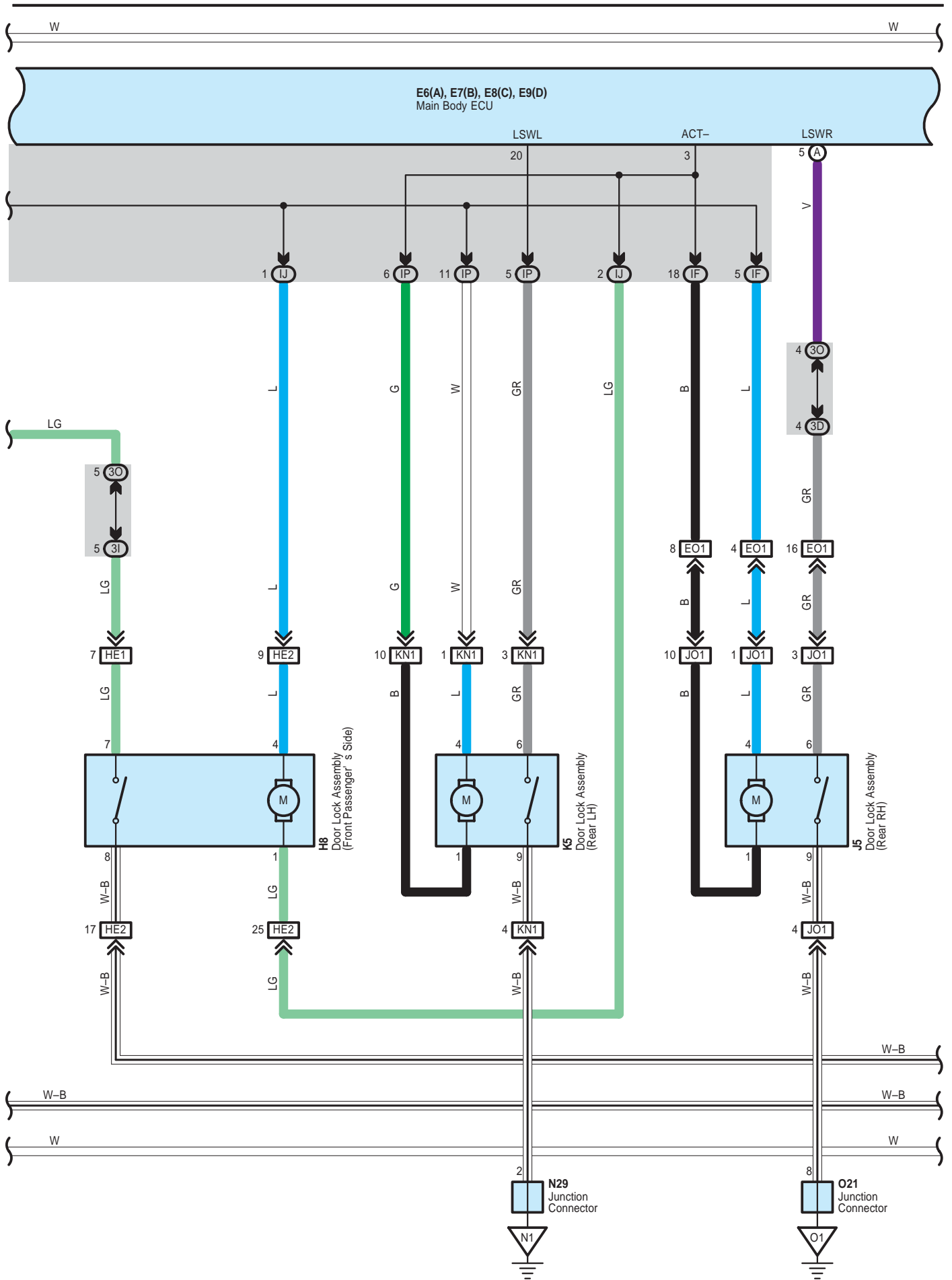

# Smart Key System

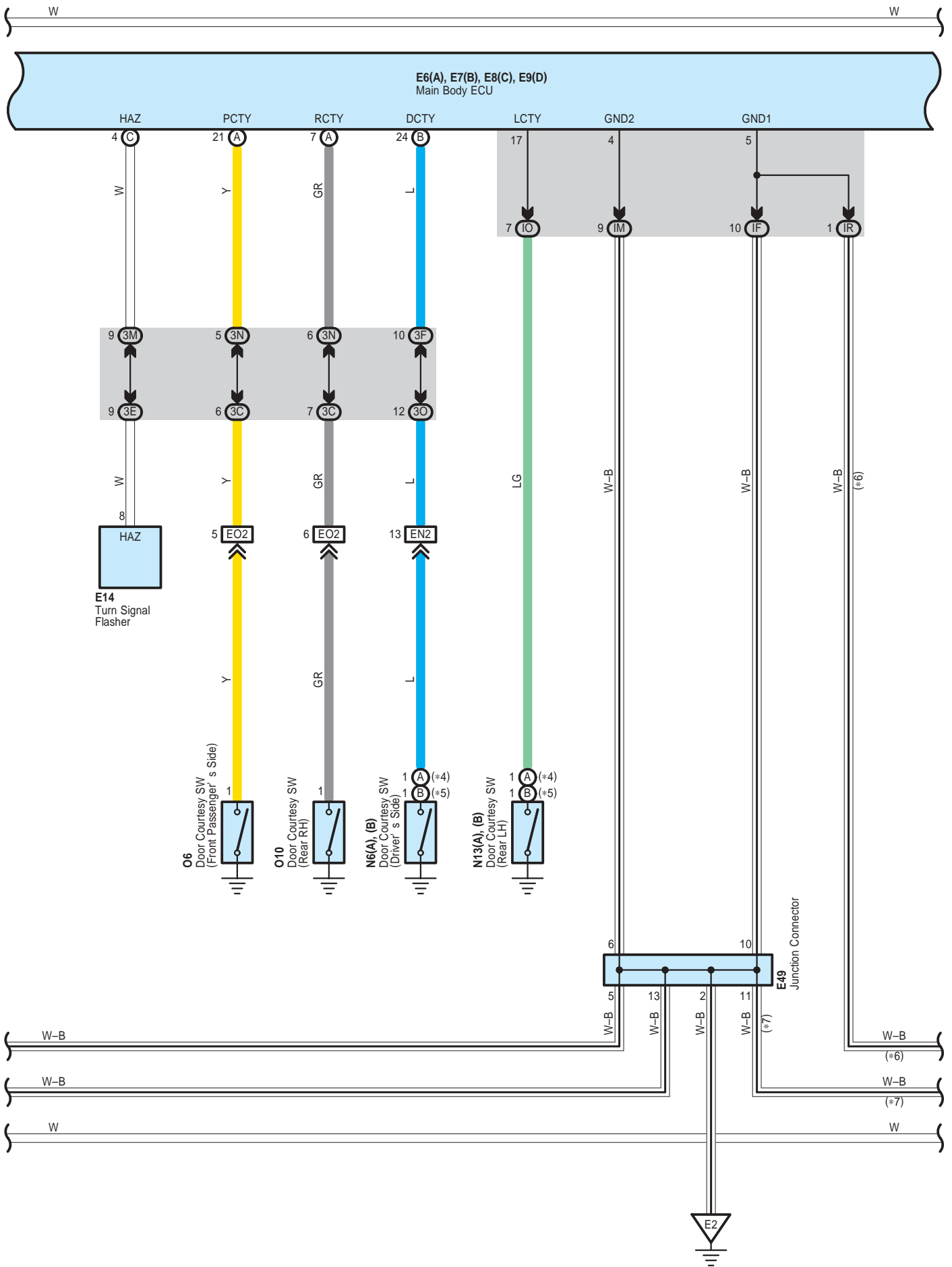

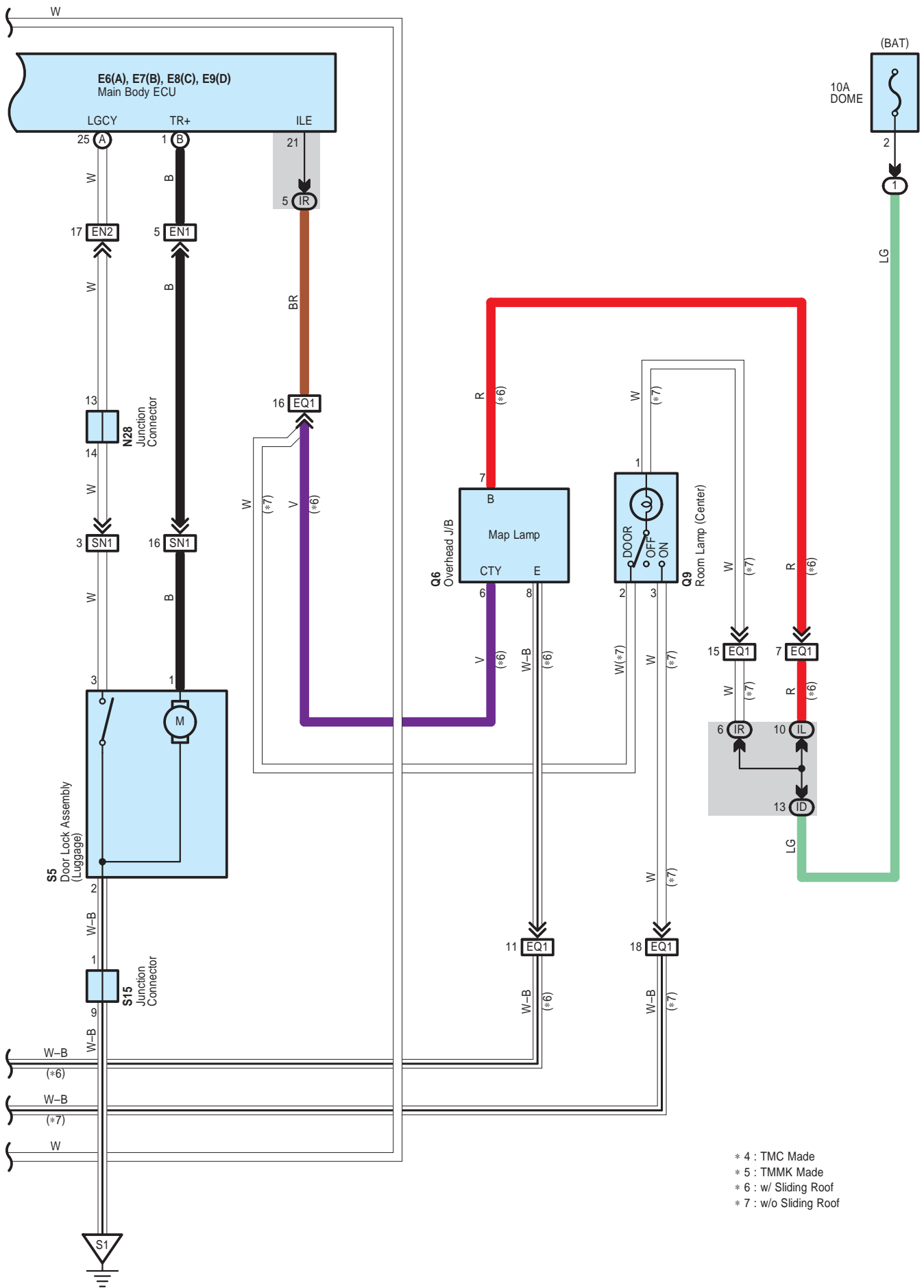

# Smart Key System

## System Outline

### \* Steering lock

Receiving signals from the power SW and the key, the certification ECU sends instruction for locking and unlocking the steering lock to the steering lock ECU (Built in the steering lock) in order to activate the motor. The steering lock ECU detects position of the lock bar and stops the motor at the specified position.

## ○ : Parts Location

| Code | See Page    | Code        | See Page | Code | See Page |     |    |
|------|-------------|-------------|----------|------|----------|-----|----|
| A3   | 48 (2GR-FE) | E8          | C        | 56   | N11      | 60  |    |
| A4   | 48 (2GR-FE) | E9          | D        | 56   | N13      | A   | 60 |
| A5   | 48 (2GR-FE) | E14         |          | 56   |          | B   | 60 |
| A19  | 59          | E41         | B        | 57   | N25      | 60  |    |
| A23  | 48 (2GR-FE) | E42         | A        | 57   | N28      | 60  |    |
| A25  | C           | 48 (2GR-FE) | E43      | B    | 57       | N29 | 60 |
| A26  | A           | 48 (2GR-FE) | E44      | C    | 57       | O6  | 60 |
| A40  | A           | 59          | E49      | 57   | O10      | 60  |    |
| A41  | A           | 59          | E50      | 57   | O18      | 60  |    |
| A42  | B           | 59          | E51      | 57   | O19      | 60  |    |
| A43  | 49 (2GR-FE) | E52         | 57       | O21  | 60       |     |    |
| A48  | 49 (2GR-FE) | E56         | 57       | Q6   | 61       |     |    |
| A55  | A           | 49 (2GR-FE) | E58      | A    | 57       | Q9  | 61 |
| A60  | B           | 49 (2GR-FE) | E59      | B    | 57       | S5  | 61 |
| C1   | A           | 50 (2GR-FE) | F1       | A    | 58       | S8  | 61 |
| C3   | A           | 50 (2GR-FE) | F2       | B    | 58       | S9  | 61 |
| C50  | 51 (2GR-FE) | F3          | 58       | S14  | 61       |     |    |
| C55  | B           | 51 (2GR-FE) | H8       | 61   | S15      | 61  |    |
| C56  | 51 (2GR-FE) | I7          | 61       | W1   | 61       |     |    |
| C57  | 51 (2GR-FE) | J5          | 61       | W2   | 61       |     |    |
| D1   | C           | 51 (2GR-FE) | K5       | 61   | X1       | 61  |    |
| E6   | A           | 56          | N6       | A    | 60       | X2  | 61 |
| E7   | B           | 56          |          | B    | 60       |     |    |

## ○ : Relay Blocks

| Code | See Page | Relay Blocks (Relay Block Location)       |
|------|----------|---|
| 1    | 22       | Engine Room R/B (Engine Compartment Left) |



: Junction Block and Wire Harness Connector

| Code | See Page | Junction Block and Wire Harness (Connector Location)                   |
|------|----------|--|
| 1A   | 25       | Engine Room Main Wire and Engine Room J/B (Engine Compartment Left)    |
| 1B   |          |  |
| 1D   |          |  |
| 1G   |          |  |
| 1G   | 22       |  |
| 3C   | 36       | Instrument Panel Wire and J/B No.3 (Behind the Combination Meter)      |
| 3D   |          |  |
| 3E   |          |  |
| 3F   |          |  |
| 3G   |          |  |
| 3H   |          |  |
| 3I   |          |  |
| 3J   |          |  |
| 3L   |          |  |
| 3M   |          |  |
| 3N   |          |  |
| 3O   |          |  |
| 3P   | 36       | Instrument Panel No.2 Wire and J/B No.3 (Behind the Combination Meter) |
| 3Q   |          |  |
| 3R   |          |  |
| 3U   |          |  |
| 4A   | 42       | Instrument Panel Wire and J/B No.4 (Instrument Panel Brace Center)     |
| 4C   |          |  |
| 4D   |          |  |
| 4E   |          |  |
| 4F   |          |  |
| 4G   |          |  |
| 4H   |          |  |
| 4K   |          |  |
| 4L   |          |  |
| 4M   |          |  |
| IC   | 30       | Engine Room Main Wire and Instrument Panel J/B (Cowl Side Left)        |
| ID   | 30       |  |
| IF   | 30       |  |
| IG   | 31       | Instrument Panel Wire and Instrument Panel J/B (Cowl Side Left)        |
| II   |          |  |
| IJ   | 30       | Instrument Panel Wire and Instrument Panel J/B (Cowl Side Left)        |
| IK   |          |  |
| IL   |          |  |
| IM   |          |  |
| IO   | 30       | Floor Wire and Instrument Panel J/B (Cowl Side Left)                   |
| IP   | 30       |  |
| IR   | 30       | Instrument Panel Wire and Instrument Panel J/B (Cowl Side Left)        |

# Smart Key System

 : Connector Joining Wire Harness and Wire Harness

| Code | See Page    | Joining Wire Harness and Wire Harness (Connector Location)                                |
|------|-------------|---|
| AE2  | 66          | Engine Room Main Wire and Instrument Panel Wire (Right Side of the Instrument Panel J/B)  |
| AE5  | 66          | Engine Room Main Wire and Instrument Panel Wire (Instrument Panel Right)                  |
| AE6  |             |   |
| CA1  | 64 (2GR-FE) | Engine Wire and Engine Room Main Wire (Inside of the Engine Room R/B and Engine Room J/B) |
| CA2  |             |   |
| CA3  |             |   |
| EA1  | 66          | Instrument Panel Wire and Engine Room Main Wire (Left Kick Panel)                         |
| EN1  | 66          | Instrument Panel Wire and Floor Wire (Left Kick Panel)                                    |
| EN2  |             |   |
| EO1  | 66          | Instrument Panel Wire and Floor No.2 Wire (Right Kick Panel)                              |
| EO2  |             |   |
| EQ1  | 66          | Instrument Panel Wire and Roof Wire (Lower Part of Front Pillar LH)                       |
| FE3  | 66          | Instrument Panel No.2 Wire and Instrument Panel Wire (Instrument Panel Center)            |
| HE1  | 66          | Front Door RH Wire and Instrument Panel Wire (Right Kick Panel)                           |
| HE2  |             |   |
| HW1  | 67          | Front Door RH Wire and Electrical Key Wire Harness RH (Inside of the Front Door RH)       |
| IE1  | 66          | Front Door LH Wire and Instrument Panel Wire (Left Kick Panel)                            |
| IE2  |             |   |
| IX1  | 67          | Front Door LH Wire and Electrical Key Wire Harness LH (Inside of the Front Door LH)       |
| JO1  | 67          | Rear Door No.1 Wire and Floor No.2 Wire (Right Center Pillar)                             |
| KN1  | 67          | Rear Door No.2 Wire and Floor Wire (Left Center Pillar)                                   |
| SN1  | 67          | Luggage Room Wire and Floor Wire (Luggage Room Left)                                      |

 : Ground Points

| Code | See Page    | Ground Points Location           |
|------|-------------|----------------------------------|
| A1   | 64 (2GR-FE) | Front Left Fender                |
| A2   |             |                                  |
| A3   | 66          | Left Cowl Side Panel             |
| C5   | 64 (2GR-FE) | Right Side of the Cylinder Block |
| C7   | 64 (2GR-FE) | Left Side of the Cylinder Block  |
| E1   | 66          | Instrument Panel Left            |
| E2   | 66          | Instrument Panel Brace LH        |
| F1   | 66          | Instrument Panel Left            |
| N1   | 67          | Left Rear Quarter Panel          |
| O1   | 67          | Right Rear Quarter Panel         |
| S1   | 67          | Lower Back Panel Center          |





# Starting without Smart Key System

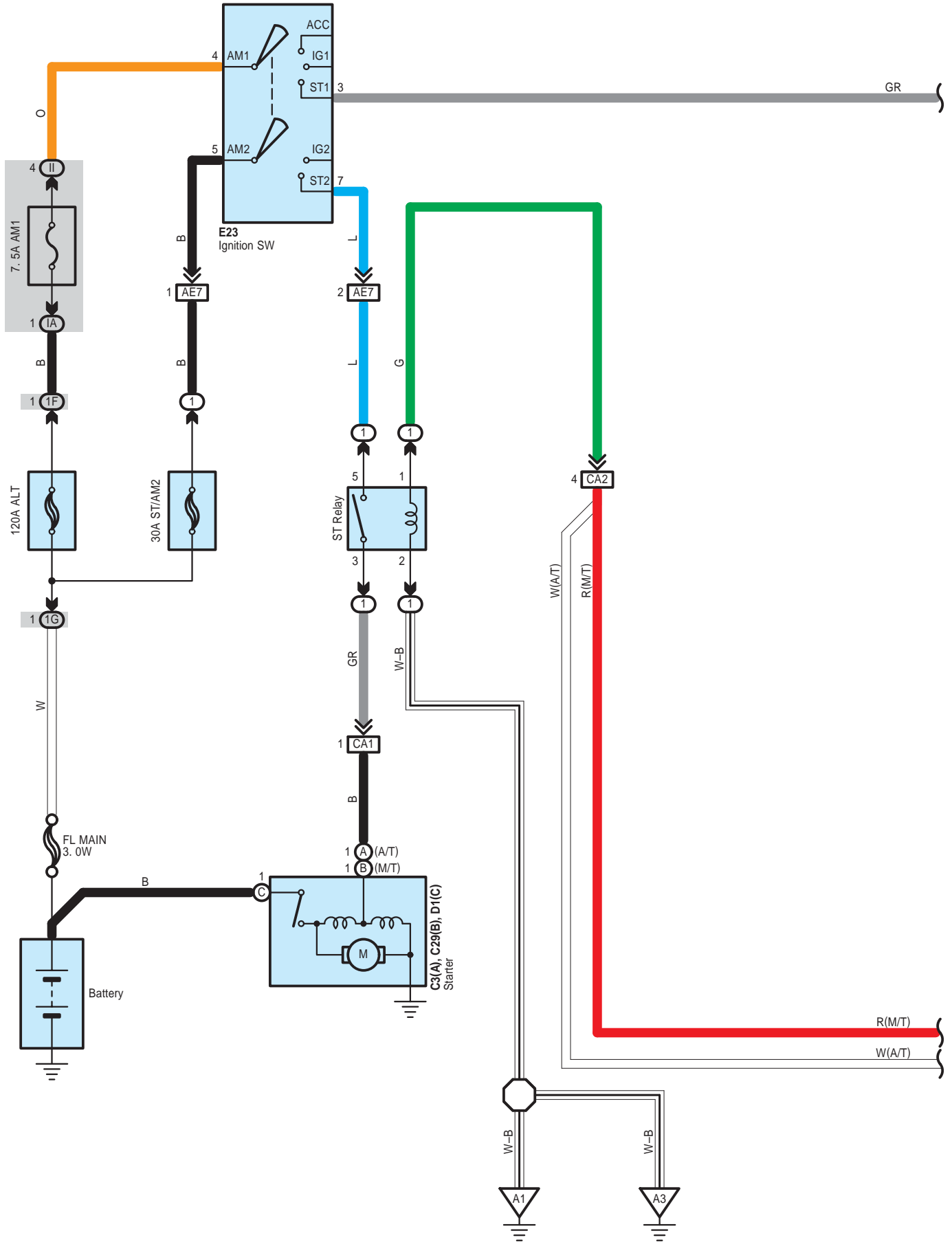

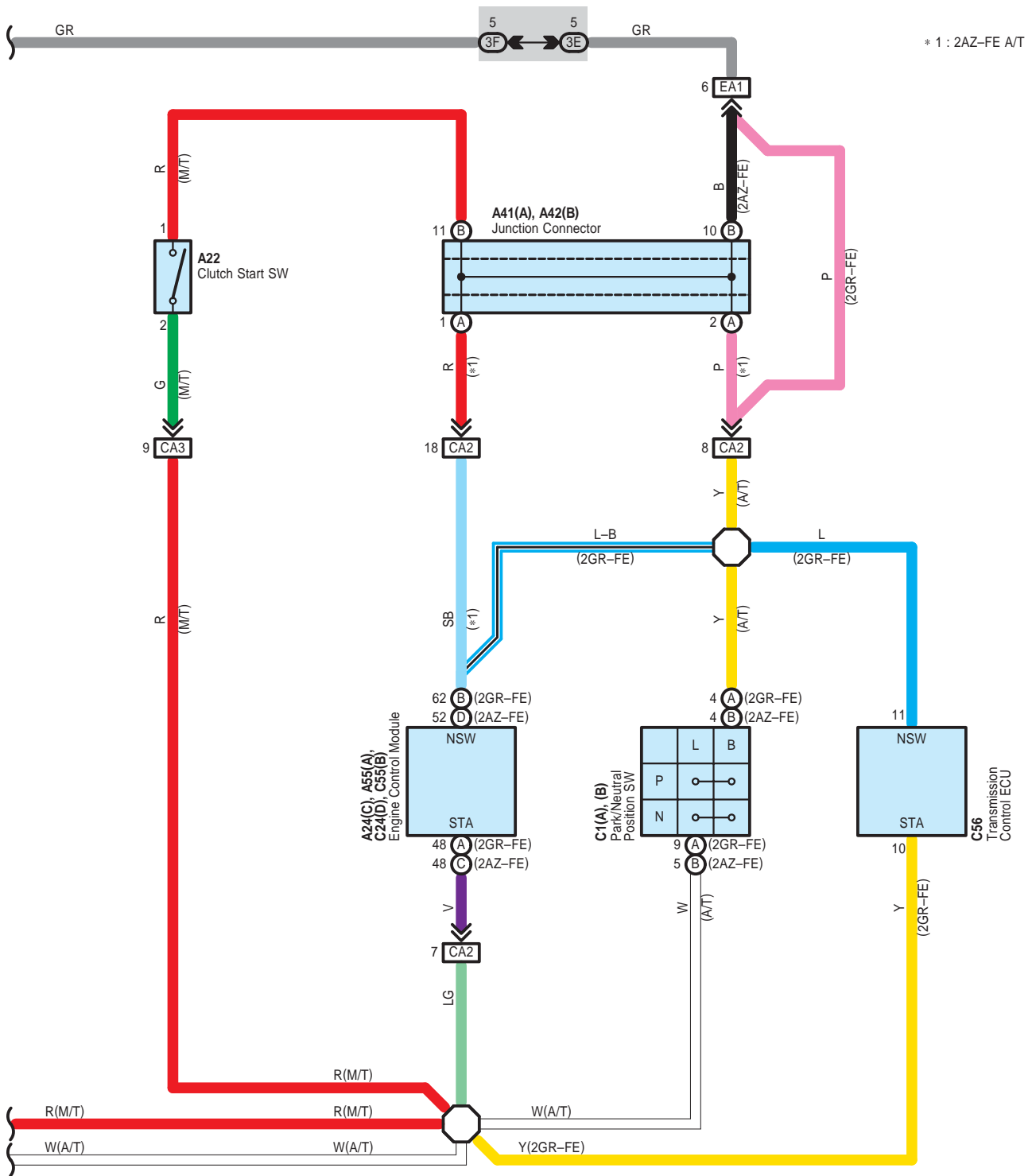

# Starting without Smart Key System

## : Parts Location

| Code |   | See Page    | Code |   | See Page    | Code |     | See Page    |             |
|------|---|-------------|------|---|-------------|------|-----|-------------|-------------|
| A22  |   | 59          | C1   | B | 54 (2AZ-FE) |      | C56 | 51 (2GR-FE) |             |
| A24  | C | 52 (2AZ-FE) | C3   | A | 50 (2GR-FE) |      | D1  | C           | 51 (2GR-FE) |
| A41  | A | 59          |      |   | 54 (2AZ-FE) |      |     |             | 55 (2AZ-FE) |
| A42  | B | 59          | C24  | D | 55 (2AZ-FE) |      | E23 | 56          |             |
| A55  | A | 49 (2GR-FE) | C29  | B | 55 (2AZ-FE) |      |     |             |             |
| C1   | A | 50 (2GR-FE) | C55  | B | 51 (2GR-FE) |      |     |             |             |

## : Relay Blocks

| Code | See Page | Relay Blocks (Relay Block Location)       |
|------|----------|---|
| 1    | 22       | Engine Room R/B (Engine Compartment Left) |

## : Junction Block and Wire Harness Connector

| Code | See Page | Junction Block and Wire Harness (Connector Location)                |
|------|----------|---|
| 1F   | 22       | Engine Room Main Wire and Engine Room J/B (Engine Compartment Left) |
| 1G   |          |   |
| 3E   | 36       | Instrument Panel Wire and J/B No.3 (Behind the Combination Meter)   |
| 3F   |          |   |
| IA   | 30       | Engine Room Main Wire and Instrument Panel J/B (Cowl Side Left)     |
| II   | 31       | Instrument Panel Wire and Instrument Panel J/B (Cowl Side Left)     |

## : Connector Joining Wire Harness and Wire Harness

| Code | See Page    | Joining Wire Harness and Wire Harness (Connector Location)                                |
|------|-------------|---|
| AE7  | 66          | Engine Room Main Wire and Instrument Panel Wire (Right Side of the Instrument Panel J/B)  |
| CA1  | 64 (2GR-FE) | Engine Wire and Engine Room Main Wire (Inside of the Engine Room R/B and Engine Room J/B) |
|      | 65 (2AZ-FE) |   |
| CA2  | 64 (2GR-FE) |   |
|      | 65 (2AZ-FE) |   |
| CA3  | 65 (2AZ-FE) |   |
| EA1  | 66          | Instrument Panel Wire and Engine Room Main Wire (Left Kick Panel)                         |

## : Ground Points

| Code | See Page    | Ground Points Location |
|------|-------------|------------------------|
| A1   | 64 (2GR-FE) | Front Left Fender      |
|      | 65 (2AZ-FE) |                        |
| A3   | 66          | Left Cowl Side Panel   |



# Charging

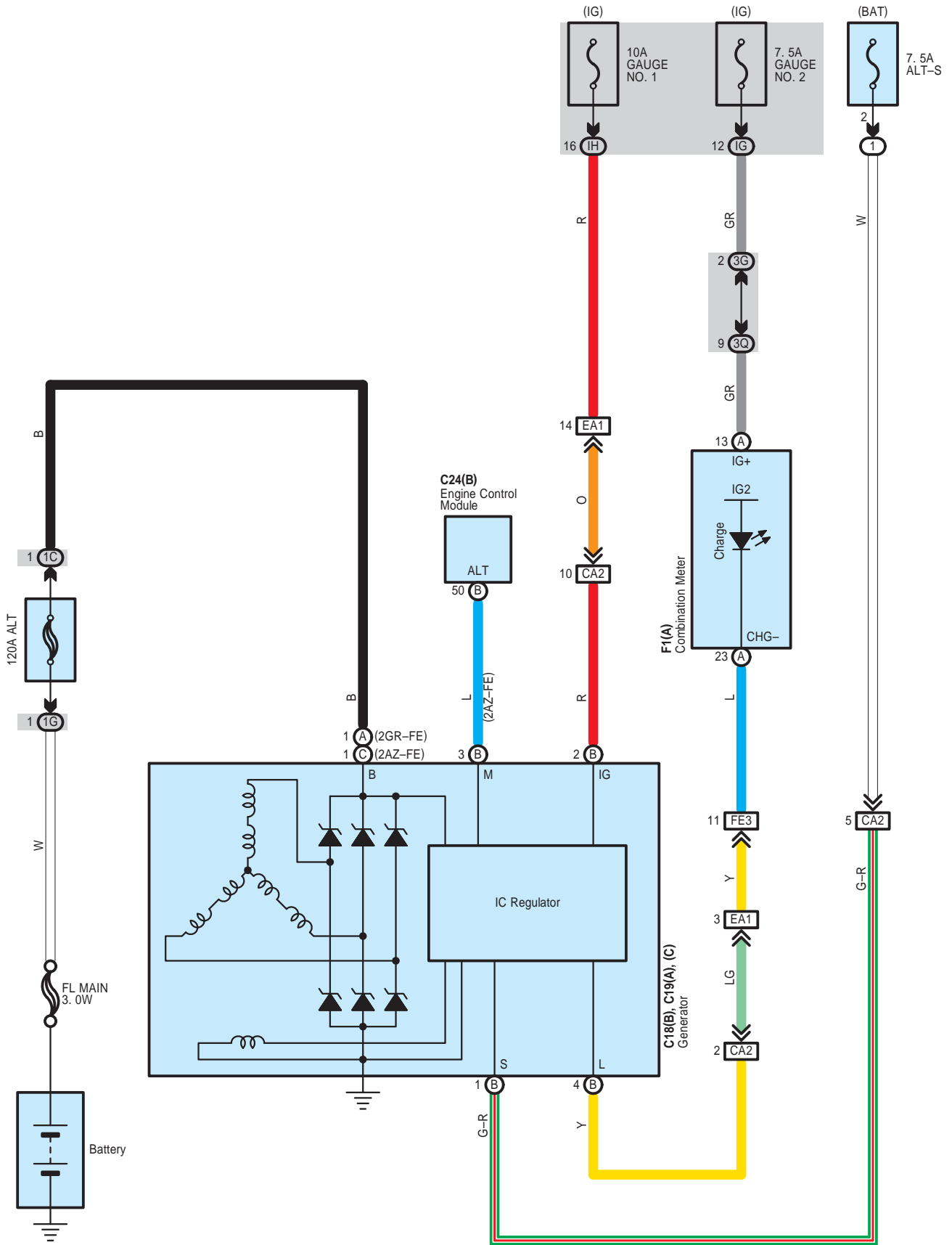

: **Parts Location**

| Code |   | See Page    | Code |   | See Page    | Code |   | See Page    |
|------|---|-------------|------|---|-------------|------|---|-------------|
| C18  | B | 50 (2GR-FE) | C19  | A | 50 (2GR-FE) | C24  | B | 55 (2AZ-FE) |
|      |   | 54 (2AZ-FE) |      | C | 54 (2AZ-FE) |      |   | F1          |

: **Relay Blocks**

| Code | See Page | Relay Blocks (Relay Block Location)       |
|------|----------|---|
| 1    | 22       | Engine Room R/B (Engine Compartment Left) |

: **Junction Block and Wire Harness Connector**

| Code | See Page | Junction Block and Wire Harness (Connector Location)                   |
|------|----------|--|
| 1C   | 22       | Engine Wire and Engine Room J/B (Engine Compartment Left)              |
| 1G   | 22       | Engine Room Main Wire and Engine Room J/B (Engine Compartment Left)    |
| 3G   | 36       | Instrument Panel Wire and J/B No.3 (Behind the Combination Meter)      |
| 3Q   | 36       | Instrument Panel No.2 Wire and J/B No.3 (Behind the Combination Meter) |
| IG   | 31       | Instrument Panel Wire and Instrument Panel J/B (Cowl Side Left)        |
| IH   |          |  |

: **Connector Joining Wire Harness and Wire Harness**

| Code | See Page    | Joining Wire Harness and Wire Harness (Connector Location)                                |
|------|-------------|---|
| CA2  | 64 (2GR-FE) | Engine Wire and Engine Room Main Wire (Inside of the Engine Room R/B and Engine Room J/B) |
|      | 65 (2AZ-FE) |   |
| EA1  | 66          | Instrument Panel Wire and Engine Room Main Wire (Left Kick Panel)                         |
| FE3  | 66          | Instrument Panel No.2 Wire and Instrument Panel Wire (Instrument Panel Center)            |

# Ignition for 2GR-FE

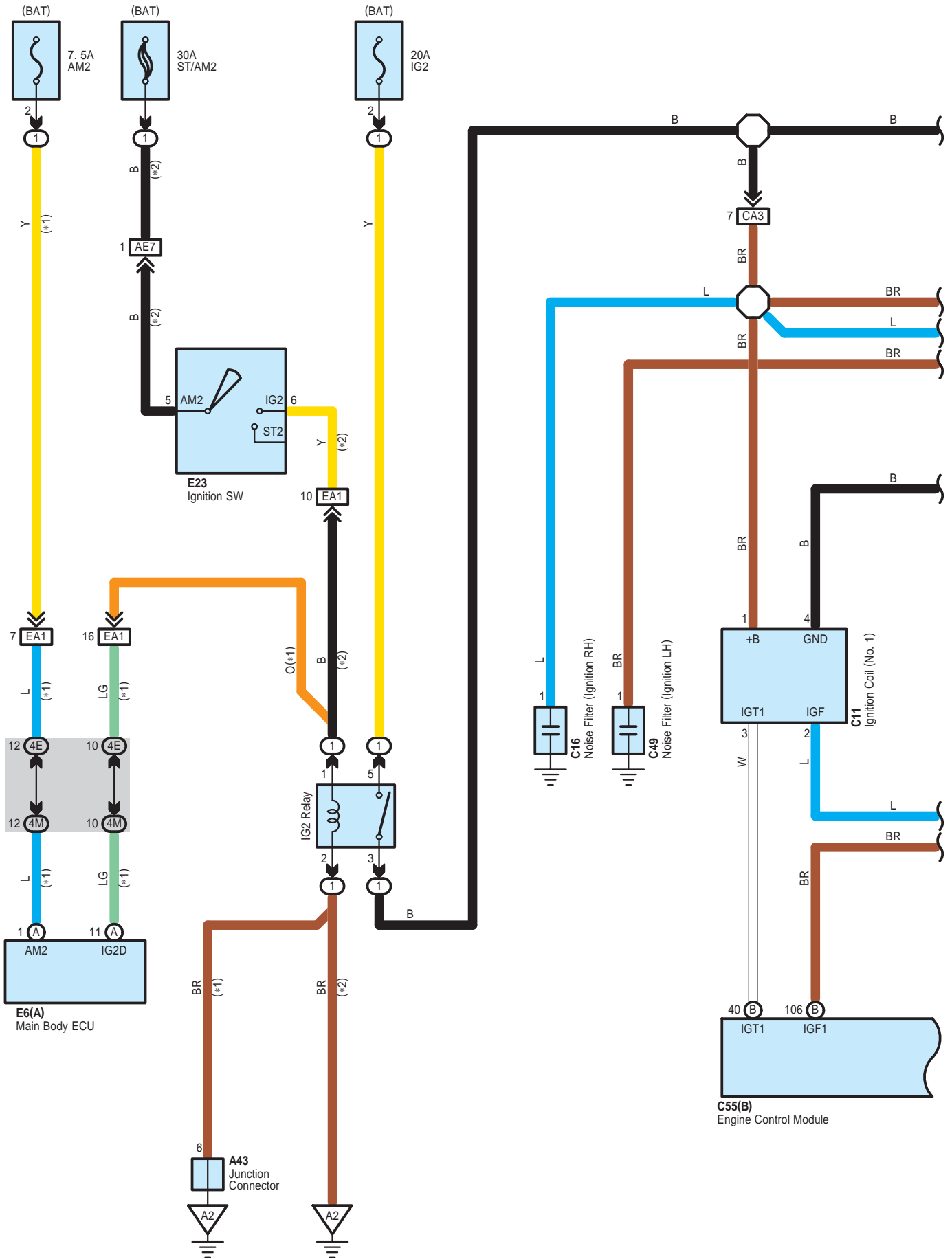

\* 1 : w/ Smart Key System  
 \* 2 : w/o Smart Key System

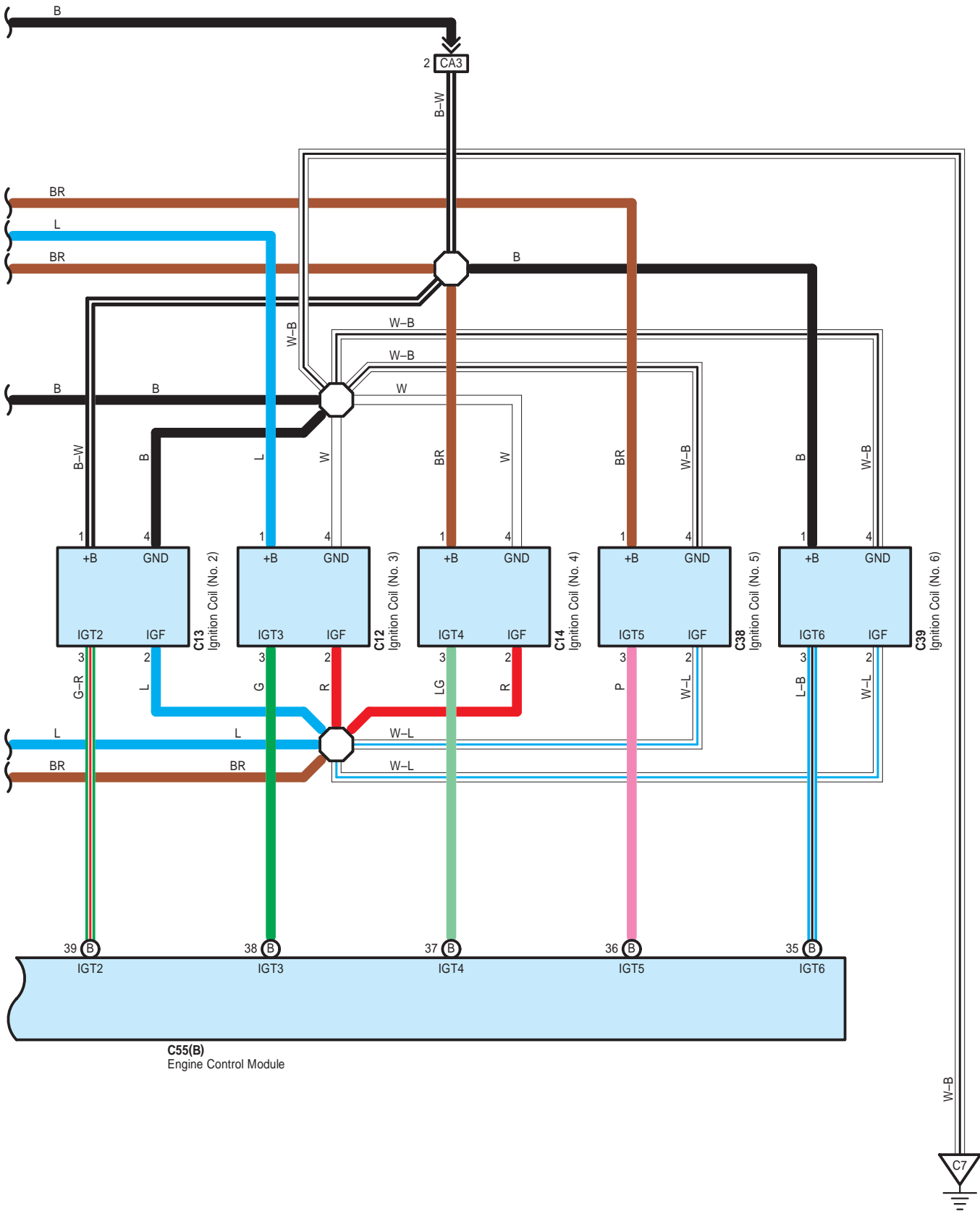



# Ignition for 2GR-FE

## ○ : Parts Location

| Code | See Page    | Code | See Page    | Code | See Page      |
|------|-------------|------|-------------|------|---------------|
| A43  | 49 (2GR-FE) | C14  | 50 (2GR-FE) | C49  | 51 (2GR-FE)   |
| C11  | 50 (2GR-FE) | C16  | 50 (2GR-FE) | C55  | B 51 (2GR-FE) |
| C12  | 50 (2GR-FE) | C38  | 51 (2GR-FE) | E6   | A 56          |
| C13  | 50 (2GR-FE) | C39  | 51 (2GR-FE) | E23  | 56            |

## ○ : Relay Blocks

| Code | See Page | Relay Blocks (Relay Block Location)       |
|------|----------|---|
| 1    | 22       | Engine Room R/B (Engine Compartment Left) |

## ○ : Junction Block and Wire Harness Connector

| Code | See Page | Junction Block and Wire Harness (Connector Location)               |
|------|----------|--|
| 4E   | 42       | Instrument Panel Wire and J/B No.4 (Instrument Panel Brace Center) |
| 4M   |          |  |

## □ : Connector Joining Wire Harness and Wire Harness

| Code | See Page    | Joining Wire Harness and Wire Harness (Connector Location)                                |
|------|-------------|---|
| AE7  | 66          | Engine Room Main Wire and Instrument Panel Wire (Right Side of the Instrument Panel J/B)  |
| CA3  | 64 (2GR-FE) | Engine Wire and Engine Room Main Wire (Inside of the Engine Room R/B and Engine Room J/B) |
| EA1  | 66          | Instrument Panel Wire and Engine Room Main Wire (Left Kick Panel)                         |

## ▽ : Ground Points

| Code | See Page    | Ground Points Location          |
|------|-------------|---------------------------------|
| A2   | 64 (2GR-FE) | Front Left Fender               |
| C7   | 64 (2GR-FE) | Left Side of the Cylinder Block |



# Ignition for 2AZ-FE

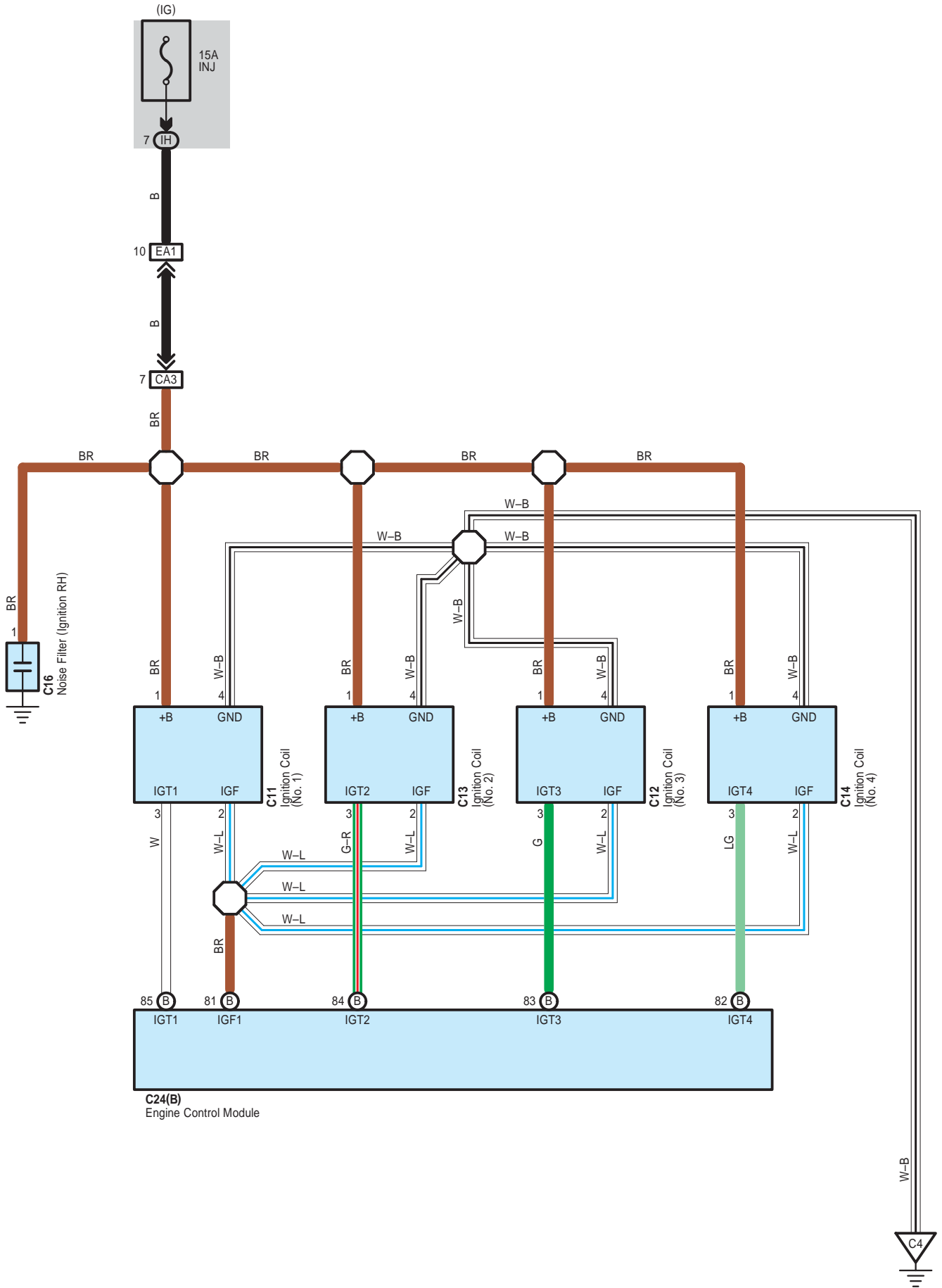

 : **Parts Location**

| Code | See Page    | Code | See Page    | Code | See Page      |
|------|-------------|------|-------------|------|---------------|
| C11  | 54 (2AZ-FE) | C13  | 54 (2AZ-FE) | C16  | 54 (2AZ-FE)   |
| C12  | 54 (2AZ-FE) | C14  | 54 (2AZ-FE) | C24  | B 55 (2AZ-FE) |

 : **Junction Block and Wire Harness Connector**

| Code | See Page | Junction Block and Wire Harness (Connector Location)            |
|------|----------|---|
| IH   | 31       | Instrument Panel Wire and Instrument Panel J/B (Cowl Side Left) |

 : **Connector Joining Wire Harness and Wire Harness**

| Code | See Page    | Joining Wire Harness and Wire Harness (Connector Location)                                |
|------|-------------|---|
| CA3  | 65 (2AZ-FE) | Engine Wire and Engine Room Main Wire (Inside of the Engine Room R/B and Engine Room J/B) |
| EA1  | 66          | Instrument Panel Wire and Engine Room Main Wire (Left Kick Panel)                         |

 : **Ground Points**

| Code | See Page    | Ground Points Location |
|------|-------------|------------------------|
| C4   | 65 (2AZ-FE) | Cylinder Block         |

# Engine Control for 2GR-FE

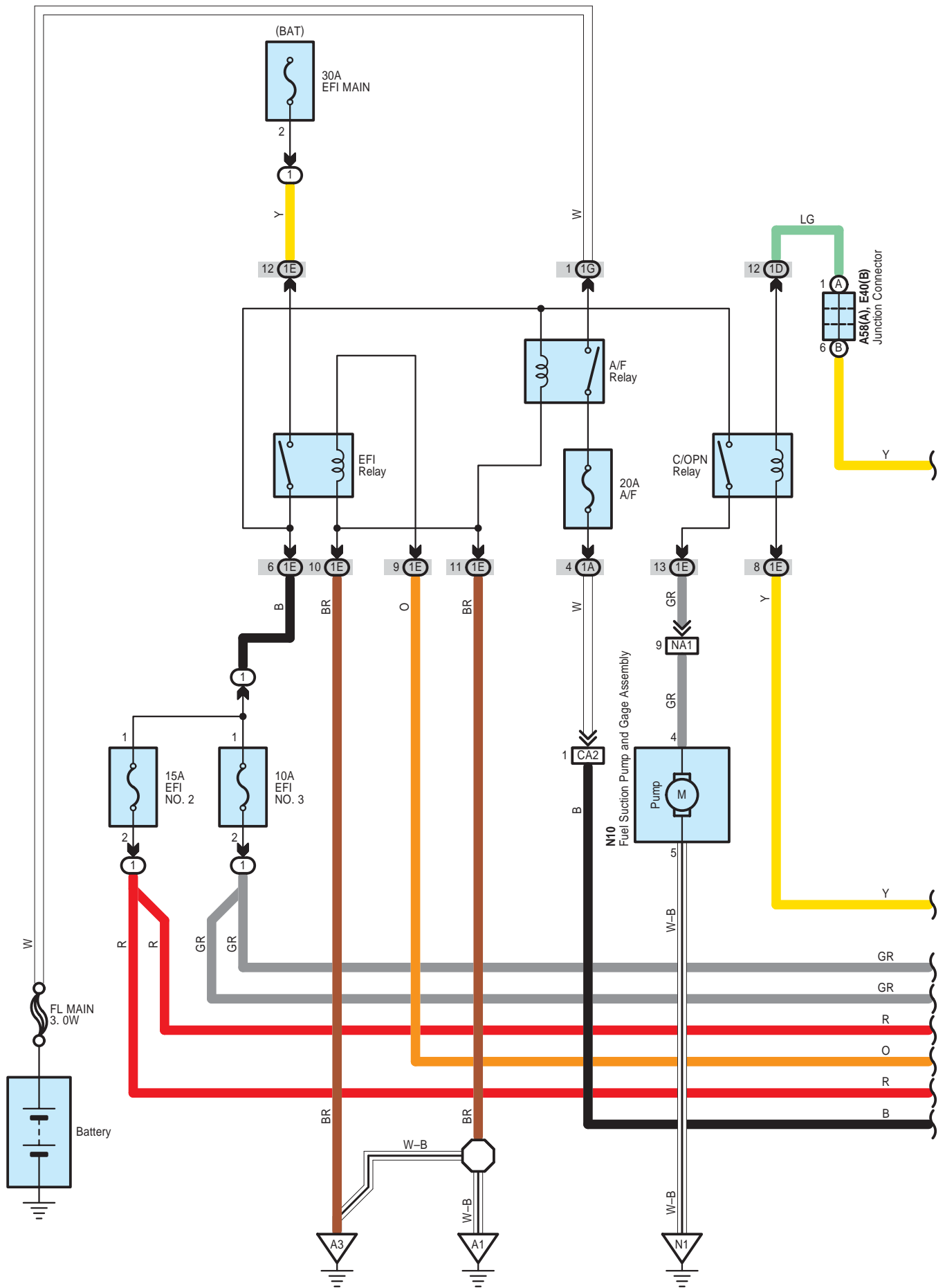

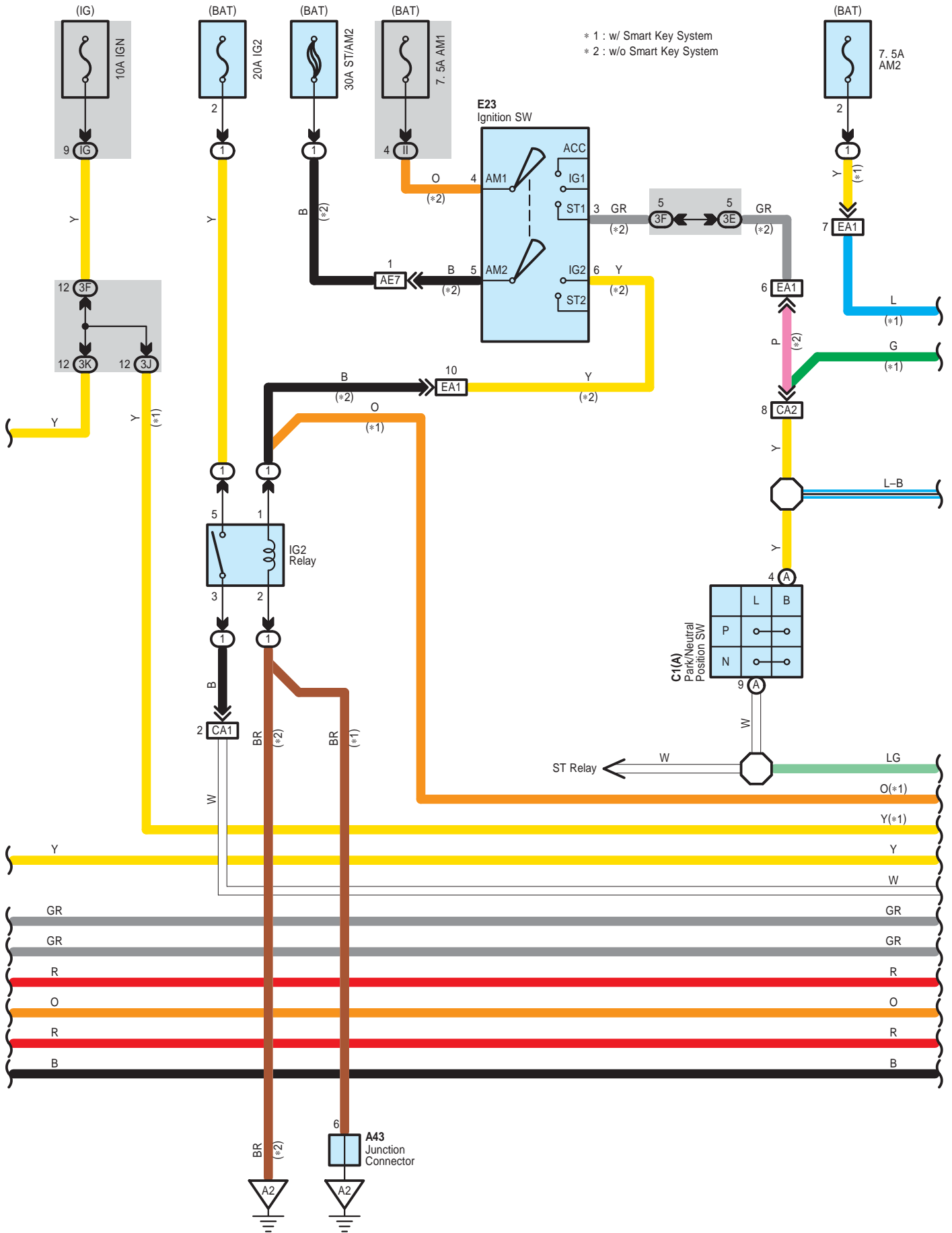

# Engine Control for 2GR-FE

E6(A), E7(B), E8(C), E9(D)  
Main Body ECU

\* 1 : w/ Smart Key System

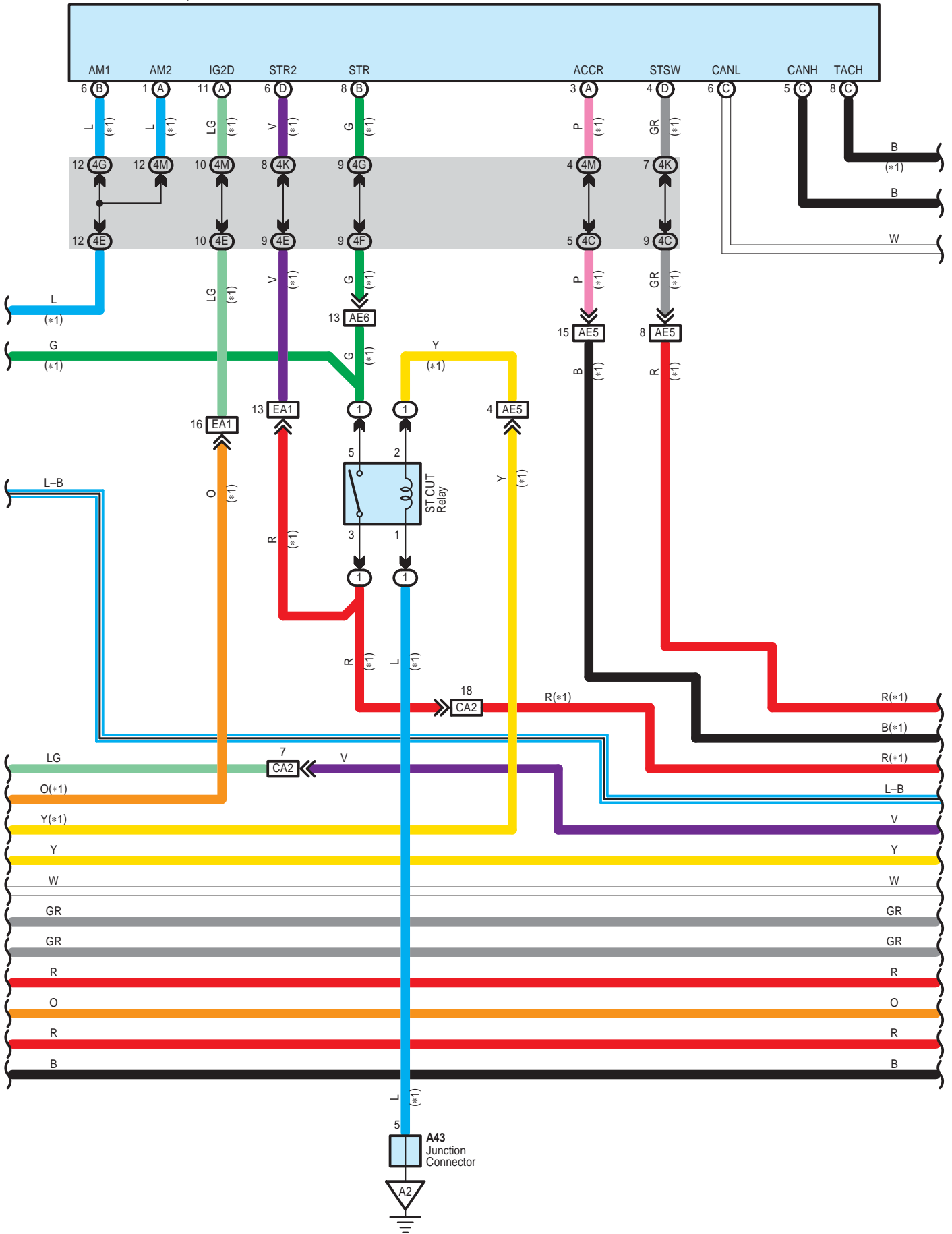

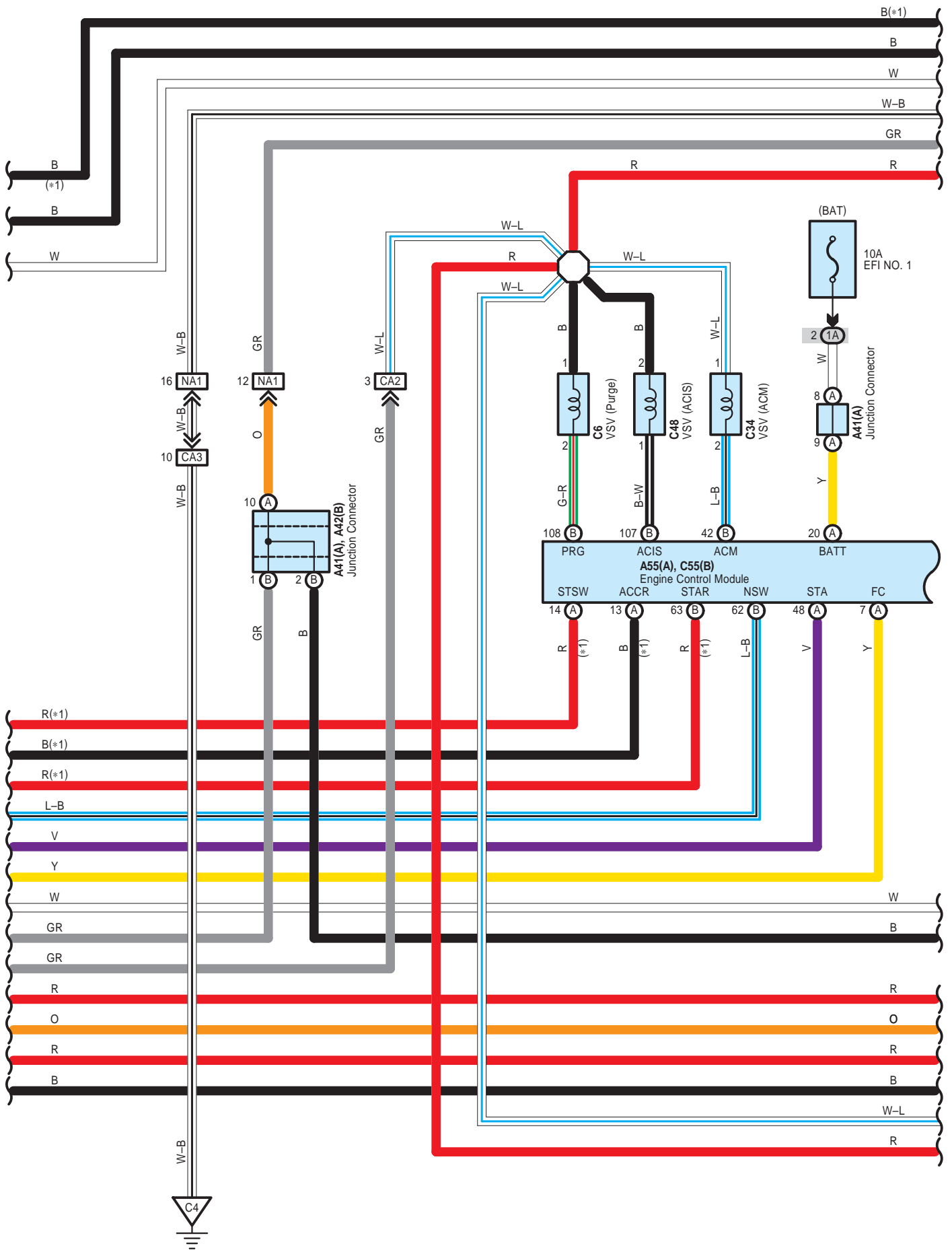



# Engine Control for 2GR-FE

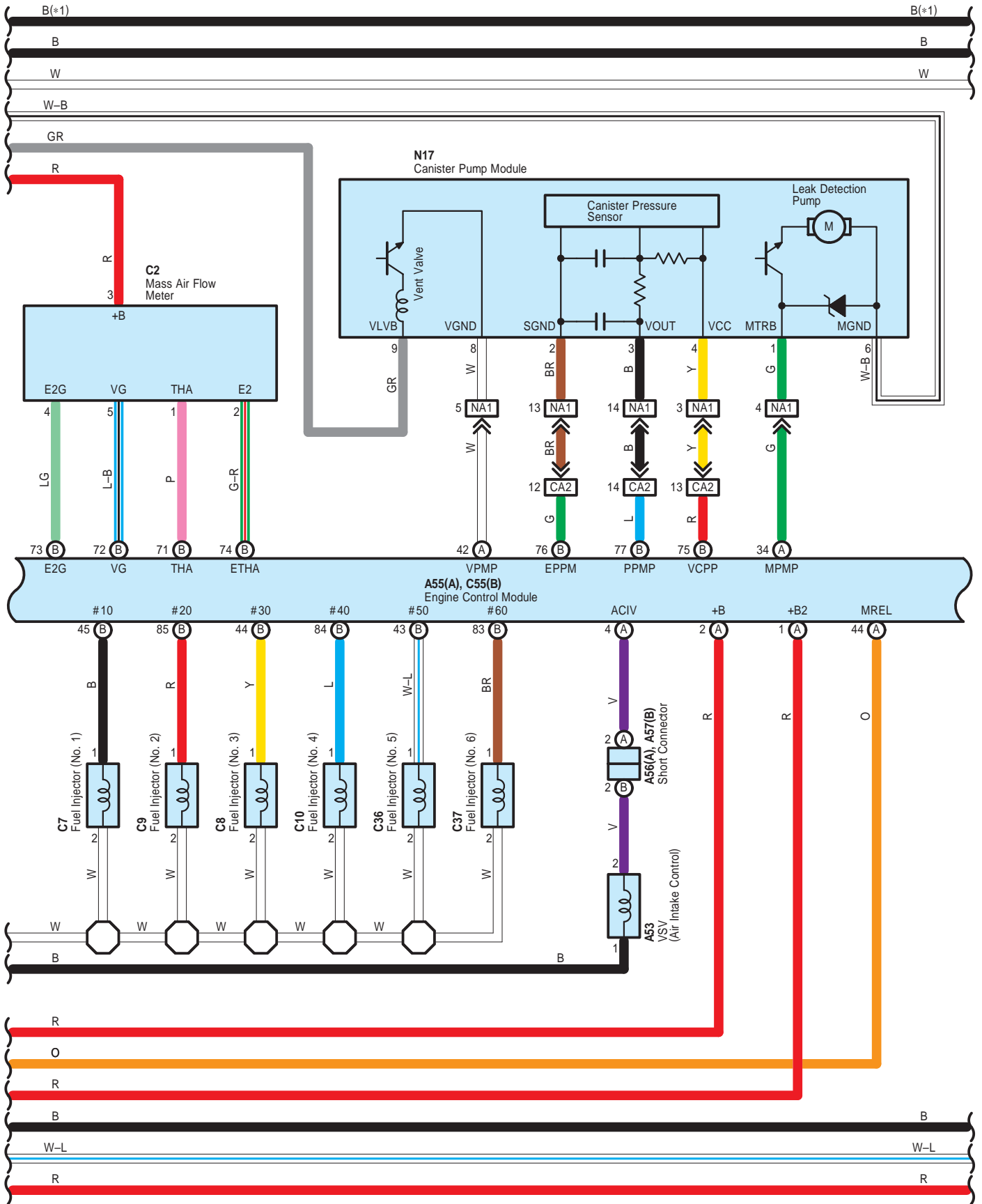

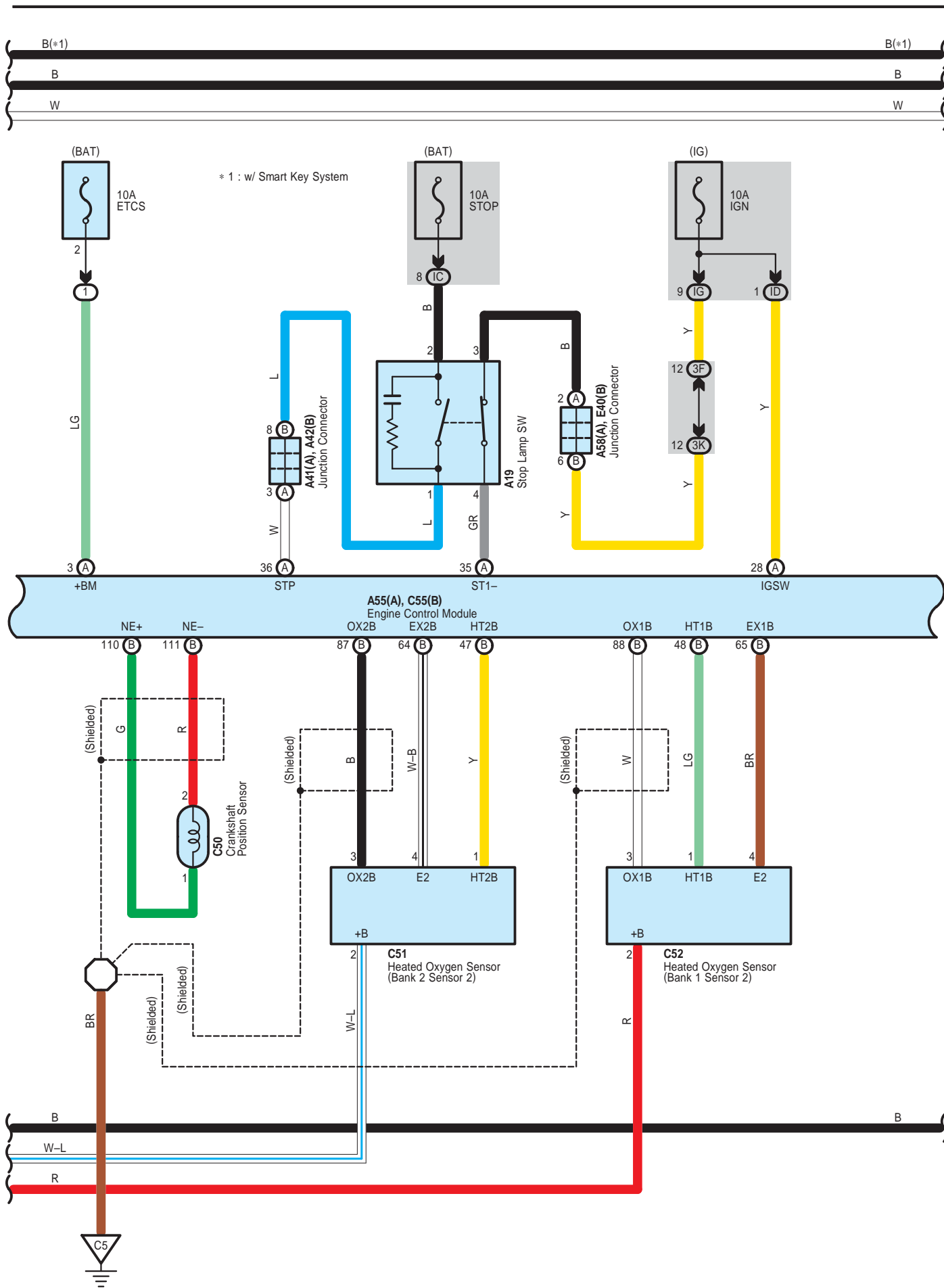

# Engine Control for 2GR-FE

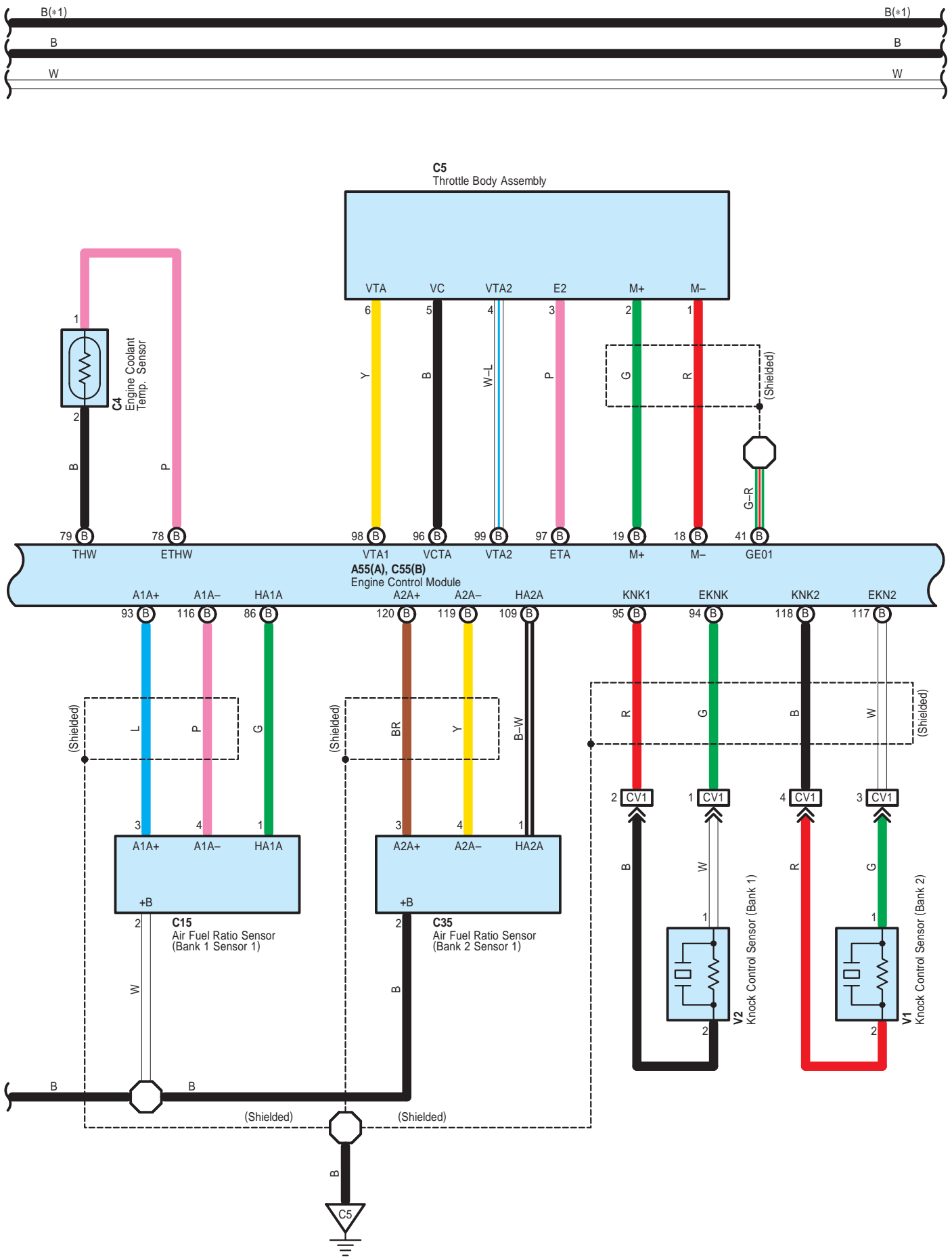

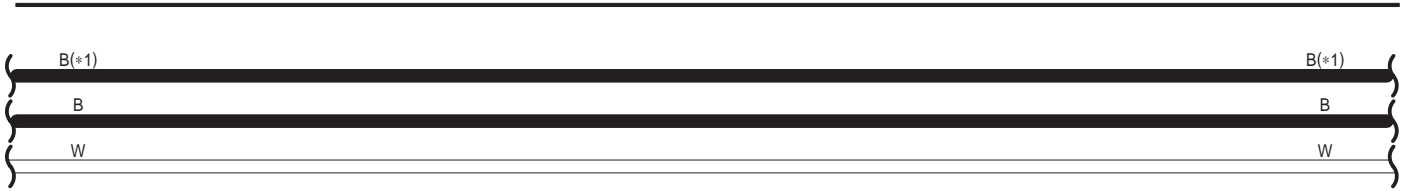

\* 1 : w/ Smart Key System

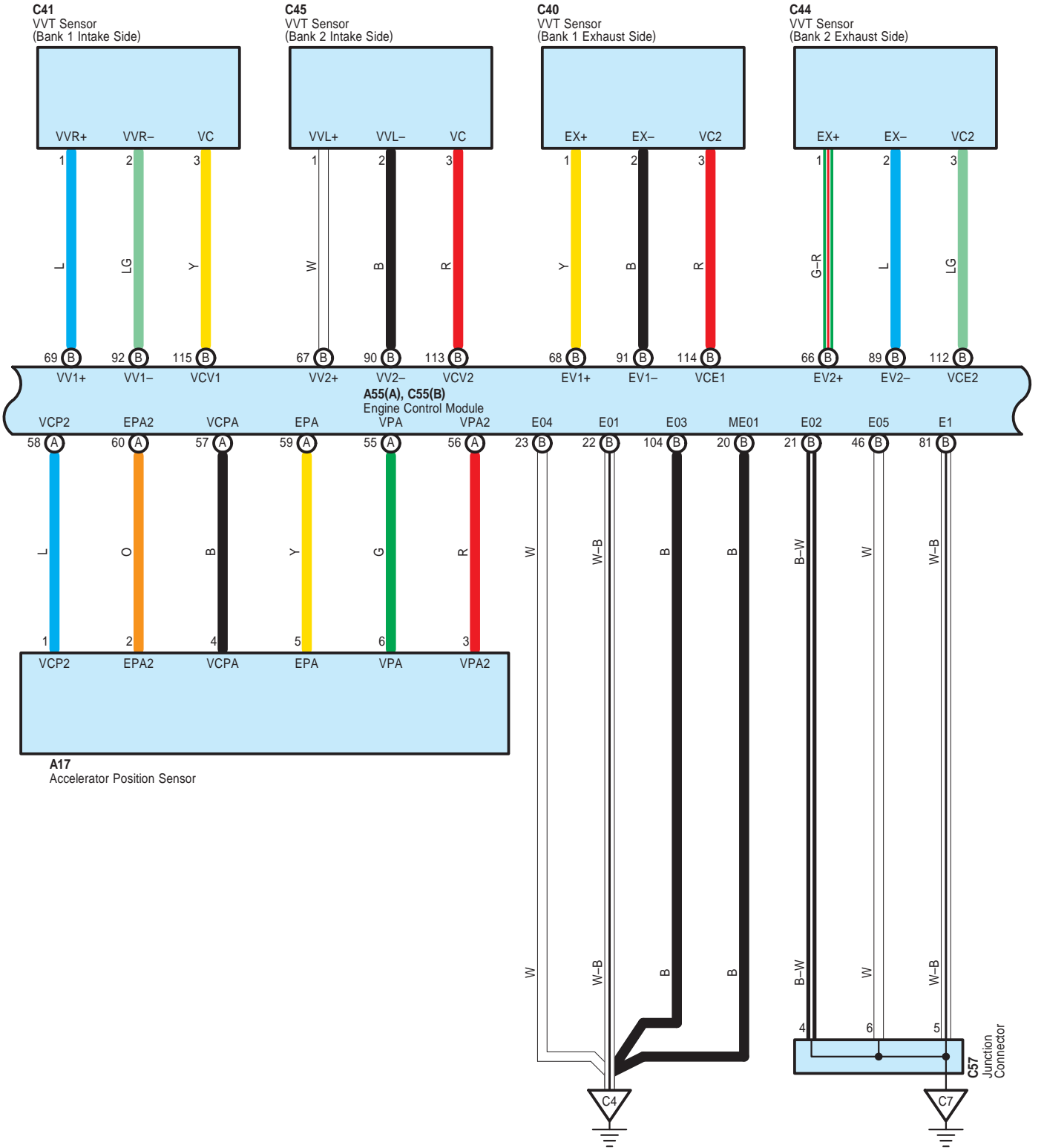

# Engine Control for 2GR-FE

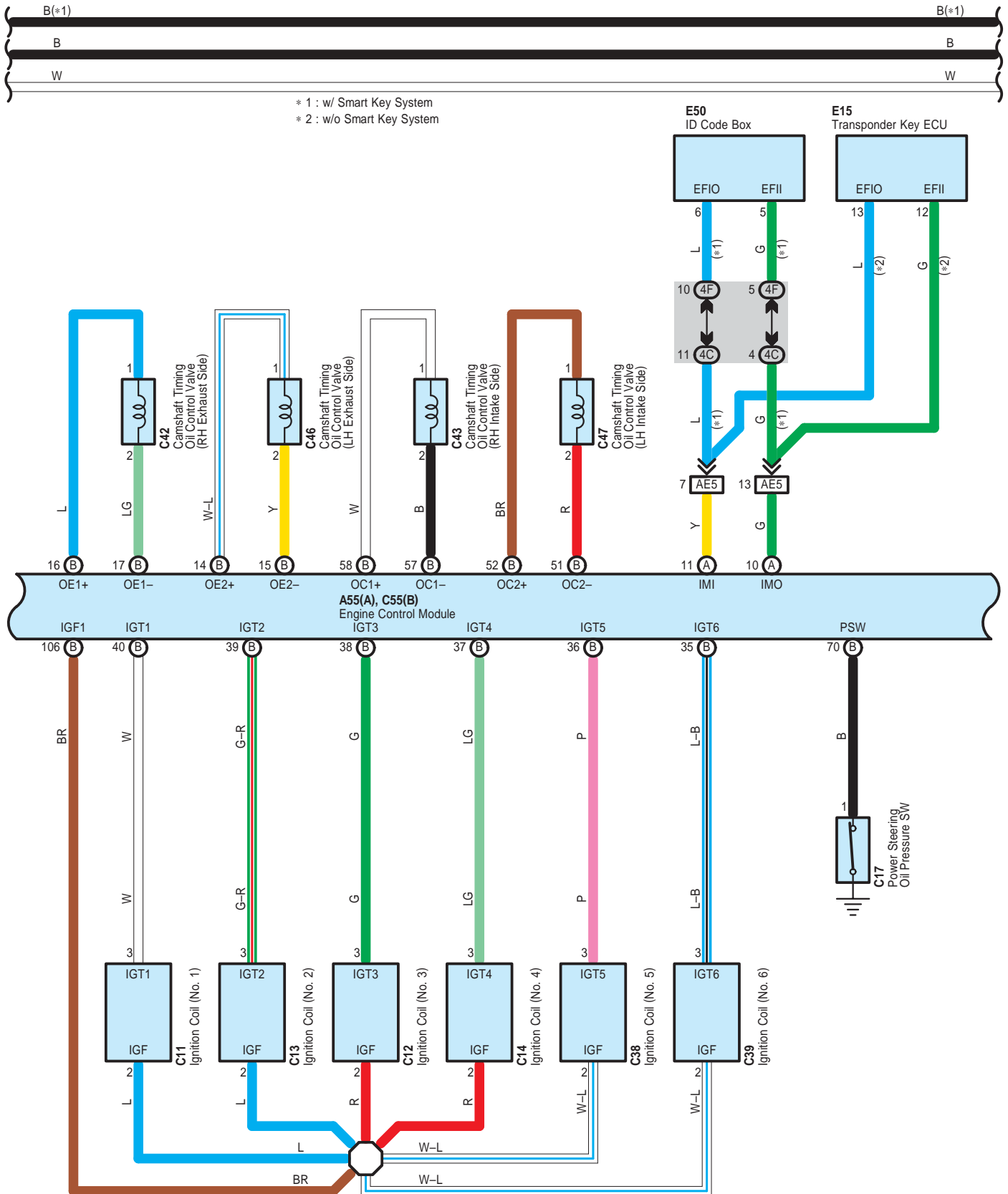

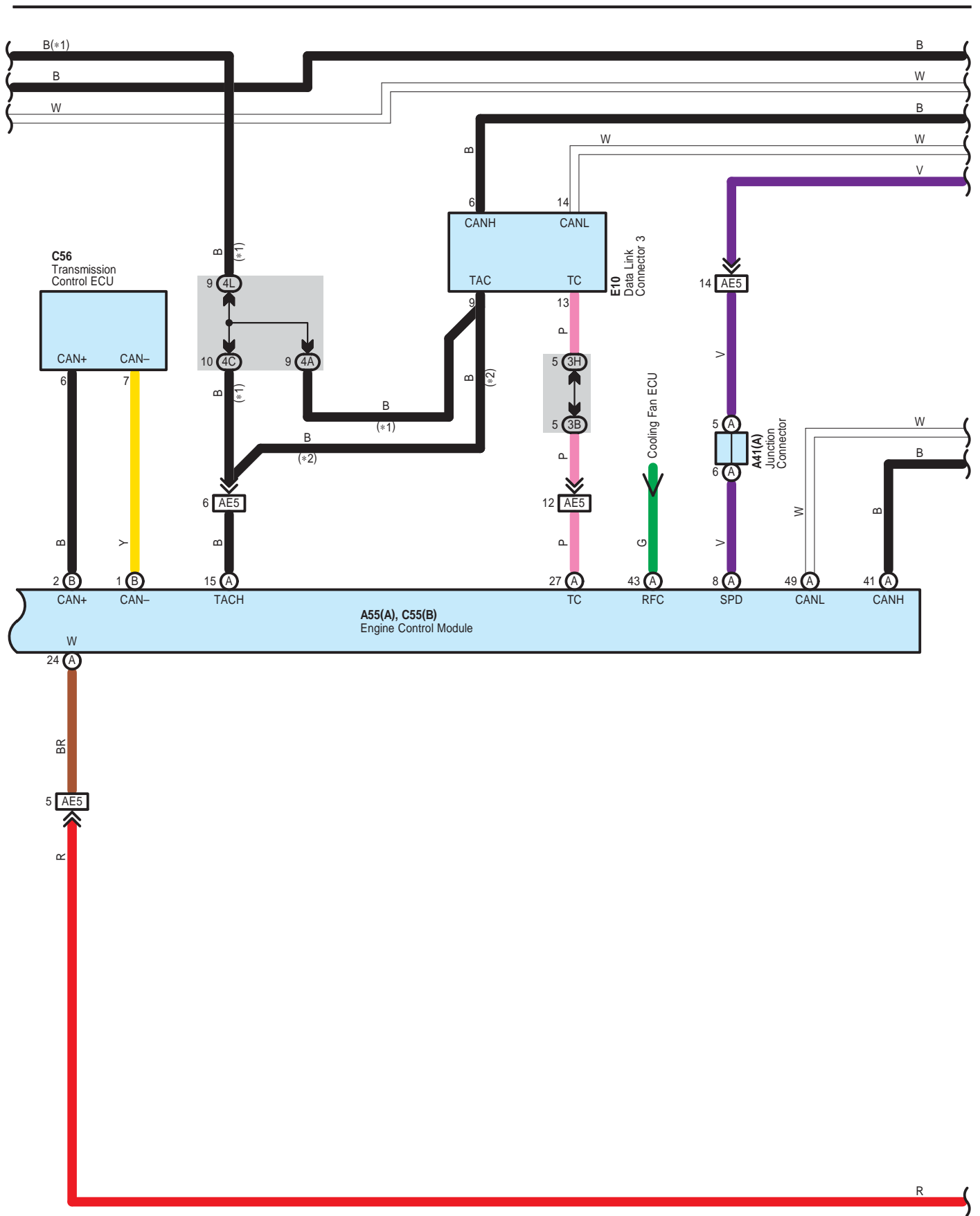

# Engine Control for 2GR-FE

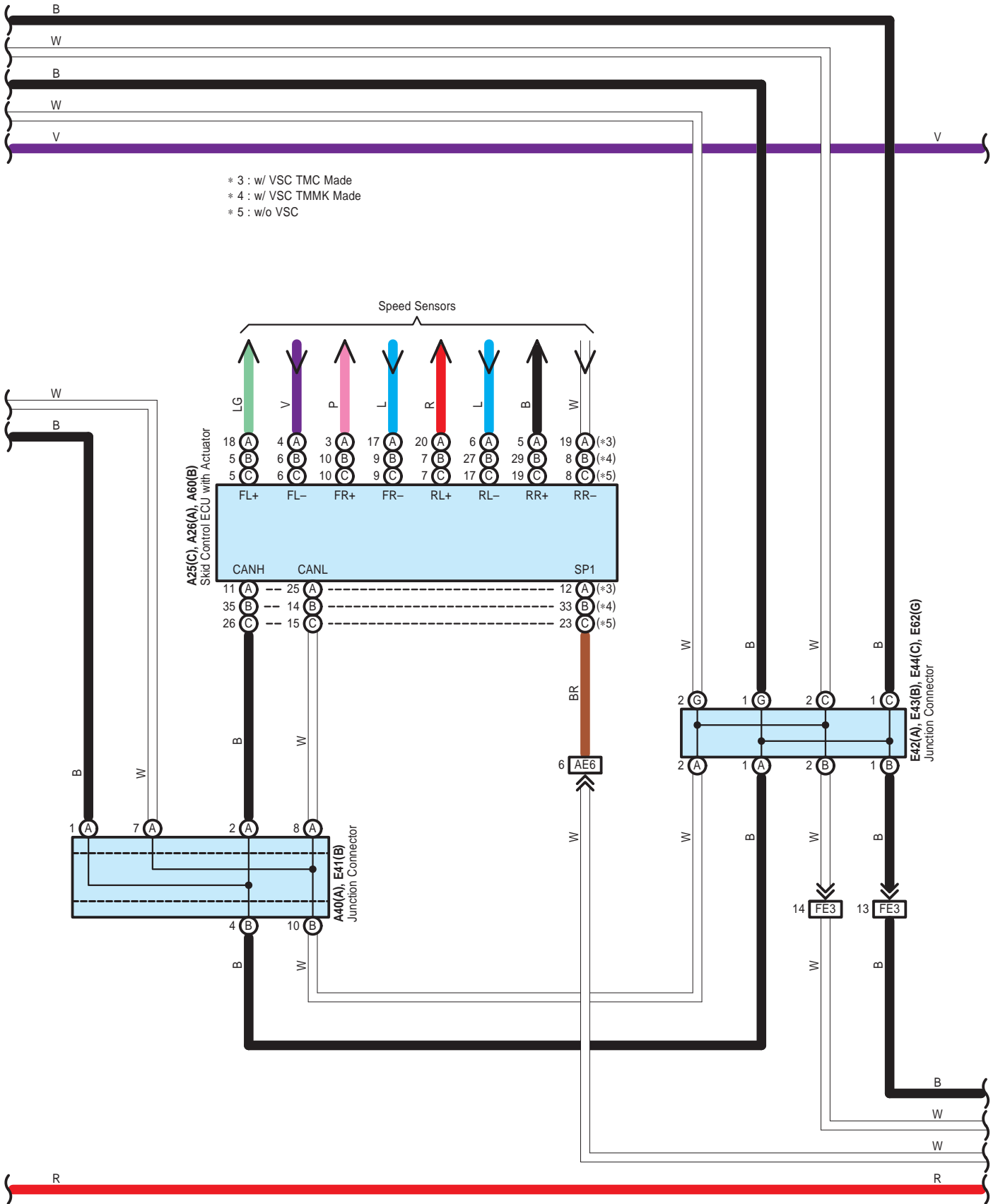

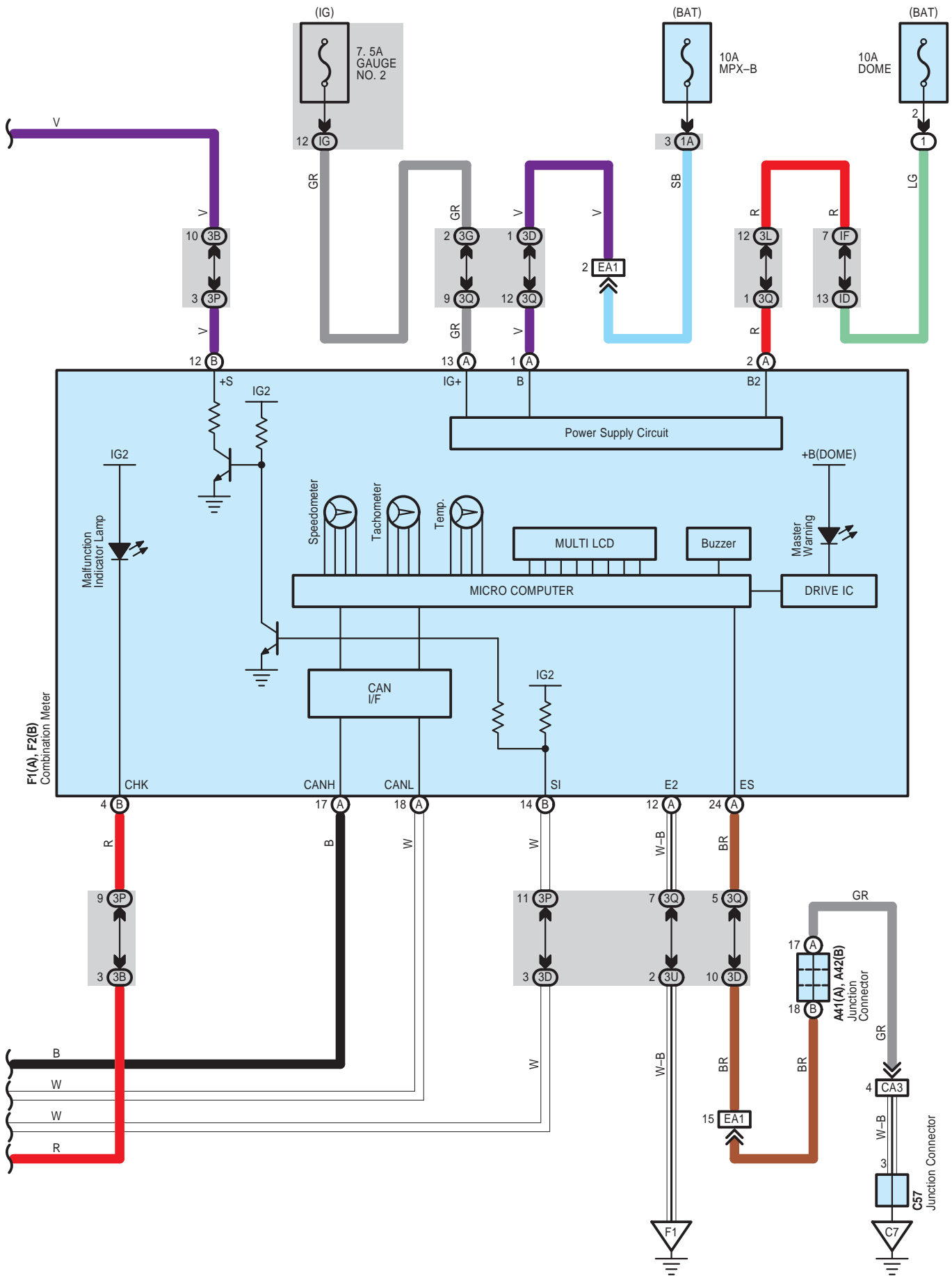

CAMRY (EM0250U)



## System Outline

The engine control system utilizes a microcomputer and maintains overall control of the engine, transaxle etc. An outline of the engine control is given here.

### 1. Input Signals

#### (1) Engine coolant temp. signal circuit

The engine coolant temp. sensor detects the engine coolant temp. and has a built-in thermistor with a resistance which varies according to the engine coolant temp. The engine coolant temp. is input into TERMINAL THW of the engine control module as a control signal.

#### (2) Intake air temp. signal circuit

The intake air temp. sensor is installed in the mass air flow meter and detects the intake air temp., which is input as a control signal to TERMINAL THA of the engine control module.

#### (3) Oxygen sensor signal circuit

The oxygen density in the exhaust emission is detected and is input as a control signal from the heated oxygen sensors to TERMINALS OX1B and OX2B of the engine control module.

#### (4) RPM signal circuit

Camshaft position is detected by the VVT sensor (Bank 1 exhaust side, bank 1 intake side, bank 2 exhaust side and bank 2 intake side), and their signals are input to TERMINALS EV1+, EV2+, VV1+ and VV2+ of the engine control module as control signals. Also, the engine RPM is detected by the crankshaft position sensor installed in the cylinder block and the signal is input into TERMINAL NE+ of the engine control module as a control signal.

#### (5) Throttle position sensor signal circuit

The throttle position sensor detects the throttle valve opening angle as a control signal, which is input into TERMINALS VTA1 and VTA2 of the engine control module.

#### (6) Vehicle speed circuit

The vehicle speed sensor detects the vehicle speed, and the signal is input into TERMINAL SPD of the engine control module via the combination meter, from TERMINAL SP1 of the skid control ECU with actuator.

#### (7) Battery signal circuit

Voltage is constantly applied to TERMINAL BATT of the engine control module. When the power SW is pushed on (Power SW type), or when the ignition SW is turned on (Ignition SW type), the voltage for engine control module start-up power supply is applied to TERMINAL +B and +B2 of engine control module via EFI relay.

#### (8) Intake air volume signal circuit

The intake air volume is detected by the mass air flow meter, and is input as a control signal to TERMINAL VG of the engine control module.

#### (9) Stop lamp SW signal circuit

The stop lamp SW is used to detect whether the vehicle is braking or not, and the signal is input into TERMINAL STP of the engine control module as a control signal.

#### (10) Starter signal circuit

To confirm whether the engine is cranking, the voltage applied to the starter motor when the engine is cranking is detected, and is input into TERMINAL STA of the engine control module as a control signal.

#### (11) Engine knock signal circuit

Engine knocking is detected by the knock control sensors, and is input into TERMINALS KNK1 and KNK2 of the engine control module as a control signal.

#### (12) Air fuel ratio signal circuit

The air fuel ratio is detected and input as a control signal into TERMINALS A1A+, A2A+ of the engine control module.

## 2. Control System

### \* SFI system

The SFI system monitors the engine condition through the signals input from each sensors to the engine control module. The control signal is sent to the engine control module TERMINALS #10, #20, #30, #40, #50 and #60 to operate the injector (Fuel injection). The SFI system controls the fuel injection by the engine control module in response to the driving conditions.

### \* ESA system

The ESA system monitors the engine condition through the signals input from each sensors to the engine control module. The best ignition timing is decided according to this data and the data memorized in the engine control module. The control signal is output to TERMINALS IGT1, IGT2, IGT3, IGT4, IGT5 and IGT6, and these signals control the igniter to provide the best ignition timing.

### \* Heated oxygen sensor heater control system

The heated oxygen sensor heater control system turns the heater on when the intake air volume is low (Temp. of exhaust emission is low), and warms up the heated oxygen sensors to improve their detection performance. The engine control module evaluates the signals from each sensors, and outputs current to TERMINALS HT1B or HT2B to control the heater.

### \* Air fuel ratio sensor heater control system

The air fuel ratio sensor heater control system turns the heater on when the intake air volume is low (Temp. of exhaust emission is low), and warms up the air fuel ratio sensor to improve detection performance of the sensor.

The engine control module evaluates the signals from each sensor, current is output to TERMINALS HA1A and HA2A, controlling the heater.

### \* ACIS

The ACIS includes a valve in the bulkhead separating the surge tank into two parts. This valve is opened and closed in accordance with the driving conditions to control the intake manifold length in two stages, for increased engine output in all ranges from low to high speeds.

### \* ETCS-i

The ETCS-i controls the engine output at its optimal level in accordance with the opening of the accelerator pedal, under all driving conditions.

### \* Dual VVT-i

Dual VVT-i controls the intake and exhaust valve timing to the most appropriate levels in accordance with the engine conditions.

## 3. Diagnosis System

When there is a malfunction in the engine control module signal system, the malfunctioning system is recorded in the memory. The malfunctioning system can be found by reading the code displayed on the malfunction indicator lamp.

## 4. Fail-Safe System

When a malfunction has occurred in any system, there is a possibility of causing engine trouble due to continued control based on that system. In that case, the fail-safe system either controls the system using the data (Standard values) recorded in the engine control module memory, or else stops the engine.

# Engine Control for 2GR-FE

## ○ : Parts Location

| Code |   | See Page    | Code |   | See Page    | Code |   | See Page    |
|------|---|-------------|------|---|-------------|------|---|-------------|
| A17  |   | 59          | C12  |   | 50 (2GR-FE) | C56  |   | 51 (2GR-FE) |
| A19  |   | 59          | C13  |   | 50 (2GR-FE) | C57  |   | 51 (2GR-FE) |
| A25  | C | 48 (2GR-FE) | C14  |   | 50 (2GR-FE) | E6   | A | 56          |
| A26  | A | 48 (2GR-FE) | C15  |   | 50 (2GR-FE) | E7   | B | 56          |
| A40  | A | 59          | C17  |   | 50 (2GR-FE) | E8   | C | 56          |
| A41  | A | 59          | C34  |   | 51 (2GR-FE) | E9   | D | 56          |
| A42  | B | 59          | C35  |   | 51 (2GR-FE) | E10  |   | 56          |
| A43  |   | 49 (2GR-FE) | C36  |   | 51 (2GR-FE) | E15  |   | 56          |
| A53  |   | 49 (2GR-FE) | C37  |   | 51 (2GR-FE) | E23  |   | 56          |
| A55  | A | 49 (2GR-FE) | C38  |   | 51 (2GR-FE) | E40  | B | 57          |
| A56  | A | 59          | C39  |   | 51 (2GR-FE) | E41  | B | 57          |
| A57  | B | 59          | C40  |   | 51 (2GR-FE) | E42  | A | 57          |
| A58  | A | 59          | C41  |   | 51 (2GR-FE) | E43  | B | 57          |
| A60  | B | 49 (2GR-FE) | C42  |   | 51 (2GR-FE) | E44  | C | 57          |
| C1   | A | 50 (2GR-FE) | C43  |   | 51 (2GR-FE) | E50  |   | 57          |
| C2   |   | 50 (2GR-FE) | C44  |   | 51 (2GR-FE) | E62  | G | 57          |
| C4   |   | 50 (2GR-FE) | C45  |   | 51 (2GR-FE) | F1   | A | 58          |
| C5   |   | 50 (2GR-FE) | C46  |   | 51 (2GR-FE) | F2   | B | 58          |
| C6   |   | 50 (2GR-FE) | C47  |   | 51 (2GR-FE) | N10  |   | 60          |
| C7   |   | 50 (2GR-FE) | C48  |   | 51 (2GR-FE) | N17  |   | 60          |
| C8   |   | 50 (2GR-FE) | C50  |   | 51 (2GR-FE) | V1   |   | 51 (2GR-FE) |
| C9   |   | 50 (2GR-FE) | C51  |   | 51 (2GR-FE) | V2   |   | 51 (2GR-FE) |
| C10  |   | 50 (2GR-FE) | C52  |   | 51 (2GR-FE) |      |   |             |
| C11  |   | 50 (2GR-FE) | C55  | B | 51 (2GR-FE) |      |   |             |

## ○ : Relay Blocks

| Code | See Page | Relay Blocks (Relay Block Location)       |
|------|----------|---|
| 1    | 22       | Engine Room R/B (Engine Compartment Left) |

 : Junction Block and Wire Harness Connector

| Code | See Page | Junction Block and Wire Harness (Connector Location)                   |
|------|----------|--|
| 1A   | 25       | Engine Room Main Wire and Engine Room J/B (Engine Compartment Left)    |
| 1D   |          |  |
| 1E   |          |  |
| 1G   | 22       |  |
| 3B   | 36       | Instrument Panel Wire and J/B No.3 (Behind the Combination Meter)      |
| 3D   |          |  |
| 3E   |          |  |
| 3F   |          |  |
| 3G   |          |  |
| 3H   |          |  |
| 3J   |          |  |
| 3K   |          |  |
| 3L   |          |  |
| 3P   | 36       | Instrument Panel No.2 Wire and J/B No.3 (Behind the Combination Meter) |
| 3Q   |          |  |
| 3U   |          |  |
| 4A   | 42       | Instrument Panel Wire and J/B No.4 (Instrument Panel Brace Center)     |
| 4C   |          |  |
| 4E   |          |  |
| 4F   |          |  |
| 4G   |          |  |
| 4K   |          |  |
| 4L   |          |  |
| 4M   |          |  |
| IC   | 30       | Engine Room Main Wire and Instrument Panel J/B (Cowl Side Left)        |
| ID   | 30       |  |
| IF   | 31       | Instrument Panel Wire and Instrument Panel J/B (Cowl Side Left)        |
| IG   |          |  |
| II   |          |  |

 : Connector Joining Wire Harness and Wire Harness

| Code | See Page    | Joining Wire Harness and Wire Harness (Connector Location)                                |
|------|-------------|---|
| AE5  | 66          | Engine Room Main Wire and Instrument Panel Wire (Instrument Panel Right)                  |
| AE6  |             |   |
| AE7  | 66          | Engine Room Main Wire and Instrument Panel Wire (Right Side of the Instrument Panel J/B)  |
| CA1  | 64 (2GR-FE) | Engine Wire and Engine Room Main Wire (Inside of the Engine Room R/B and Engine Room J/B) |
| CA2  |             |   |
| CA3  |             |   |
| CV1  | 64 (2GR-FE) | Engine Wire and Sensor Wire (Left Side of the Cylinder Block)                             |
| EA1  | 66          | Instrument Panel Wire and Engine Room Main Wire (Left Kick Panel)                         |
| FE3  | 66          | Instrument Panel No.2 Wire and Instrument Panel Wire (Instrument Panel Center)            |
| NA1  | 66          | Floor Wire and Engine Room Main Wire (Left Kick Panel)                                    |

## Engine Control for 2GR-FE

---



: Ground Points

| Code | See Page    | Ground Points Location           |
|------|-------------|----------------------------------|
| A1   | 64 (2GR-FE) | Front Left Fender                |
| A2   |             |                                  |
| A3   | 66          | Left Cowl Side Panel             |
| C4   | 64 (2GR-FE) | Cylinder Head                    |
| C5   | 64 (2GR-FE) | Right Side of the Cylinder Block |
| C7   | 64 (2GR-FE) | Left Side of the Cylinder Block  |
| F1   | 66          | Instrument Panel Left            |
| N1   | 67          | Left Rear Quarter Panel          |



# Engine Control for 2AZ-FE

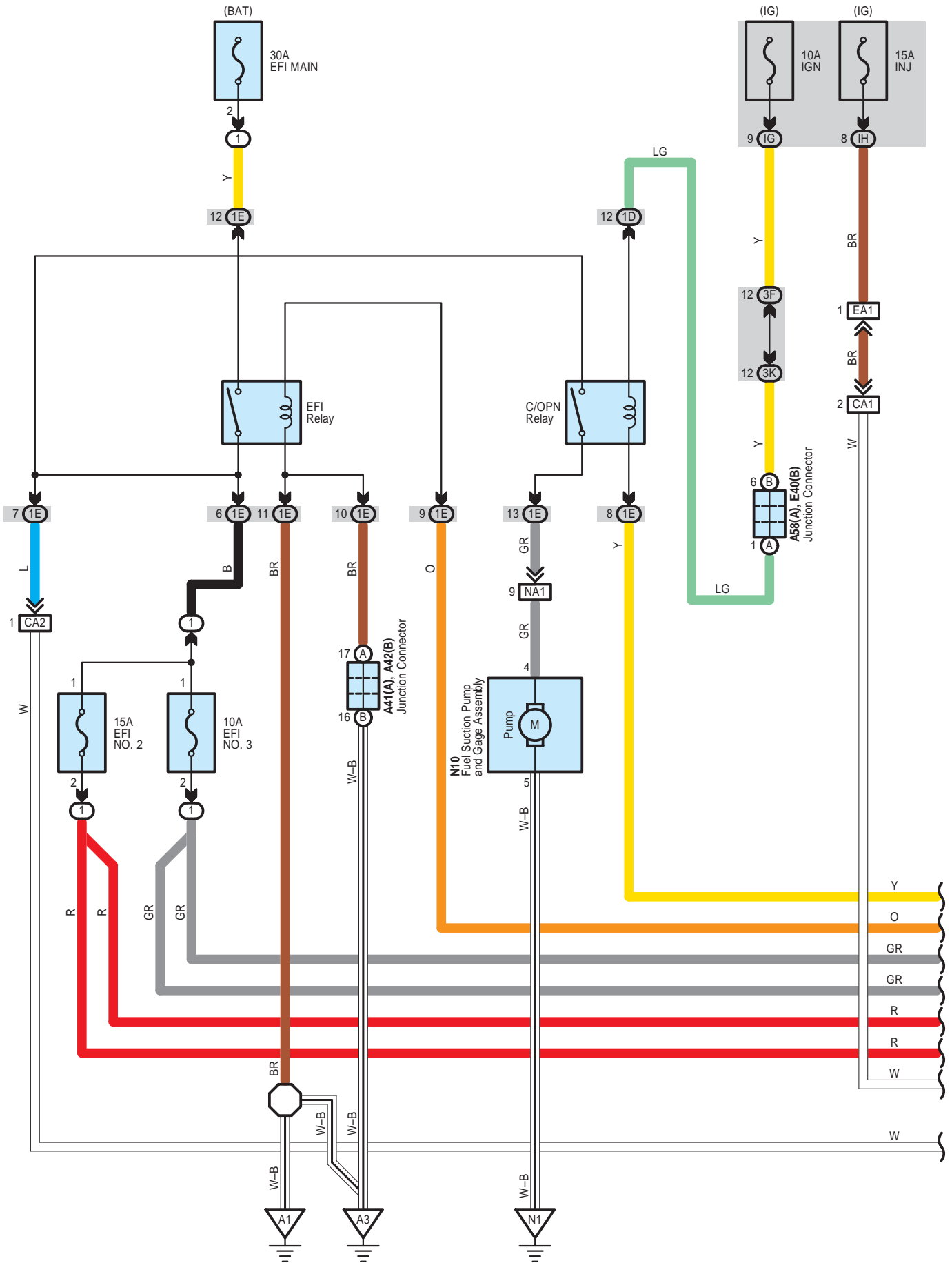

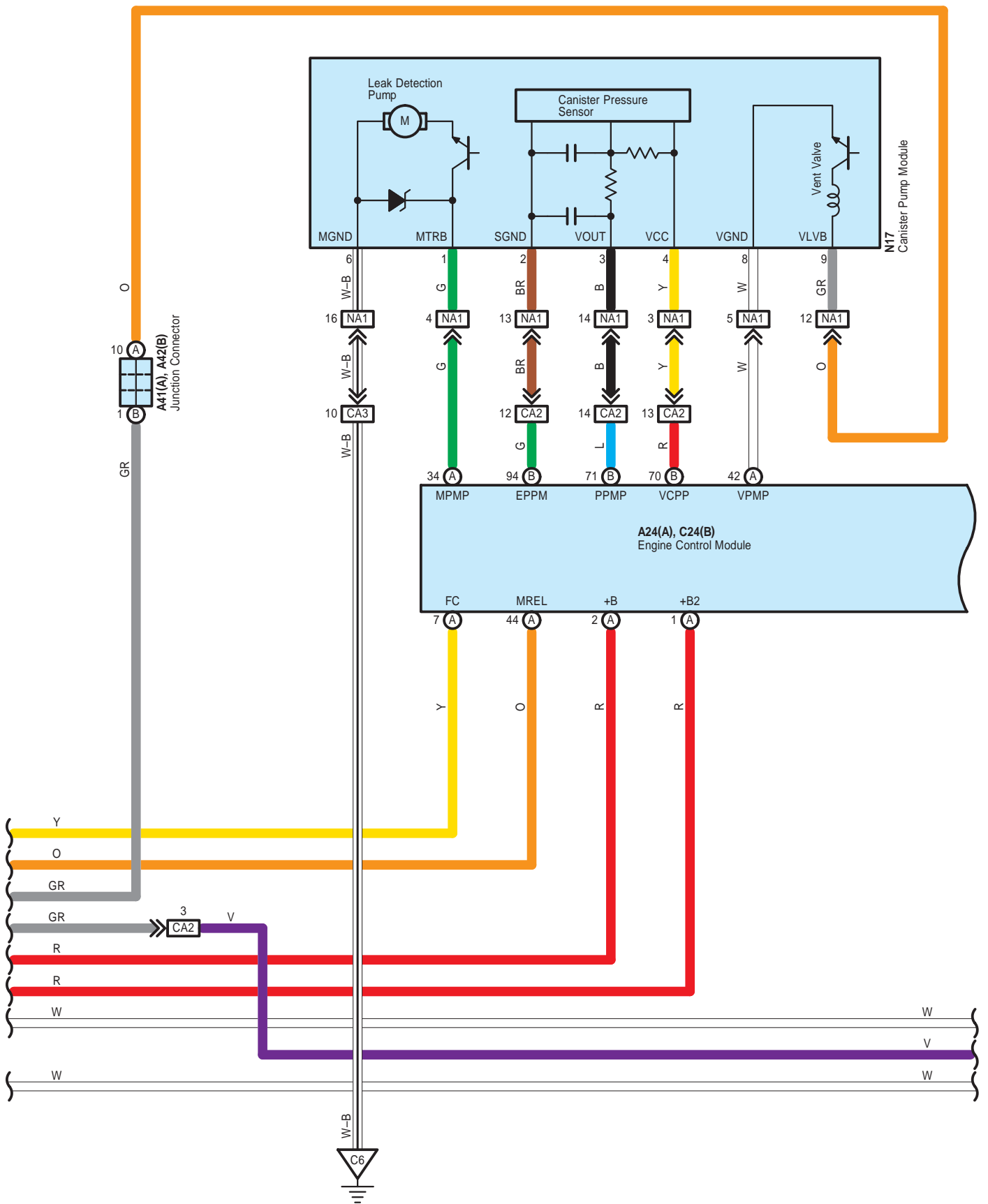



# Engine Control for 2AZ-FE

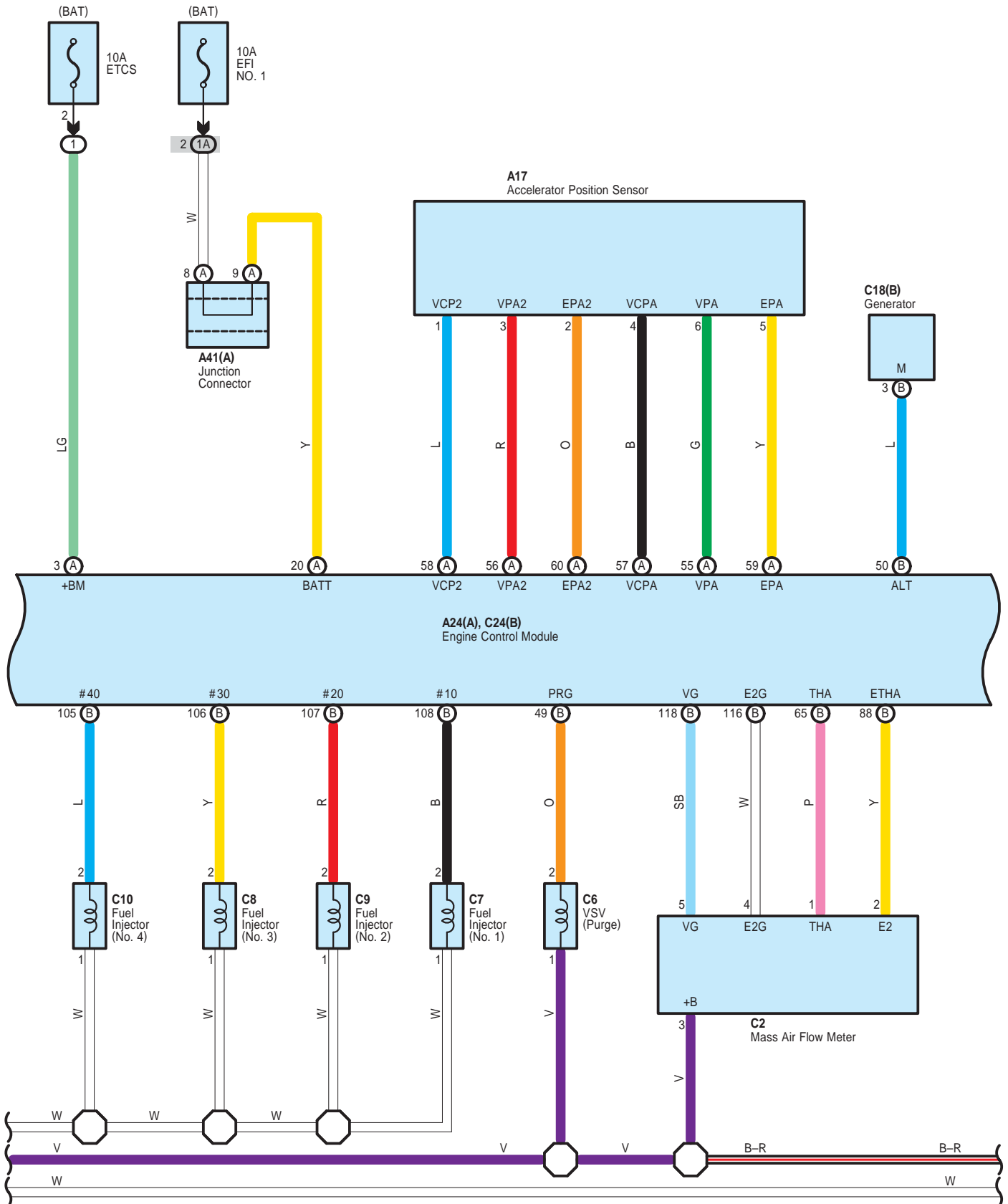

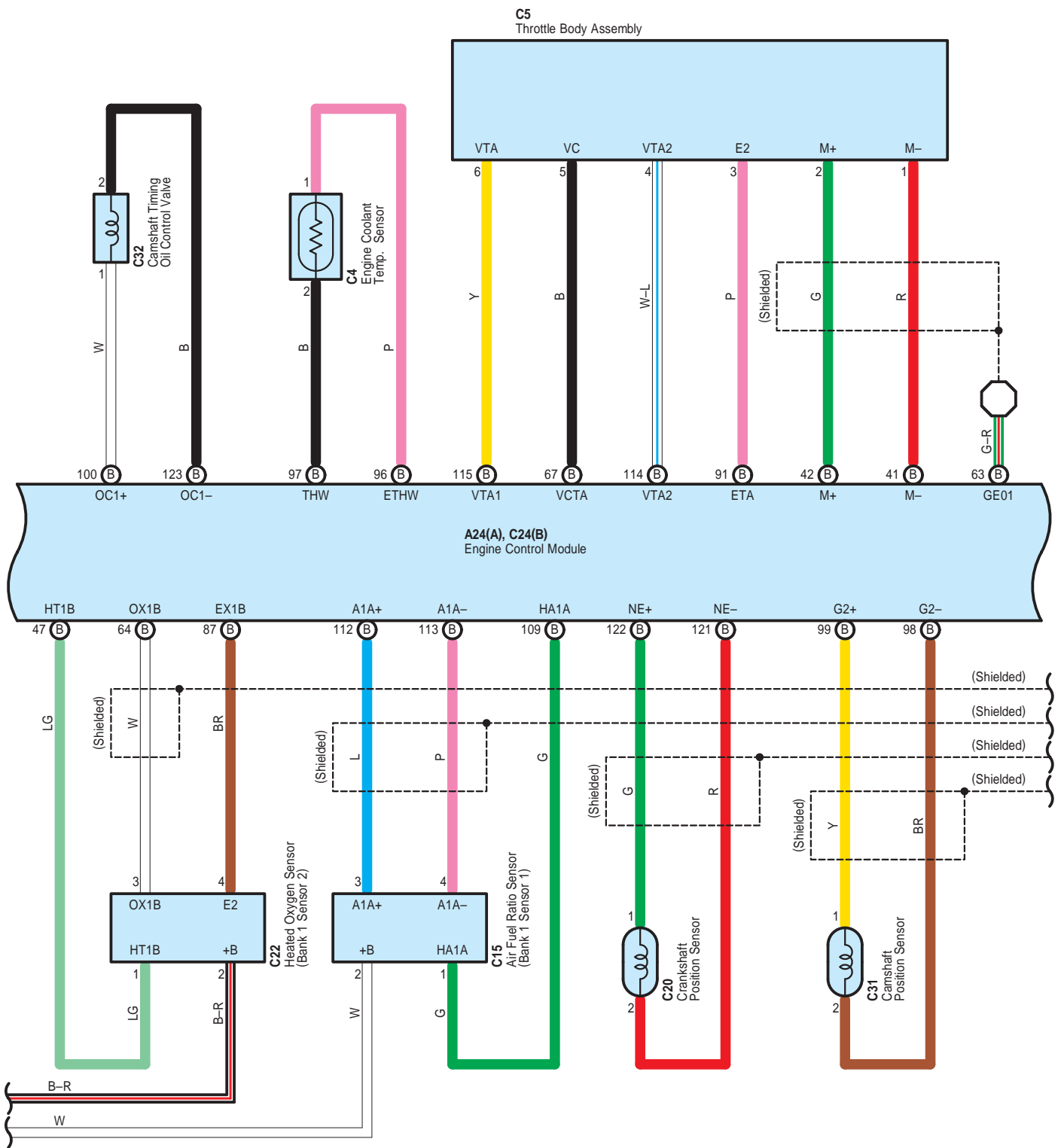

# Engine Control for 2AZ-FE

\* 1 : California

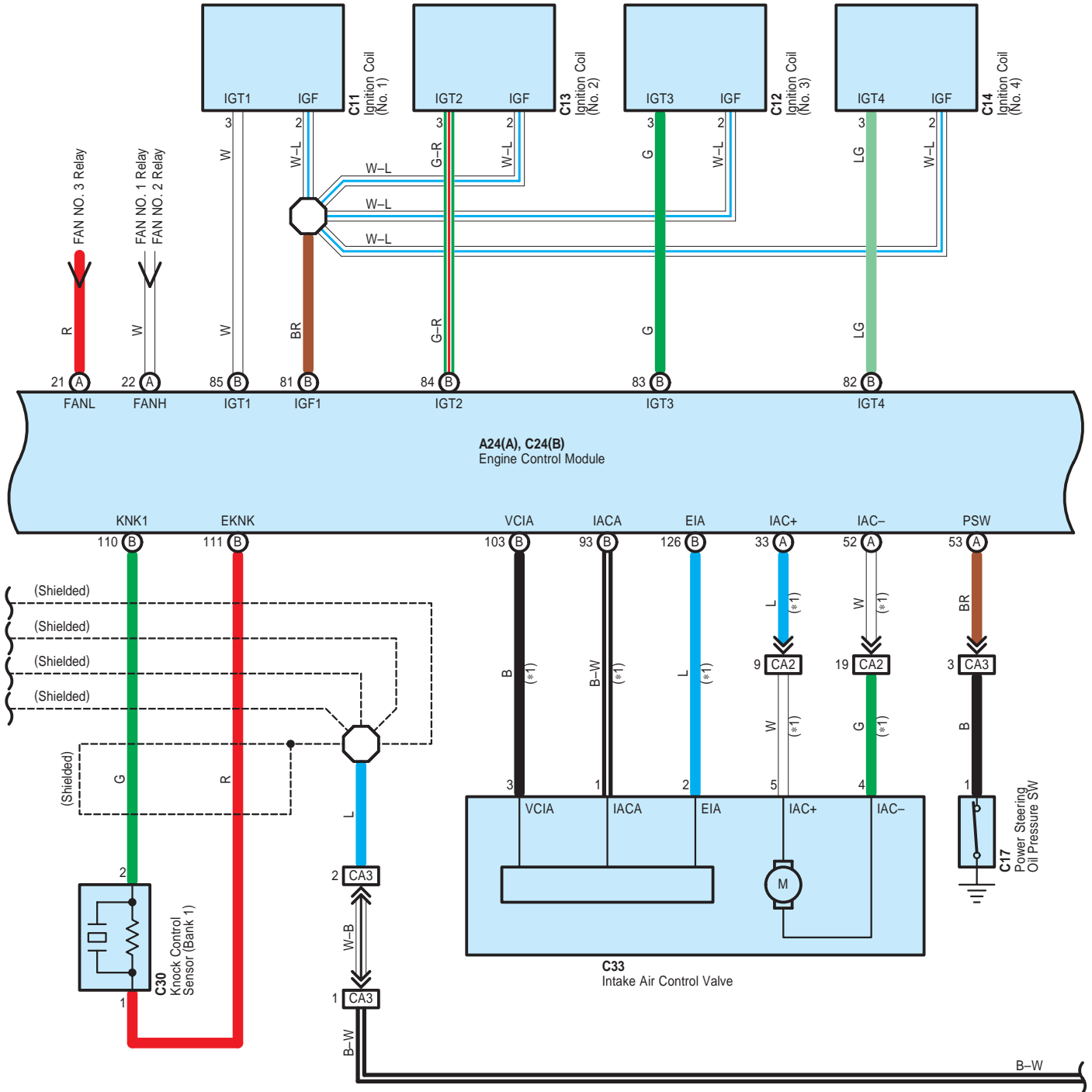

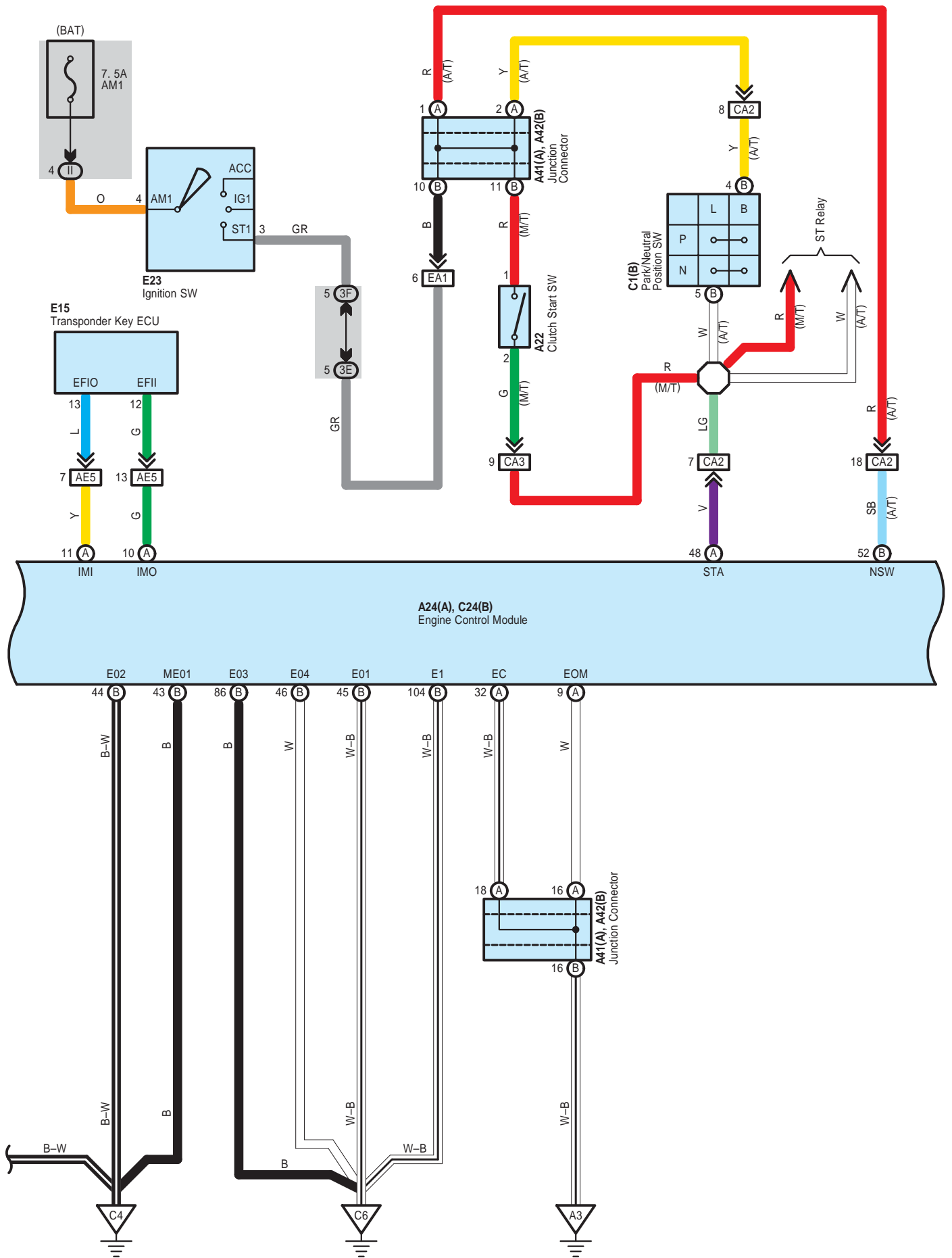

# Engine Control for 2AZ-FE

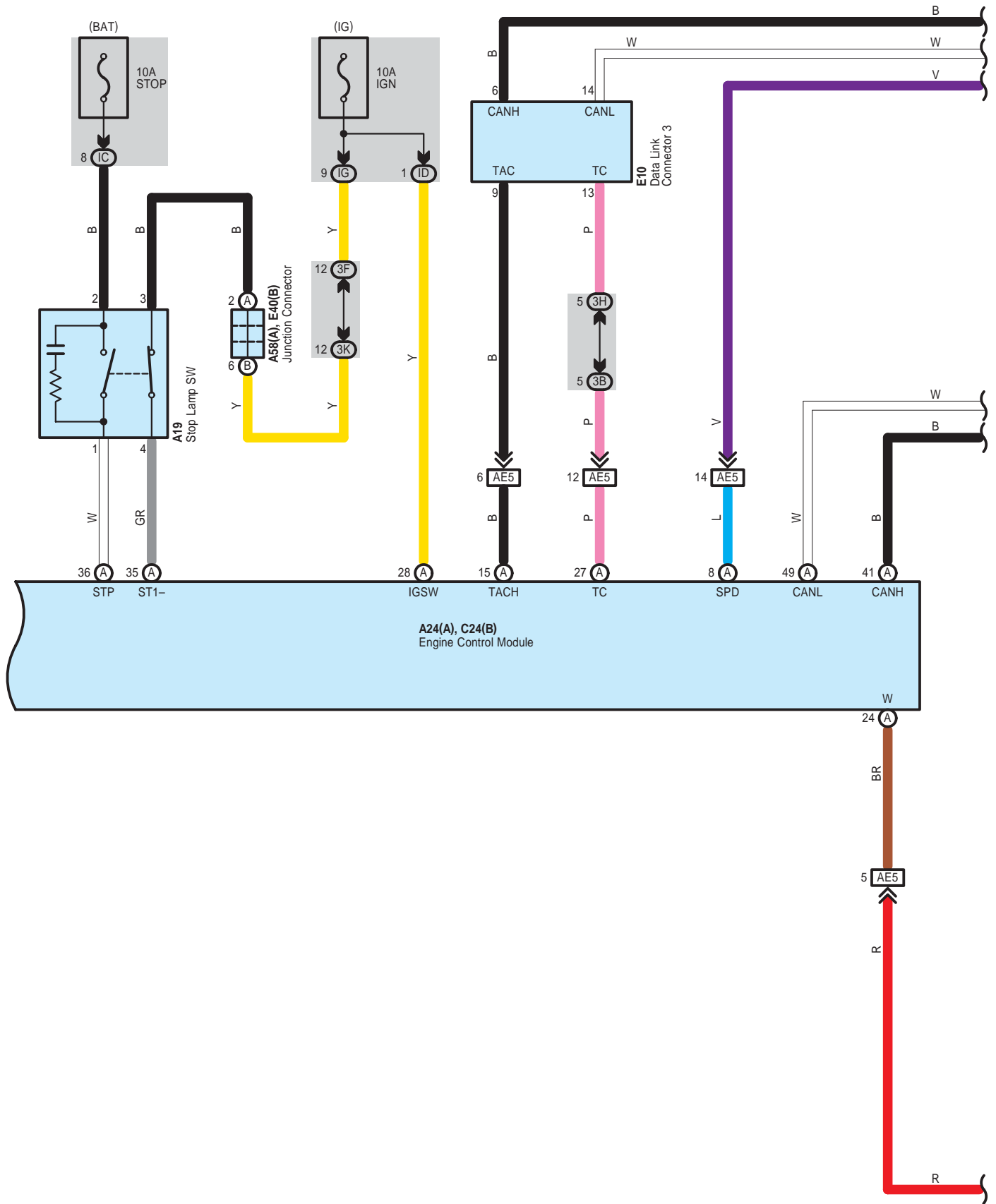

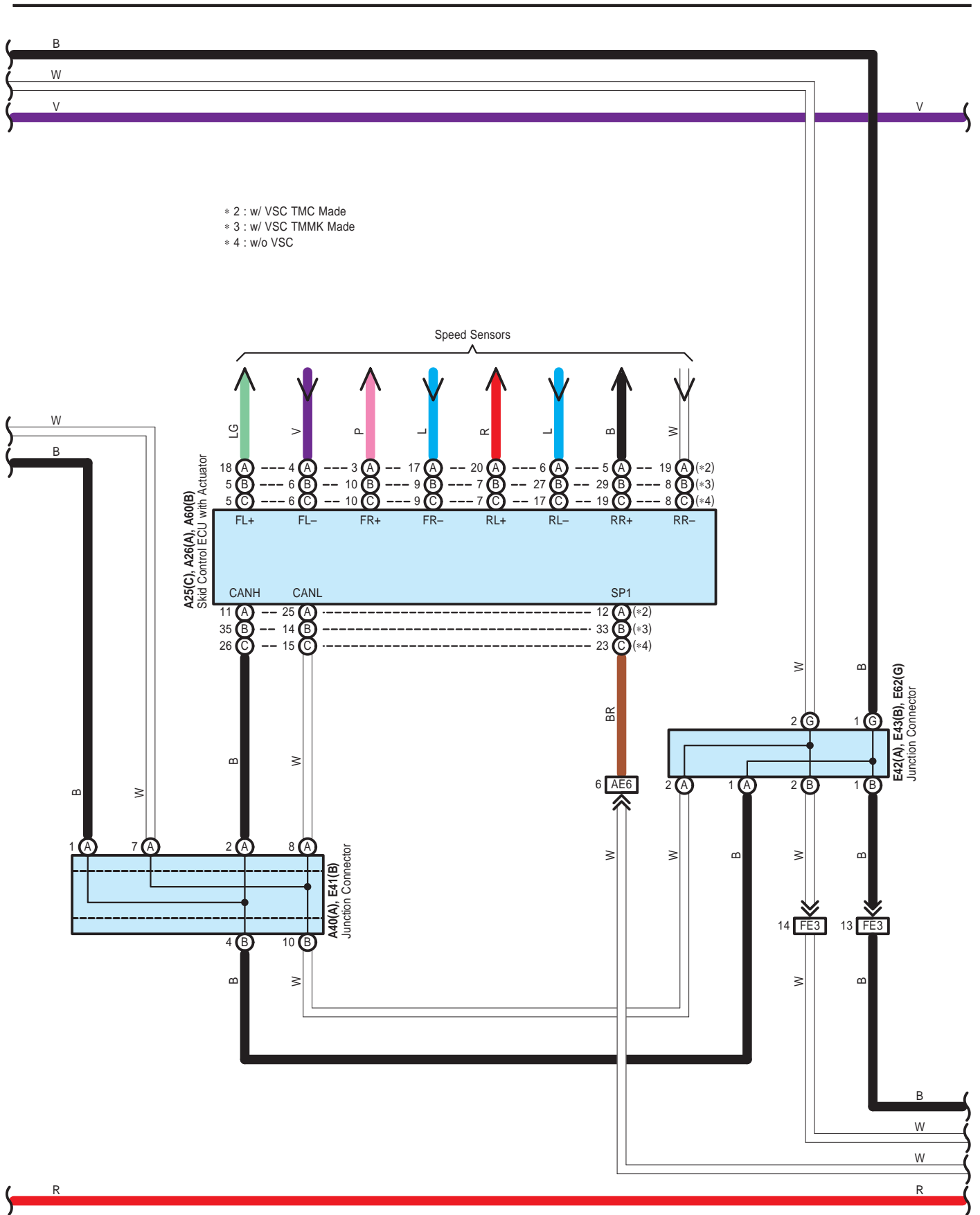

# Engine Control for 2AZ-FE

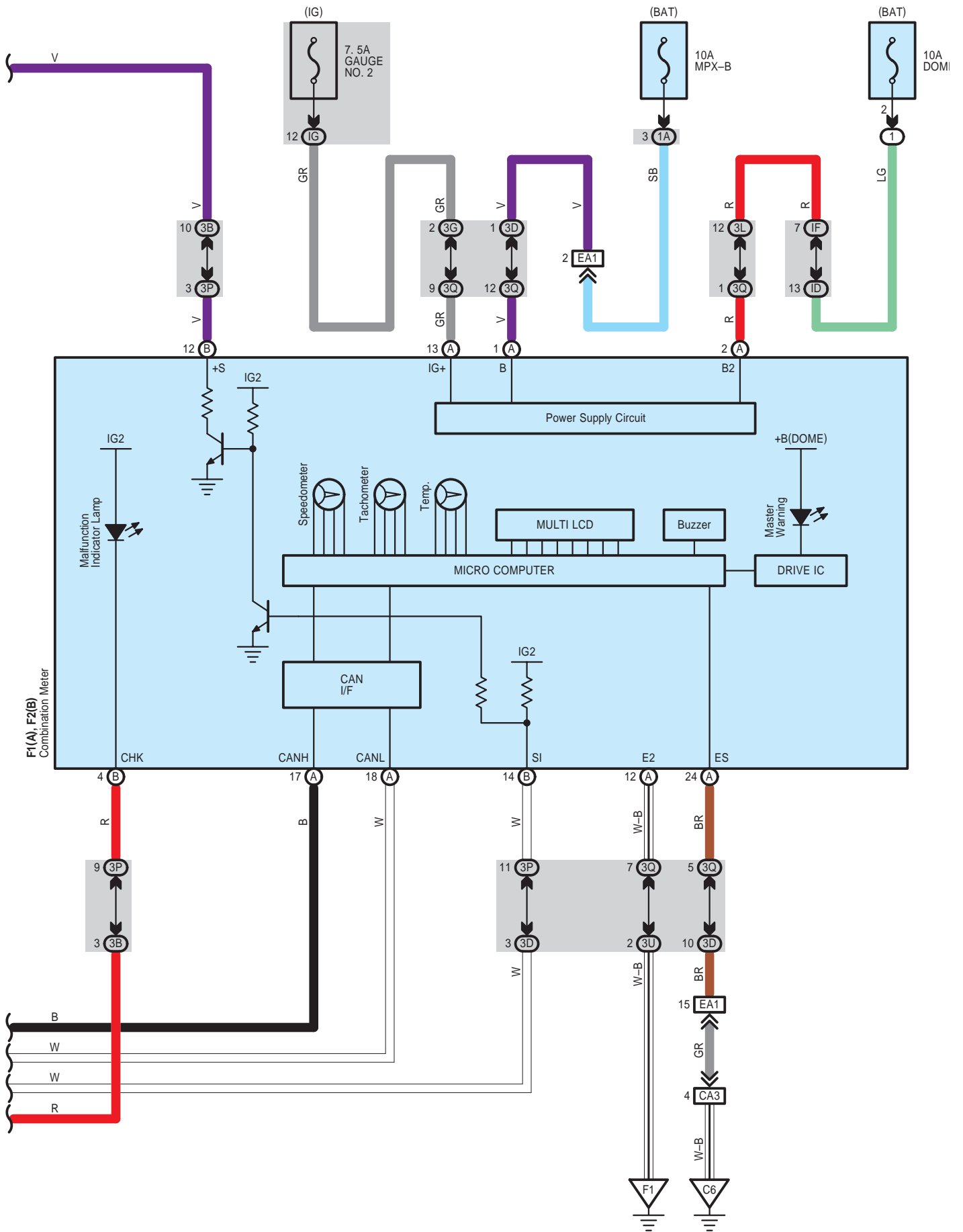

## System Outline

The engine control system utilizes a microcomputer and maintains overall control of the engine, transaxle etc. An outline of the engine control is given here.

### 1. Input Signals

- (1) Engine coolant temp. signal circuit  
The engine coolant temp. sensor detects the engine coolant temp. and has a built-in thermistor with a resistance, which varies according to the engine coolant temp.. The engine coolant temp. which is input into TERMINAL THW of the engine control module as a control signal.
- (2) Intake air temp. signal circuit  
The intake air temp. sensor is installed in the mass air flow meter and detects the intake air temp. which is input as a control signal to TERMINAL THA of the engine control module.
- (3) Oxygen density signal circuit  
The oxygen density in the exhaust emission is detected by the heated oxygen sensor and input as a control signal to TERMINAL OX1B of the engine control module.
- (4) RPM signal circuit  
Camshaft position and crankshaft position are detected by the camshaft position sensor and crankshaft position sensor. Camshaft position is input as a control signal to TERMINAL G2+ of the engine control module, and engine RPM is input into TERMINAL NE+.
- (5) Throttle position signal circuit  
The throttle position sensor detects the throttle valve opening angle as a control signal, which is input into TERMINALS VTA1 and VTA2 of the engine control module.
- (6) Vehicle speed circuit  
The vehicle speed sensor, detects the vehicle speed and input to speed sensor of the skid control ECU with actuator, from skid control ECU with actuator to TERMINAL SPD of the engine control module, Via combination meter.
- (7) Battery signal circuit  
Voltage is constantly applied to TERMINAL BATT of the engine control module. With the ignition SW turned on, the voltage for engine control module start-up power supply is applied to TERMINALS +B and +B2 of the engine control module via the EFI relay.
- (8) Stop lamp SW signal circuit  
The stop lamp SW is used to detect whether the vehicle is braking or not and the signal is input into TERMINAL STP of the engine control module as a control signal.
- (9) Starter signal circuit  
To confirm whether the engine is cranking, the voltage is applied to the starter motor during cranking is detected and the signal is input into TERMINAL STA of the engine control module as a control signal.
- (10) Engine knock signal circuit  
Engine knocking is detected by knock sensor and the signal is input into TERMINAL KNK1 as a control signal.
- (11) Air fuel ratio signal system  
The air fuel ratio is detected and input as a control signal into TERMINAL A1A+ of the engine control module.



# Engine Control for 2AZ-FE

## 2. Control System

### \* SFI system

The SFI system monitors the engine condition through the signals input from each sensor to the engine control module. And the control signal is output to TERMINALS #10, #20, #30, #40 of the engine control module to operate the fuel injector (Inject the fuel). The SFI system controls the fuel injection operation by the engine control module in response to the driving conditions.

### \* ESA system

The ESA system monitors the engine condition through the signals input to the engine control module from each sensor. The best ignition timing is decided according to this data and the memorized data in the engine control module and the control signal is output to TERMINALS IGT1, IGT2, IGT3, IGT4. This signal controls the igniter to provide the best ignition timing for the driving conditions.

### \* Heated oxygen sensor heater control system

The heated oxygen sensor heater control system turns the heater on when the intake air volume is low (Temp. of exhaust emissions is low), and warms up the heated oxygen sensor to improve detection performance of the sensor. The engine control module evaluates the signals from each sensor, and outputs current to TERMINAL HT1B to control the heater.

## 3. Diagnosis System

With the diagnosis system, when there is a malfunction in the engine control module signal system, the malfunctioning system is recorded in the memory. The malfunctioning system can be found by reading the code displayed by the malfunction indicator lamp.

## 4. Fail-Safe System

When a malfunction has occurred in any system, if there is a possibility of engine trouble being caused by continued control based on the signals from that system, the fail-safe system either controls the system by using data (Standard values) recorded in the engine control module memory or else stops the engine.

### ○ : Parts Location

| Code | See Page      | Code | See Page      | Code | See Page    |
|------|---------------|------|---------------|------|-------------|
| A17  | 59            | C7   | 54 (2AZ-FE)   | C32  | 55 (2AZ-FE) |
| A19  | 59            | C8   | 54 (2AZ-FE)   | C33  | 55 (2AZ-FE) |
| A22  | 59            | C9   | 54 (2AZ-FE)   | E10  | 56          |
| A24  | A 52 (2AZ-FE) | C10  | 54 (2AZ-FE)   | E15  | 56          |
| A25  | C 52 (2AZ-FE) | C11  | 54 (2AZ-FE)   | E23  | 56          |
| A26  | A 52 (2AZ-FE) | C12  | 54 (2AZ-FE)   | E40  | B 57        |
| A40  | A 59          | C13  | 54 (2AZ-FE)   | E41  | B 57        |
| A41  | A 59          | C14  | 54 (2AZ-FE)   | E42  | A 57        |
| A42  | B 59          | C15  | 54 (2AZ-FE)   | E43  | B 57        |
| A58  | A 59          | C17  | 54 (2AZ-FE)   | E62  | G 57        |
| A60  | B 53 (2AZ-FE) | C18  | B 54 (2AZ-FE) | F1   | A 58        |
| C1   | B 54 (2AZ-FE) | C20  | 55 (2AZ-FE)   | F2   | B 58        |
| C2   | 54 (2AZ-FE)   | C22  | 55 (2AZ-FE)   | N10  | 60          |
| C4   | 54 (2AZ-FE)   | C24  | B 55 (2AZ-FE) | N17  | 60          |
| C5   | 54 (2AZ-FE)   | C30  | 55 (2AZ-FE)   |      |             |
| C6   | 54 (2AZ-FE)   | C31  | 55 (2AZ-FE)   |      |             |

### ○ : Relay Blocks

| Code | See Page | Relay Blocks (Relay Block Location)       |
|------|----------|---|
| 1    | 22       | Engine Room R/B (Engine Compartment Left) |

 : Junction Block and Wire Harness Connector

| Code | See Page | Junction Block and Wire Harness (Connector Location)                   |
|------|----------|--|
| 1A   | 25       | Engine Room Main Wire and Engine Room J/B (Engine Compartment Left)    |
| 1D   |          |  |
| 1E   |          |  |
| 3B   | 36       | Instrument Panel Wire and J/B No.3 (Behind the Combination Meter)      |
| 3D   |          |  |
| 3E   |          |  |
| 3F   |          |  |
| 3G   |          |  |
| 3H   |          |  |
| 3K   |          |  |
| 3L   |          |  |
| 3P   | 36       | Instrument Panel No.2 Wire and J/B No.3 (Behind the Combination Meter) |
| 3Q   |          |  |
| 3U   |          |  |
| IC   | 30       | Engine Room Main Wire and Instrument Panel J/B (Cowl Side Left)        |
| ID   |          |  |
| IF   | 30       | Instrument Panel Wire and Instrument Panel J/B (Cowl Side Left)        |
| IG   | 31       |  |
| IH   |          |  |
| II   |          |  |

 : Connector Joining Wire Harness and Wire Harness

| Code | See Page    | Joining Wire Harness and Wire Harness (Connector Location)                                |
|------|-------------|---|
| AE5  | 66          | Engine Room Main Wire and Instrument Panel Wire (Instrument Panel Right)                  |
| AE6  |             |   |
| CA1  | 65 (2AZ-FE) | Engine Wire and Engine Room Main Wire (Inside of the Engine Room R/B and Engine Room J/B) |
| CA2  |             |   |
| CA3  |             |   |
| EA1  | 66          | Instrument Panel Wire and Engine Room Main Wire (Left Kick Panel)                         |
| FE3  | 66          | Instrument Panel No.2 Wire and Instrument Panel Wire (Instrument Panel Center)            |
| NA1  | 66          | Floor Wire and Engine Room Main Wire (Left Kick Panel)                                    |

 : Ground Points

| Code | See Page    | Ground Points Location  |
|------|-------------|-------------------------|
| A1   | 65 (2AZ-FE) | Front Left Fender       |
| A3   | 66          | Left Cowl Side Panel    |
| C4   | 65 (2AZ-FE) | Cylinder Block          |
| C6   |             |                         |
| F1   | 66          | Instrument Panel Left   |
| N1   | 67          | Left Rear Quarter Panel |

# Engine Immobiliser System without Smart Key System

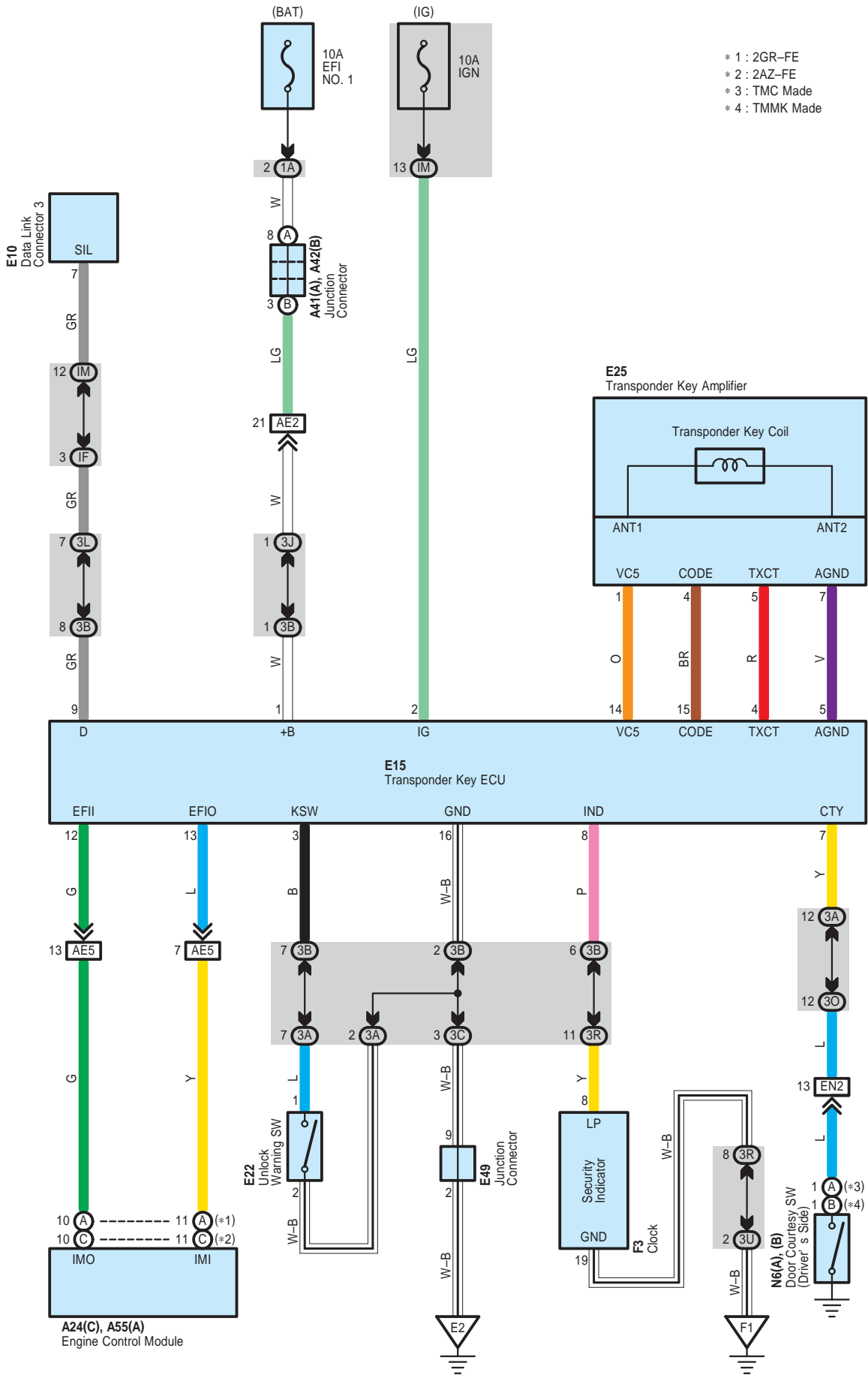

- \* 1 : 2GR-FE
- \* 2 : 2AZ-FE
- \* 3 : TMC Made
- \* 4 : TMMK Made

 : **Parts Location**

| Code |   | See Page    | Code |    | See Page | Code |    | See Page |
|------|---|-------------|------|----|----------|------|----|----------|
| A24  | C | 52 (2AZ-FE) | E10  | 56 | E49      | 57   |    |          |
| A41  | A | 59          | E15  | 56 | F3       | 58   |    |          |
| A42  | B | 59          | E22  | 56 | N6       | A    | 60 |          |
| A55  | A | 49 (2GR-FE) | E25  | 56 |          | B    | 60 |          |

 : **Junction Block and Wire Harness Connector**

| Code | See Page | Junction Block and Wire Harness (Connector Location)                   |
|------|----------|--|
| 1A   | 25       | Engine Room Main Wire and Engine Room J/B (Engine Compartment Left)    |
| 3A   | 36       | Instrument Panel Wire and J/B No.3 (Behind the Combination Meter)      |
| 3B   |          |  |
| 3C   |          |  |
| 3J   |          |  |
| 3L   |          |  |
| 3O   |          |  |
| 3R   | 36       | Instrument Panel No.2 Wire and J/B No.3 (Behind the Combination Meter) |
| 3U   |          |  |
| IF   | 30       | Instrument Panel Wire and Instrument Panel J/B (Cowl Side Left)        |
| IM   |          |  |

 : **Connector Joining Wire Harness and Wire Harness**

| Code | See Page | Joining Wire Harness and Wire Harness (Connector Location)                               |
|------|----------|--|
| AE2  | 68       | Engine Room Main Wire and Instrument Panel Wire (Right Side of the Instrument Panel J/B) |
| AE5  | 66       | Engine Room Main Wire and Instrument Panel Wire (Instrument Panel Right)                 |
| EN2  | 66       | Instrument Panel Wire and Floor Wire (Left Kick Panel)                                   |

 : **Ground Points**

| Code | See Page | Ground Points Location    |
|------|----------|---------------------------|
| E2   | 66       | Instrument Panel Brace LH |
| F1   | 66       | Instrument Panel Left     |

# Data Link Connector 3

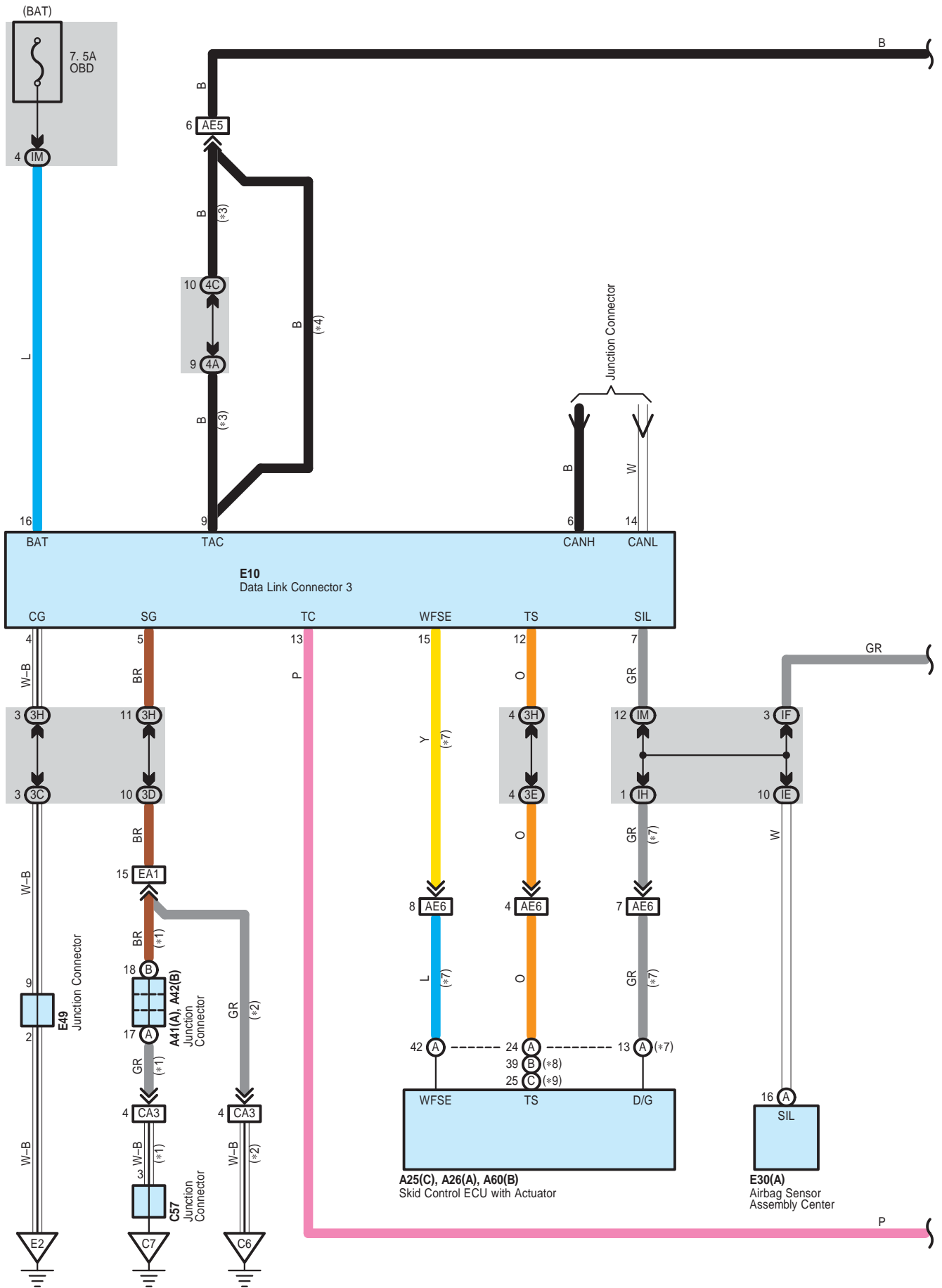

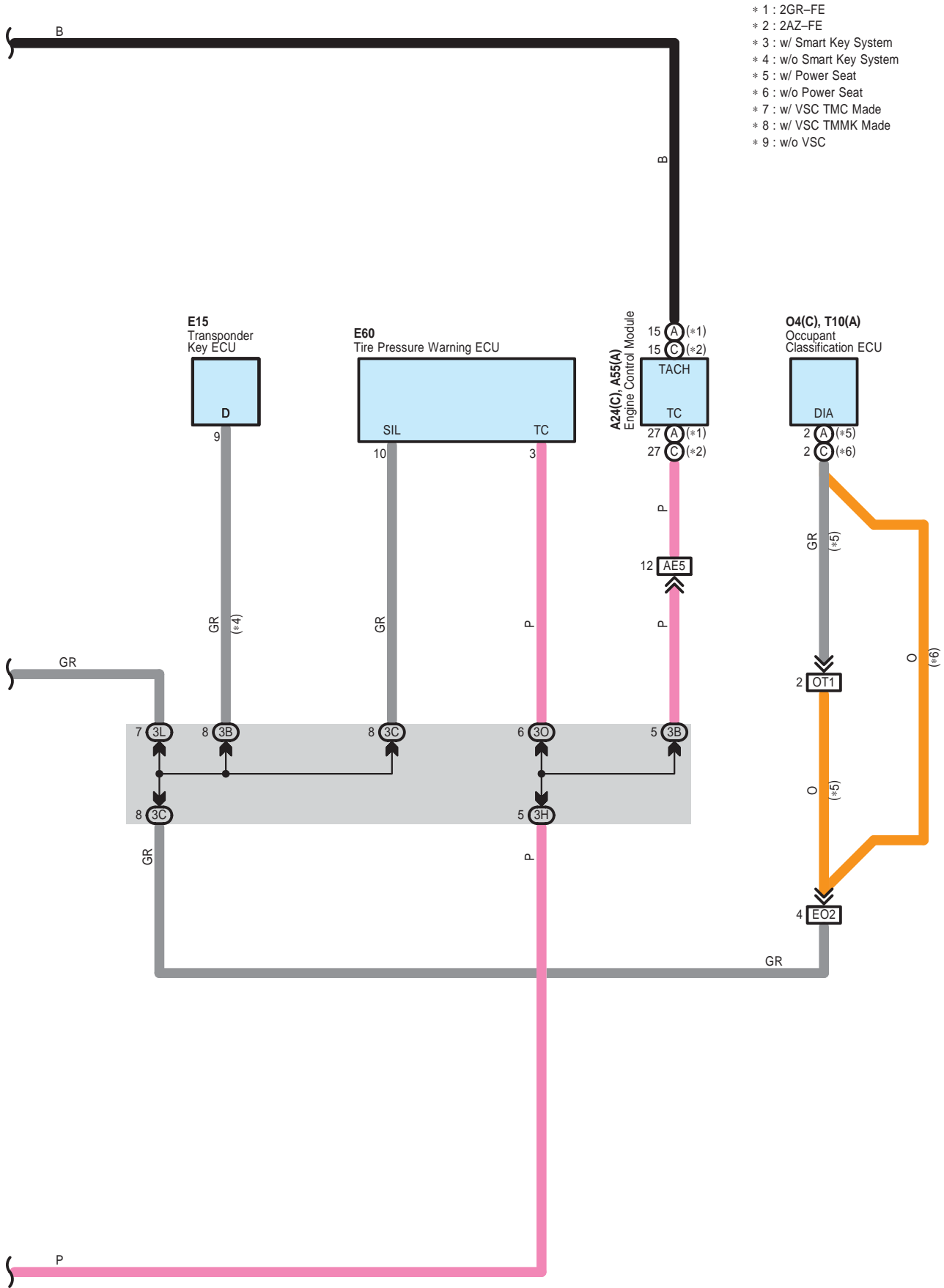

CAMRY (EM0250U)

# Data Link Connector 3

## ○ : Parts Location

| Code |   | See Page    | Code |             | See Page    | Code |     | See Page |
|------|---|-------------|------|-------------|-------------|------|-----|----------|
| A24  | C | 52 (2AZ-FE) | A42  | B           | 59          | E15  | 56  |          |
| A25  | C | 48 (2GR-FE) | A55  | A           | 49 (2GR-FE) | E30  | A   | 56       |
|      |   | 52 (2AZ-FE) | A60  | B           | 49 (2GR-FE) | E49  | 57  |          |
| A26  | A | 48 (2GR-FE) |      |             |             |      | E60 | 57       |
|      |   | 52 (2AZ-FE) | C57  | 51 (2GR-FE) |             | O4   | C   | 63 (*2)  |
| A41  | A | 59          | E10  | 56          |             | T10  | A   | 62 (*1)  |

## ○ : Junction Block and Wire Harness Connector

| Code | See Page | Junction Block and Wire Harness (Connector Location)               |    |
|------|----------|--|----|
| 3B   | 36       | Instrument Panel Wire and J/B No.3 (Behind the Combination Meter)  |    |
| 3C   |          |  |    |
| 3D   |          |  |    |
| 3E   |          |  |    |
| 3H   |          |  |    |
| 3L   |          |  |    |
| 3O   |          |  |    |
| 4A   | 42       | Instrument Panel Wire and J/B No.4 (Instrument Panel Brace Center) |    |
| 4C   |          |  |    |
| IE   | 30       | Instrument Panel Wire and Instrument Panel J/B (Cowl Side Left)    |    |
| IF   |          |  |    |
| IH   |          |  | 31 |
| IM   |          |  | 30 |

## □ : Connector Joining Wire Harness and Wire Harness

| Code | See Page    | Joining Wire Harness and Wire Harness (Connector Location)                                |
|------|-------------|---|
| AE5  | 66          | Engine Room Main Wire and Instrument Panel Wire (Instrument Panel Right)                  |
| AE6  |             |   |
| CA3  | 64 (2GR-FE) | Engine Wire and Engine Room Main Wire (Inside of the Engine Room R/B and Engine Room J/B) |
|      | 65 (2AZ-FE) |   |
| EA1  | 66          | Instrument Panel Wire and Engine Room Main Wire (Left Kick Panel)                         |
| EO2  | 66          | Instrument Panel Wire and Floor No.2 Wire (Right Kick Panel)                              |
| OT1  | 68 (*1)     | Floor No.2 Wire and Front Seat RH Wire (Under the Front Passenger's Seat)                 |

## ▽ : Ground Points

| Code | See Page    | Ground Points Location          |
|------|-------------|---------------------------------|
| C6   | 65 (2AZ-FE) | Cylinder Block                  |
| C7   | 64 (2GR-FE) | Left Side of the Cylinder Block |
| E2   | 66          | Instrument Panel Brace LH       |

\* 1 : w/ Power Seat      \* 2 : w/o Power Seat





# Headlight

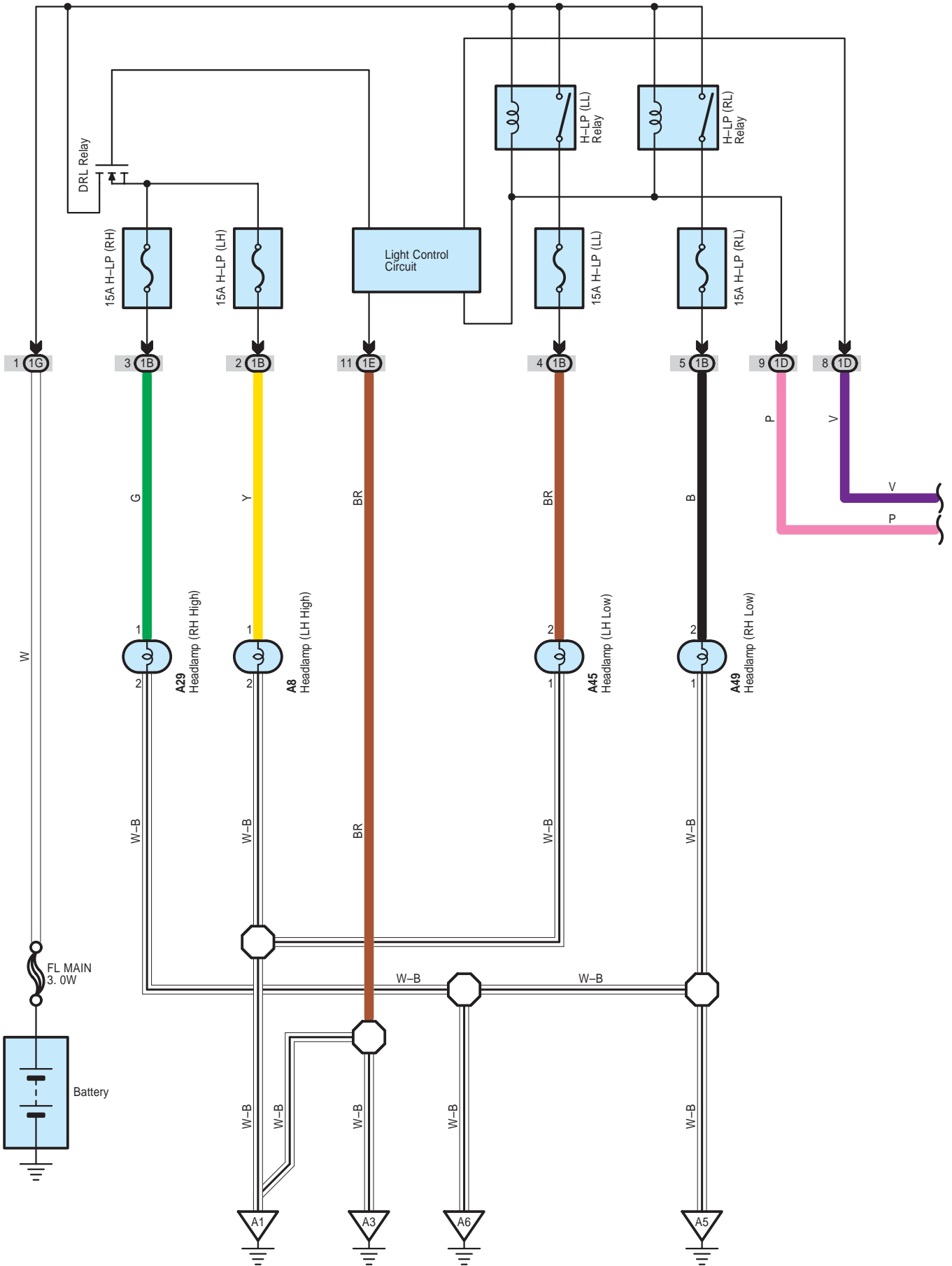

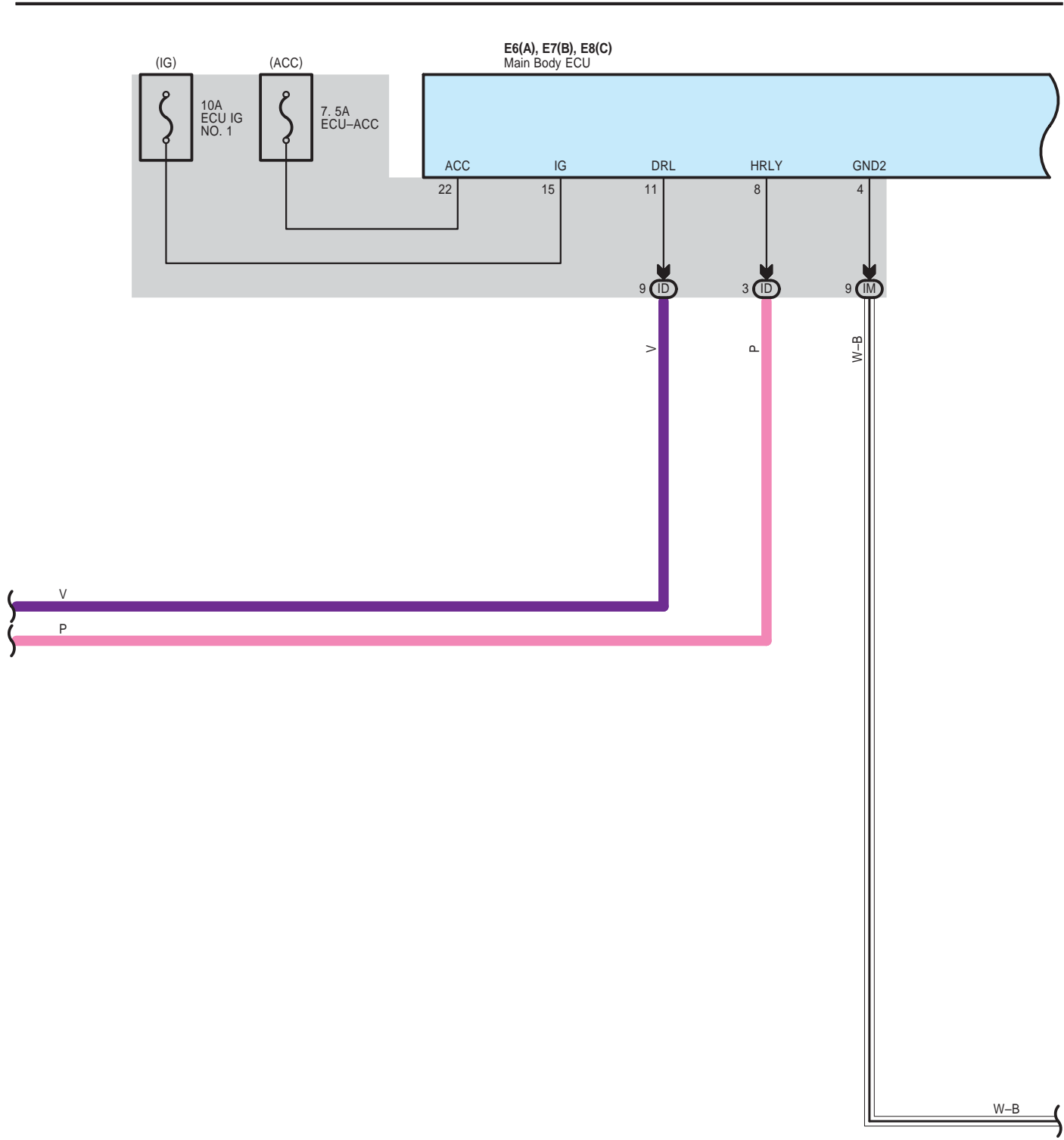

# Headlight

E6(A), E7(B), E8(C)  
Main Body ECU

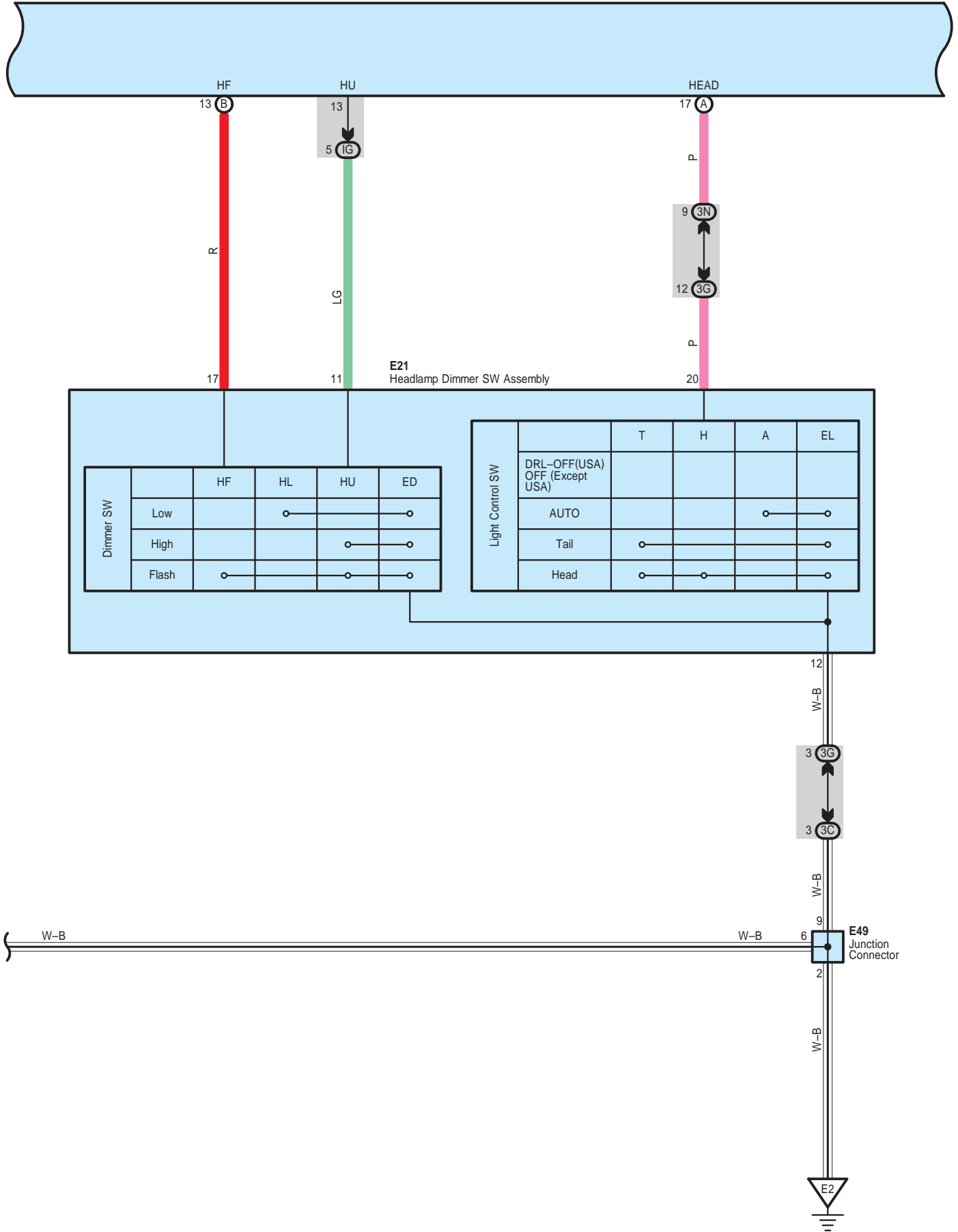

E6(A), E7(B), E8(C)  
Main Body ECU

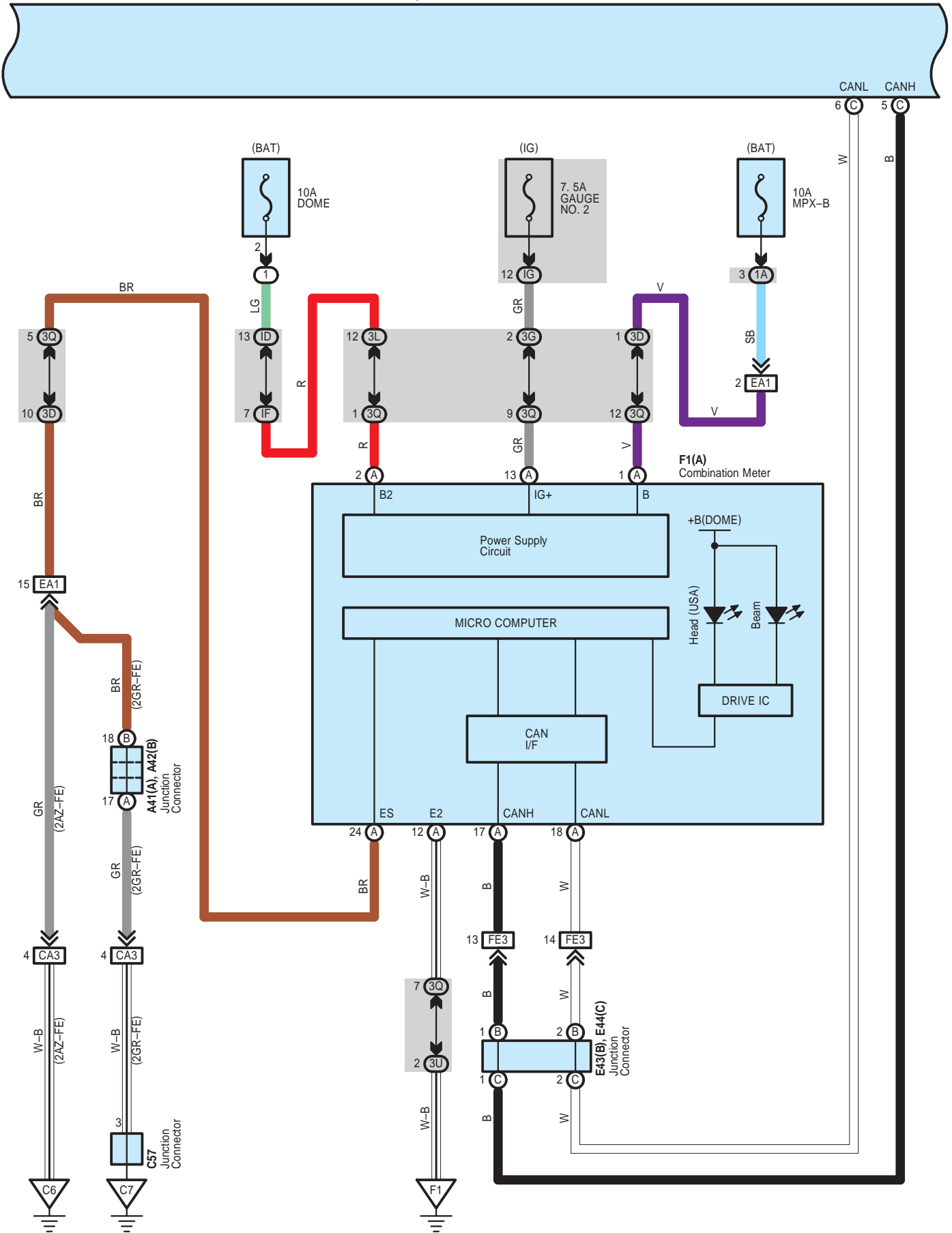

# Headlight

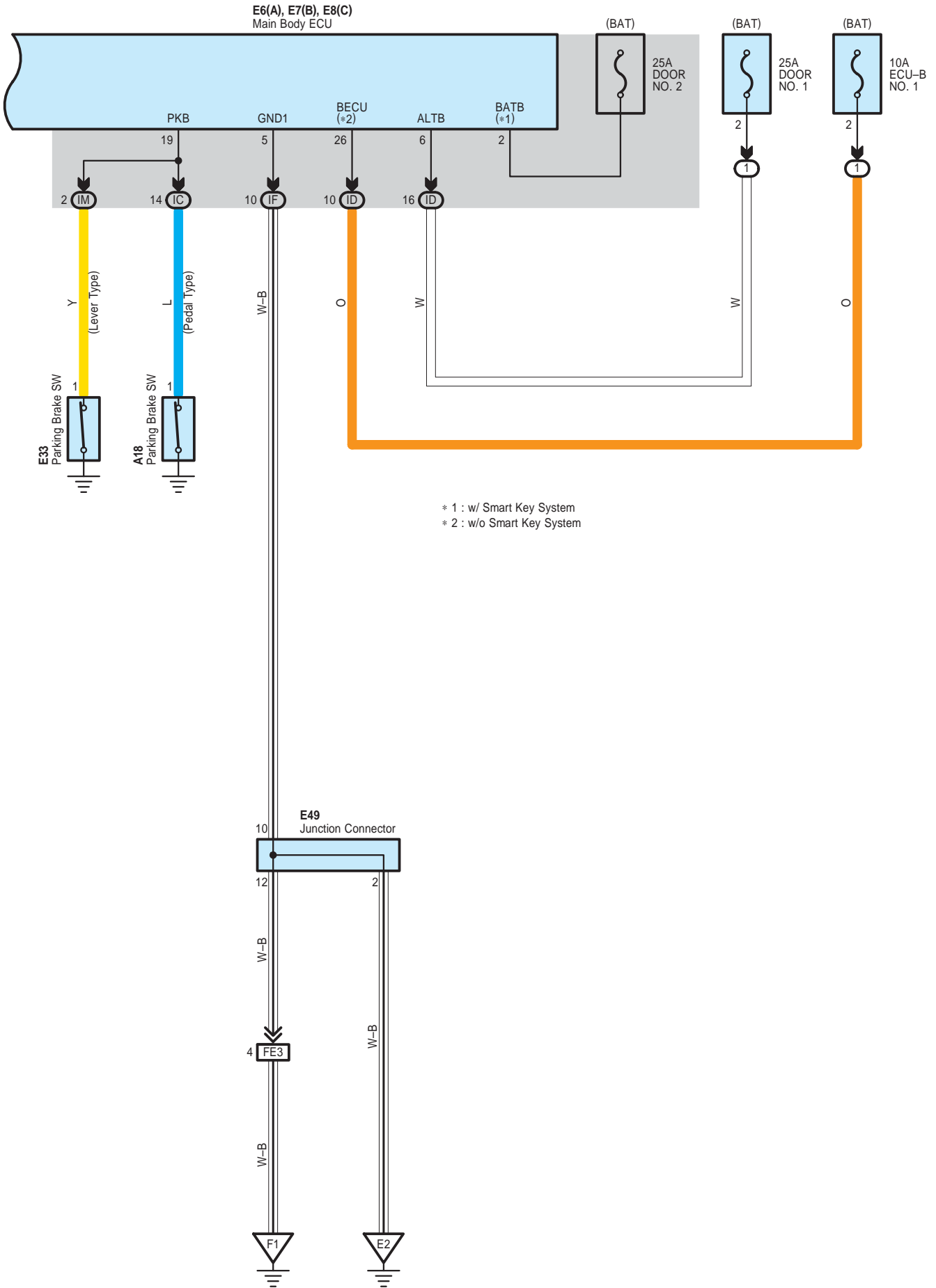

 : Parts Location

| Code |             | See Page | Code |             | See Page | Code |    | See Page |
|------|-------------|----------|------|-------------|----------|------|----|----------|
| A8   | 48 (2GR-FE) |          | A45  | 49 (2GR-FE) |          | E8   | C  | 56       |
|      | 52 (2AZ-FE) |          |      | 53 (2AZ-FE) |          | E21  |    | 56       |
| A18  | 59          |          | A49  | 49 (2GR-FE) |          | E33  |    | 56       |
| A29  | 48 (2GR-FE) |          |      | 53 (2AZ-FE) |          | E43  | B  | 57       |
|      | 52 (2AZ-FE) |          | C57  | 51 (2GR-FE) |          | E44  | C  | 57       |
| A41  | A           | 59       | E6   | A           | E49      |      | 57 |          |
| A42  | B           | 59       | E7   | B           | F1       |      | A  | 58       |

 : Relay Blocks

| Code | See Page | Relay Blocks (Relay Block Location)       |
|------|----------|---|
| 1    | 22       | Engine Room R/B (Engine Compartment Left) |

 : Junction Block and Wire Harness Connector

| Code | See Page | Junction Block and Wire Harness (Connector Location)                   |
|------|----------|--|
| 1A   | 25       | Engine Room Main Wire and Engine Room J/B (Engine Compartment Left)    |
| 1B   |          |  |
| 1D   |          |  |
| 1E   |          |  |
| 1G   | 22       |  |
| 3C   | 36       | Instrument Panel Wire and J/B No.3 (Behind the Combination Meter)      |
| 3D   |          |  |
| 3G   |          |  |
| 3L   |          |  |
| 3N   |          |  |
| 3Q   | 36       | Instrument Panel No.2 Wire and J/B No.3 (Behind the Combination Meter) |
| 3U   |          |  |
| IC   | 30       | Engine Room Main Wire and Instrument Panel J/B (Cowl Side Left)        |
| ID   |          |  |
| IF   | 30       | Instrument Panel Wire and Instrument Panel J/B (Cowl Side Left)        |
| IG   | 31       |  |
| IM   | 30       |  |

 : Connector Joining Wire Harness and Wire Harness

| Code | See Page    | Joining Wire Harness and Wire Harness (Connector Location)                                |
|------|-------------|---|
| CA3  | 64 (2GR-FE) | Engine Wire and Engine Room Main Wire (Inside of the Engine Room R/B and Engine Room J/B) |
|      | 65 (2AZ-FE) |   |
| EA1  | 66          | Instrument Panel Wire and Engine Room Main Wire (Left Kick Panel)                         |
| FE3  | 66          | Instrument Panel No.2 Wire and Instrument Panel Wire (Instrument Panel Center)            |

 : Ground Points

| Code | See Page    | Ground Points Location          |
|------|-------------|---------------------------------|
| A1   | 64 (2GR-FE) | Front Left Fender               |
|      | 65 (2AZ-FE) |                                 |
| A3   | 66          | Left Cowl Side Panel            |
| A5   | 64 (2GR-FE) | Front Right Fender              |
|      | 65 (2AZ-FE) |                                 |
| A6   | 66          | Right Cowl Side Panel           |
| C6   | 65 (2AZ-FE) | Cylinder Block                  |
| C7   | 64 (2GR-FE) | Left Side of the Cylinder Block |
| E2   | 66          | Instrument Panel Brace LH       |
| F1   | 66          | Instrument Panel Left           |

# Fog Light

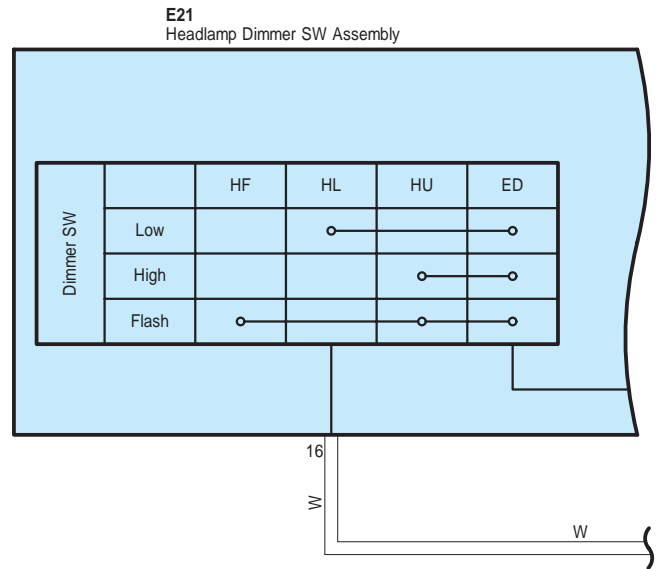
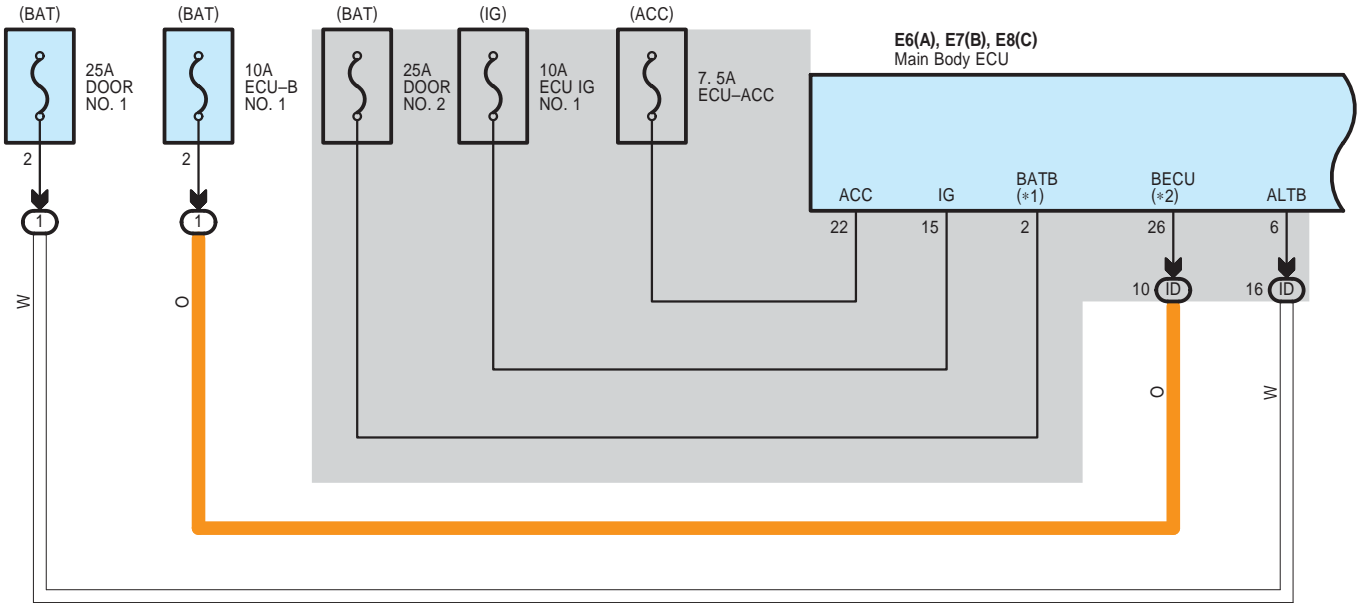

\* 1 : w/ Smart Key System  
 \* 2 : w/o Smart Key System

**E6(A), E7(B), E8(C)**  
 Main Body ECU

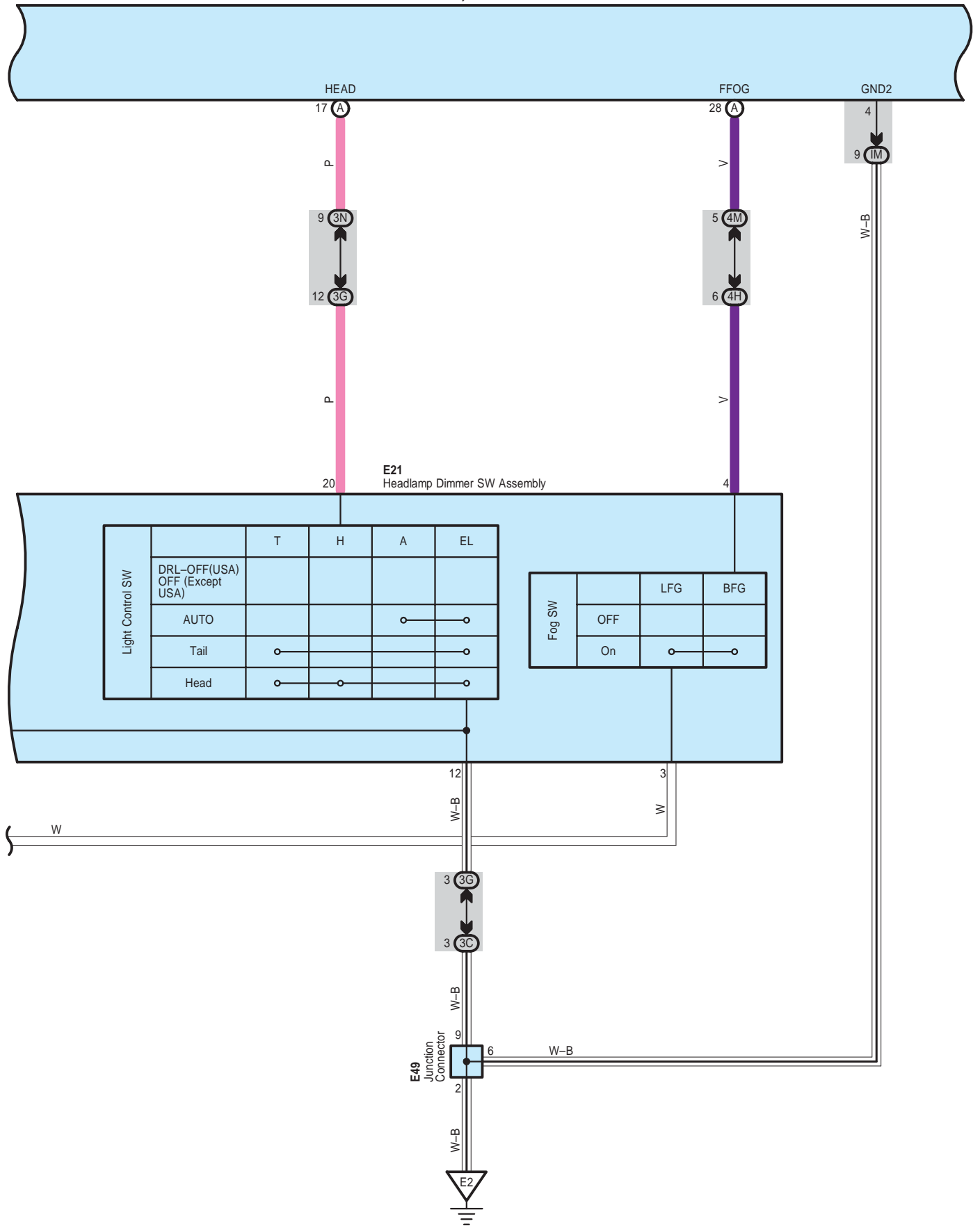



# Fog Light

E6(A), E7(B), E8(C)  
Main Body ECU

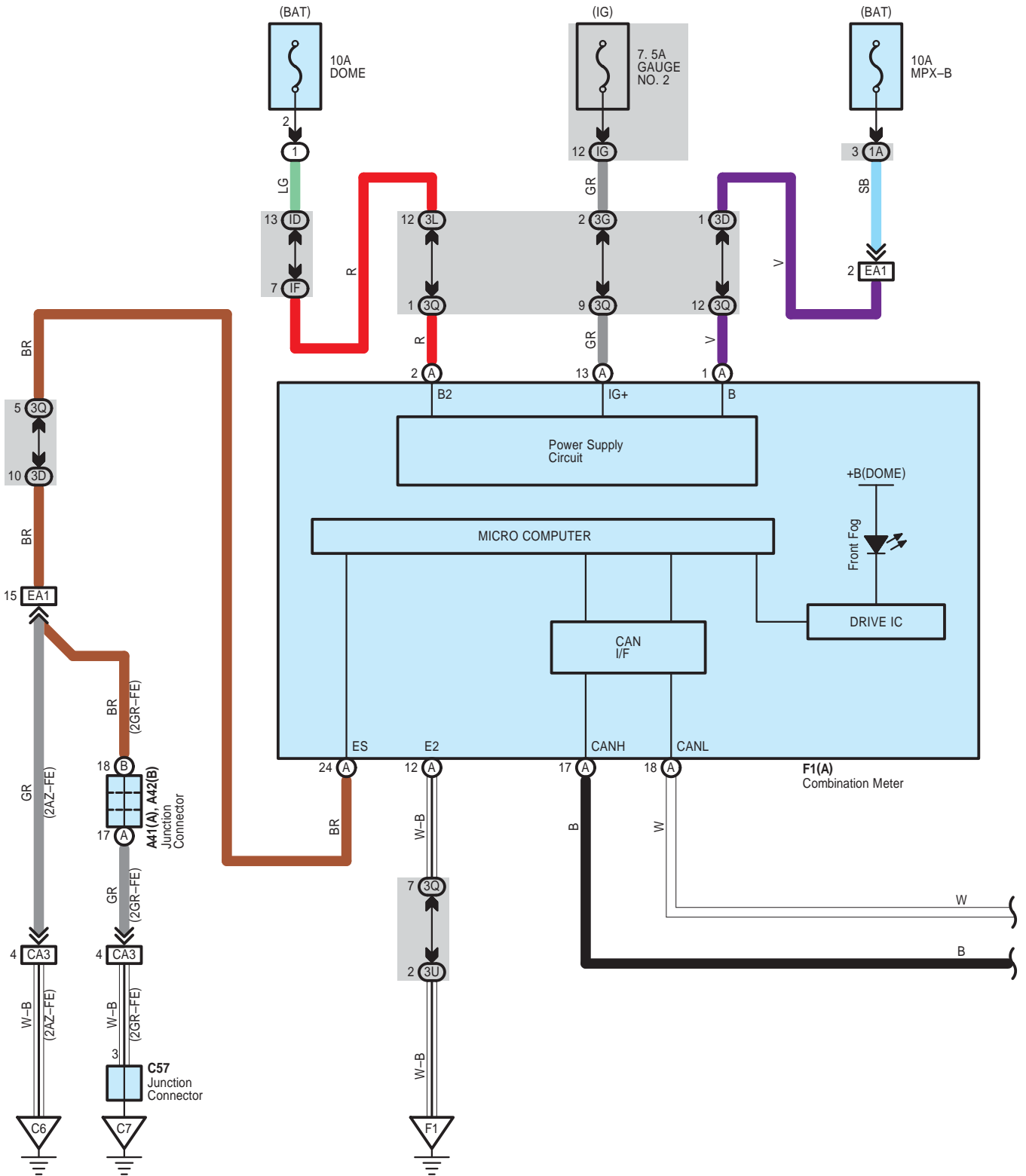

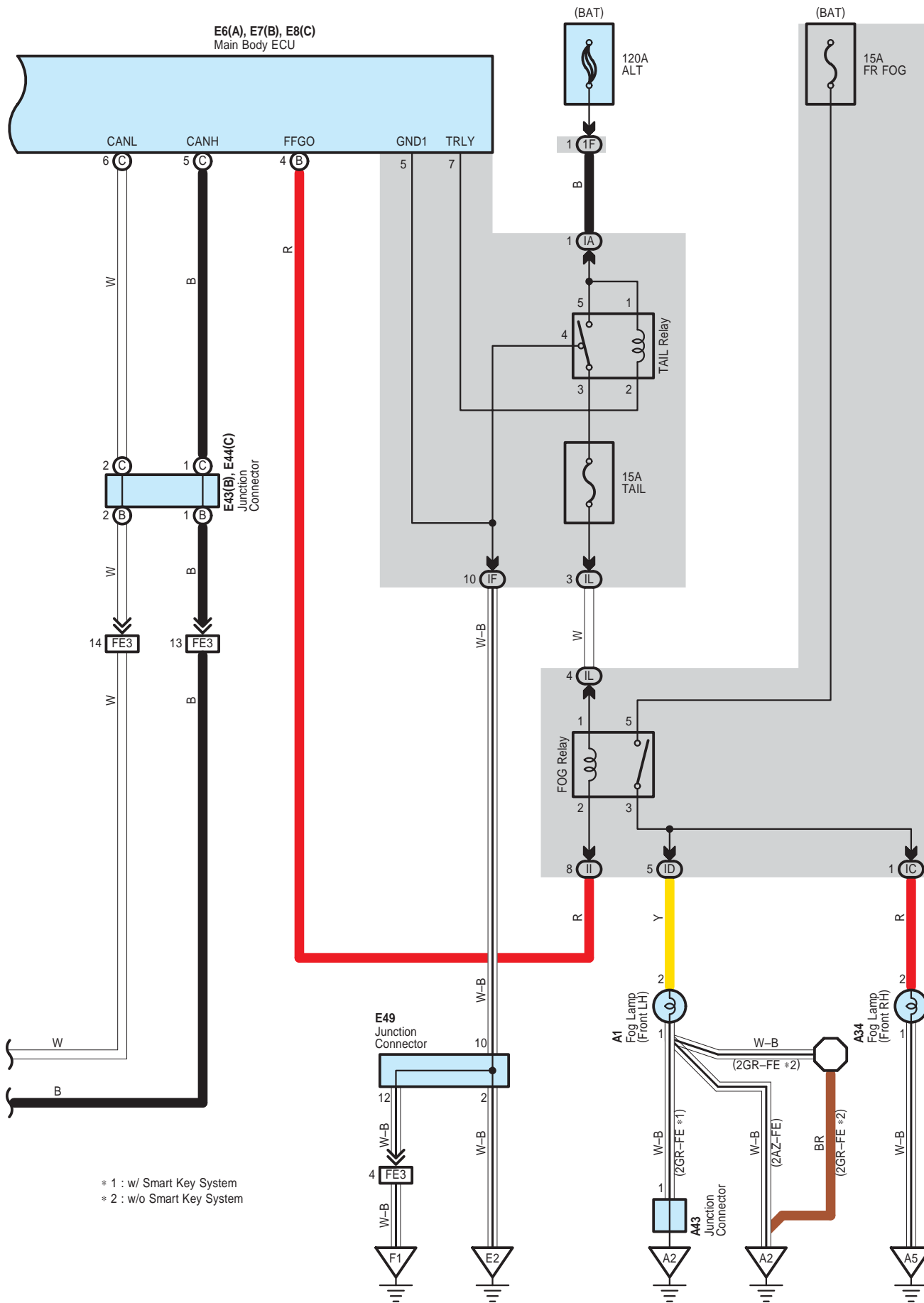

# Fog Light

## ○ : Parts Location

| Code | See Page    | Code | See Page    | Code   | See Page |
|------|-------------|------|-------------|--------|----------|
| A1   | 48 (2GR-FE) | A43  | 49 (2GR-FE) | E43    | B 57     |
|      | 52 (2AZ-FE) | C57  | 51 (2GR-FE) | E44    | C 57     |
| A34  | 48 (2GR-FE) | E6   | A 56        | E49 57 |          |
|      | 52 (2AZ-FE) | E7   | B 56        | F1     | A 58     |
| A41  | A 59        | E8   | C 56        |        |          |
| A42  | B 59        | E21  | 56          |        |          |

## ○ : Relay Blocks

| Code | See Page | Relay Blocks (Relay Block Location)       |
|------|----------|---|
| 1    | 22       | Engine Room R/B (Engine Compartment Left) |

## ○ : Junction Block and Wire Harness Connector

| Code | See Page | Junction Block and Wire Harness (Connector Location)                   |
|------|----------|--|
| 1A   | 25       | Engine Room Main Wire and Engine Room J/B (Engine Compartment Left)    |
| 1F   | 22       |  |
| 3C   | 36       | Instrument Panel Wire and J/B No.3 (Behind the Combination Meter)      |
| 3D   |          |  |
| 3G   |          |  |
| 3L   |          |  |
| 3N   |          |  |
| 3Q   | 36       | Instrument Panel No.2 Wire and J/B No.3 (Behind the Combination Meter) |
| 3U   |          |  |
| 4H   | 42       | Instrument Panel Wire and J/B No.4 (Instrument Panel Brace Center)     |
| 4M   |          |  |
| IA   | 30       | Engine Room Main Wire and Instrument Panel J/B (Cowl Side Left)        |
| IC   |          |  |
| ID   |          |  |
| IF   | 31       | Instrument Panel Wire and Instrument Panel J/B (Cowl Side Left)        |
| IG   |          |  |
| II   |          |  |
| IL   |          |  |
| IM   |          |  |

## □ : Connector Joining Wire Harness and Wire Harness

| Code | See Page    | Joining Wire Harness and Wire Harness (Connector Location)                                |
|------|-------------|---|
| CA3  | 64 (2GR-FE) | Engine Wire and Engine Room Main Wire (Inside of the Engine Room R/B and Engine Room J/B) |
|      | 65 (2AZ-FE) |   |
| EA1  | 66          | Instrument Panel Wire and Engine Room Main Wire (Left Kick Panel)                         |
| FE3  | 66          | Instrument Panel No.2 Wire and Instrument Panel Wire (Instrument Panel Center)            |

## ▽ : Ground Points

| Code | See Page    | Ground Points Location          |
|------|-------------|---------------------------------|
| A2   | 64 (2GR-FE) | Front Left Fender               |
|      | 65 (2AZ-FE) |                                 |
| A5   | 64 (2GR-FE) | Front Right Fender              |
|      | 65 (2AZ-FE) |                                 |
| C6   | 65 (2AZ-FE) | Cylinder Block                  |
| C7   | 64 (2GR-FE) | Left Side of the Cylinder Block |
| E2   | 66          | Instrument Panel Brace LH       |
| F1   | 66          | Instrument Panel Left           |



# Multiplex Communication System – CAN

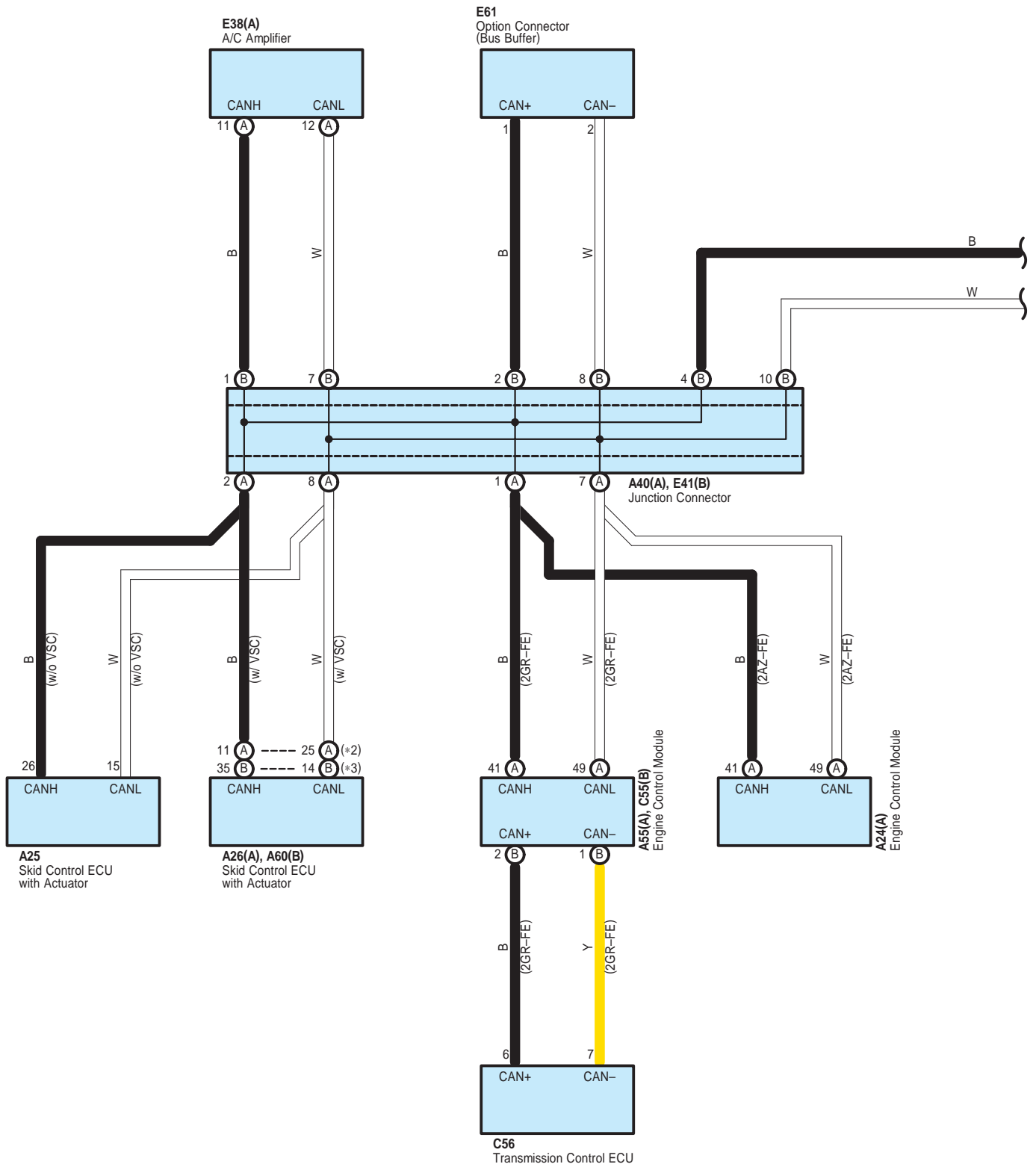

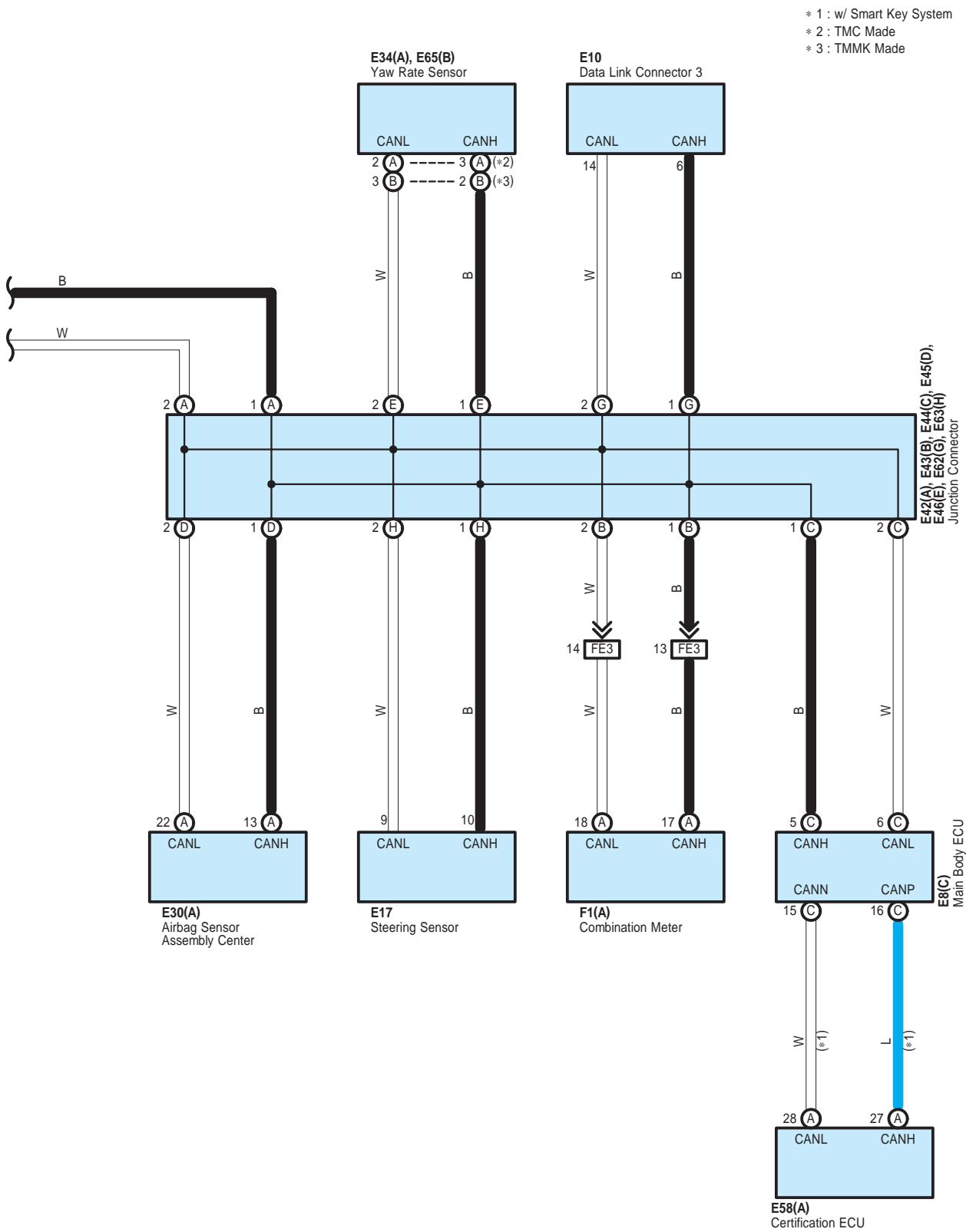

# Multiplex Communication System – CAN

## System Outline

CAN has two lines as a pair which make communication with operating voltage. CAN has excellent data speed and error detecting capacity. It consists of vehicle control systems such as engine control module, yaw rate sensor, skid control ECU with actuator, steering sensor, data link connector 3, A/C amplifier, transmission control ECU, airbag sensor assembly center, combination meter, certification ECU and main body ECU.

## ○ : Parts Location

| Code |   | See Page    | Code |   | See Page    | Code |   | See Page |
|------|---|-------------|------|---|-------------|------|---|----------|
| A24  | A | 52 (2AZ-FE) | C56  |   | 51 (2GR-FE) | E44  | C | 57       |
| A25  |   | 48 (2GR-FE) | E8   | C | 56          | E45  | D | 57       |
|      |   | 52 (2AZ-FE) | E10  |   | 56          | E46  | E | 57       |
| A26  | A | 48 (2GR-FE) | E17  |   | 56          | E58  | A | 57       |
|      |   | 52 (2AZ-FE) | E30  | A | 56          | E61  |   | 57       |
| A40  | A | 59          | E34  | A | 57          | E62  | G | 57       |
| A55  | A | 49 (2GR-FE) | E38  | A | 57          | E63  | H | 57       |
| A60  | B | 49 (2GR-FE) | E41  | B | 57          | E65  | B | 57       |
|      |   | 53 (2AZ-FE) | E42  | A | 57          | F1   | A | 58       |
| C55  | B | 51 (2GR-FE) | E43  | B | 57          |      |   |          |

## □ : Connector Joining Wire Harness and Wire Harness

| Code | See Page | Joining Wire Harness and Wire Harness (Connector Location)                     |
|------|----------|--|
| FE3  | 66       | Instrument Panel No.2 Wire and Instrument Panel Wire (Instrument Panel Center) |





# Automatic Light Control and Light Auto Turn Off System

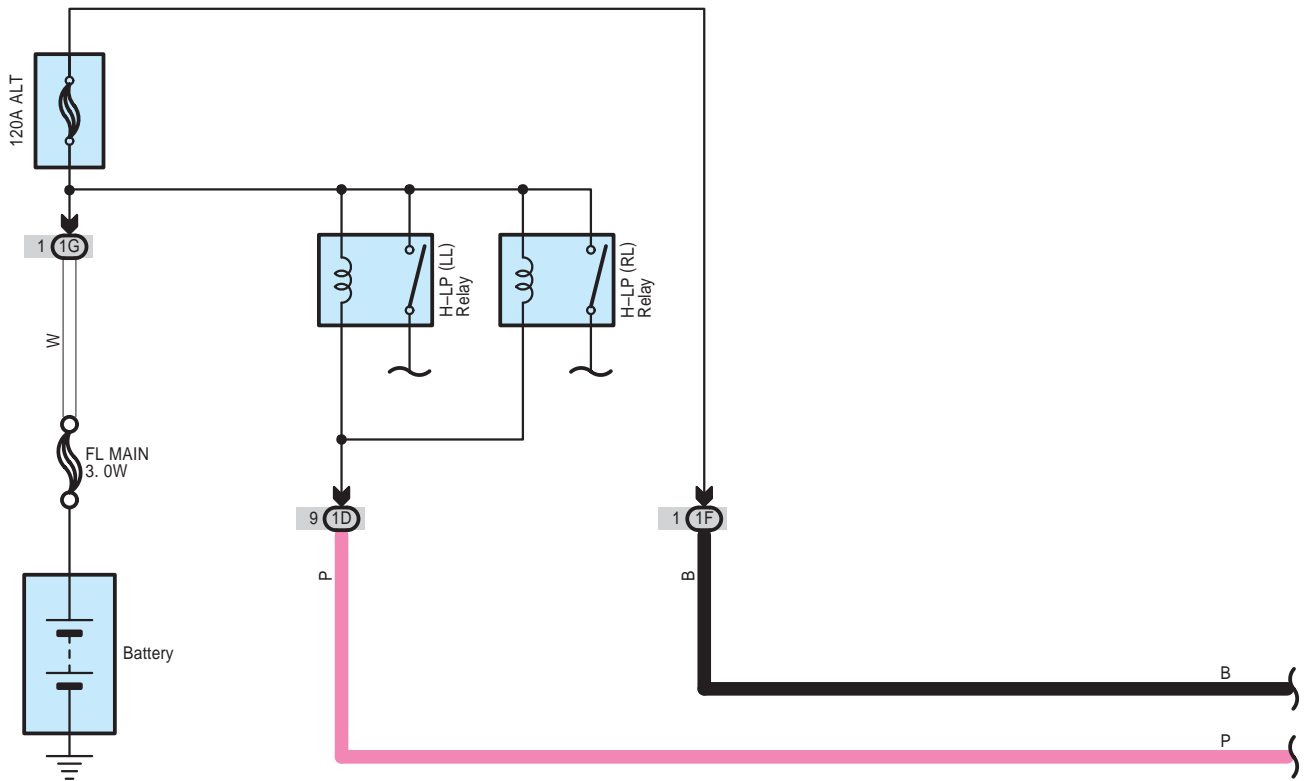
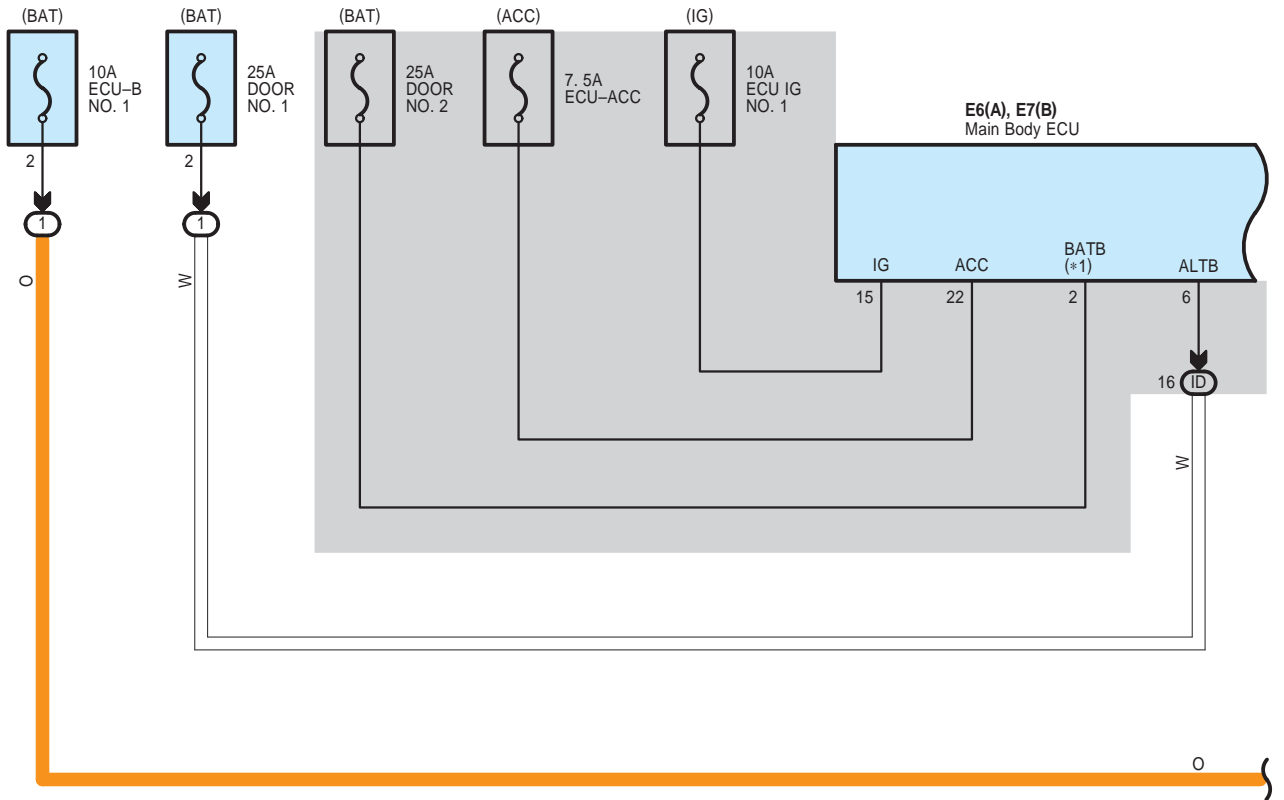

- \* 1 : w/ Smart Key System
- \* 2 : w/o Smart Key System
- \* 3 : TMC Made
- \* 4 : TMMK Made

E6(A), E7(B)  
Main Body ECU

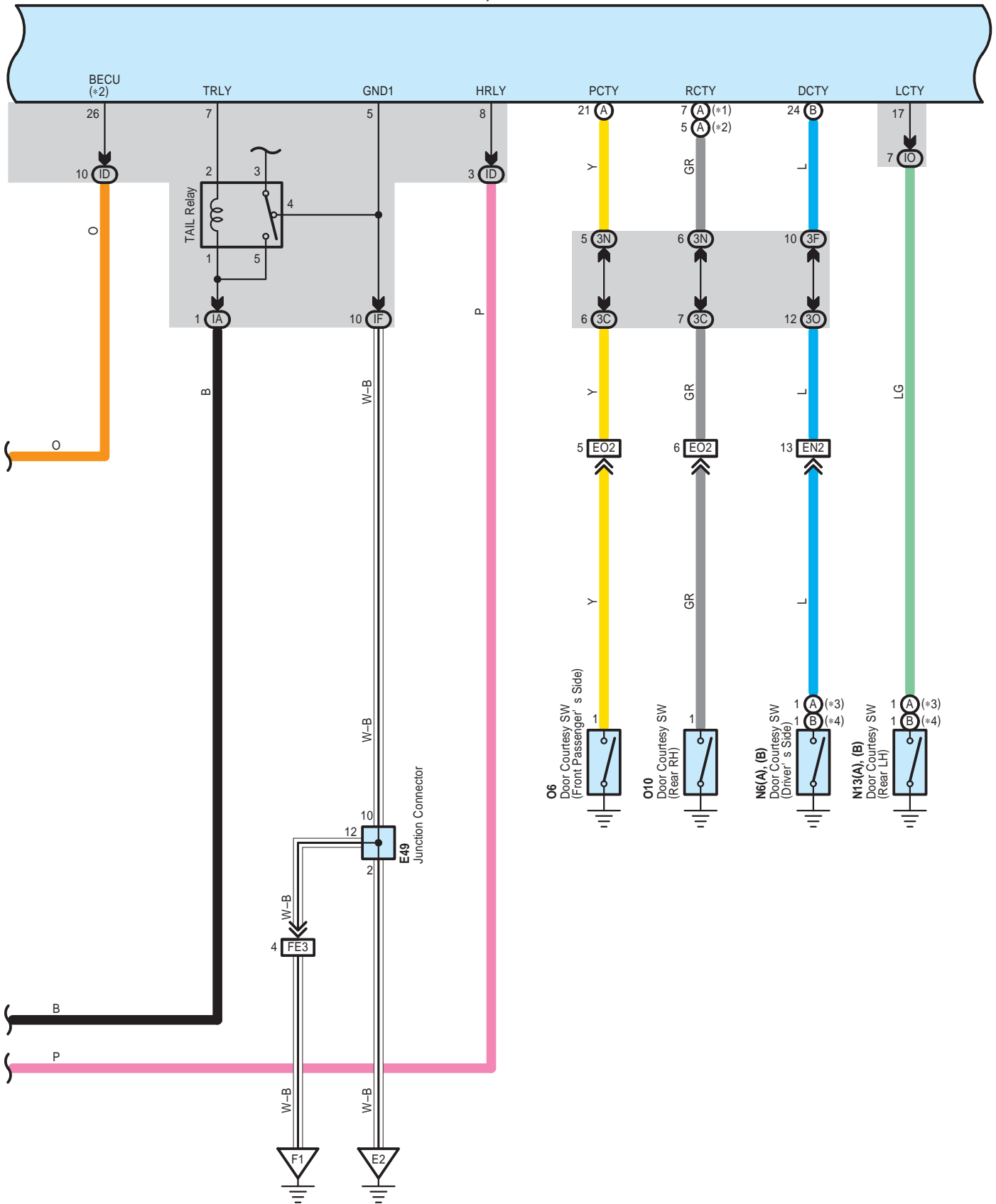

# Automatic Light Control and Light Auto Turn Off System

\* 5 : Automatic A/C  
 \* 6 : Manual A/C

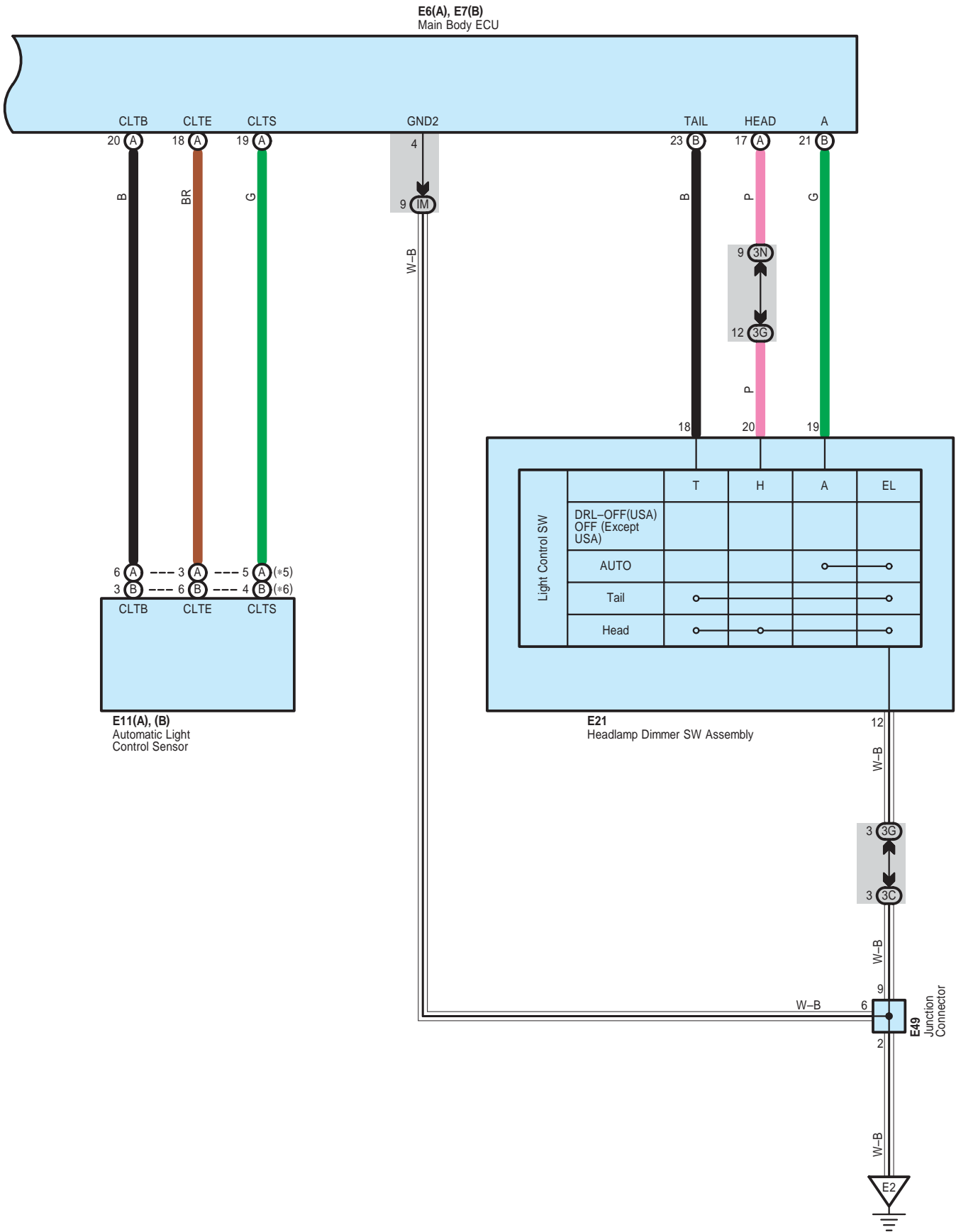

## System Outline

### Automatic Light Control Operation

The automatic light control system works when the light control SW is turned to AUTO. The automatic light control sensor detects the brightness around the vehicle. By this function, the system automatically turns the tail lamp and headlamp on if the brightness is below the regular level and turns the tail lamp and headlamp off when the surroundings become brighter than the regular level.

### Light Auto Turn Off Operation

- \* When the other lamps than headlamps are lit under 'TAIL' or 'AUTO' condition of the light control SW, the tail lamps and front fog lamps are turned OFF if the power SW is changed from 'IG ON' to 'IG OFF' (Power SW type) or the ignition SW is turned from ON to OFF (Ignition SW type), and the driver side door is opened from closed condition.
- \* When the headlamps are lit under 'HEAD' or 'AUTO' condition of the light control SW, if the power SW is changed from 'IG ON' to 'IG OFF' (Power SW type) or the ignition SW is turned from ON to OFF (Ignition SW type), and the light OFF delay time (30 seconds) has passed since all the doors are closed from open condition or under all the door locked condition, operating the wireless door lock function turns OFF the headlamps, tail lamps and front fog lamps.

### : Parts Location

| Code |   | See Page | Code |    | See Page | Code |    | See Page |
|------|---|----------|------|----|----------|------|----|----------|
| E6   | A | 56       | E21  | 56 | N13      | A    | 60 |          |
| E7   | B | 56       | E49  | 57 |          | B    | 60 |          |
| E11  | A | 56       | N6   | A  | 60       | O6   | 60 |          |
|      | B | 56       |      | B  | 60       | O10  | 60 |          |

### : Relay Blocks

| Code | See Page | Relay Blocks (Relay Block Location)       |
|------|----------|---|
| 1    | 22       | Engine Room R/B (Engine Compartment Left) |

### : Junction Block and Wire Harness Connector

| Code | See Page | Junction Block and Wire Harness (Connector Location)                |
|------|----------|---|
| 1D   | 25       | Engine Room Main Wire and Engine Room J/B (Engine Compartment Left) |
| 1F   | 22       |   |
| 1G   |          |   |
| 3C   | 36       | Instrument Panel Wire and J/B No.3 (Behind the Combination Meter)   |
| 3F   |          |   |
| 3G   |          |   |
| 3N   |          |   |
| 3O   |          |   |
| IA   | 30       | Engine Room Main Wire and Instrument Panel J/B (Cowl Side Left)     |
| ID   | 30       | Instrument Panel Wire and Instrument Panel J/B (Cowl Side Left)     |
| IF   |          |   |
| IM   |          |   |
| IO   | 30       | Floor Wire and Instrument Panel J/B (Cowl Side Left)                |

### : Connector Joining Wire Harness and Wire Harness

| Code | See Page | Joining Wire Harness and Wire Harness (Connector Location)                     |
|------|----------|--|
| EN2  | 66       | Instrument Panel Wire and Floor Wire (Left Kick Panel)                         |
| EO2  | 66       | Instrument Panel Wire and Floor No.2 Wire (Right Kick Panel)                   |
| FE3  | 66       | Instrument Panel No.2 Wire and Instrument Panel Wire (Instrument Panel Center) |

### : Ground Points

| Code | See Page | Ground Points Location    |
|------|----------|---------------------------|
| E2   | 66       | Instrument Panel Brace LH |
| F1   | 66       | Instrument Panel Left     |

# Interior Light

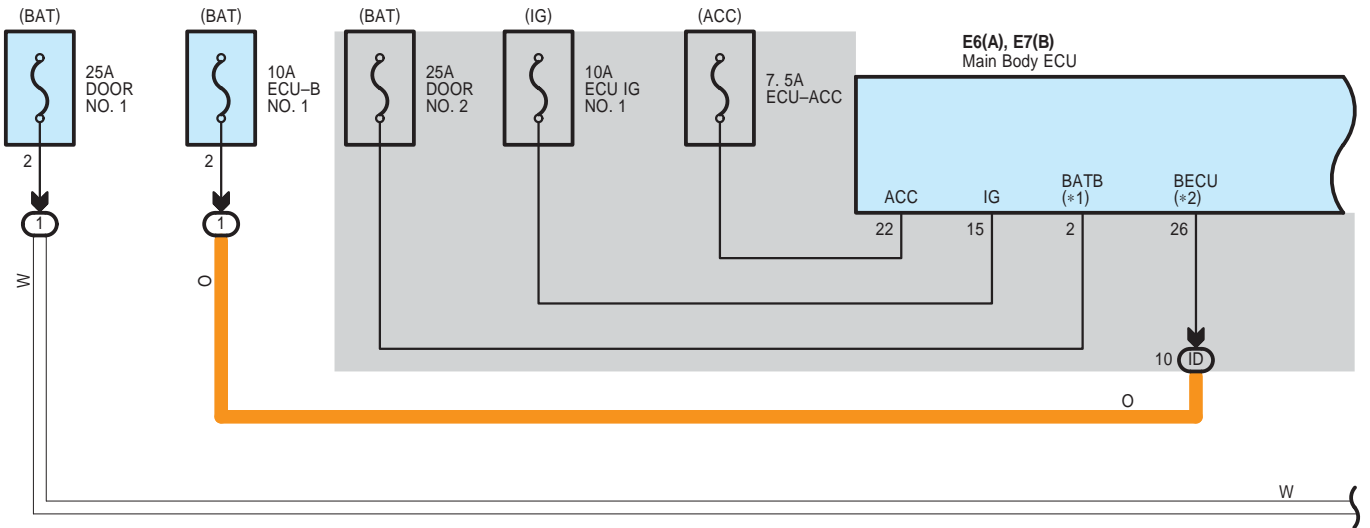

- \* 1 : w/ Smart Key System
- \* 2 : w/o Smart Key System
- \* 3 : TMC Made
- \* 4 : TMMK Made
- \* 5 : w/ Sliding Roof

E6(A), E7(B)  
Main Body ECU

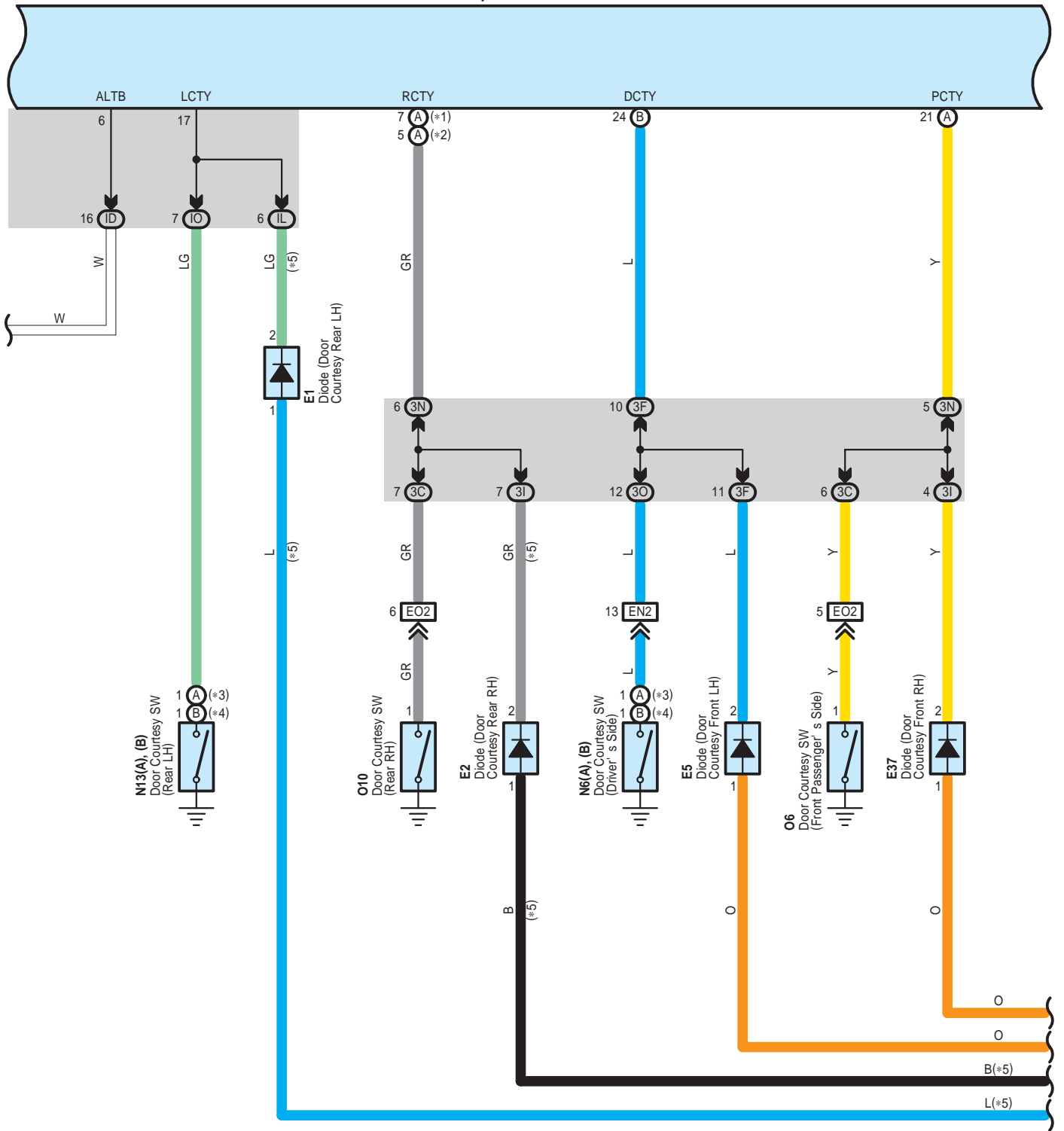

# Interior Light

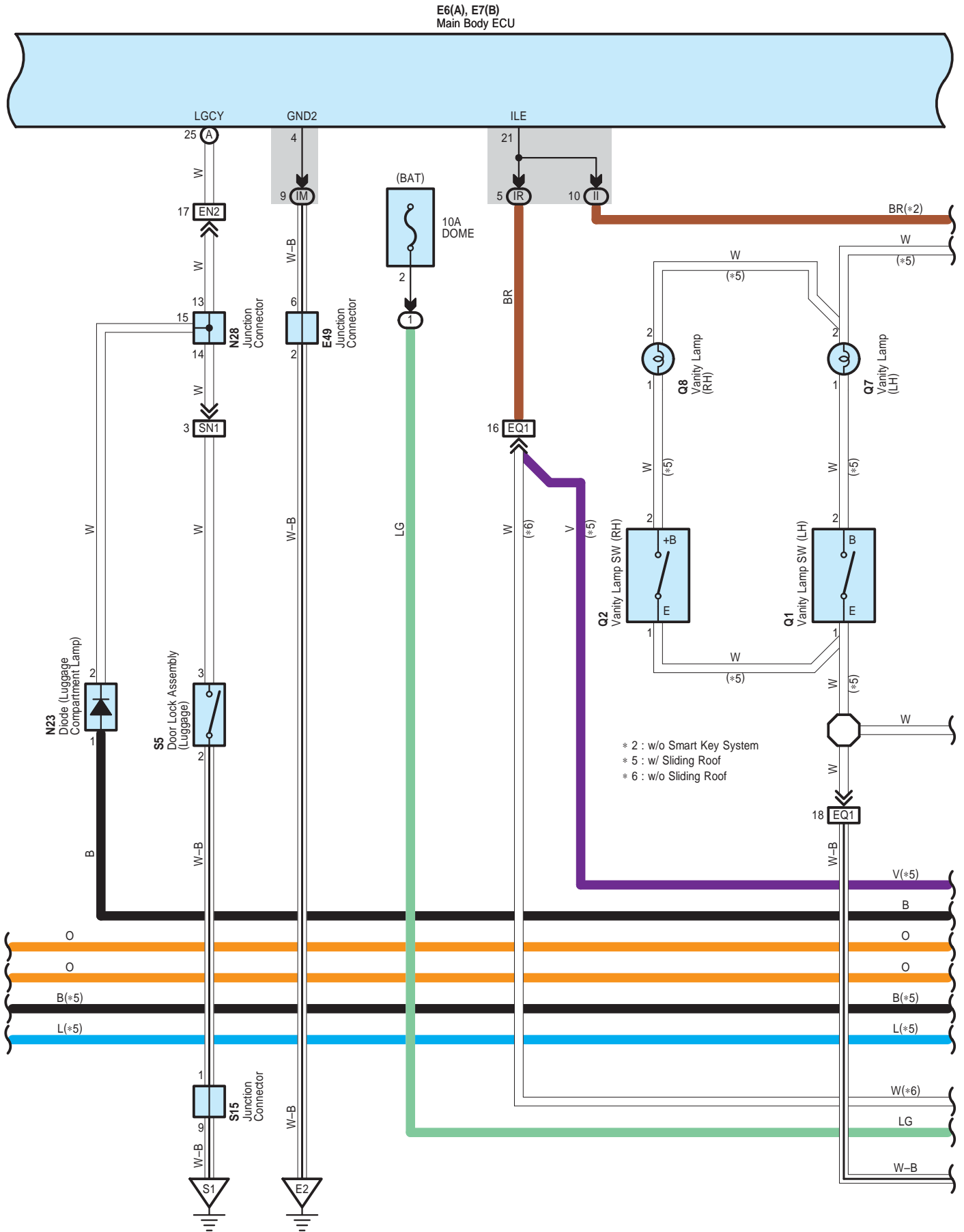

E6(A), E7(B)  
Main Body ECU

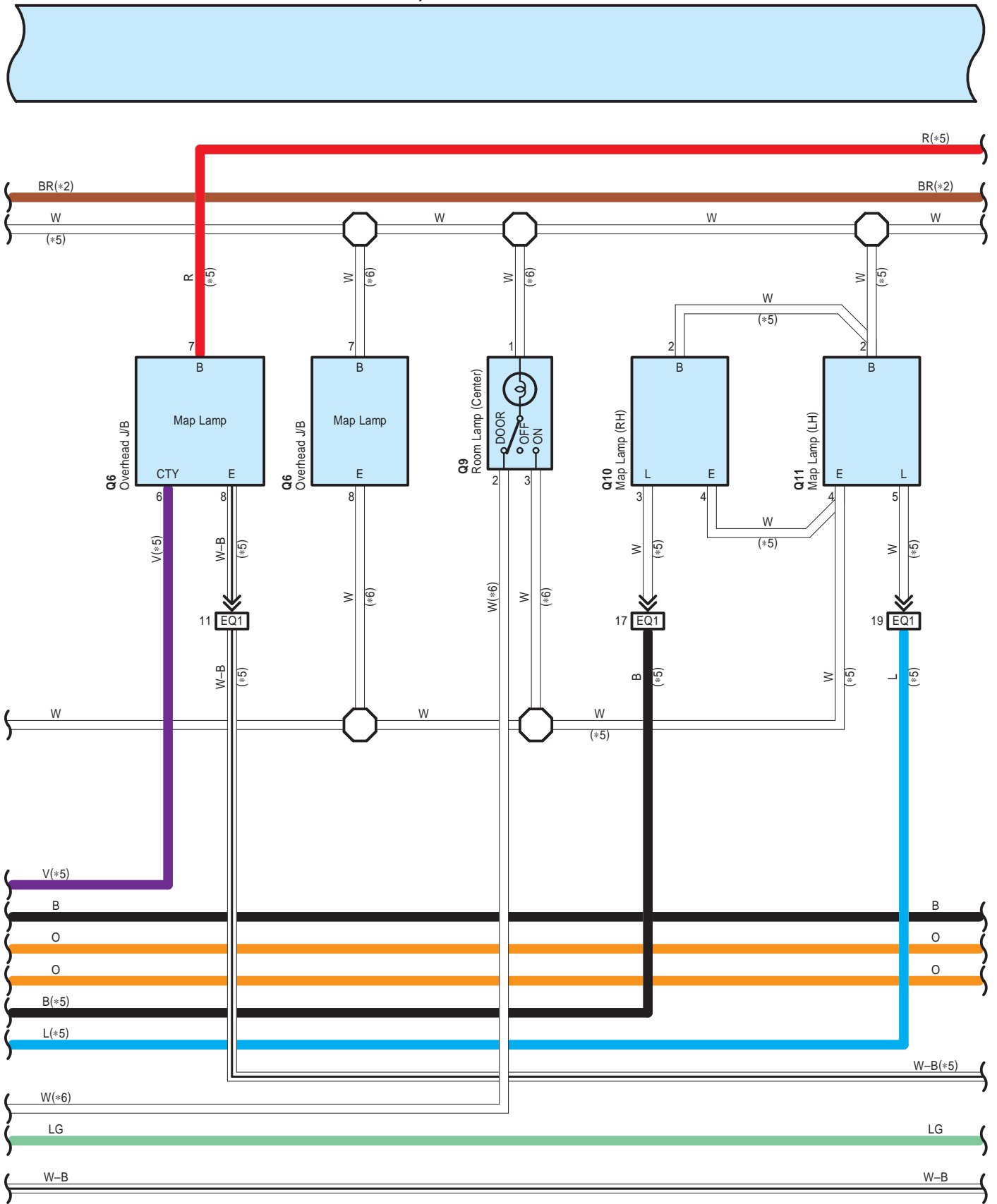



# Interior Light

E6(A), E7(B)  
Main Body ECU

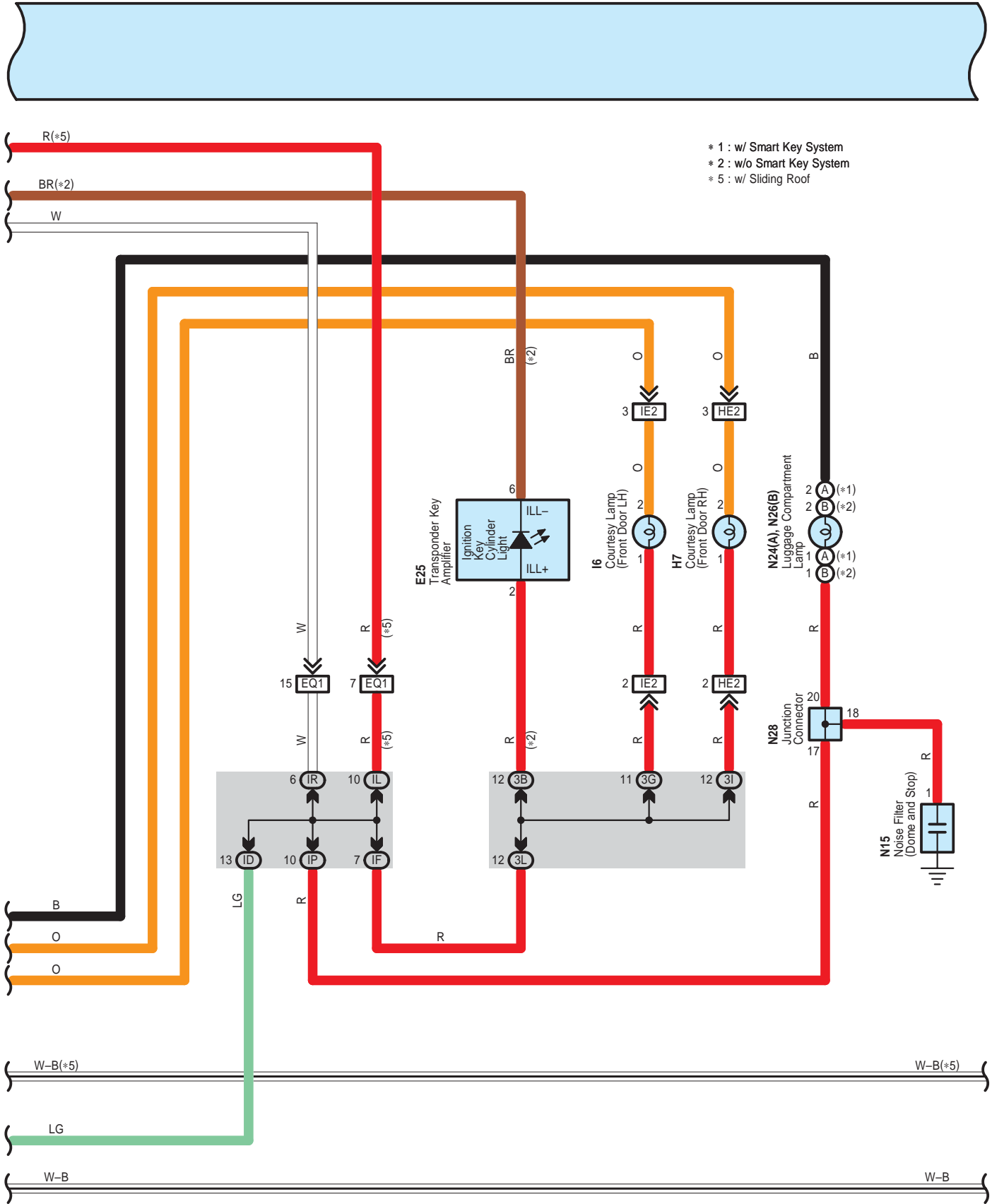

E6(A), E7(B)  
Main Body ECU

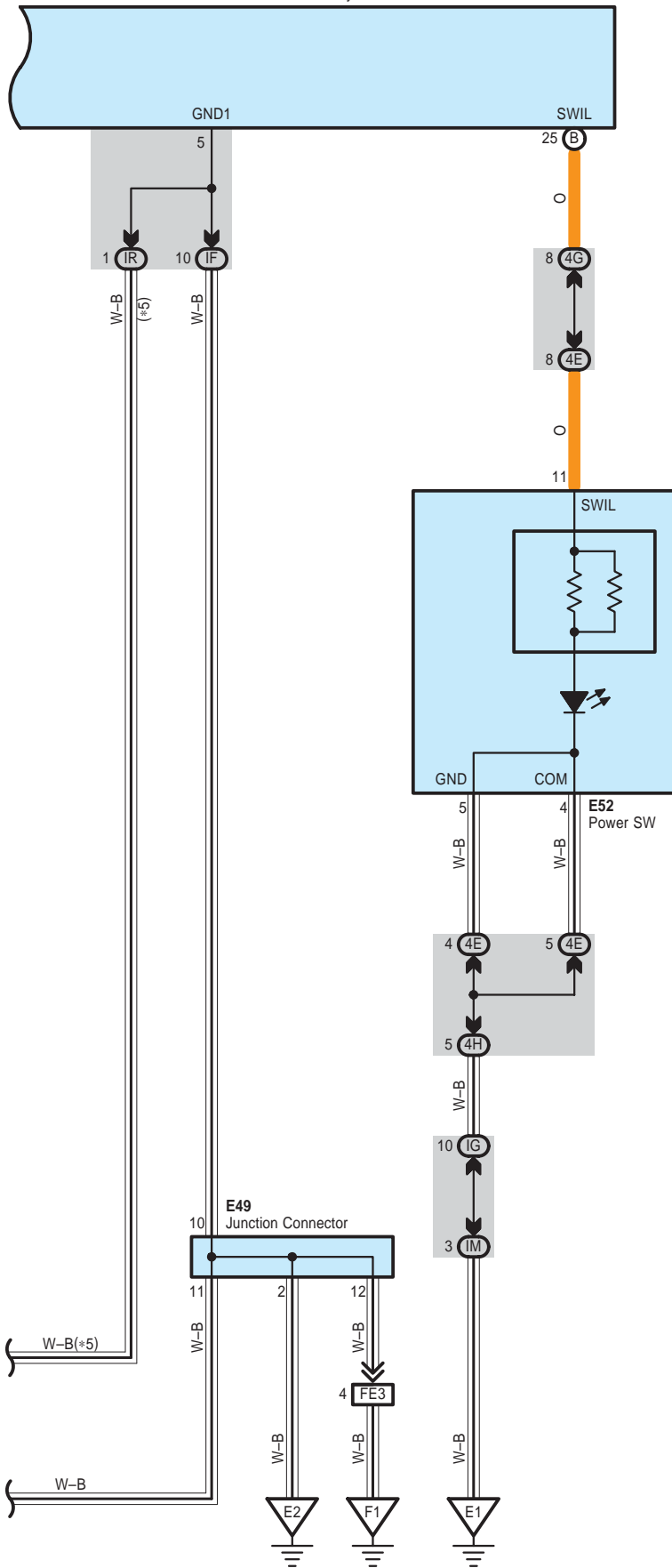

# Interior Light

## System Outline

### 1. Dome Light and Ignition Key Illumination Function

When any door is opened, the dome light (If SW is set to 'DOOR') and ignition key cylinder light are lit in fade-in manner. Then when all the doors are closed (Any door is unlocked), the illumination is kept ON with the timer for approximately for 15 seconds and then is turned OFF in fade-out manner when the timer is completed.

### 2. Battery Saver Function

If the illumination is kept on for 20 minutes with a door open, it is turned OFF automatically.

## ○ : Parts Location

| Code | See Page | Code | See Page | Code | See Page |    |    |
|------|----------|------|----------|------|----------|----|----|
| E1   | 56       | N6   | A        | 60   | Q1       | 61 |    |
| E2   | 56       |      | B        | 60   | Q2       | 61 |    |
| E5   | 56       | N13  | A        | 60   | Q6       | 61 |    |
| E6   | A        |      | 56       | B    | 60       | Q7 | 61 |
| E7   | B        | 56   | N15      |      | 60       | Q8 | 61 |
| E25  | 56       | N23  |          | 60   | Q9       | 61 |    |
| E37  | 57       | N24  | A        | 60   | Q10      | 61 |    |
| E49  | 57       | N26  | B        | 60   | Q11      | 61 |    |
| E52  | 57       | N28  |          | 60   | S5       | 61 |    |
| H7   | 61       | O6   |          | 60   | S15      | 61 |    |
| I6   | 61       | O10  |          | 60   |          |    |    |

## ○ : Relay Blocks

| Code | See Page | Relay Blocks (Relay Block Location)       |
|------|----------|---|
| 1    | 22       | Engine Room R/B (Engine Compartment Left) |

## ○ : Junction Block and Wire Harness Connector

| Code | See Page | Junction Block and Wire Harness (Connector Location)               |
|------|----------|--|
| 3B   | 36       | Instrument Panel Wire and J/B No.3 (Behind the Combination Meter)  |
| 3C   |          |  |
| 3F   |          |  |
| 3G   |          |  |
| 3I   |          |  |
| 3L   |          |  |
| 3N   |          |  |
| 3O   |          |  |
| 4E   | 42       | Instrument Panel Wire and J/B No.4 (Instrument Panel Brace Center) |
| 4G   |          |  |
| 4H   |          |  |
| ID   | 30       | Engine Room Main Wire and Instrument Panel J/B (Cowl Side Left)    |
| IF   | 30       | Instrument Panel Wire and Instrument Panel J/B (Cowl Side Left)    |
| IG   | 31       |  |
| II   |          |  |
| IL   | 30       |  |
| IM   |          |  |
| IO   | 30       | Floor Wire and Instrument Panel J/B (Cowl Side Left)               |
| IP   |          |  |
| IR   | 30       | Instrument Panel Wire and Instrument Panel J/B (Cowl Side Left)    |

 : Connector Joining Wire Harness and Wire Harness

| Code | See Page | Joining Wire Harness and Wire Harness (Connector Location)                     |
|------|----------|--|
| EN2  | 66       | Instrument Panel Wire and Floor Wire (Left Kick Panel)                         |
| EO2  | 66       | Instrument Panel Wire and Floor No.2 Wire (Right Kick Panel)                   |
| EQ1  | 66       | Instrument Panel Wire and Roof Wire (Lower Part of Front Pillar LH)            |
| FE3  | 66       | Instrument Panel No.2 Wire and Instrument Panel Wire (Instrument Panel Center) |
| HE2  | 66       | Front Door RH Wire and Instrument Panel Wire (Right Kick Panel)                |
| IE2  | 66       | Front Door LH Wire and Instrument Panel Wire (Left Kick Panel)                 |
| SN1  | 67       | Luggage Room Wire and Floor Wire (Luggage Room Left)                           |

 : Ground Points

| Code | See Page | Ground Points Location    |
|------|----------|---------------------------|
| E1   | 66       | Instrument Panel Left     |
| E2   | 66       | Instrument Panel Brace LH |
| F1   | 66       | Instrument Panel Left     |
| S1   | 67       | Lower Back Panel Center   |

# Taillight and Illumination

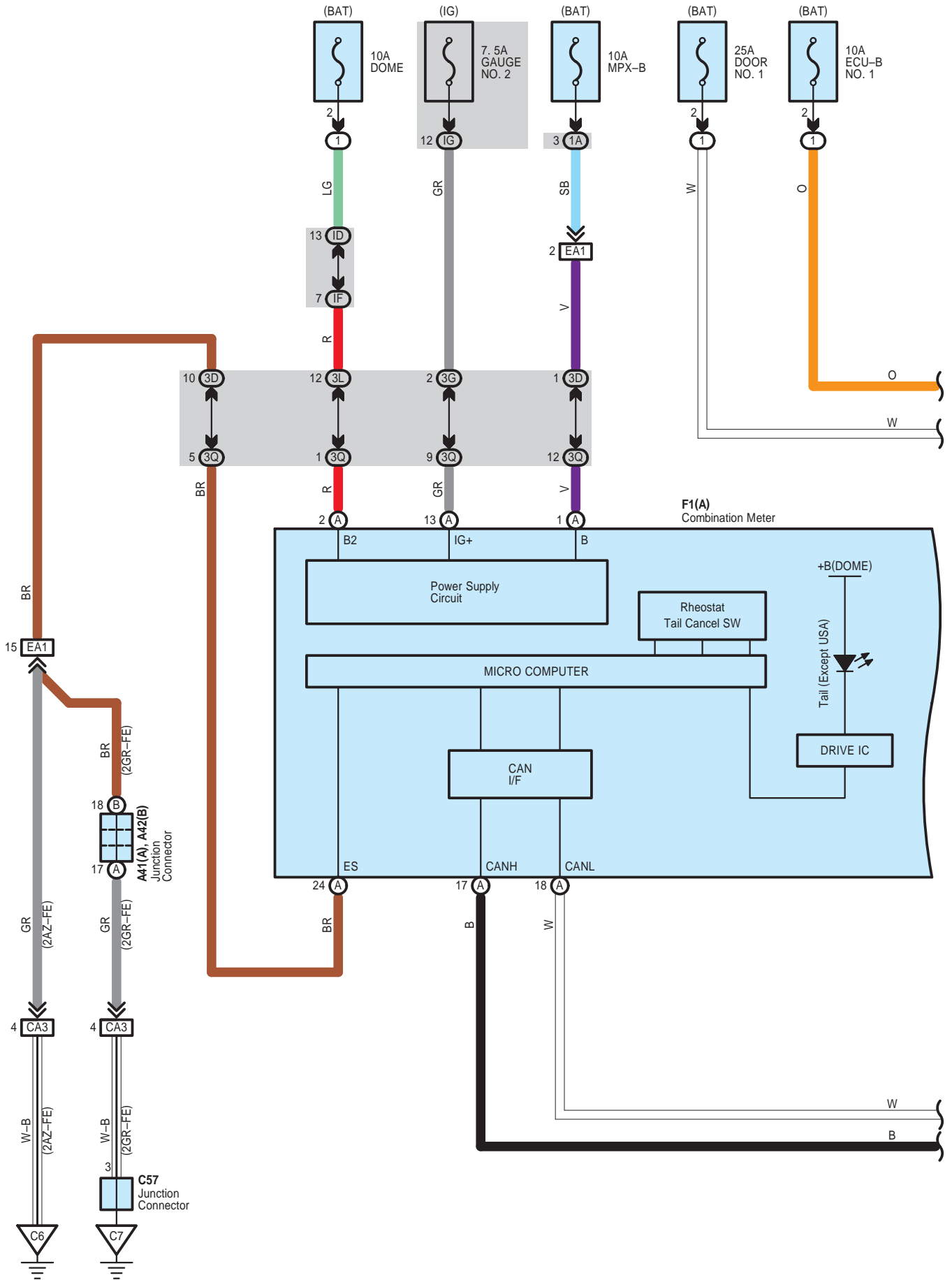

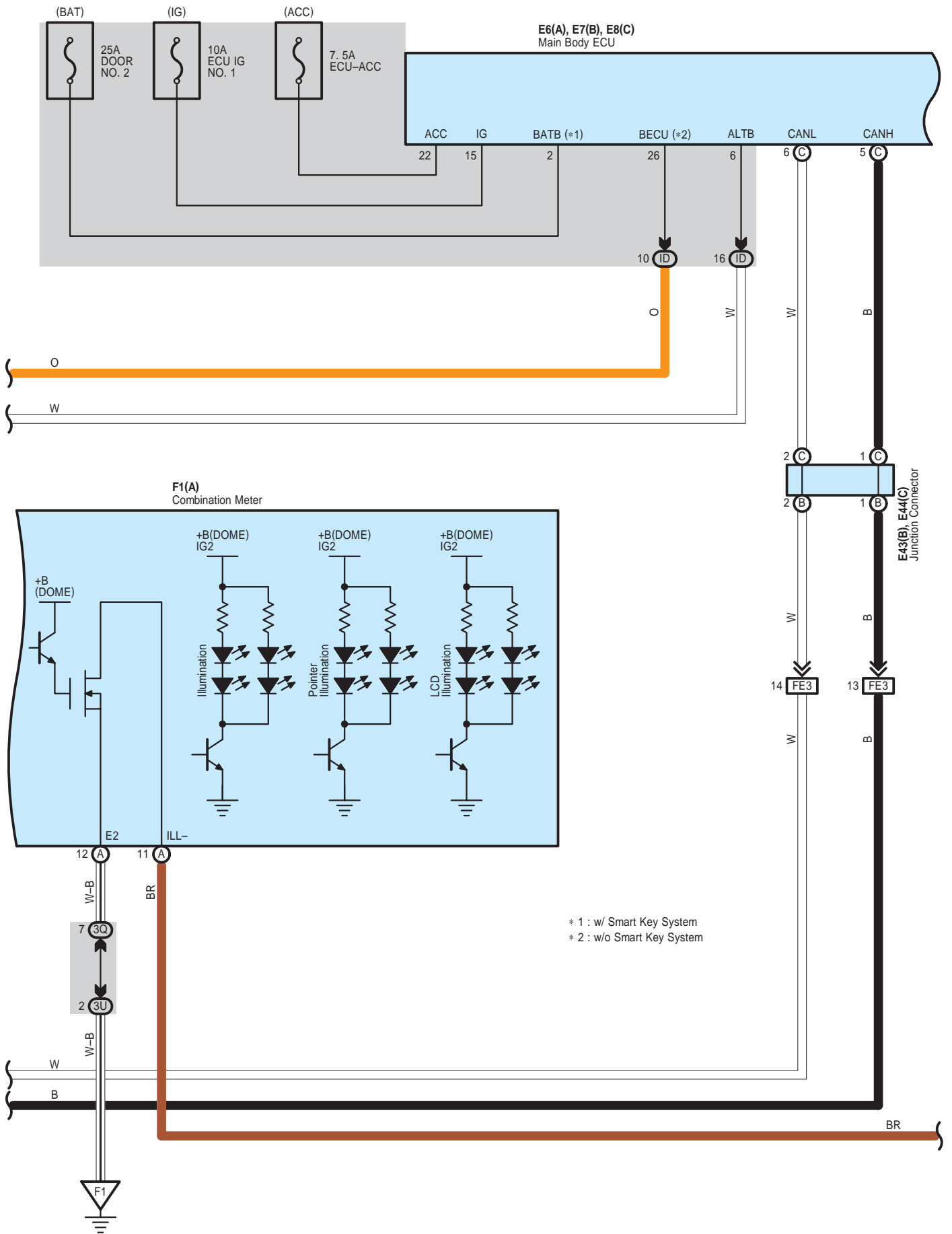

# Taillight and Illumination

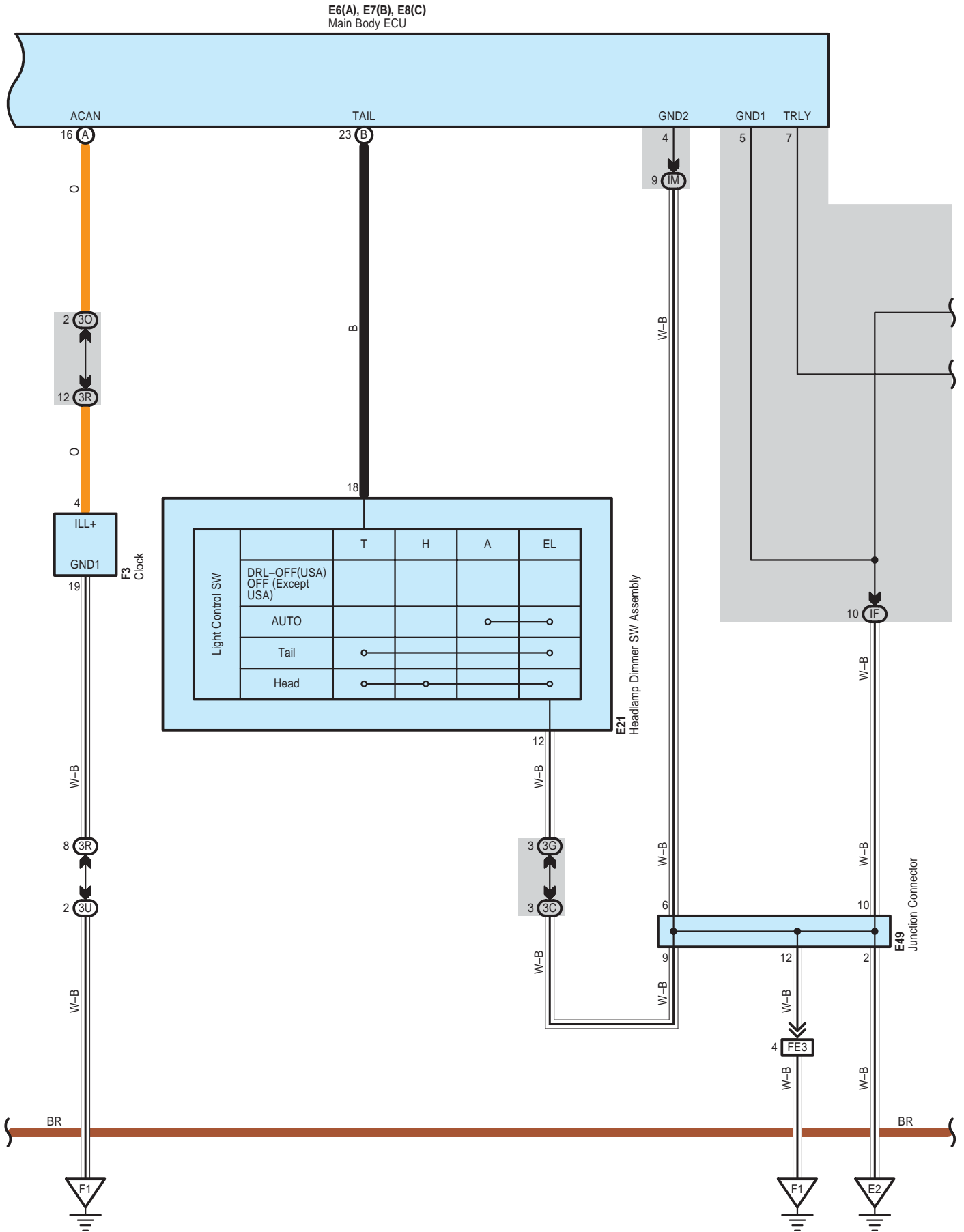

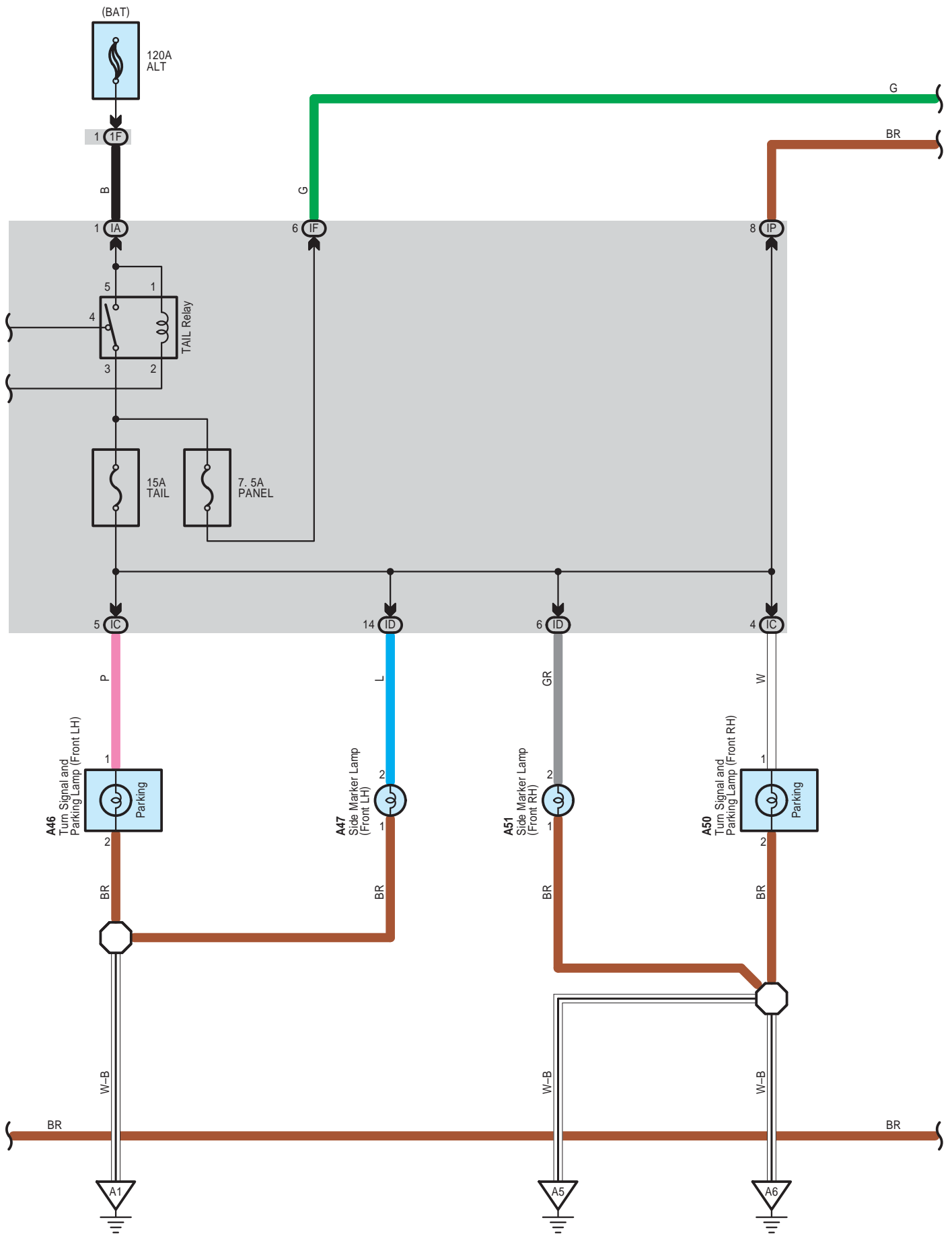



# Taillight and Illumination

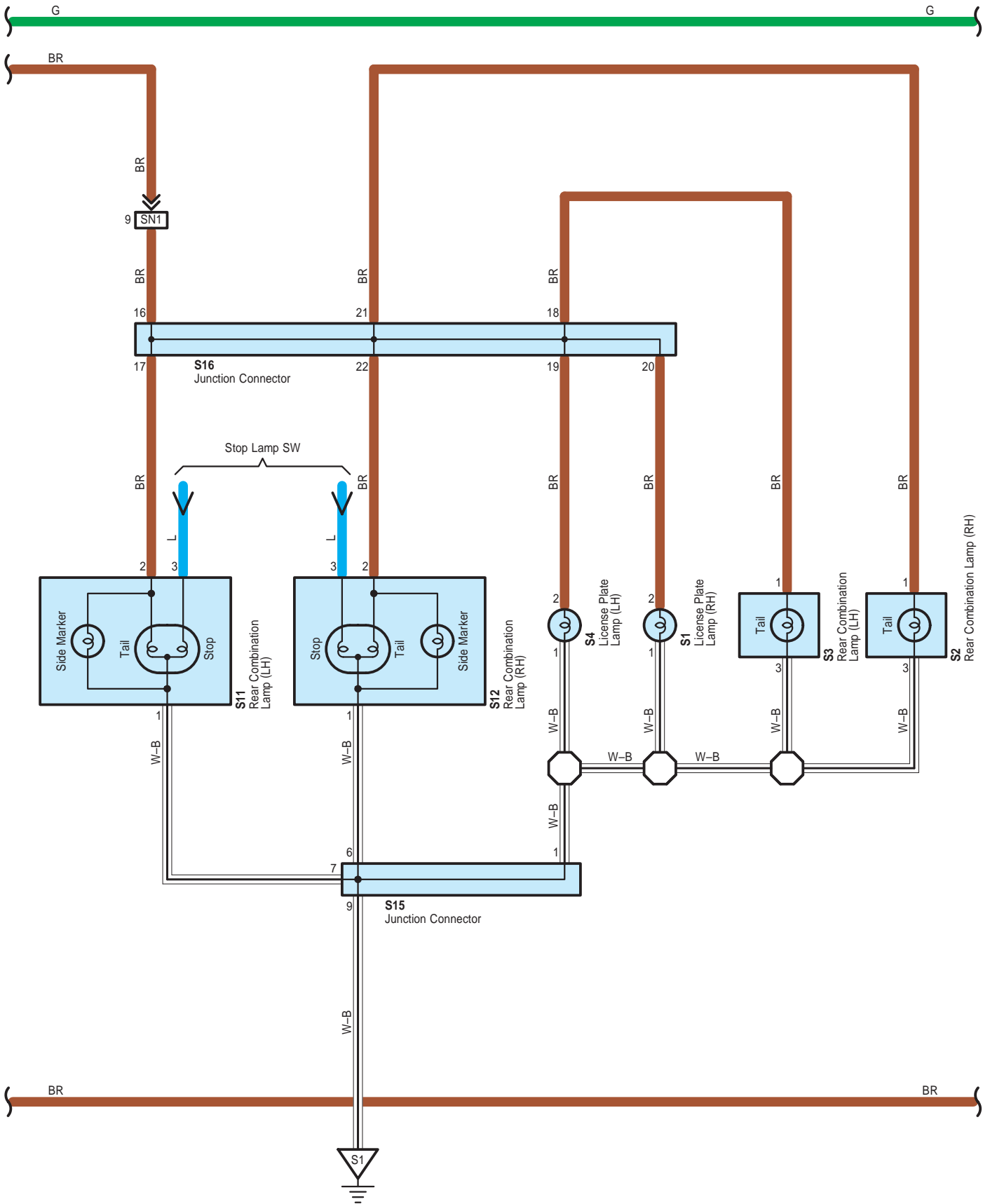

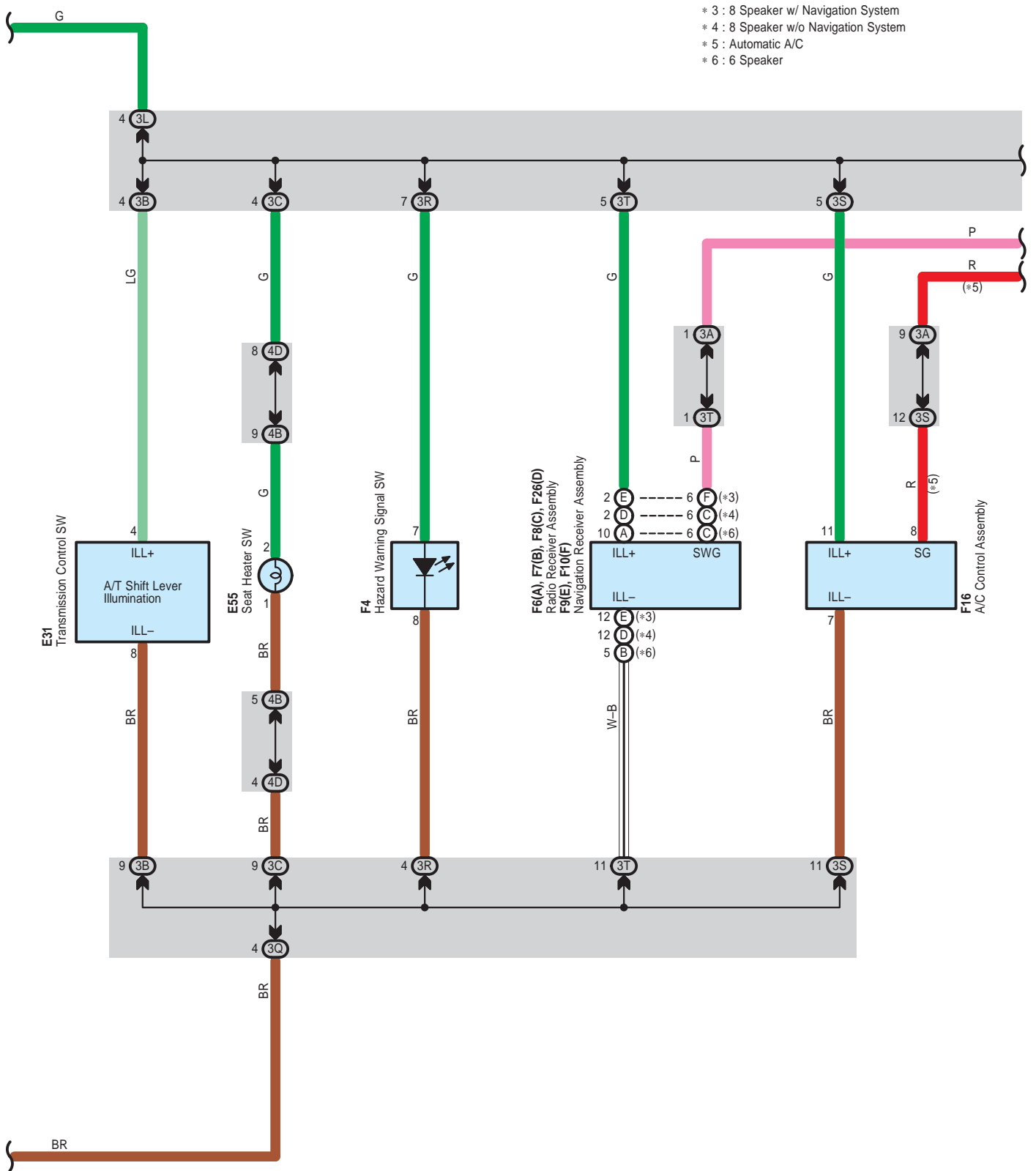

# Taillight and Illumination

\* 5 : Automatic A/C  
 \* 7 : Manual A/C

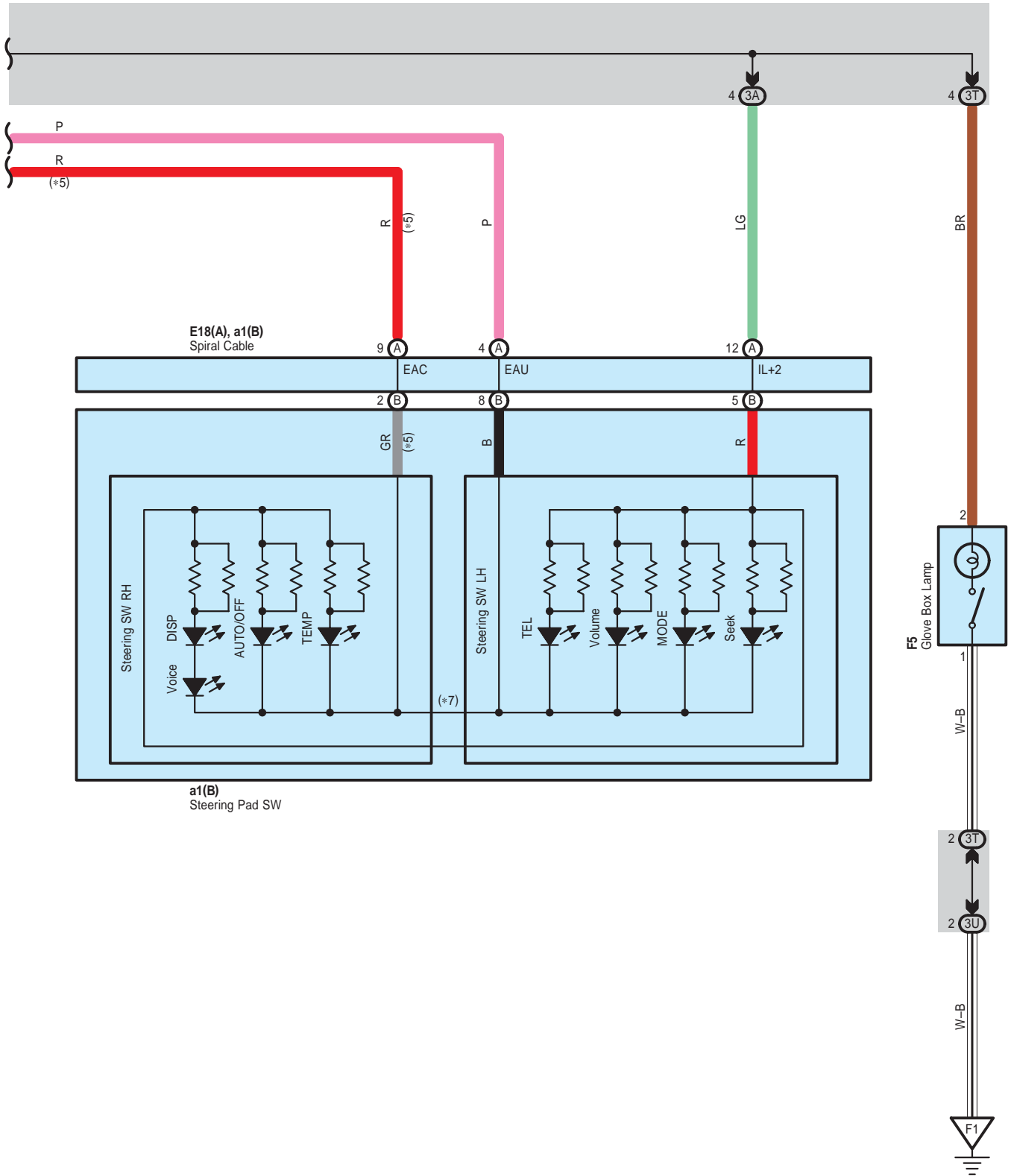

: Parts Location

| Code |             | See Page    | Code |   | See Page | Code |   | See Page |
|------|-------------|-------------|------|---|----------|------|---|----------|
| A41  | A           | 59          | E18  | A | 56       | F9   | E | 58       |
| A42  | B           | 59          | E21  |   | 56       | F10  | F | 58       |
| A46  | 49 (2GR-FE) |             | E31  |   | 56       | F16  |   | 58       |
|      | 53 (2AZ-FE) |             | E43  | B | 57       | F26  | D | 58       |
| A47  | 49 (2GR-FE) |             | E44  | C | 57       | S1   |   | 61       |
|      | 53 (2AZ-FE) |             | E49  |   | 57       | S2   |   | 61       |
| A50  | 49 (2GR-FE) |             | E55  |   | 57       | S3   |   | 61       |
|      | 53 (2AZ-FE) |             | F1   | A | 58       | S4   |   | 61       |
| A51  | 49 (2GR-FE) |             | F3   |   | 58       | S11  |   | 61       |
|      | 53 (2AZ-FE) |             | F4   |   | 58       | S12  |   | 61       |
| C57  |             | 51 (2GR-FE) | F5   |   | 58       | S15  |   | 61       |
| E6   | A           | 56          | F6   | A | 58       | S16  |   | 61       |
| E7   | B           | 56          | F7   | B | 58       | a1   | B | 59       |
| E8   | C           | 56          | F8   | C | 58       |      |   |          |

: Relay Blocks

| Code | See Page | Relay Blocks (Relay Block Location)       |
|------|----------|---|
| 1    | 22       | Engine Room R/B (Engine Compartment Left) |

: Junction Block and Wire Harness Connector

| Code | See Page | Junction Block and Wire Harness (Connector Location)                   |
|------|----------|--|
| 1A   | 25       | Engine Room Main Wire and Engine Room J/B (Engine Compartment Left)    |
| 1F   | 22       |  |
| 3A   | 36       | Instrument Panel Wire and J/B No.3 (Behind the Combination Meter)      |
| 3B   |          |  |
| 3C   |          |  |
| 3D   |          |  |
| 3G   |          |  |
| 3L   |          |  |
| 3O   |          |  |
| 3Q   | 36       | Instrument Panel No.2 Wire and J/B No.3 (Behind the Combination Meter) |
| 3R   |          |  |
| 3S   |          |  |
| 3T   |          |  |
| 3U   |          |  |
| 4B   | 42       | Instrument Panel Wire and J/B No.4 (Instrument Panel Brace Center)     |
| 4D   |          |  |
| IA   | 30       | Engine Room Main Wire and Instrument Panel J/B (Cowl Side Left)        |
| IC   |          |  |
| ID   |          |  |
| IF   | 30       | Instrument Panel Wire and Instrument Panel J/B (Cowl Side Left)        |
| IG   | 31       |  |
| IM   | 30       |  |
| IP   | 30       | Floor Wire and Instrument Panel J/B (Cowl Side Left)                   |

: Connector Joining Wire Harness and Wire Harness

| Code | See Page    | Joining Wire Harness and Wire Harness (Connector Location)                                |
|------|-------------|---|
| CA3  | 64 (2GR-FE) | Engine Wire and Engine Room Main Wire (Inside of the Engine Room R/B and Engine Room J/B) |
|      | 65 (2AZ-FE) |   |
| EA1  | 66          | Instrument Panel Wire and Engine Room Main Wire (Left Kick Panel)                         |
| FE3  | 66          | Instrument Panel No.2 Wire and Instrument Panel Wire (Instrument Panel Center)            |
| SN1  | 67          | Luggage Room Wire and Floor Wire (Luggage Room Left)                                      |

## Taillight and Illumination

---



: Ground Points

| Code | See Page    | Ground Points Location          |
|------|-------------|---------------------------------|
| A1   | 64 (2GR-FE) | Front Left Fender               |
|      | 65 (2AZ-FE) |                                 |
| A5   | 64 (2GR-FE) | Front Right Fender              |
|      | 65 (2AZ-FE) |                                 |
| A6   | 66          | Right Cowl Side Panel           |
| C6   | 65 (2AZ-FE) | Cylinder Block                  |
| C7   | 64 (2GR-FE) | Left Side of the Cylinder Block |
| E2   | 66          | Instrument Panel Brace LH       |
| F1   | 66          | Instrument Panel Left           |
| S1   | 67          | Lower Back Panel Center         |



# Turn Signal and Hazard Warning Light

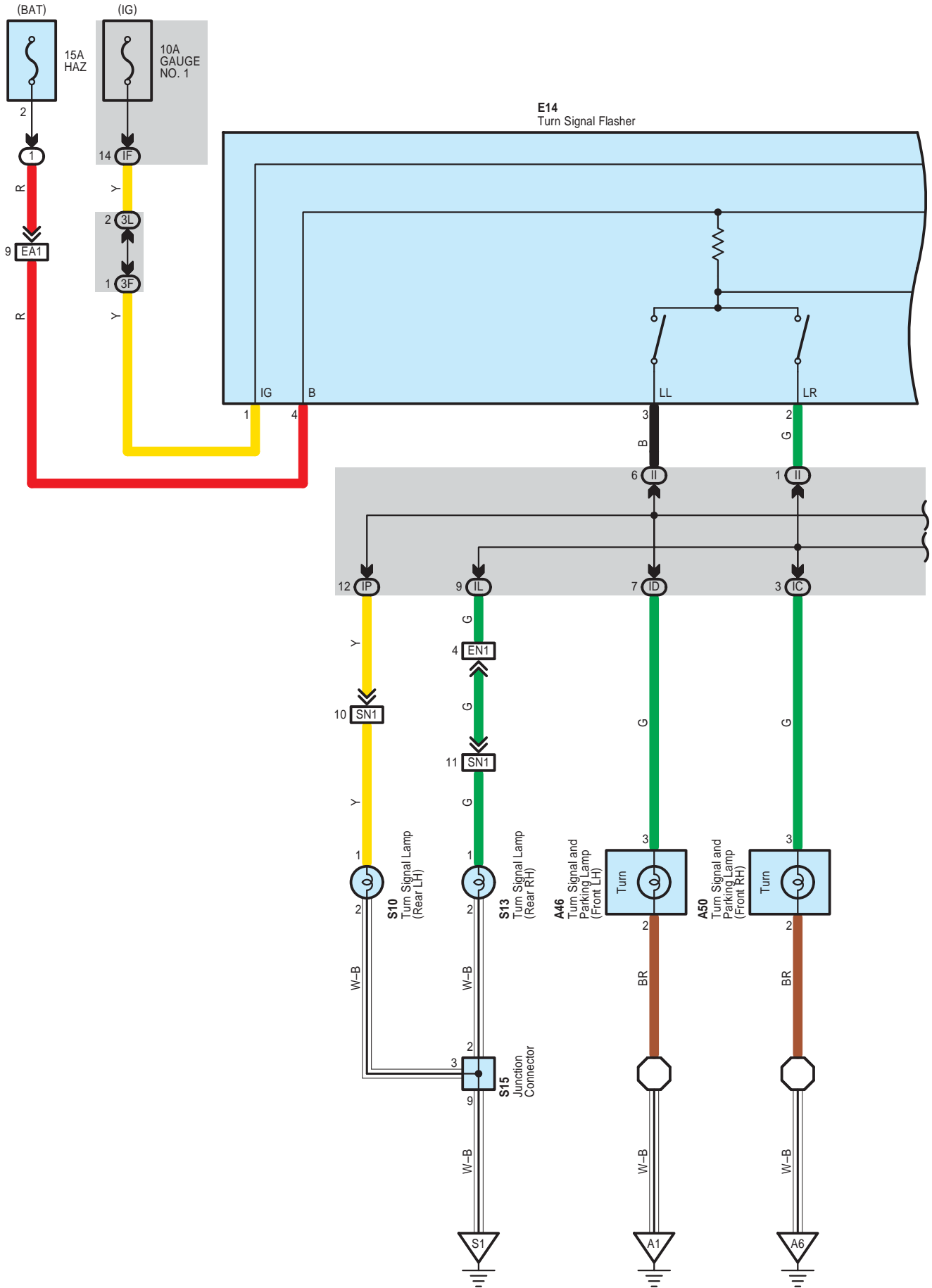

\* 1 : 2GR-FE  
 \* 2 : 2AZ-FE

**E14**  
 Turn Signal Flasher

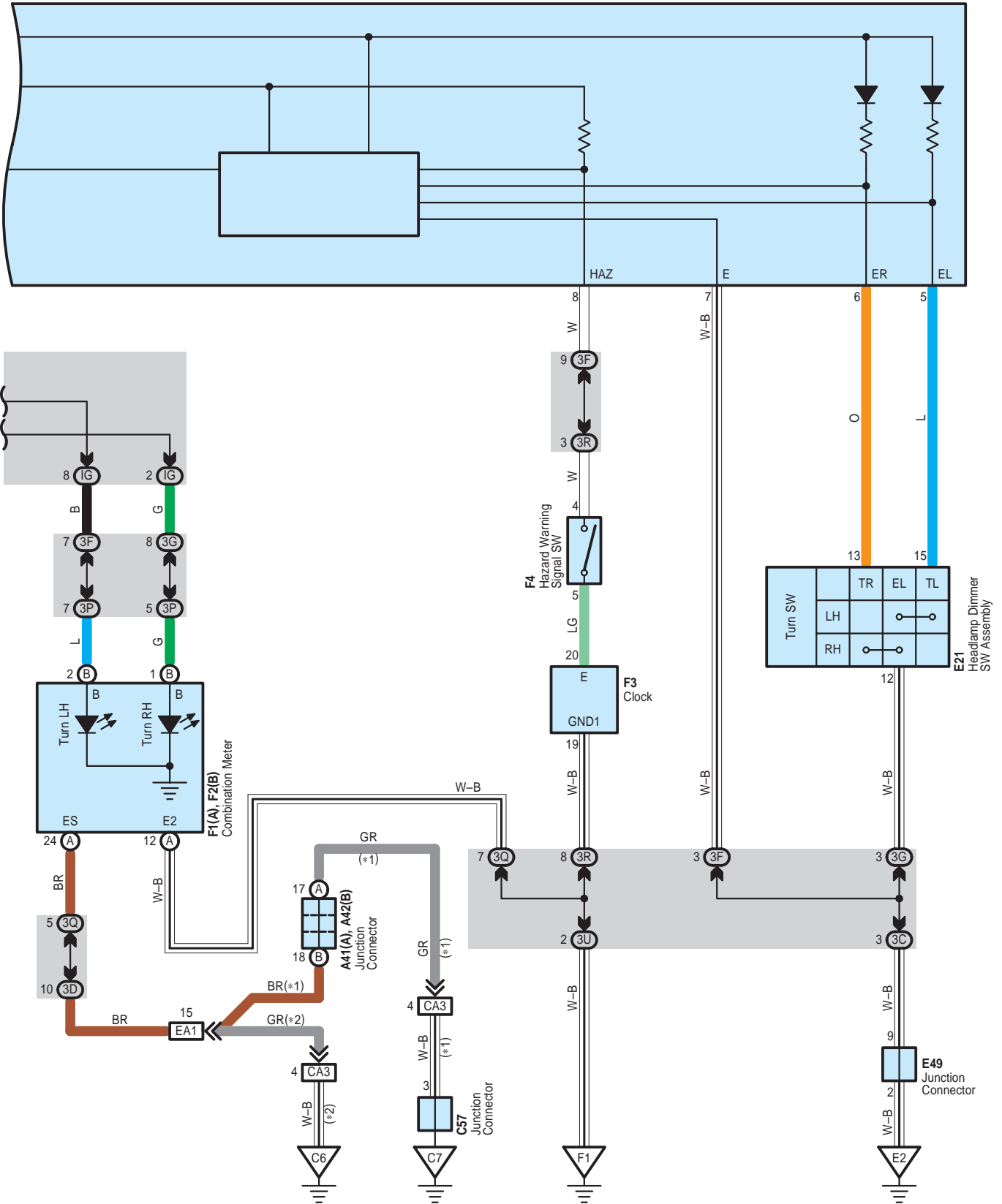



# Turn Signal and Hazard Warning Light

## ○ : Parts Location

| Code |             | See Page | Code |             | See Page | Code |    | See Page |
|------|-------------|----------|------|-------------|----------|------|----|----------|
| A41  | A           | 59       | C57  | 51 (2GR-FE) | F3       | 58   |    |          |
| A42  | B           | 59       | E14  | 56          | F4       | 58   |    |          |
| A46  | 49 (2GR-FE) |          | E21  | 56          | S10      | 61   |    |          |
|      | 53 (2AZ-FE) |          | E49  | 57          | S13      | 61   |    |          |
| A50  | 49 (2GR-FE) |          | F1   | A           | 58       | S15  | 61 |          |
|      | 53 (2AZ-FE) |          | F2   | B           | 58       |      |    |          |

## ○ : Relay Blocks

| Code | See Page | Relay Blocks (Relay Block Location)       |
|------|----------|---|
| 1    | 22       | Engine Room R/B (Engine Compartment Left) |

## ○ : Junction Block and Wire Harness Connector

| Code | See Page | Junction Block and Wire Harness (Connector Location)                   |
|------|----------|--|
| 3C   | 36       | Instrument Panel Wire and J/B No.3 (Behind the Combination Meter)      |
| 3D   |          |  |
| 3F   |          |  |
| 3G   |          |  |
| 3L   |          |  |
| 3P   | 36       | Instrument Panel No.2 Wire and J/B No.3 (Behind the Combination Meter) |
| 3Q   |          |  |
| 3R   |          |  |
| 3U   |          |  |
| IC   | 30       | Engine Room Main Wire and Instrument Panel J/B (Cowl Side Left)        |
| ID   |          |  |
| IF   | 30       | Instrument Panel Wire and Instrument Panel J/B (Cowl Side Left)        |
| IG   | 31       |  |
| II   |          |  |
| IL   | 30       |  |
| IP   | 30       | Floor Wire and Instrument Panel J/B (Cowl Side Left)                   |

## □ : Connector Joining Wire Harness and Wire Harness

| Code | See Page    | Joining Wire Harness and Wire Harness (Connector Location)                                |
|------|-------------|---|
| CA3  | 64 (2GR-FE) | Engine Wire and Engine Room Main Wire (Inside of the Engine Room R/B and Engine Room J/B) |
|      | 65 (2AZ-FE) |   |
| EA1  | 66          | Instrument Panel Wire and Engine Room Main Wire (Left Kick Panel)                         |
| EN1  | 66          | Instrument Panel Wire and Floor Wire (Left Kick Panel)                                    |
| SN1  | 67          | Luggage Room Wire and Floor Wire (Luggage Room Left)                                      |

## ▽ : Ground Points

| Code | See Page    | Ground Points Location          |
|------|-------------|---------------------------------|
| A1   | 64 (2GR-FE) | Front Left Fender               |
|      | 65 (2AZ-FE) |                                 |
| A6   | 66          | Right Cowl Side Panel           |
| C6   | 65 (2AZ-FE) | Cylinder Block                  |
| C7   | 64 (2GR-FE) | Left Side of the Cylinder Block |
| E2   | 66          | Instrument Panel Brace LH       |
| F1   | 66          | Instrument Panel Left           |
| S1   | 67          | Lower Back Panel Center         |



# Stop Light

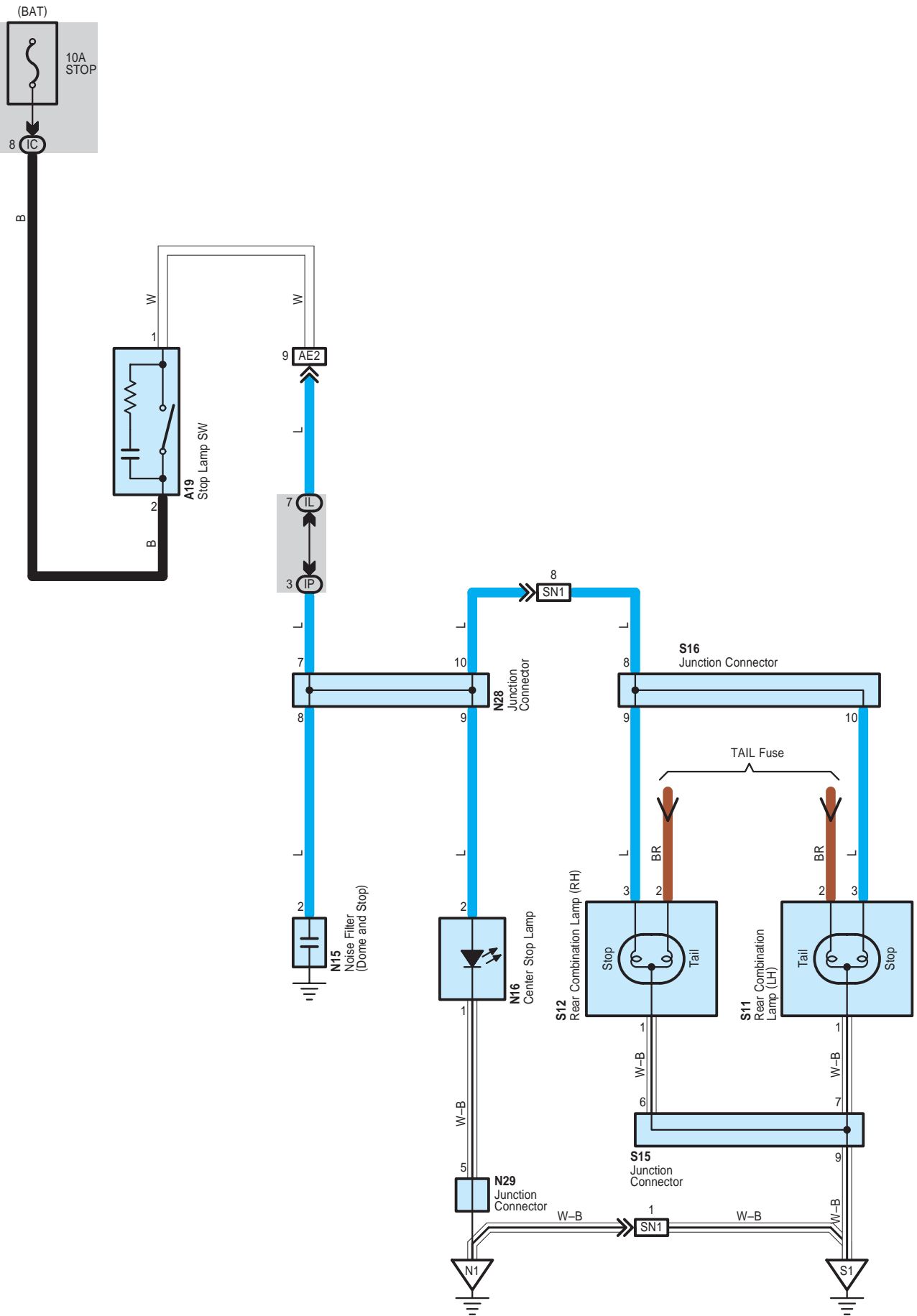

 : **Parts Location**

| Code | See Page | Code | See Page | Code | See Page |
|------|----------|------|----------|------|----------|
| A19  | 59       | N28  | 60       | S12  | 61       |
| N15  | 60       | N29  | 60       | S15  | 61       |
| N16  | 60       | S11  | 61       | S16  | 61       |

 : **Junction Block and Wire Harness Connector**

| Code | See Page | Junction Block and Wire Harness (Connector Location)            |
|------|----------|---|
| IC   | 30       | Engine Room Main Wire and Instrument Panel J/B (Cowl Side Left) |
| IL   | 30       | Instrument Panel Wire and Instrument Panel J/B (Cowl Side Left) |
| IP   | 30       | Floor Wire and Instrument Panel J/B (Cowl Side Left)            |

 : **Connector Joining Wire Harness and Wire Harness**

| Code | See Page | Joining Wire Harness and Wire Harness (Connector Location)                               |
|------|----------|--|
| AE2  | 66       | Engine Room Main Wire and Instrument Panel Wire (Right Side of the Instrument Panel J/B) |
| SN1  | 67       | Luggage Room Wire and Floor Wire (Luggage Room Left)                                     |

 : **Ground Points**

| Code | See Page | Ground Points Location  |
|------|----------|-------------------------|
| N1   | 67       | Left Rear Quarter Panel |
| S1   | 67       | Lower Back Panel Center |

# Back-Up Light

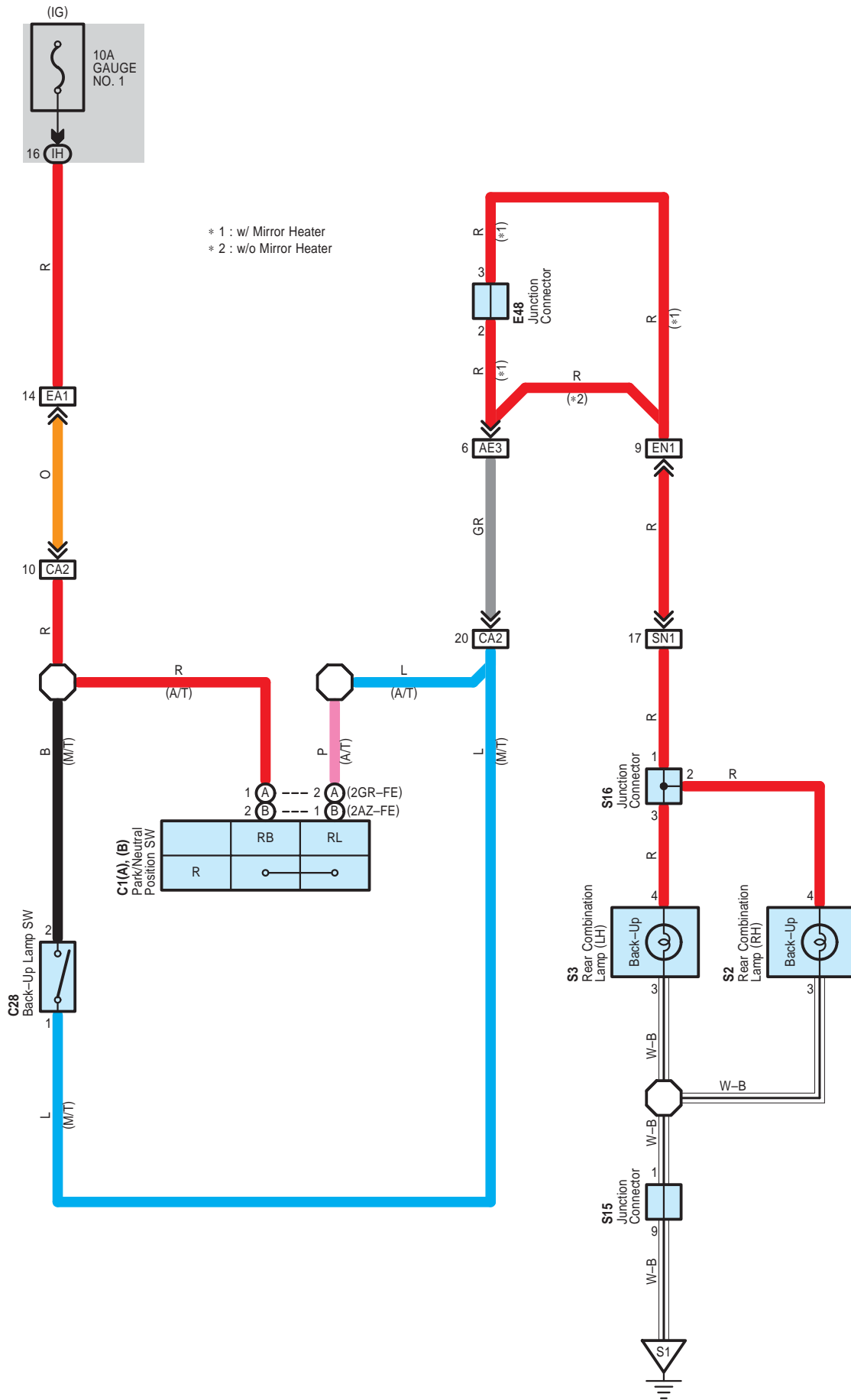

 : **Parts Location**

| Code | See Page    | Code        | See Page | Code | See Page |    |
|------|-------------|-------------|----------|------|----------|----|
| C1   | A           | 50 (2GR-FE) | E48      | 57   | S15      | 61 |
|      | B           | 54 (2AZ-FE) | S2       | 61   | S16      | 61 |
| C28  | 55 (2AZ-FE) | S3          | 61       |      |          |    |

 : **Junction Block and Wire Harness Connector**

| Code | See Page | Junction Block and Wire Harness (Connector Location)            |
|------|----------|---|
| IH   | 31       | Instrument Panel Wire and Instrument Panel J/B (Cowl Side Left) |

 : **Connector Joining Wire Harness and Wire Harness**

| Code | See Page    | Joining Wire Harness and Wire Harness (Connector Location)                                |
|------|-------------|---|
| AE3  | 66          | Engine Room Main Wire and Instrument Panel Wire (Instrument Panel Right)                  |
| CA2  | 64 (2GR-FE) | Engine Wire and Engine Room Main Wire (Inside of the Engine Room R/B and Engine Room J/B) |
|      | 65 (2AZ-FE) |   |
| EA1  | 66          | Instrument Panel Wire and Engine Room Main Wire (Left Kick Panel)                         |
| EN1  | 66          | Instrument Panel Wire and Floor Wire (Left Kick Panel)                                    |
| SN1  | 67          | Luggage Room Wire and Floor Wire (Luggage Room Left)                                      |

 : **Ground Points**

| Code | See Page | Ground Points Location  |
|------|----------|-------------------------|
| S1   | 67       | Lower Back Panel Center |

# Key Reminder without Smart Key System and Seat Belt Warning

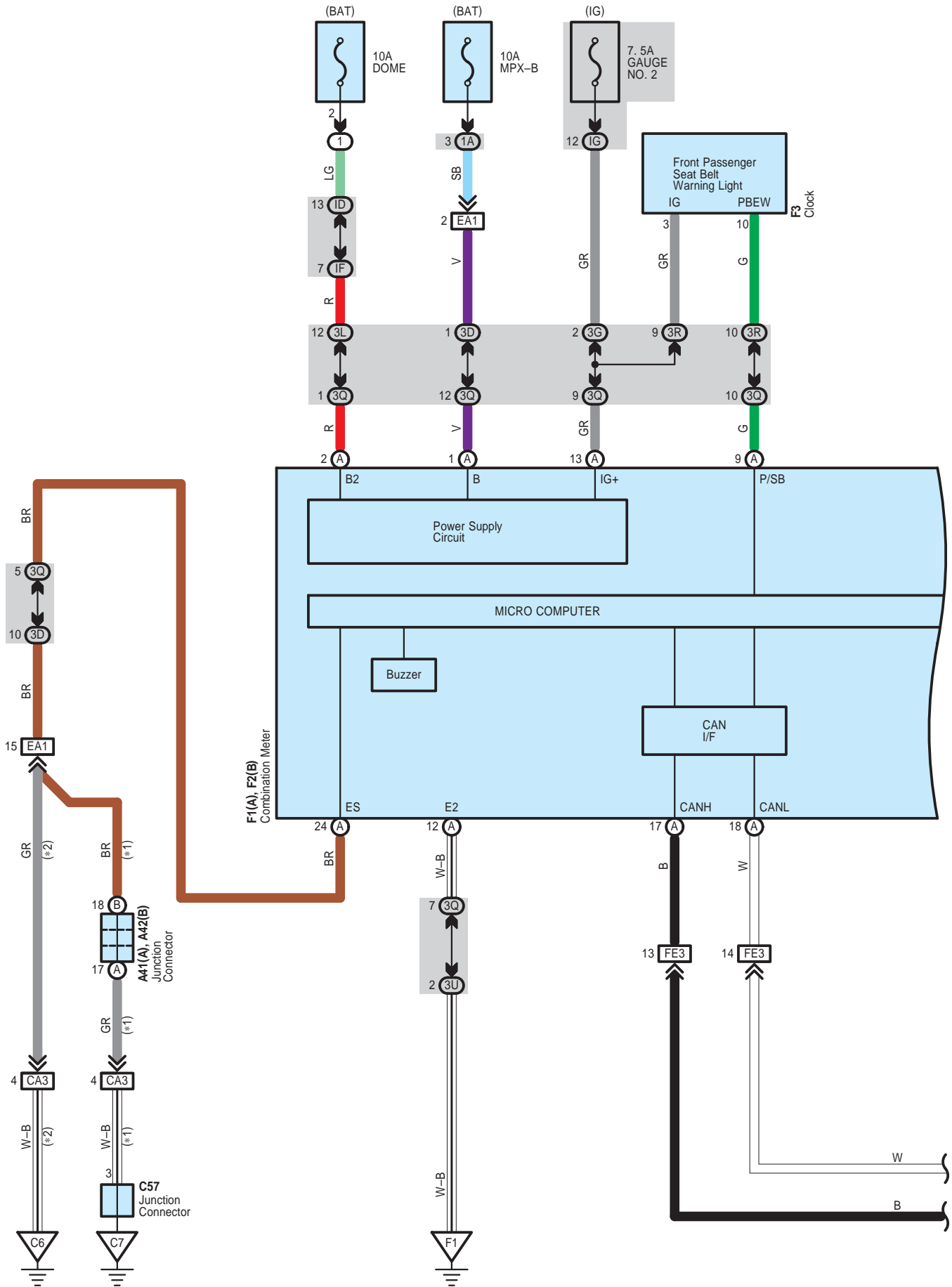

- \* 1 : 2GR-FE
- \* 2 : 2AZ-FE
- \* 3 : w/ VSC TMC Made
- \* 4 : w/ VSC TMMK Made
- \* 5 : w/o VSC

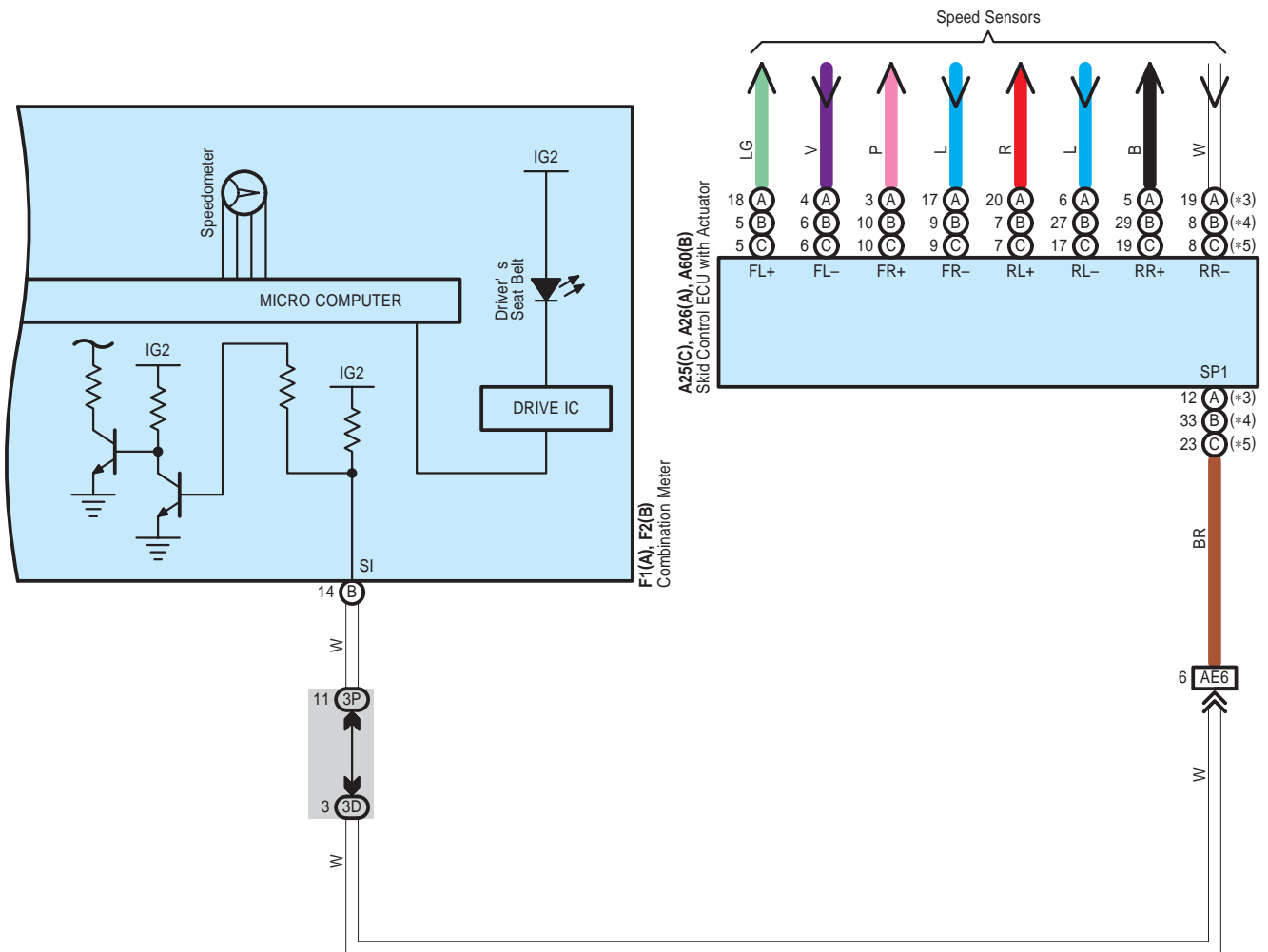



# Key Reminder without Smart Key System and Seat Belt Warning

- \* 6 : w/o Smart Key System
- \* 7 : w/ Power Seat
- \* 8 : w/o Power Seat
- \* 9 : TMC Made
- \* 10 : TMMK Made

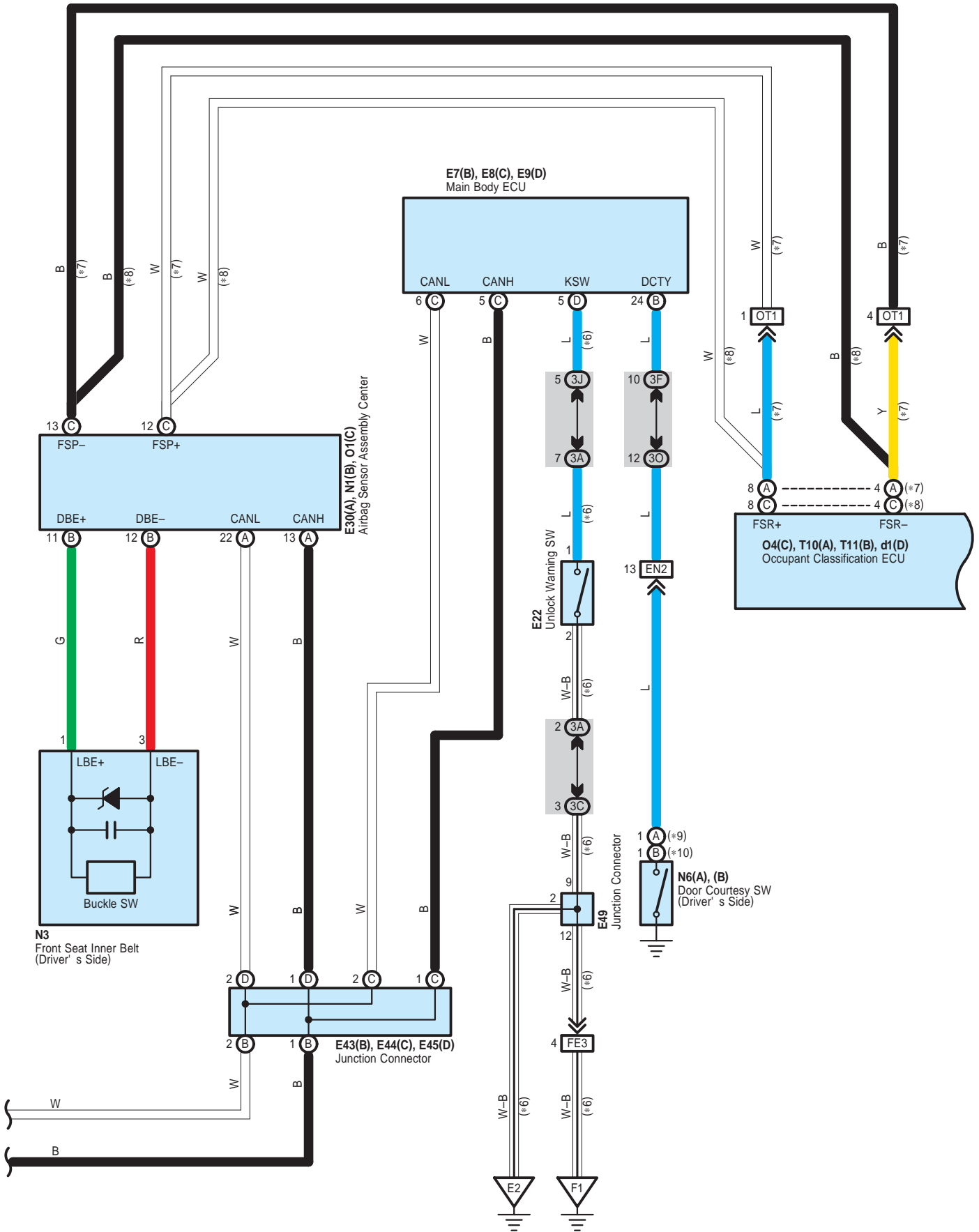

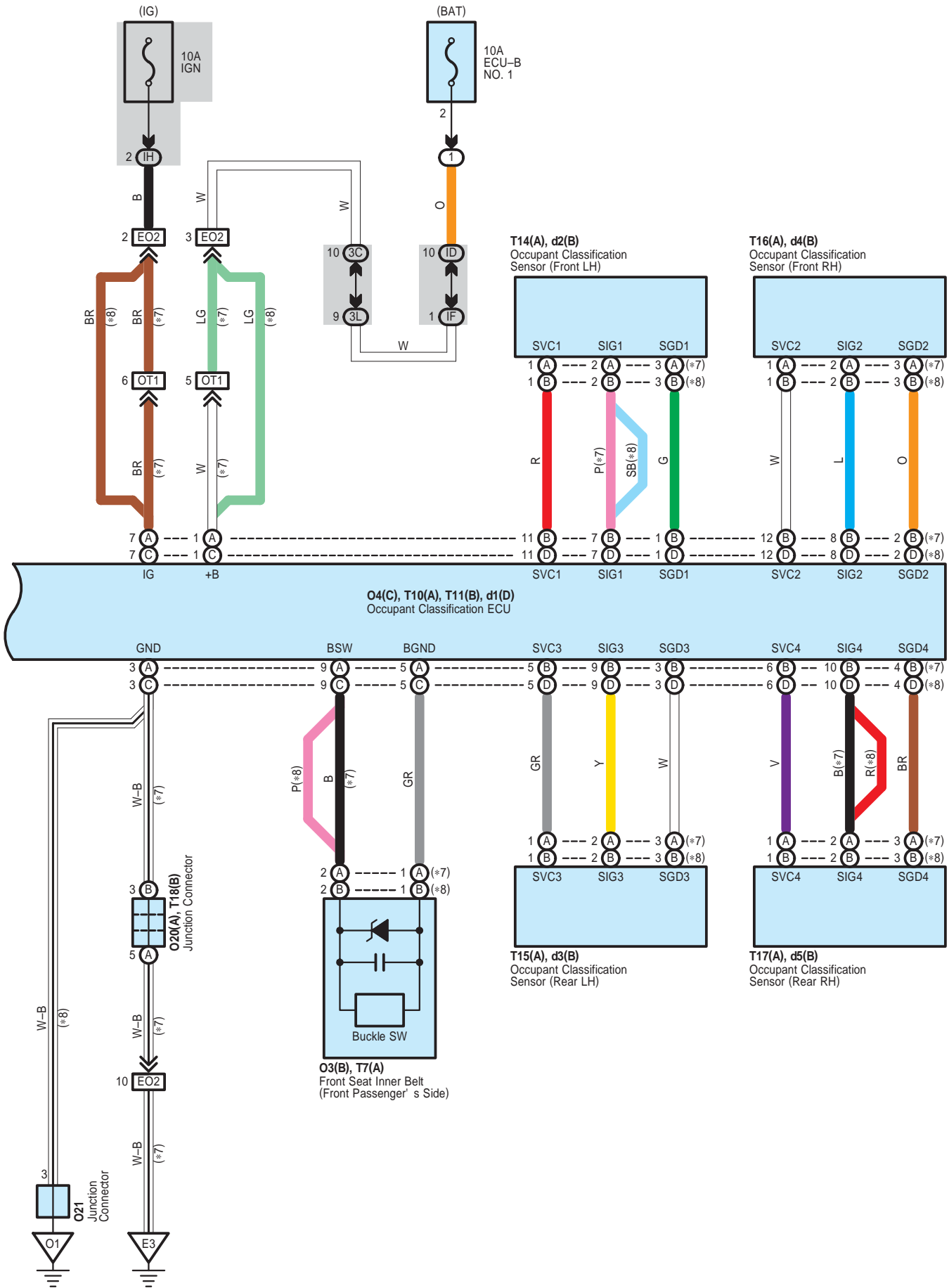

# Key Reminder without Smart Key System and Seat Belt Warning

## System Outline

### Key Reminder Operation

With the ignition key inserted in the key cylinder (Unlock warning SW on), the ignition SW still off and driver's door open (Door courtesy SW on), when a signal is input to the combination meter, the combination meter operates key reminder buzzer sounds.

### Seat Belt Warning Operation

When the driver has not fastened the seat belt while the power SW is pushed to IG ON position (Power SW type), or while the ignition SW is ON (Ignition SW type), the driver seat belt warning light blinks, and a warning buzzer comes on.

Also, in the front passenger seat, a sensor recognizes passenger, and when the passenger has not fastened the seat belt, the front passenger seat belt warning light blinks.

## ○ : Parts Location

| Code |   | See Page                   | Code |   | See Page | Code |   | See Page |
|------|---|----------------------------|------|---|----------|------|---|----------|
| A25  | C | 48 (2GR-FE)<br>52 (2AZ-FE) | E44  | C | 57       | O21  |   | 60       |
|      |   |                            | E45  | D | 57       | T7   | A | 62 (*1)  |
| A26  | A | 48 (2GR-FE)<br>52 (2AZ-FE) | E49  |   | 57       | T10  | A | 62 (*1)  |
|      |   |                            | F1   | A | 58       | T11  | B | 62 (*1)  |
| A41  | A | 59                         | F2   | B | 58       | T14  | A | 62 (*1)  |
| A42  | B | 59                         | F3   |   | 58       | T15  | A | 62 (*1)  |
| A60  | B | 49 (2GR-FE)<br>53 (2AZ-FE) | N1   | B | 59       | T16  | A | 62 (*1)  |
|      |   |                            | N3   |   | 62 (*1)  | T17  | A | 62 (*1)  |
| C57  |   | 51 (2GR-FE)                |      |   | 63 (*2)  | T18  | B | 62 (*1)  |
| E7   | B | 56                         | N6   | A | 60       | d1   | D | 63 (*2)  |
| E8   | C | 56                         |      | B | 60       | d2   | B | 63 (*2)  |
| E9   | D | 56                         | O1   | C | 59       | d3   | B | 63 (*2)  |
| E22  |   | 56                         | O3   | B | 63 (*2)  | d4   | B | 63 (*2)  |
| E30  | A | 56                         | O4   | C | 63 (*2)  | d5   | B | 63 (*2)  |
| E43  | B | 57                         | O20  | A | 62 (*1)  |      |   |          |

## ○ : Relay Blocks

| Code | See Page | Relay Blocks (Relay Block Location)       |
|------|----------|---|
| 1    | 22       | Engine Room R/B (Engine Compartment Left) |

## ○ : Junction Block and Wire Harness Connector

| Code | See Page | Junction Block and Wire Harness (Connector Location)                   |
|------|----------|--|
| 1A   | 25       | Engine Room Main Wire and Engine Room J/B (Engine Compartment Left)    |
| 3A   | 36       | Instrument Panel Wire and J/B No.3 (Behind the Combination Meter)      |
| 3C   |          |  |
| 3D   |          |  |
| 3F   |          |  |
| 3G   |          |  |
| 3J   |          |  |
| 3L   |          |  |
| 3O   |          |  |
| 3P   | 36       | Instrument Panel No.2 Wire and J/B No.3 (Behind the Combination Meter) |
| 3Q   |          |  |
| 3R   |          |  |
| 3U   |          |  |
| ID   | 30       | Engine Room Main Wire and Instrument Panel J/B (Cowl Side Left)        |
| IF   | 30       | Instrument Panel Wire and Instrument Panel J/B (Cowl Side Left)        |
| IG   | 31       |  |
| IH   |          |  |

\* 1 : w/ Power Seat      \* 2 : w/o Power Seat

 : Connector Joining Wire Harness and Wire Harness

| Code | See Page    | Joining Wire Harness and Wire Harness (Connector Location)                                |
|------|-------------|---|
| AE6  | 66          | Engine Room Main Wire and Instrument Panel Wire (Instrument Panel Right)                  |
| CA3  | 64 (2GR-FE) | Engine Wire and Engine Room Main Wire (Inside of the Engine Room R/B and Engine Room J/B) |
|      | 65 (2AZ-FE) |   |
| EA1  | 66          | Instrument Panel Wire and Engine Room Main Wire (Left Kick Panel)                         |
| EN2  | 66          | Instrument Panel Wire and Floor Wire (Left Kick Panel)                                    |
| EO2  | 66          | Instrument Panel Wire and Floor No.2 Wire (Right Kick Panel)                              |
| FE3  | 66          | Instrument Panel No.2 Wire and Instrument Panel Wire (Instrument Panel Center)            |
| OT1  | 68 (*1)     | Floor No.2 Wire and Front Seat RH Wire (Under the Front Passenger's Seat)                 |

 : Ground Points

| Code | See Page    | Ground Points Location          |
|------|-------------|---------------------------------|
| C6   | 65 (2AZ-FE) | Cylinder Block                  |
| C7   | 64 (2GR-FE) | Left Side of the Cylinder Block |
| E2   | 66          | Instrument Panel Brace LH       |
| E3   | 66          | Instrument Panel Right          |
| F1   | 66          | Instrument Panel Left           |
| O1   | 67          | Right Rear Quarter Panel        |

\* 1 : w/ Power Seat      \* 2 : w/o Power Seat

# Wiper and Washer

E19(A), E20(B)  
Windshield Wiper SW Assembly

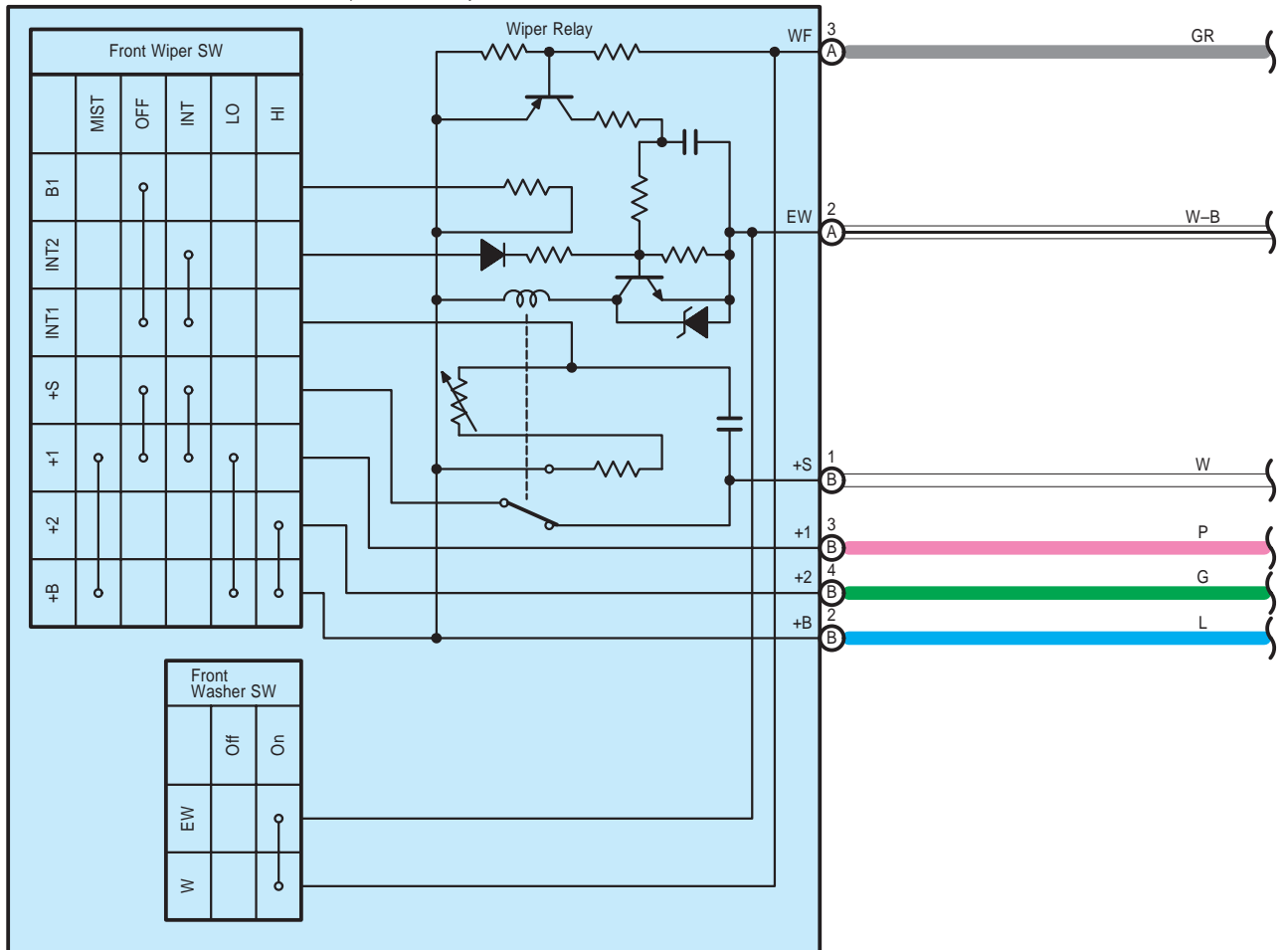

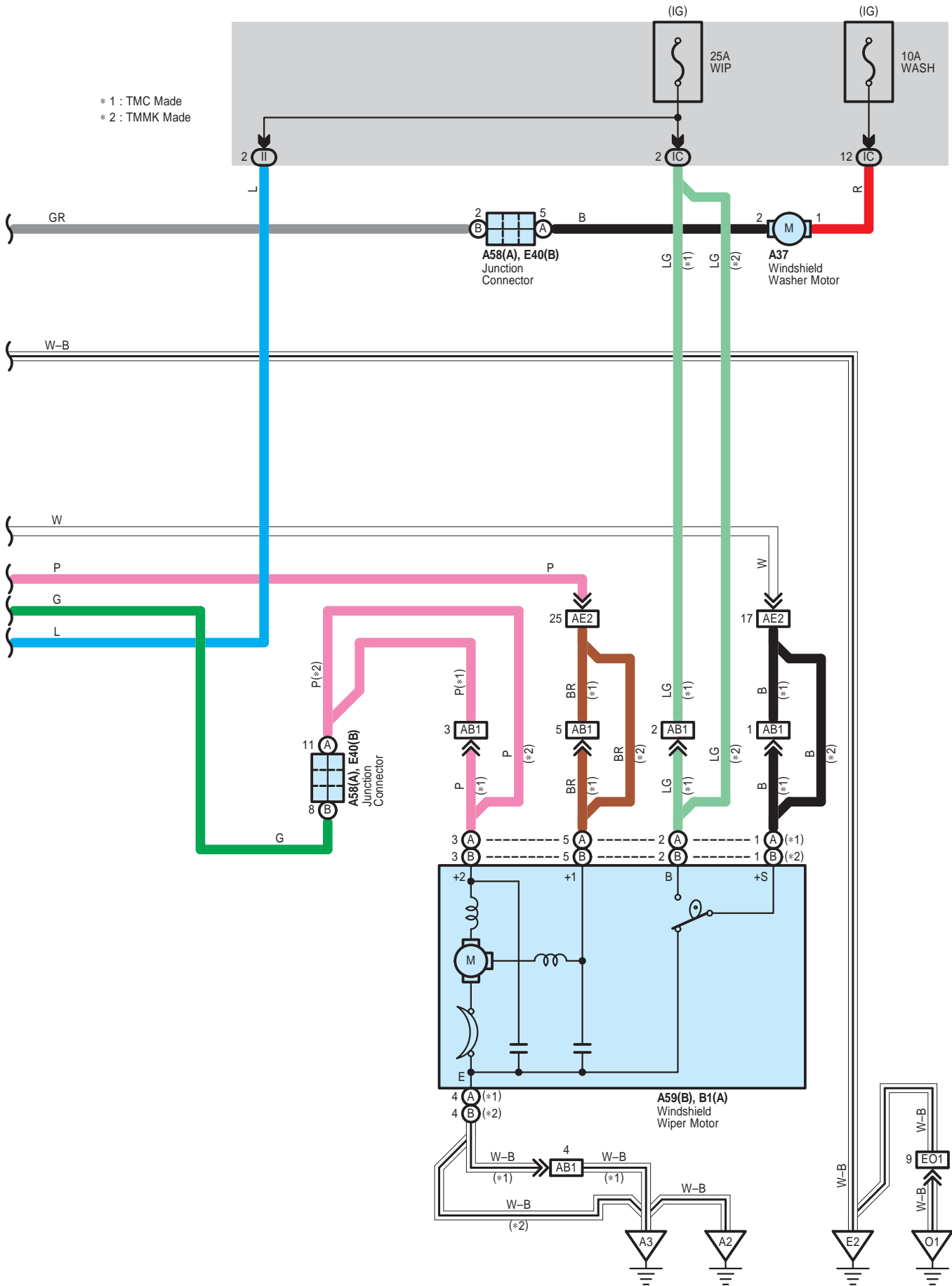

# Wiper and Washer

## ○ : Parts Location

| Code |   | See Page    | Code |   | See Page    | Code |   | See Page |
|------|---|-------------|------|---|-------------|------|---|----------|
| A37  |   | 48 (2GR-FE) | A59  | B | 53 (2AZ-FE) | E20  | B | 56       |
|      |   | 52 (2AZ-FE) | B1   | A | 49 (2GR-FE) | E40  | B | 57       |
| A58  | A | 59          |      |   |             |      |   |          |
| A59  | B | 49 (2GR-FE) | E19  | A | 56          |      |   |          |

## ○ : Junction Block and Wire Harness Connector

| Code | See Page | Junction Block and Wire Harness (Connector Location)            |
|------|----------|---|
| IC   | 30       | Engine Room Main Wire and Instrument Panel J/B (Cowl Side Left) |
| II   | 31       | Instrument Panel Wire and Instrument Panel J/B (Cowl Side Left) |

## □ : Connector Joining Wire Harness and Wire Harness

| Code | See Page    | Joining Wire Harness and Wire Harness (Connector Location)                               |
|------|-------------|--|
| AB1  | 64 (2GR-FE) | Engine Room Main Wire and Engine Room No.2 Wire (Near the Windshield Wiper Motor)        |
|      | 65 (2AZ-FE) |  |
| AE2  | 66          | Engine Room Main Wire and Instrument Panel Wire (Right Side of the Instrument Panel J/B) |

## ▽ : Ground Points

| Code | See Page    | Ground Points Location    |
|------|-------------|---------------------------|
| A2   | 64 (2GR-FE) | Front Left Fender         |
|      | 65 (2AZ-FE) |                           |
| A3   | 66          | Left Cowl Side Panel      |
| E2   | 66          | Instrument Panel Brace LH |
| O1   | 67          | Right Rear Quarter Panel  |





# Power Outlet

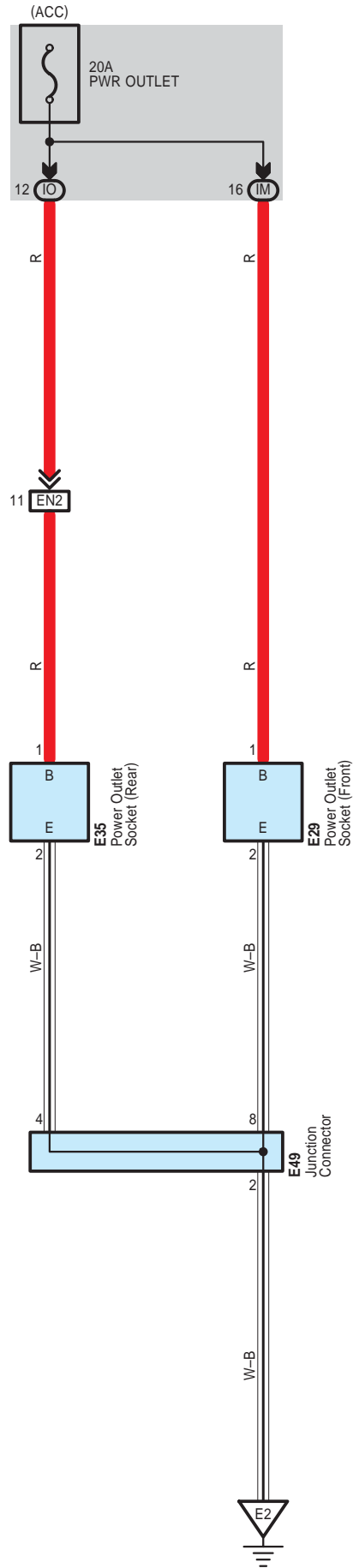

 : **Parts Location**

| Code | See Page | Code | See Page | Code | See Page |
|------|----------|------|----------|------|----------|
| E29  | 56       | E35  | 57       | E49  | 57       |

 : **Junction Block and Wire Harness Connector**

| Code | See Page | Junction Block and Wire Harness (Connector Location)            |
|------|----------|---|
| IM   | 30       | Instrument Panel Wire and Instrument Panel J/B (Cowl Side Left) |
| IO   | 30       | Floor Wire and Instrument Panel J/B (Cowl Side Left)            |

 : **Connector Joining Wire Harness and Wire Harness**

| Code | See Page | Joining Wire Harness and Wire Harness (Connector Location) |
|------|----------|--|
| EN2  | 66       | Instrument Panel Wire and Floor Wire (Left Kick Panel)     |

 : **Ground Points**

| Code | See Page | Ground Points Location    |
|------|----------|---------------------------|
| E2   | 66       | Instrument Panel Brace LH |

# Clock

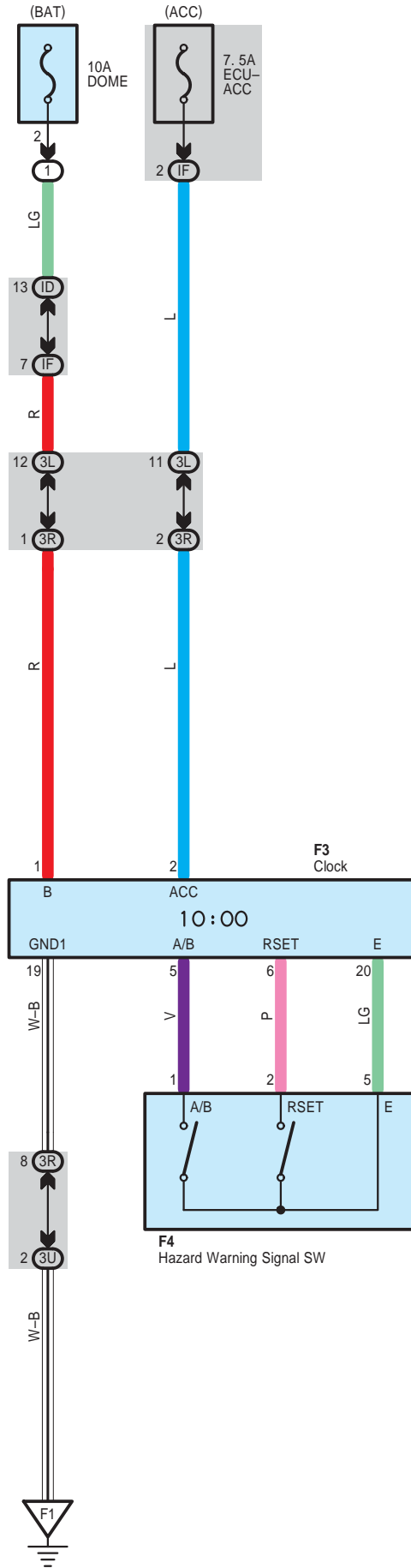

 : **Parts Location**

| Code | See Page | Code | See Page | Code | See Page |
|------|----------|------|----------|------|----------|
| F3   | 58       | F4   | 58       |      |          |

 : **Relay Blocks**

| Code | See Page | Relay Blocks (Relay Block Location)       |
|------|----------|---|
| 1    | 22       | Engine Room R/B (Engine Compartment Left) |

 : **Junction Block and Wire Harness Connector**

| Code | See Page | Junction Block and Wire Harness (Connector Location)                   |
|------|----------|--|
| 3L   | 36       | Instrument Panel Wire and J/B No.3 (Behind the Combination Meter)      |
| 3R   | 36       | Instrument Panel No.2 Wire and J/B No.3 (Behind the Combination Meter) |
| 3U   |          |  |
| ID   | 30       | Engine Room Main Wire and Instrument Panel J/B (Cowl Side Left)        |
| IF   | 30       | Instrument Panel Wire and Instrument Panel J/B (Cowl Side Left)        |

 : **Ground Points**

| Code | See Page | Ground Points Location |
|------|----------|------------------------|
| F1   | 66       | Instrument Panel Left  |

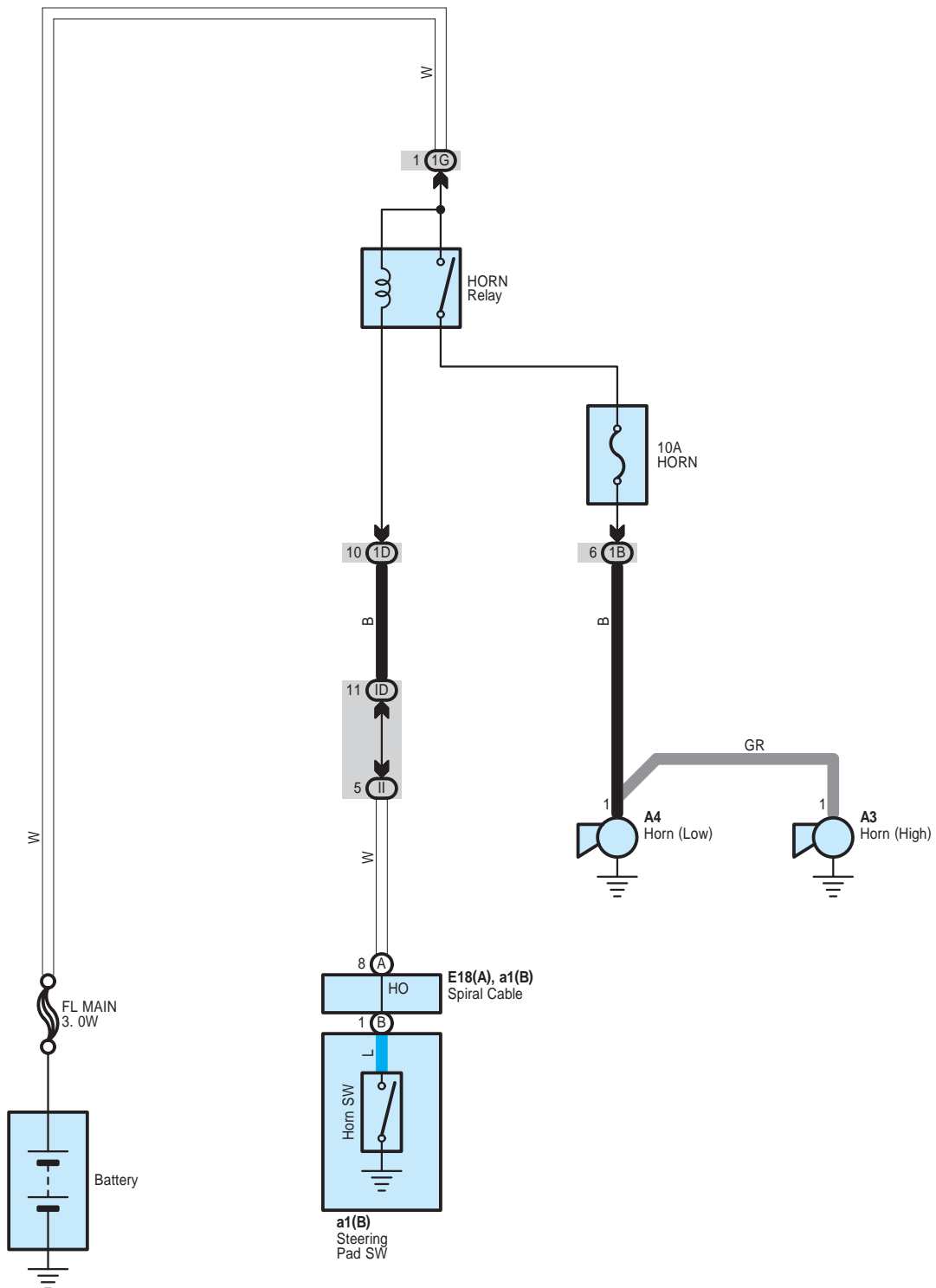

**○ : Parts Location**

| Code | See Page    | Code | See Page    | Code | See Page |
|------|-------------|------|-------------|------|----------|
| A3   | 48 (2GR-FE) | A4   | 48 (2GR-FE) | E18  | A 56     |
|      | 52 (2AZ-FE) |      | 52 (2AZ-FE) | a1   | B 59     |

**○ : Junction Block and Wire Harness Connector**

| Code | See Page | Junction Block and Wire Harness (Connector Location)                |
|------|----------|---|
| 1B   | 25       | Engine Room Main Wire and Engine Room J/B (Engine Compartment Left) |
| 1D   |          |   |
| 1G   |          |   |
| ID   | 30       | Engine Room Main Wire and Instrument Panel J/B (Cowl Side Left)     |
| II   | 31       | Instrument Panel Wire and Instrument Panel J/B (Cowl Side Left)     |

# Power Window

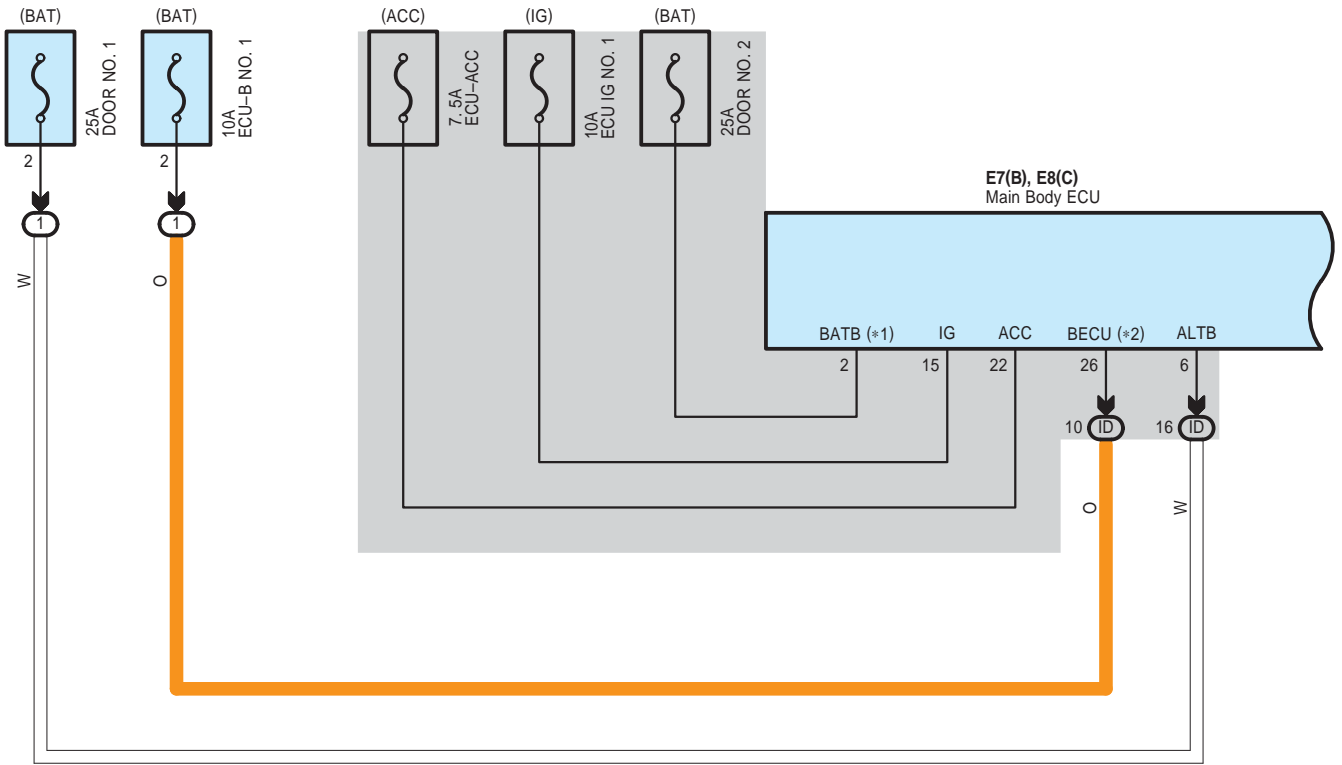

- \* 1 : w/ Smart Key System
- \* 2 : w/o Smart Key System
- \* 3 : TMC Made
- \* 4 : TMMK Made

E7(B), E8(C)  
Main Body ECU

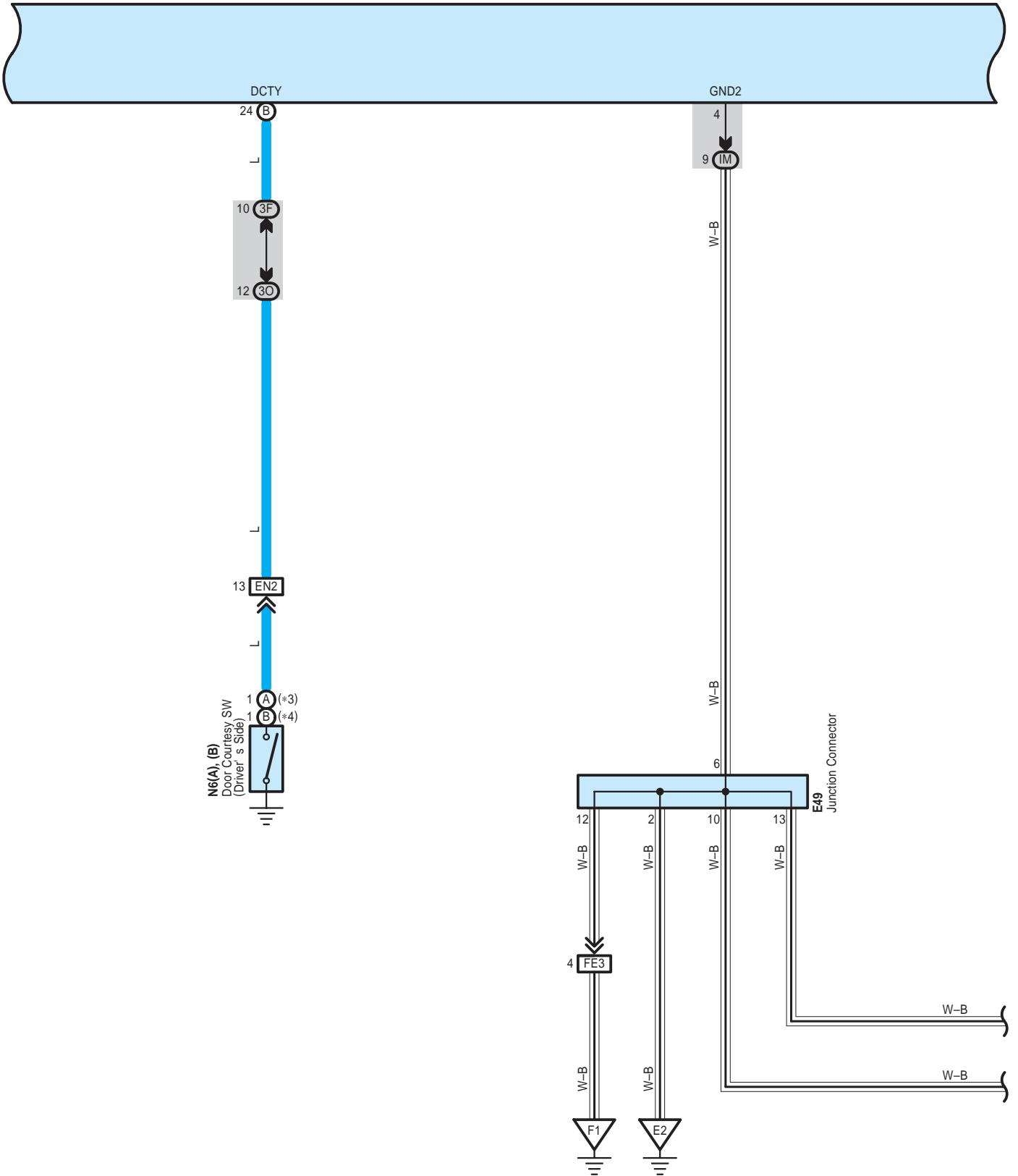



# Power Window

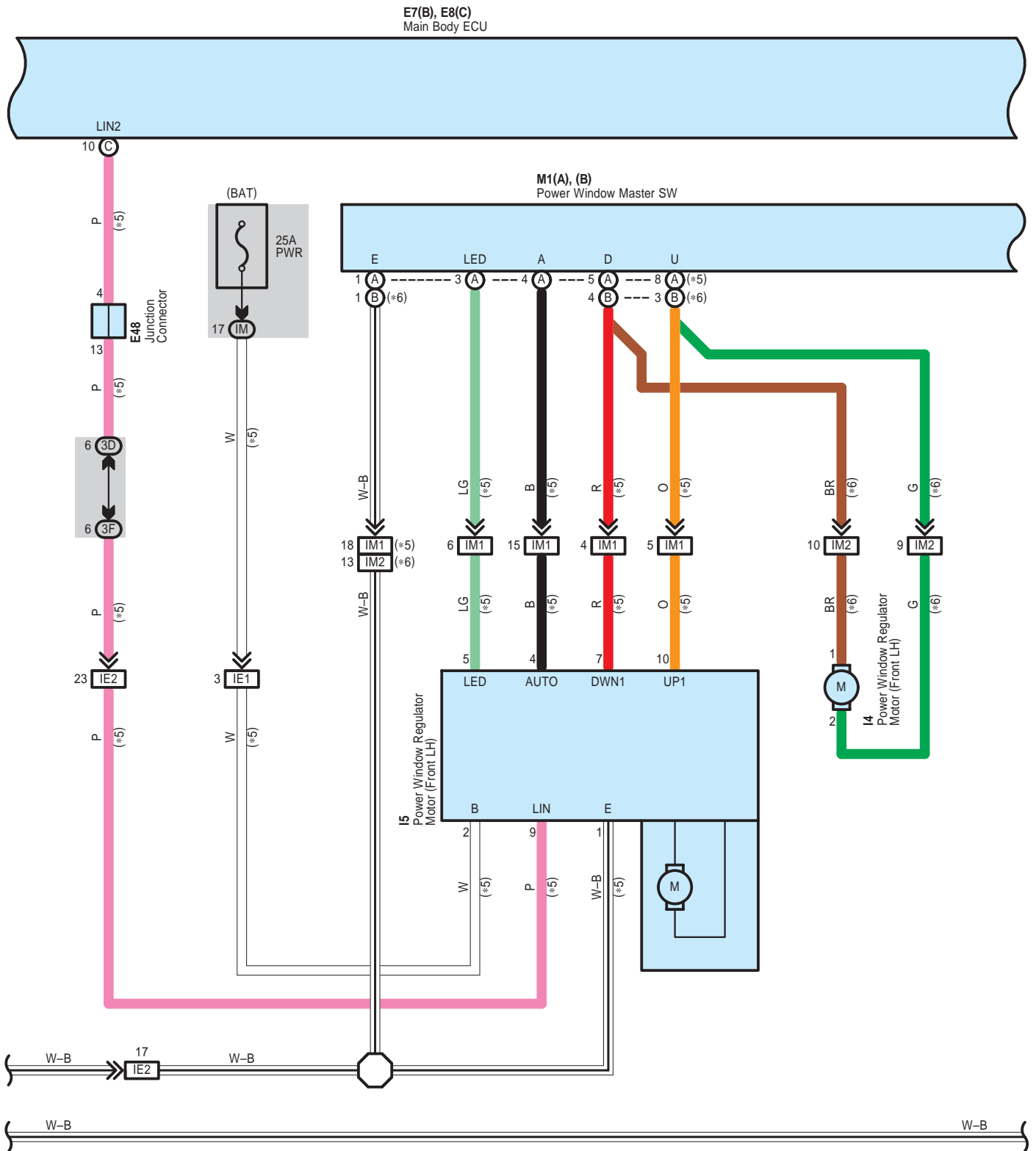

\* 5 : w/ Jam Protection  
 \* 6 : w/o Jam Protection

E7(B), E8(C)  
 Main Body ECU

M1(A), (B)  
 Power Window Master SW

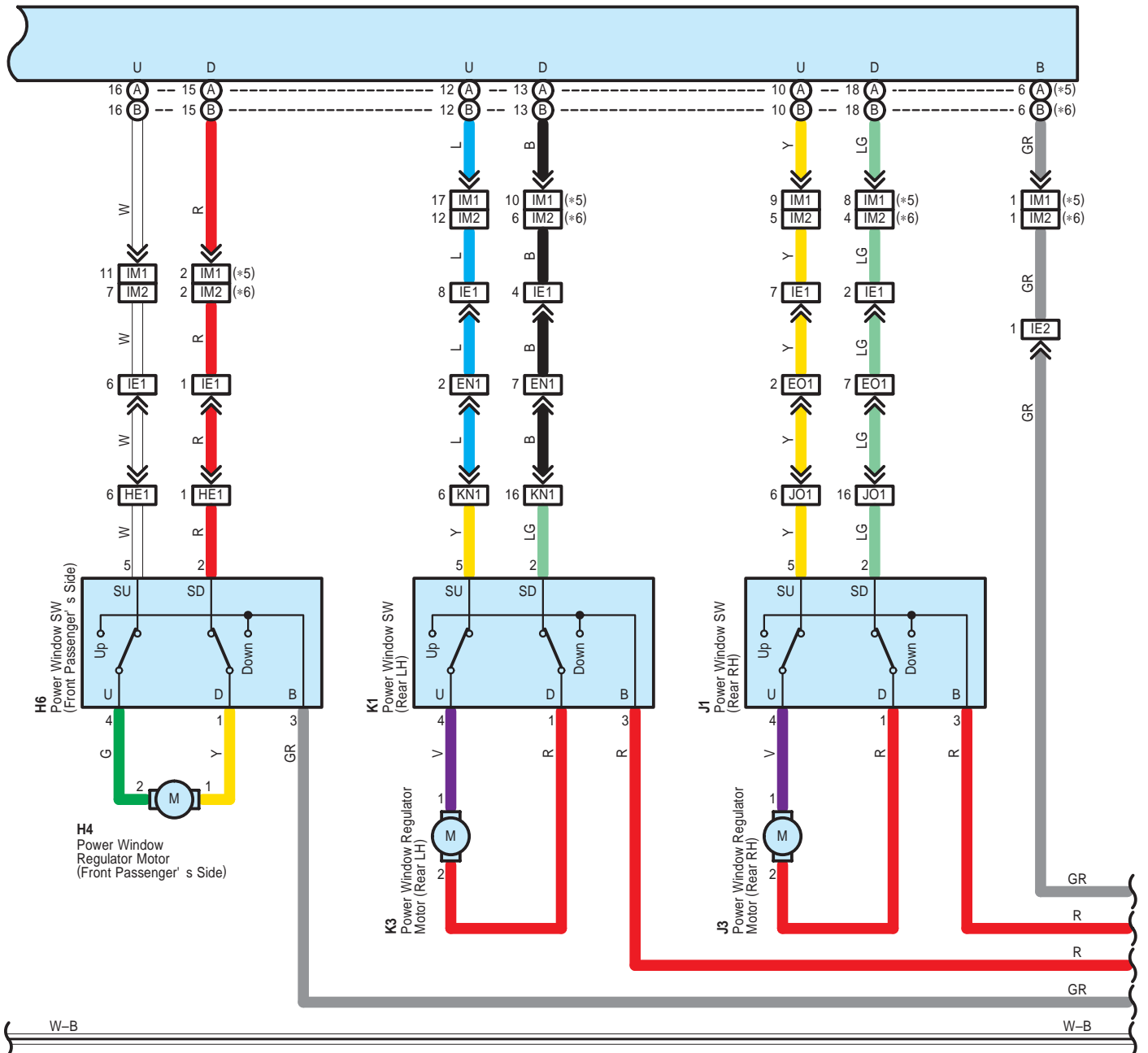

# Power Window

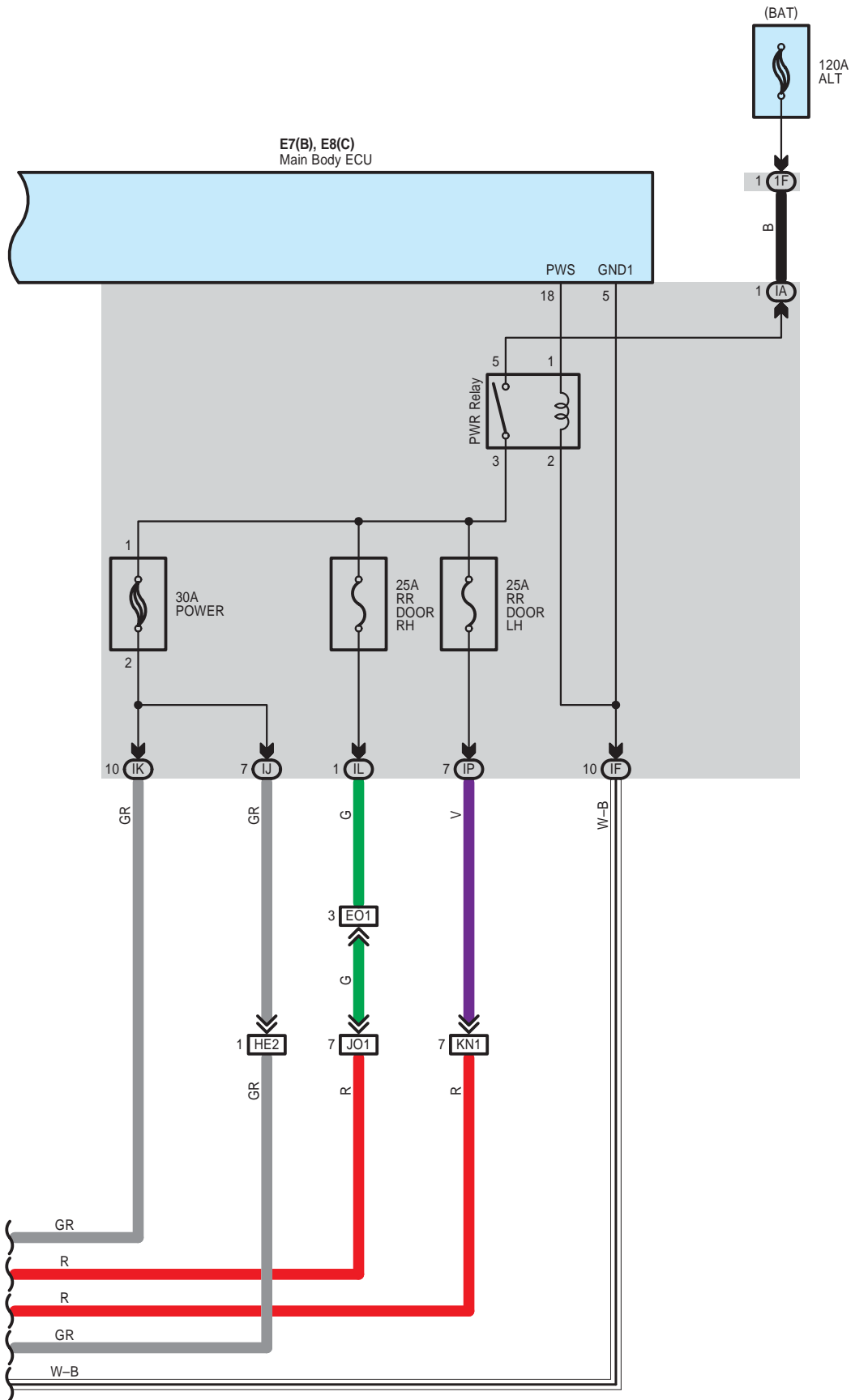

## System Outline

### 1. Manual Down or Up Operation

When the power window master SW is pushed one step, the motor rotates to open the window.

When the power window master SW is pulled up one step, the motor rotates in the opposite direction, to close the window.

All the other windows can be opened/closed as well, by the operation of the power window master SW or respective power window SW.

### 2. Auto Down or Up Operation

When the power window master SW is pushed two steps, the motor rotates to open the window automatically.

When the power window master SW is pulled up two steps, the motor rotates to close the window automatically. (w/ jam protection)

### 3. Jam Protection Function

When any foreign object gets caught during power window UP operation, the motor rotates in the opposite direction to open the window.

## ○ : Parts Location

| Code | See Page | Code | See Page | Code | See Page |    |    |
|------|----------|------|----------|------|----------|----|----|
| E7   | B        | 56   | I4       | 61   | M1       | A  | 61 |
| E8   | C        | 56   | I5       | 61   |          | B  | 61 |
| E48  | 57       | J1   | 61       | N6   | A        | 60 |    |
| E49  | 57       | J3   | 61       |      | B        | 60 |    |
| H4   | 61       | K1   | 61       |      |          |    |    |
| H6   | 61       | K3   | 61       |      |          |    |    |

## ○ : Relay Blocks

| Code | See Page | Relay Blocks (Relay Block Location)       |
|------|----------|---|
| 1    | 22       | Engine Room R/B (Engine Compartment Left) |

## ○ : Junction Block and Wire Harness Connector

| Code | See Page | Junction Block and Wire Harness (Connector Location)                |
|------|----------|---|
| 1F   | 22       | Engine Room Main Wire and Engine Room J/B (Engine Compartment Left) |
| 3D   | 36       | Instrument Panel Wire and J/B No.3 (Behind the Combination Meter)   |
| 3F   |          |   |
| 3O   |          |   |
| IA   | 30       | Engine Room Main Wire and Instrument Panel J/B (Cowl Side Left)     |
| ID   |          |   |
| IF   | 30       | Instrument Panel Wire and Instrument Panel J/B (Cowl Side Left)     |
| IJ   |          |   |
| IK   |          |   |
| IL   |          |   |
| IM   |          |   |
| IP   | 30       | Floor Wire and Instrument Panel J/B (Cowl Side Left)                |

# Power Window

 : Connector Joining Wire Harness and Wire Harness

| Code | See Page | Joining Wire Harness and Wire Harness (Connector Location)                     |
|------|----------|--|
| EN1  | 66       | Instrument Panel Wire and Floor Wire (Left Kick Panel)                         |
| EN2  |          |  |
| EO1  | 66       | Instrument Panel Wire and Floor No.2 Wire (Right Kick Panel)                   |
| FE3  | 66       | Instrument Panel No.2 Wire and Instrument Panel Wire (Instrument Panel Center) |
| HE1  | 66       | Front Door RH Wire and Instrument Panel Wire (Right Kick Panel)                |
| HE2  |          |  |
| IE1  | 66       | Front Door LH Wire and Instrument Panel Wire (Left Kick Panel)                 |
| IE2  |          |  |
| IM1  | 67       | Front Door LH Wire and Front Door LH No.2 Wire (Inside of the Front Door LH)   |
| IM2  |          |  |
| JO1  | 67       | Rear Door No.1 Wire and Floor No.2 Wire (Right Center Pillar)                  |
| KN1  | 67       | Rear Door No.2 Wire and Floor Wire (Left Center Pillar)                        |

 : Ground Points

| Code | See Page | Ground Points Location    |
|------|----------|---------------------------|
| E2   | 66       | Instrument Panel Brace LH |
| F1   | 66       | Instrument Panel Left     |



# Door Lock Control and Luggage Compartment Door Opener

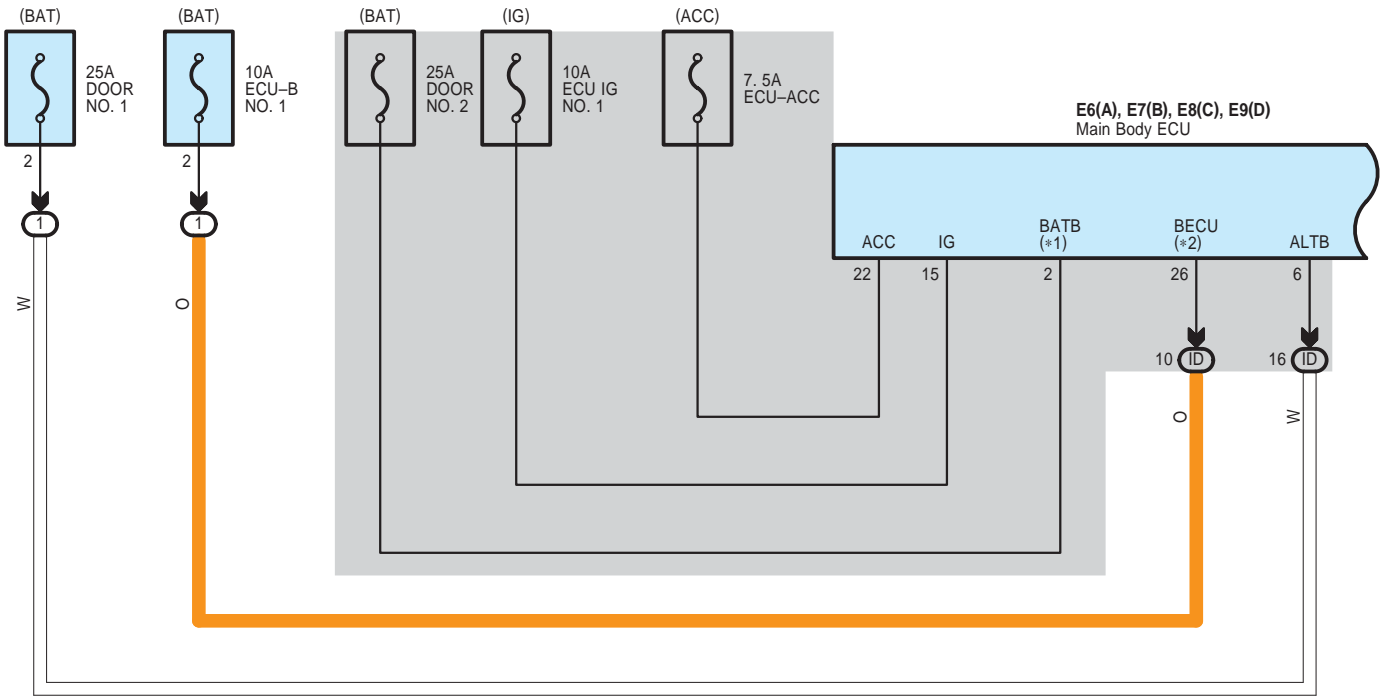

- \* 1 : w/ Smart Key System
- \* 2 : w/o Smart Key System
- \* 3 : TMC Made
- \* 4 : TMMK Made

E6(A), E7(B), E8(C), E9(D)  
Main Body ECU

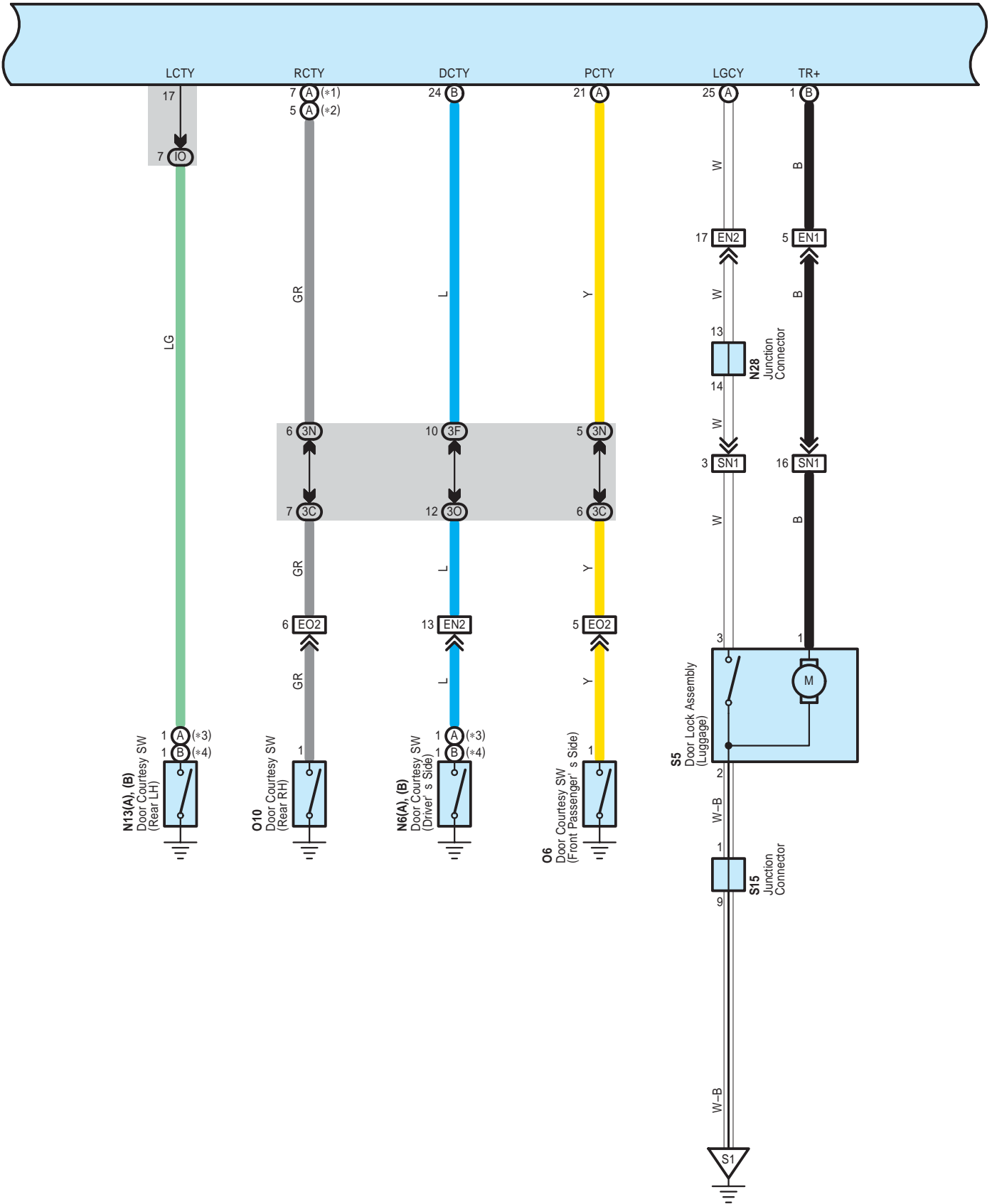



# Door Lock Control and Luggage Compartment Door Opener

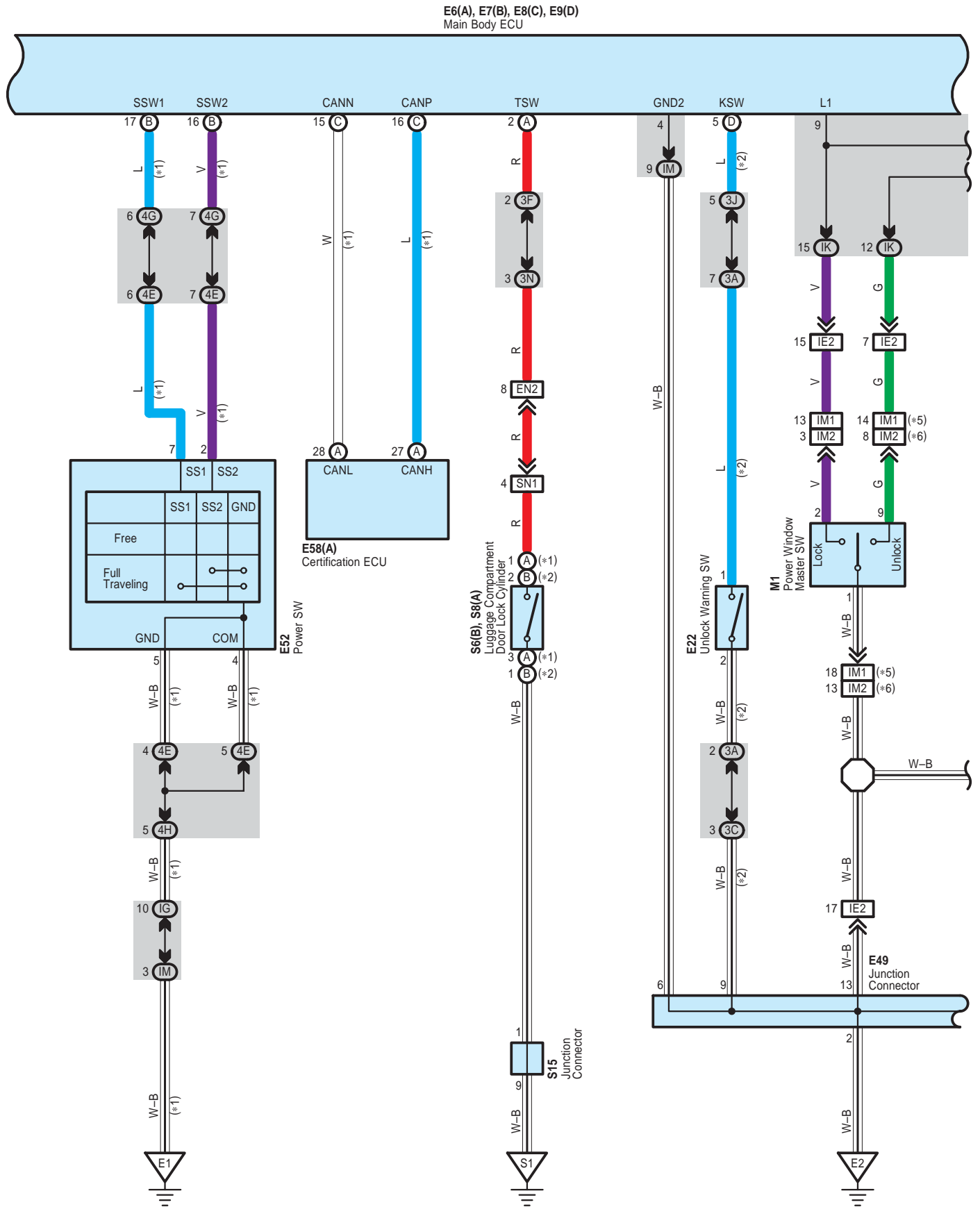

- \* 1 : w/ Smart Key System
- \* 2 : w/o Smart Key System
- \* 5 : w/ Jam Protection
- \* 6 : w/o Jam Protection

**E6(A), E7(B), E8(C), E9(D)**  
Main Body ECU

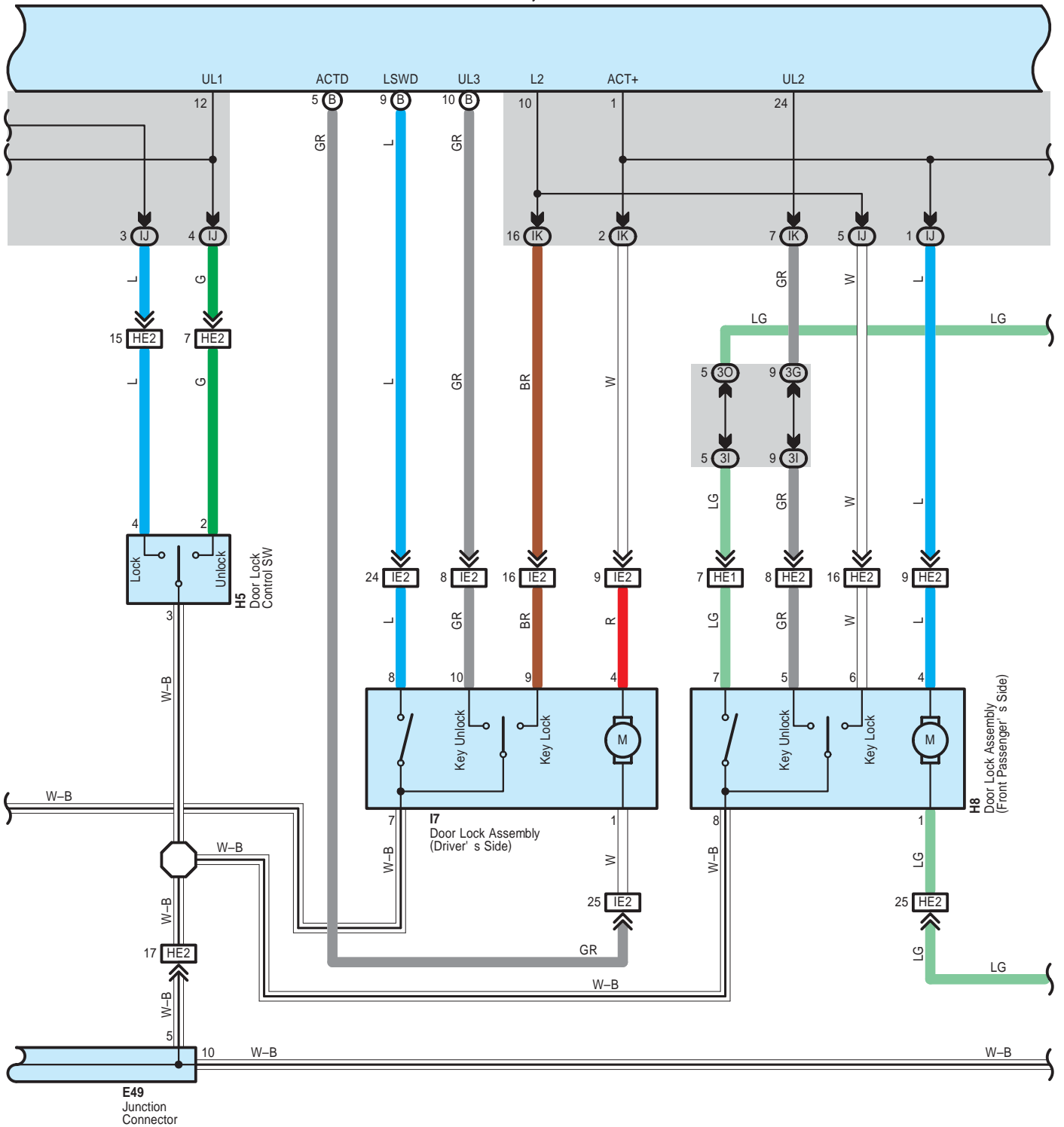

# Door Lock Control and Luggage Compartment Door Opener

- \* 1 : w/ Smart Key System
- \* 2 : w/o Smart Key System
- \* 7 : 2GR-FE
- \* 8 : 2AZ-FE

E6(A), E7(B), E8(C), E9(D)  
Main Body ECU

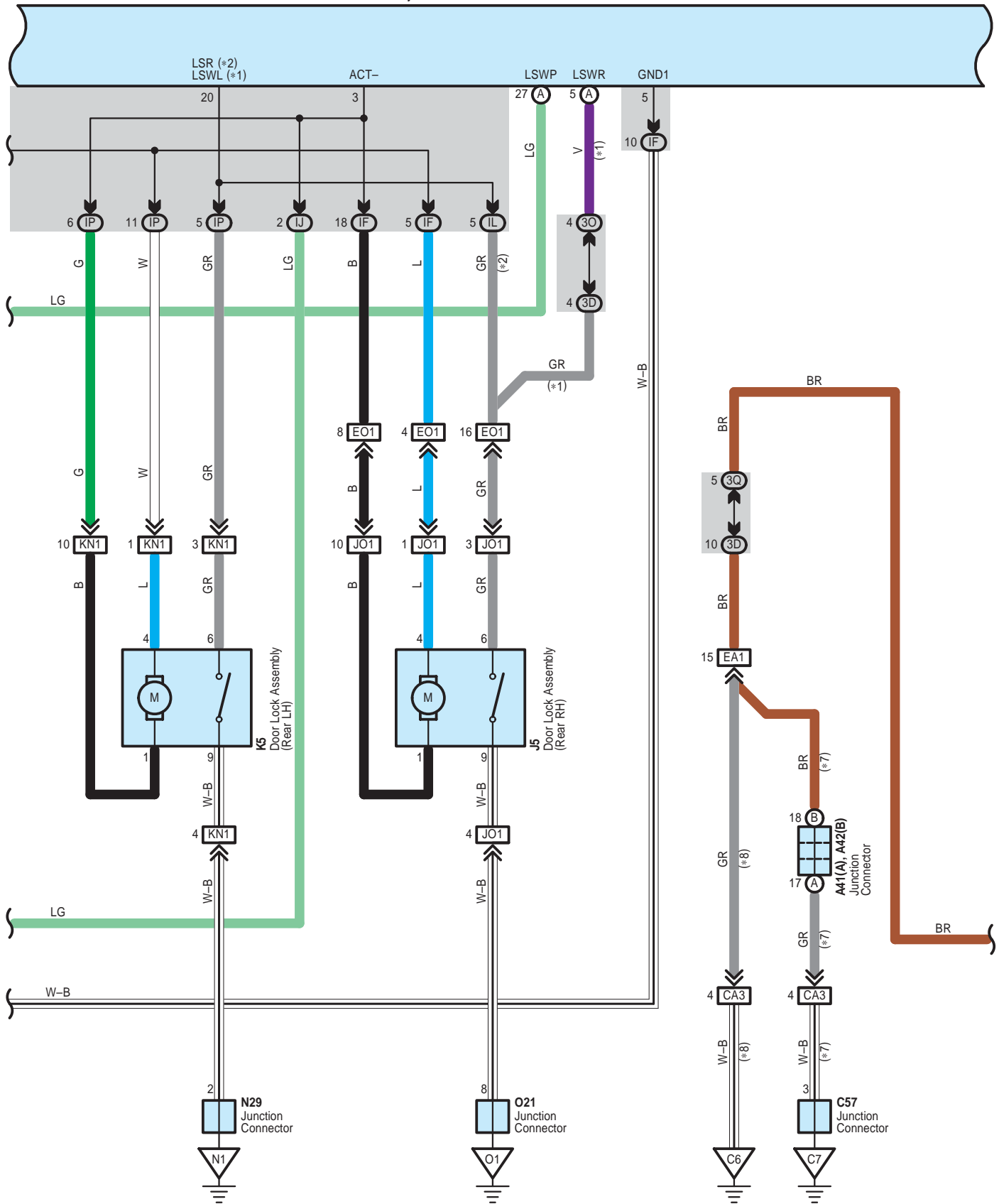

E6(A), E7(B), E8(C), E9(D)  
Main Body ECU

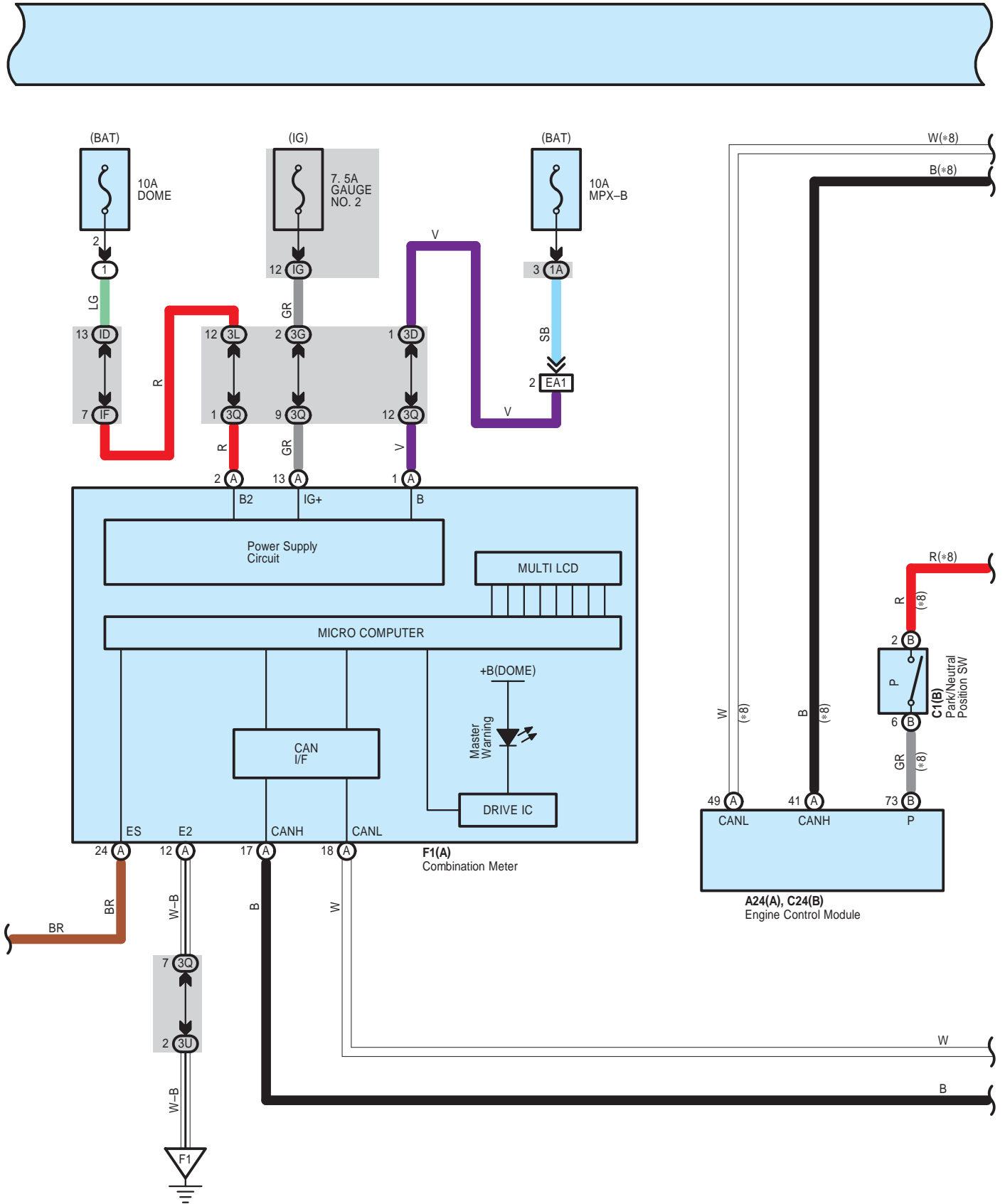

# Door Lock Control and Luggage Compartment Door Opener

\* 7 : 2GR-FE  
\* 8 : 2AZ-FE

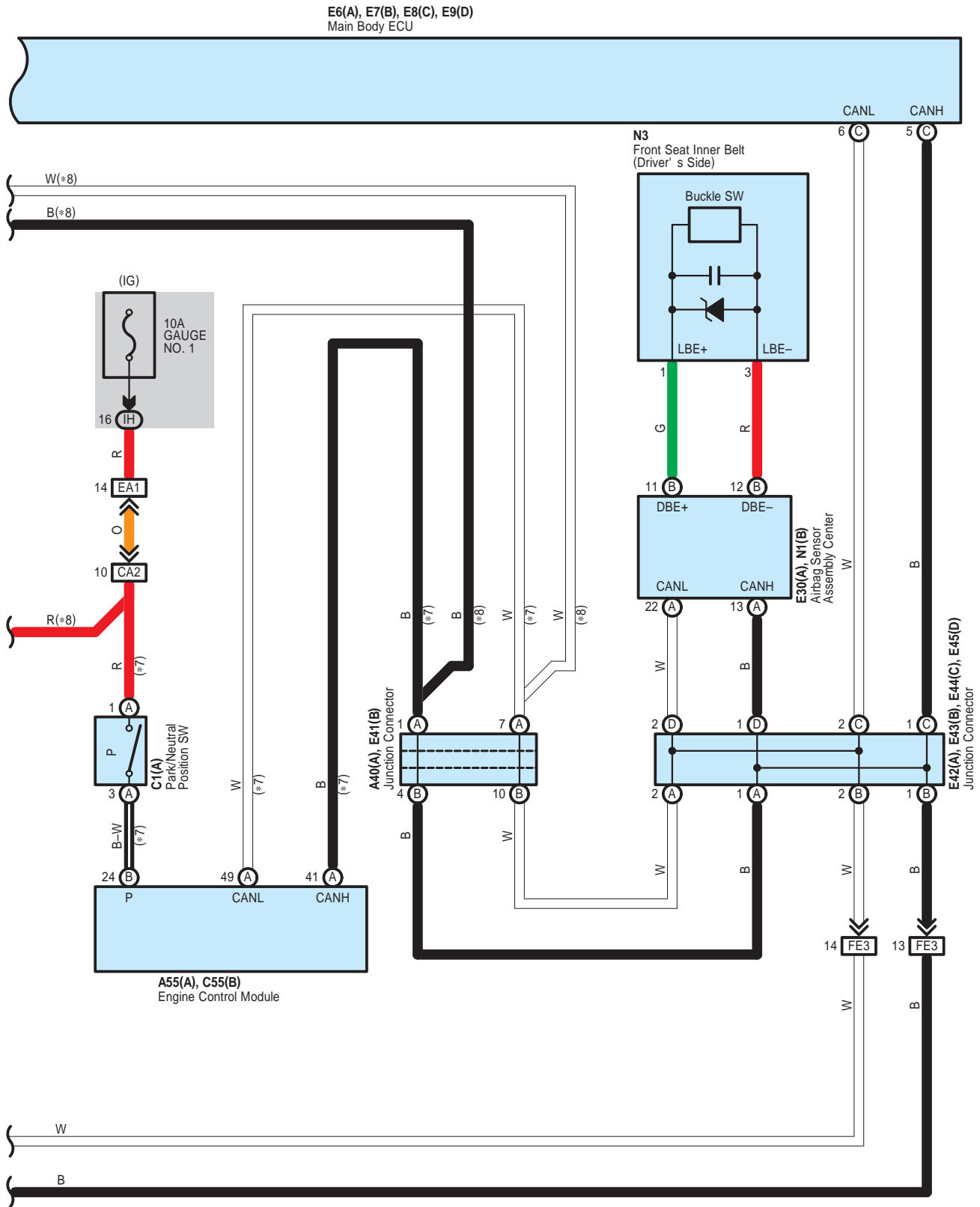

## System Outline

### 1. Manual Unlock Operation

When the door lock control SW of the driver's or passenger's side door is pushed to UNLOCK, the door lock will unlock.

### 2. Manual Lock Operation

When the door lock control SW of the driver's or passenger's side door is pushed to LOCK, the door lock will lock.

### 3. Door Key Unlock Operation

\* Unlock operation from driver's side door

When the driver's side door is unlocked once using the ignition key, only the driver's side door is unlocked. If this operation is repeated within 3 seconds, all the other doors are unlocked.

## ○ : Parts Location

| Code |   | See Page    | Code |   | See Page | Code |   | See Page |
|------|---|-------------|------|---|----------|------|---|----------|
| A24  | A | 52 (2AZ-FE) | E41  | B | 57       | N3   |   | 62 (*1)  |
| A40  | A | 59          | E42  | A | 57       |      |   | 63 (*2)  |
| A41  | A | 59          | E43  | B | 57       | N6   | A | 60       |
| A42  | B | 59          | E44  | C | 57       |      | B | 60       |
| A55  | A | 49 (2GR-FE) | E45  | D | 57       | N13  | A | 60       |
| C1   | A | 50 (2GR-FE) | E49  |   | 57       |      | B | 60       |
|      | B | 54 (2AZ-FE) | E52  |   | 57       | N28  |   | 60       |
| C24  | B | 55 (2AZ-FE) | E58  | A | 57       | N29  |   | 60       |
| C55  | B | 51 (2GR-FE) | F1   | A | 58       | O6   |   | 60       |
| C57  |   | 51 (2GR-FE) | H5   |   | 61       | O10  |   | 60       |
| E6   | A | 56          | H8   |   | 61       | O21  |   | 60       |
| E7   | B | 56          | I7   |   | 61       | S5   |   | 61       |
| E8   | C | 56          | J5   |   | 61       | S6   | B | 61       |
| E9   | D | 56          | K5   |   | 61       | S8   | A | 61       |
| E22  |   | 56          | M1   |   | 61       | S15  |   | 61       |
| E30  | A | 56          | N1   | B | 59       |      |   |          |

## ○ : Relay Blocks

| Code | See Page | Relay Blocks (Relay Block Location)       |
|------|----------|---|
| 1    | 22       | Engine Room R/B (Engine Compartment Left) |

\* 1 : w/ Power Seat      \* 2 : w/o Power Seat

# Door Lock Control and Luggage Compartment Door Opener

## : Junction Block and Wire Harness Connector

| Code | See Page | Junction Block and Wire Harness (Connector Location)                   |
|------|----------|--|
| 1A   | 25       | Engine Room Main Wire and Engine Room J/B (Engine Compartment Left)    |
| 3A   | 36       | Instrument Panel Wire and J/B No.3 (Behind the Combination Meter)      |
| 3C   |          |  |
| 3D   |          |  |
| 3F   |          |  |
| 3G   |          |  |
| 3I   |          |  |
| 3J   |          |  |
| 3L   |          |  |
| 3N   |          |  |
| 3O   |          |  |
| 3Q   | 36       | Instrument Panel No.2 Wire and J/B No.3 (Behind the Combination Meter) |
| 3U   |          |  |
| 4E   | 42       | Instrument Panel Wire and J/B No.4 (Instrument Panel Brace Center)     |
| 4G   |          |  |
| 4H   |          |  |
| ID   | 30       | Engine Room Main Wire and Instrument Panel J/B (Cowl Side Left)        |
| IF   | 30       | Instrument Panel Wire and Instrument Panel J/B (Cowl Side Left)        |
| IG   | 31       |  |
| IH   |          |  |
| IJ   | 30       |  |
| IK   |          |  |
| IL   |          |  |
| IM   |          |  |
| IO   | 30       |  |
| IP   |          |  |

## : Connector Joining Wire Harness and Wire Harness

| Code | See Page    | Joining Wire Harness and Wire Harness (Connector Location)                                |
|------|-------------|---|
| CA2  | 64 (2GR-FE) | Engine Wire and Engine Room Main Wire (Inside of the Engine Room R/B and Engine Room J/B) |
|      | 65 (2AZ-FE) |   |
| CA3  | 64 (2GR-FE) |   |
|      | 65 (2AZ-FE) |   |
| EA1  | 66          | Instrument Panel Wire and Engine Room Main Wire (Left Kick Panel)                         |
| EN1  | 66          | Instrument Panel Wire and Floor Wire (Left Kick Panel)                                    |
| EN2  |             |   |
| EO1  | 66          | Instrument Panel Wire and Floor No.2 Wire (Right Kick Panel)                              |
| EO2  |             |   |
| FE3  | 66          | Instrument Panel No.2 Wire and Instrument Panel Wire (Instrument Panel Center)            |
| HE1  | 66          | Front Door RH Wire and Instrument Panel Wire (Right Kick Panel)                           |
| HE2  |             |   |
| IE2  | 66          | Front Door LH Wire and Instrument Panel Wire (Left Kick Panel)                            |
| IM1  | 67          | Front Door LH Wire and Front Door LH No.2 Wire (Inside of the Front Door LH)              |
| IM2  |             |   |
| JO1  | 67          | Rear Door No.1 Wire and Floor No.2 Wire (Right Center Pillar)                             |
| KN1  | 67          | Rear Door No.2 Wire and Floor Wire (Left Center Pillar)                                   |
| SN1  | 67          | Luggage Room Wire and Floor Wire (Luggage Room Left)                                      |



**: Ground Points**

| Code | See Page    | Ground Points Location          |
|------|-------------|---------------------------------|
| C6   | 65 (2AZ-FE) | Cylinder Block                  |
| C7   | 64 (2GR-FE) | Left Side of the Cylinder Block |
| E1   | 66          | Instrument Panel Left           |
| E2   | 66          | Instrument Panel Brace LH       |
| F1   | 66          | Instrument Panel Left           |
| N1   | 67          | Left Rear Quarter Panel         |
| O1   | 67          | Right Rear Quarter Panel        |
| S1   | 67          | Lower Back Panel Center         |



# Wireless Door Lock Control without Smart Key System

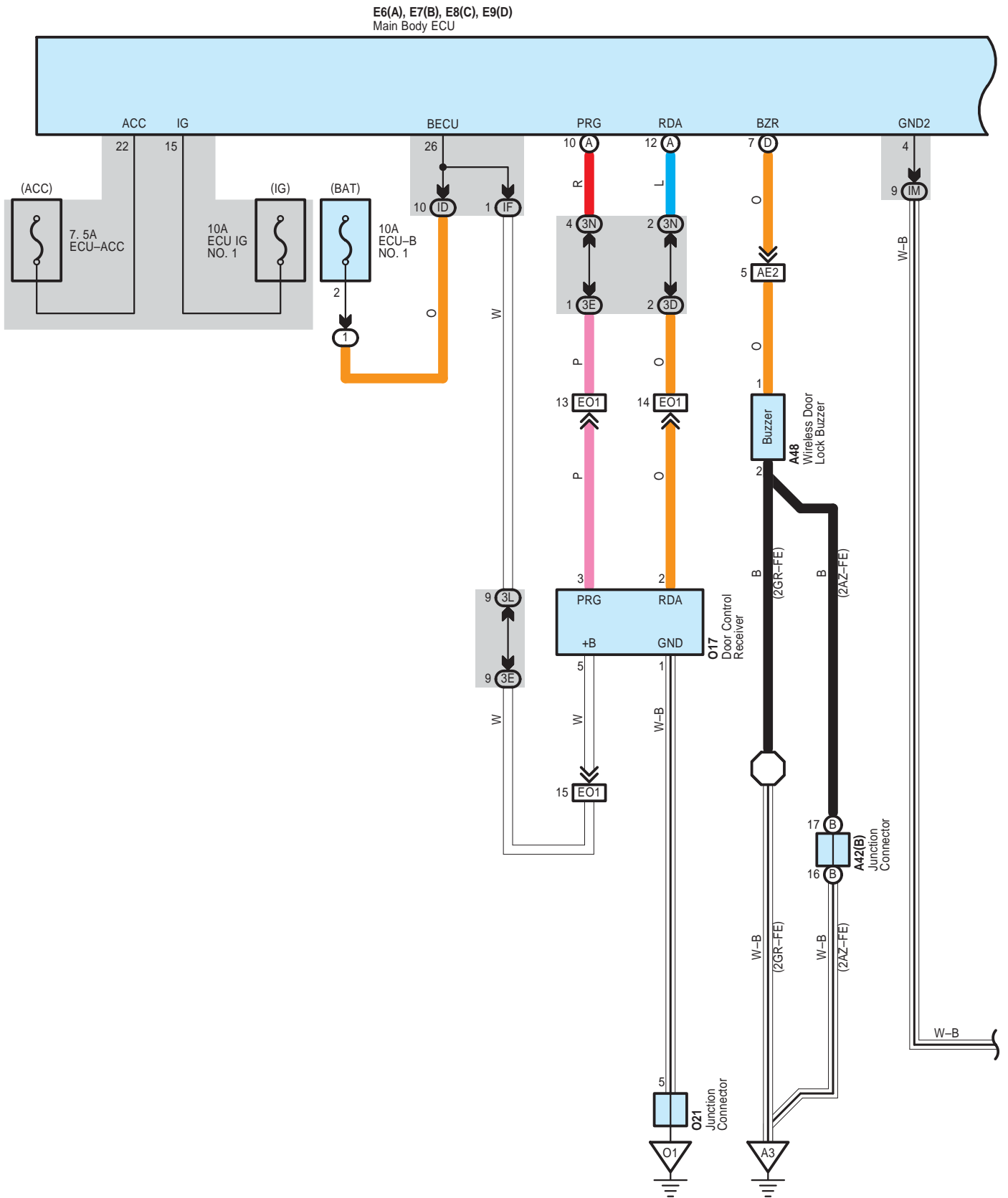

E6(A), E7(B), E8(C), E9(D)  
Main Body ECU

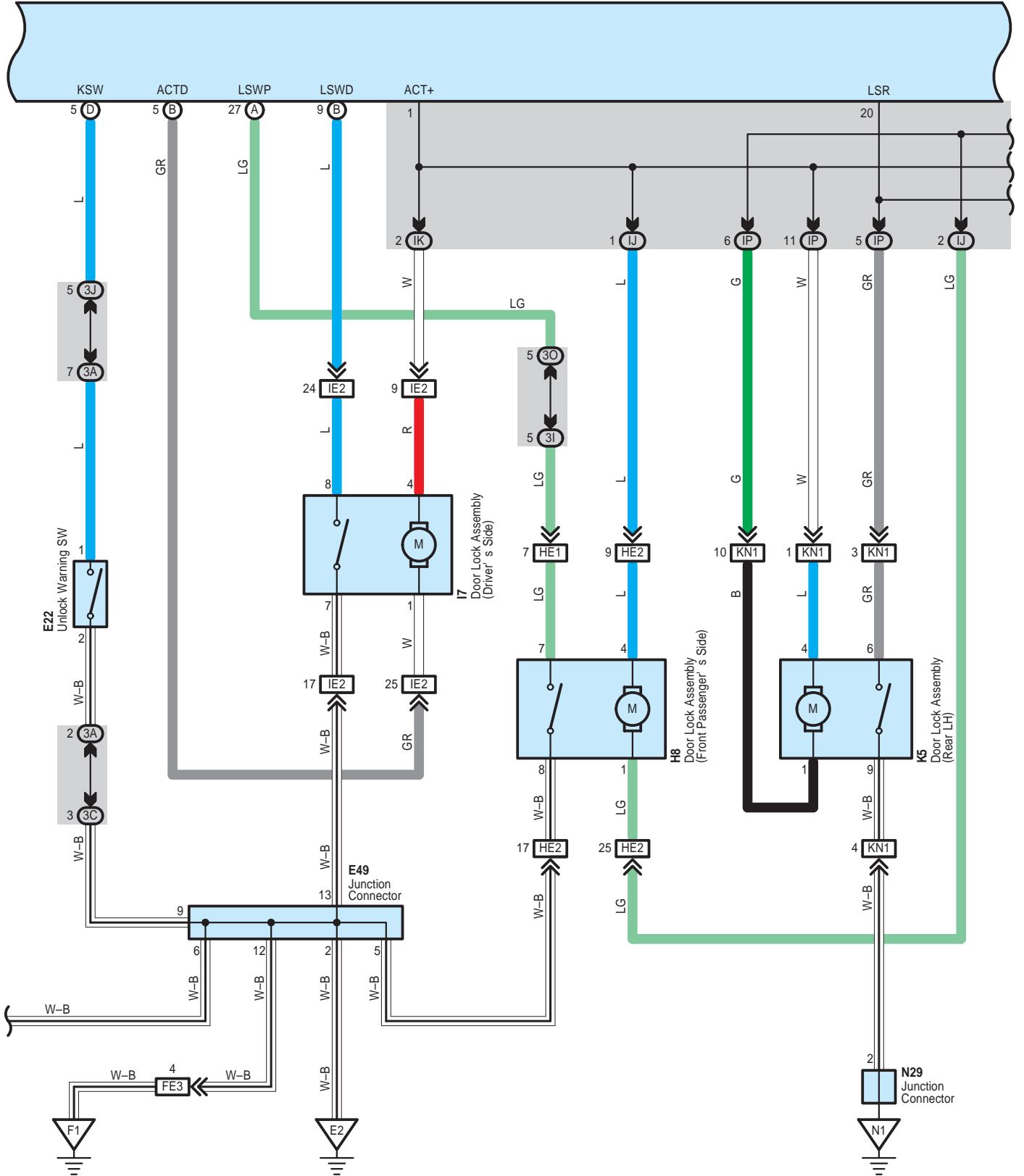

# Wireless Door Lock Control without Smart Key System

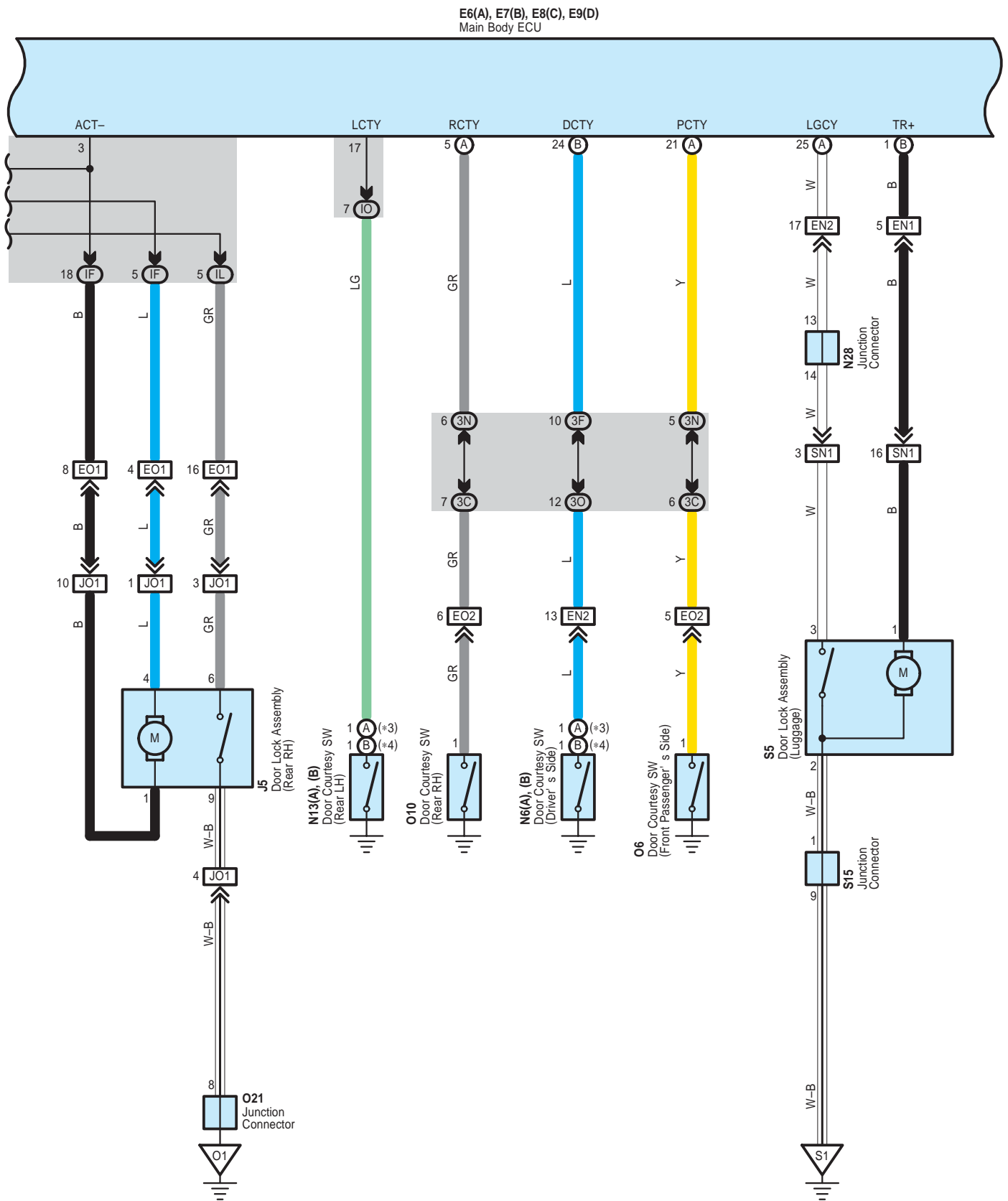

- \* 1 : w/ Sliding Roof
- \* 2 : w/o Sliding Roof
- \* 3 : TMC Made
- \* 4 : TMMK Made

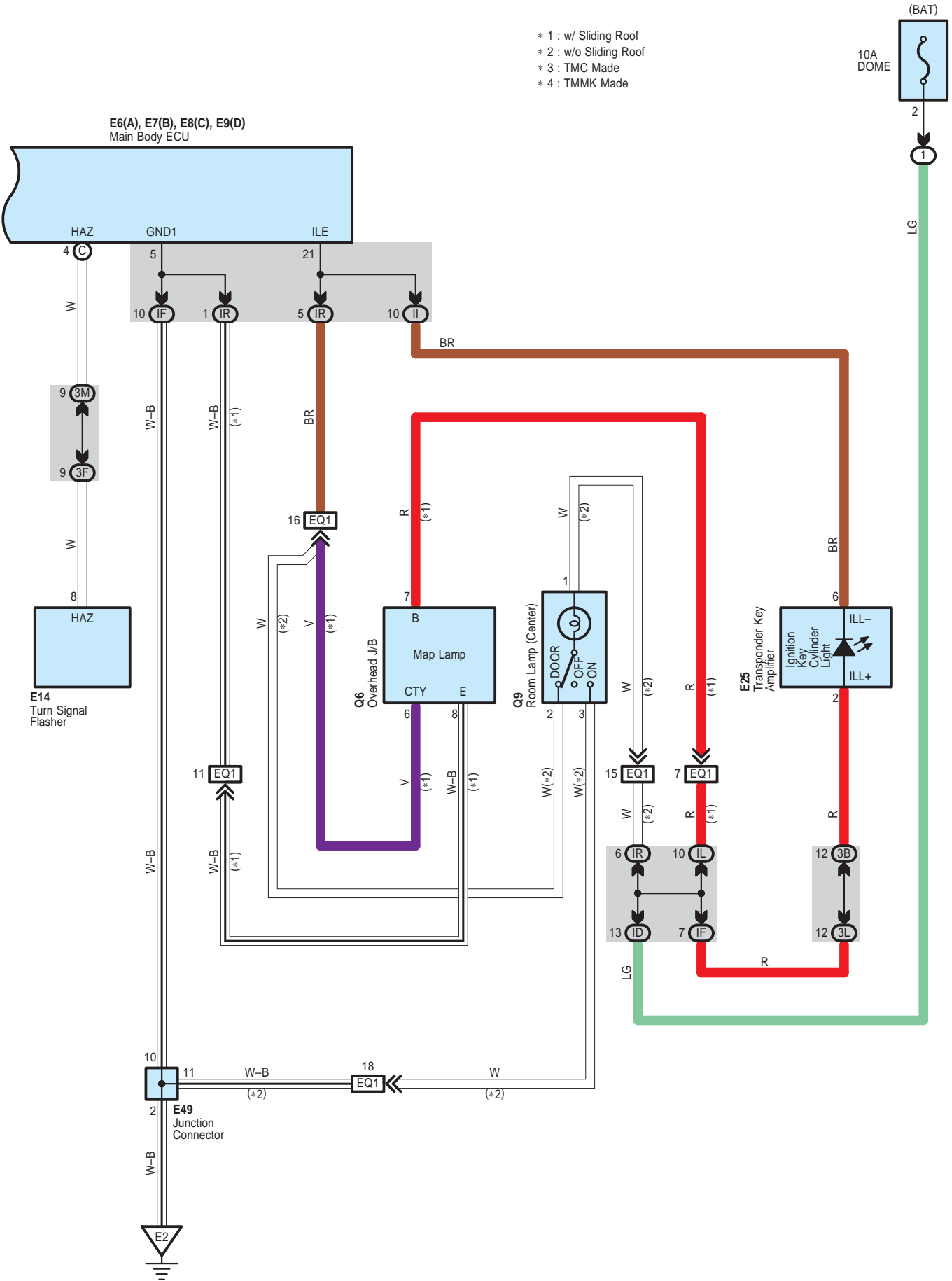

# Wireless Door Lock Control without Smart Key System

## System Outline

Door lock control (Lock and unlock) and panic control (Theft alarm and flash) is performed by remote control, without the ignition key inserted in the door key cylinder, using low-power electrical waves emitted by a transmitter.

### 1. Wireless Door Lock or Unlock Normal Operation

With the ignition key not inserted into the ignition key cylinder (Unlock warning SW off) and all the doors completely closed, when the lock or unlock button (Transmitter) is pushed, the door control receiver receives the electrical waves from the transmitter, and sends a signal to the main body ECU, causing it to operate.

As a result, the main body ECU judges whether the door is locked or unlocked based on the signal from the door lock motor and door unlock detection SW, and sends a signal to switch the condition from lock to unlock or vice versa, causing the door lock motor to operate.

### 2. Visual Confirmation of Lock or Unlock

If all doors indicate that they are locked after the lock command, turn signal light will flash once. If any door indicates that it is open after the unlock command, turn signal light will flash twice.

### 3. Buzzer Sound Function

If all doors indicate that they are locked after the lock command, the keyless buzzer goes on once. If any door indicates that it is open after the unlock command, the keyless buzzer goes on twice.

### 4. Illuminated Entry Function

When the main body ECU detects the unlock state after the unlock operation has been made, it turns on the lights, such as the ignition key cylinder light and interior light for approx. 15 sec. If all the doors are locked during this operation, lighting is cancelled and the lights immediately fade out.

### 5. Wireless Door Unlock Operation

Pushing the unlock button (Transmitter) once, driver's door is unlocked. Furthermore, pushing the button again within 3 seconds, the other doors are unlocked.

### 6. Automatic Lock Operation

With the ignition key not inserted into the ignition key cylinder (Unlock warning SW off) and all the doors completely closed, after pushing the button (Transmitter) to unlock all the doors, if a door is not opened within 30 seconds, all the doors will be automatically relocked.

### 7. Wireless Control Stop Function

If a door is open (Door courtesy SW on), a signal is input from the door courtesy SW to the main body ECU stopping wireless door lock or unlock.

If the ignition key is in the ignition key cylinder (Unlock warning SW on), the unlock warning SW inputs a signal to the main body ECU stopping wireless door lock or unlock.

### 8. Repeat Function

If the door lock or unlock condition does not change after wireless door lock or unlock operation, 2 seconds later, the main body ECU sends current again to the door lock motor.

### 9. Remote Panic Operation

Panic will function when doors are locked or unlocked, open or closed. When the panic button (Transmitter) is pushed once, theft alarm and horn sounds and turn signal light, headlights and taillight flash. Then, the panic or the unlock button (Transmitter) is pushed once more, sounding and flashing will stop. Panic will not function when ignition key is in ignition key cylinder.

## ○ : Parts Location

| Code | See Page | Code        | See Page | Code | See Page |     |    |
|------|----------|-------------|----------|------|----------|-----|----|
| A42  | B        | 59          | E49      | 57   | N29      | 60  |    |
| A48  |          | 49 (2GR-FE) | H8       | 61   | O6       | 60  |    |
|      |          | 53 (2AZ-FE) | I7       | 61   | O10      | 60  |    |
| E6   | A        | 56          | J5       | 61   | O17      | 60  |    |
| E7   | B        | 56          | K5       | 61   | O21      | 60  |    |
| E8   | C        | 56          | N6       | A    | 60       | Q6  | 61 |
| E9   | D        | 56          |          | B    | 60       | Q9  | 61 |
| E14  |          | 56          | N13      | A    | 60       | S5  | 61 |
| E22  |          | 56          |          | B    | 60       | S15 | 61 |
| E25  |          | 56          | N28      | 60   |          |     |    |

 : Relay Blocks

| Code | See Page | Relay Blocks (Relay Block Location)       |
|------|----------|---|
| 1    | 22       | Engine Room R/B (Engine Compartment Left) |

 : Junction Block and Wire Harness Connector

| Code | See Page | Junction Block and Wire Harness (Connector Location)              |
|------|----------|---|
| 3A   | 36       | Instrument Panel Wire and J/B No.3 (Behind the Combination Meter) |
| 3B   |          |   |
| 3C   |          |   |
| 3D   |          |   |
| 3E   |          |   |
| 3F   |          |   |
| 3I   |          |   |
| 3J   |          |   |
| 3L   |          |   |
| 3M   |          |   |
| 3N   |          |   |
| 3O   |          |   |
| ID   | 30       | Engine Room Main Wire and Instrument Panel J/B (Cowl Side Left)   |
| IF   | 30       | Instrument Panel Wire and Instrument Panel J/B (Cowl Side Left)   |
| II   | 31       |   |
| IJ   | 30       |   |
| IK   |          |   |
| IL   |          |   |
| IM   |          |   |
| IO   | 30       | Floor Wire and Instrument Panel J/B (Cowl Side Left)              |
| IP   |          |   |
| IR   | 30       | Instrument Panel Wire and Instrument Panel J/B (Cowl Side Left)   |

 : Connector Joining Wire Harness and Wire Harness

| Code | See Page | Joining Wire Harness and Wire Harness (Connector Location)                               |
|------|----------|--|
| AE2  | 66       | Engine Room Main Wire and Instrument Panel Wire (Right Side of the Instrument Panel J/B) |
| EN1  | 66       | Instrument Panel Wire and Floor Wire (Left Kick Panel)                                   |
| EN2  |          |  |
| EO1  | 66       | Instrument Panel Wire and Floor No.2 Wire (Right Kick Panel)                             |
| EO2  |          |  |
| EQ1  | 66       | Instrument Panel Wire and Roof Wire (Lower Part of Front Pillar LH)                      |
| FE3  | 66       | Instrument Panel No.2 Wire and Instrument Panel Wire (Instrument Panel Center)           |
| HE1  | 66       | Front Door RH Wire and Instrument Panel Wire (Right Kick Panel)                          |
| HE2  |          |  |
| IE2  | 66       | Front Door LH Wire and Instrument Panel Wire (Left Kick Panel)                           |
| JO1  | 67       | Rear Door No.1 Wire and Floor No.2 Wire (Right Center Pillar)                            |
| KN1  | 67       | Rear Door No.2 Wire and Floor Wire (Left Center Pillar)                                  |
| SN1  | 67       | Luggage Room Wire and Floor Wire (Luggage Room Left)                                     |

 : Ground Points

| Code | See Page | Ground Points Location    |
|------|----------|---------------------------|
| A3   | 66       | Left Cowl Side Panel      |
| E2   | 66       | Instrument Panel Brace LH |
| F1   | 66       | Instrument Panel Left     |
| N1   | 67       | Left Rear Quarter Panel   |
| O1   | 67       | Right Rear Quarter Panel  |
| S1   | 67       | Lower Back Panel Center   |

# Theft Deterrent

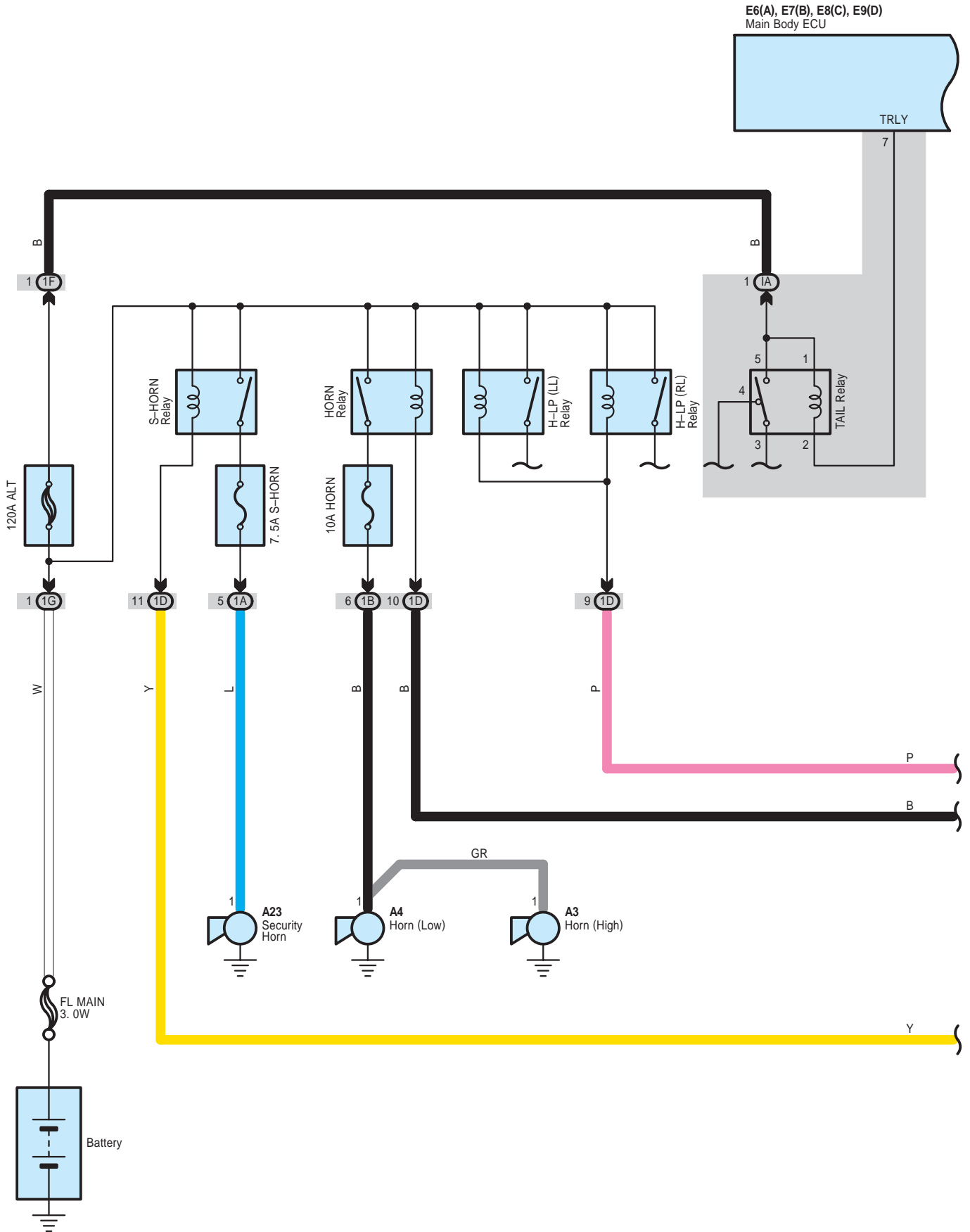

E6(A), E7(B), E8(C), E9(D)  
Main Body ECU

\* 1 : w/ Smart Key System  
\* 2 : w/o Smart Key System

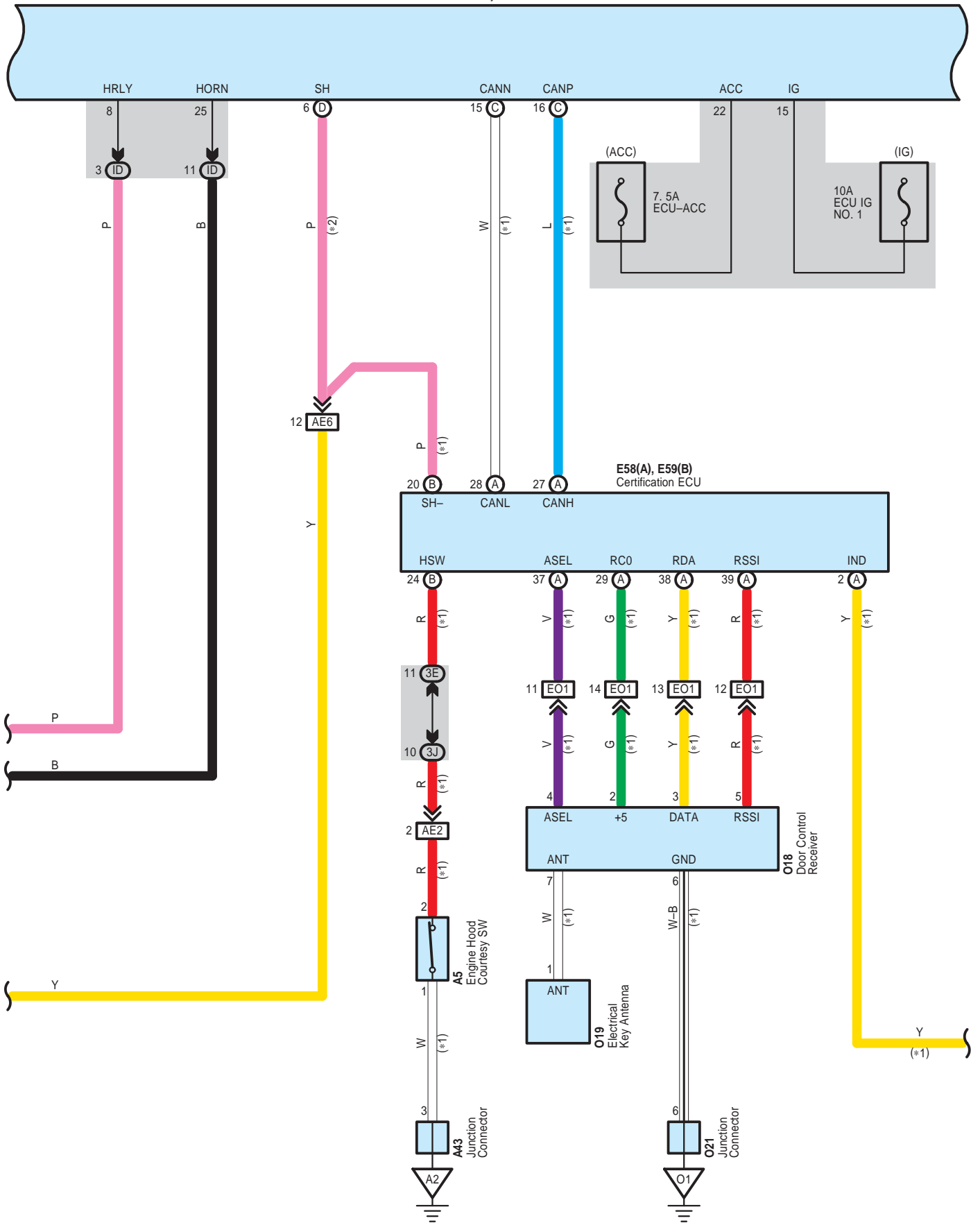



# Theft Deterrent

E6(A), E7(B), E8(C), E9(D)  
Main Body ECU

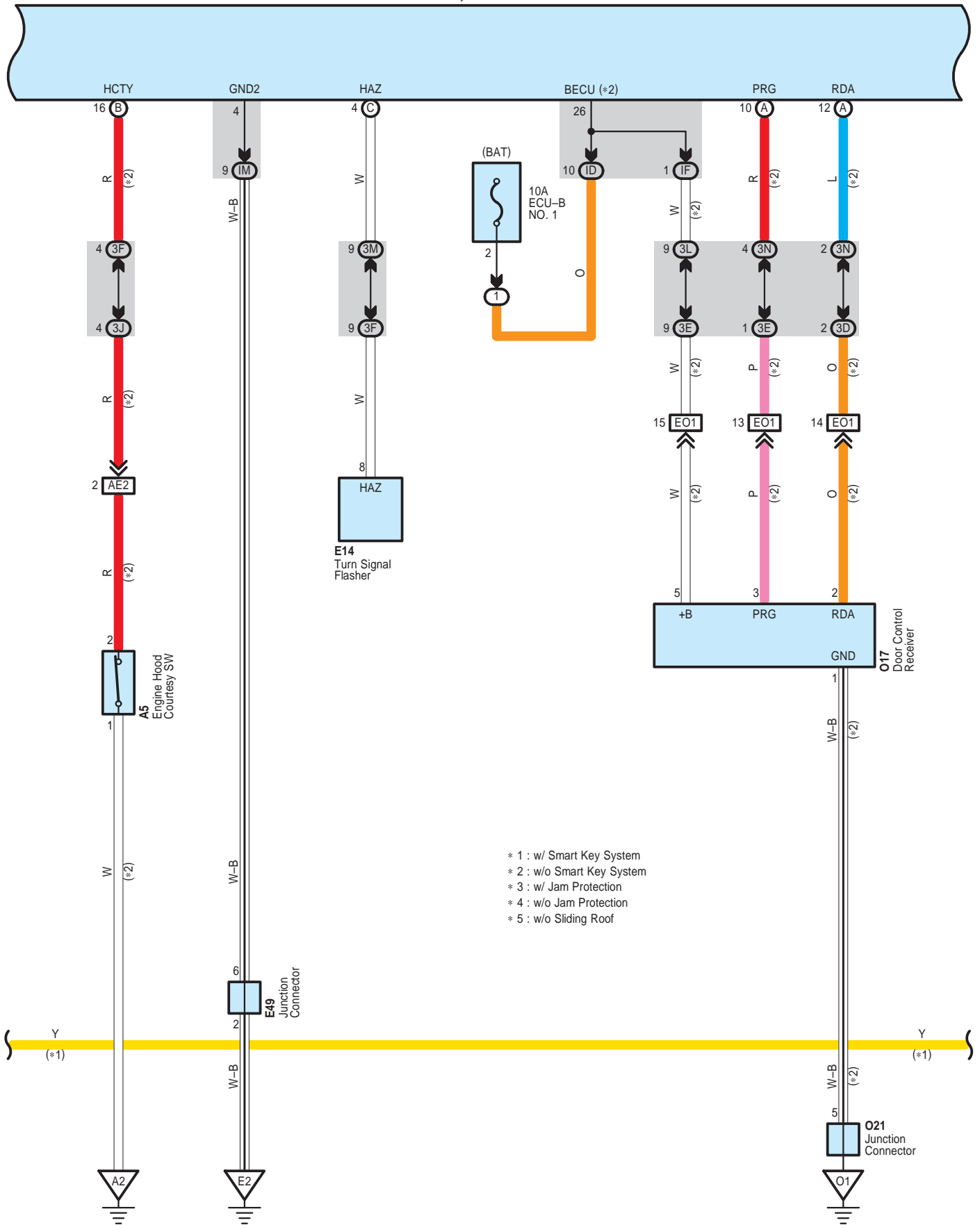

E6(A), E7(B), E8(C), E9(D)  
Main Body ECU

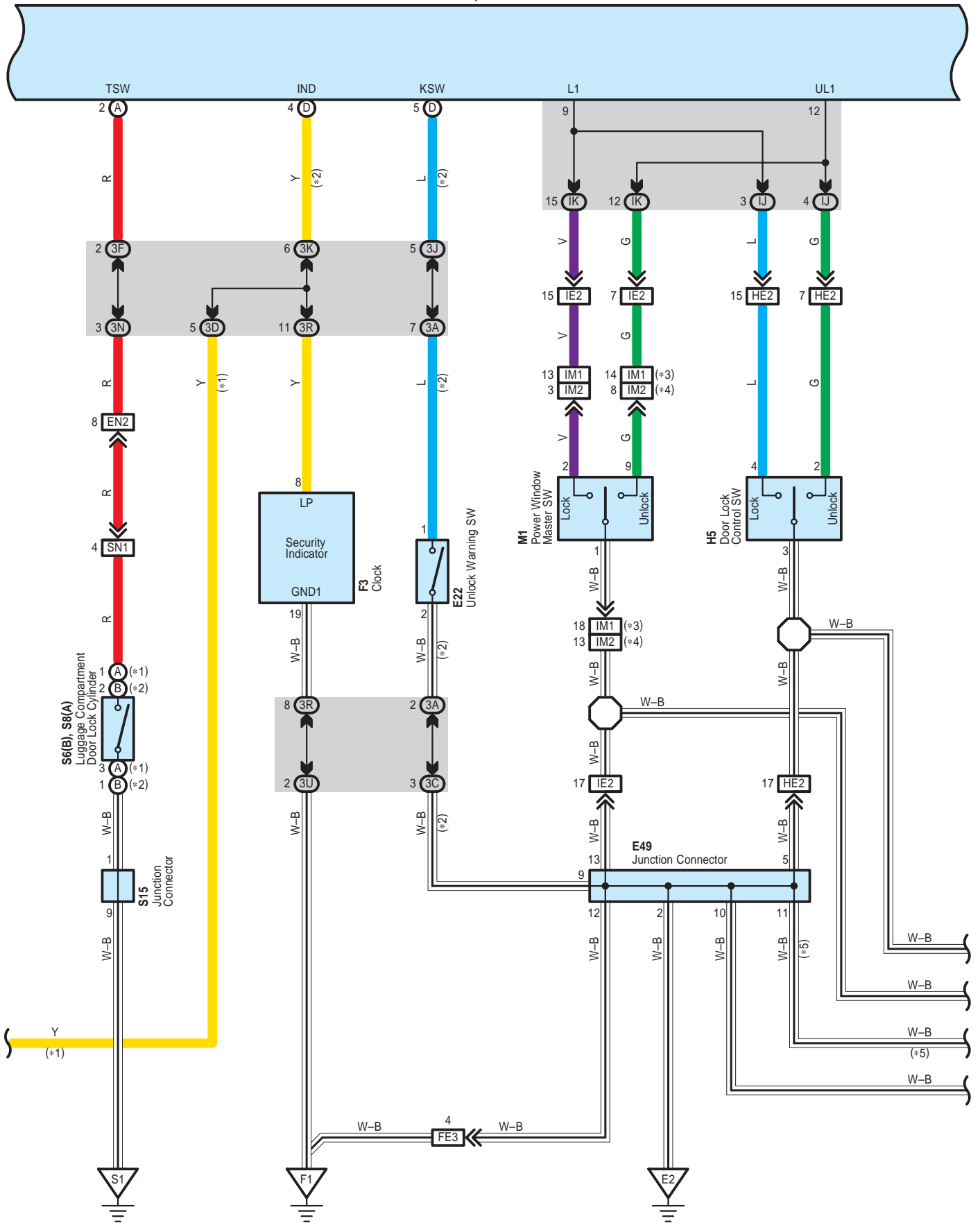

# Theft Deterrent

E6(A), E7(B), E8(C), E9(D)  
Main Body ECU

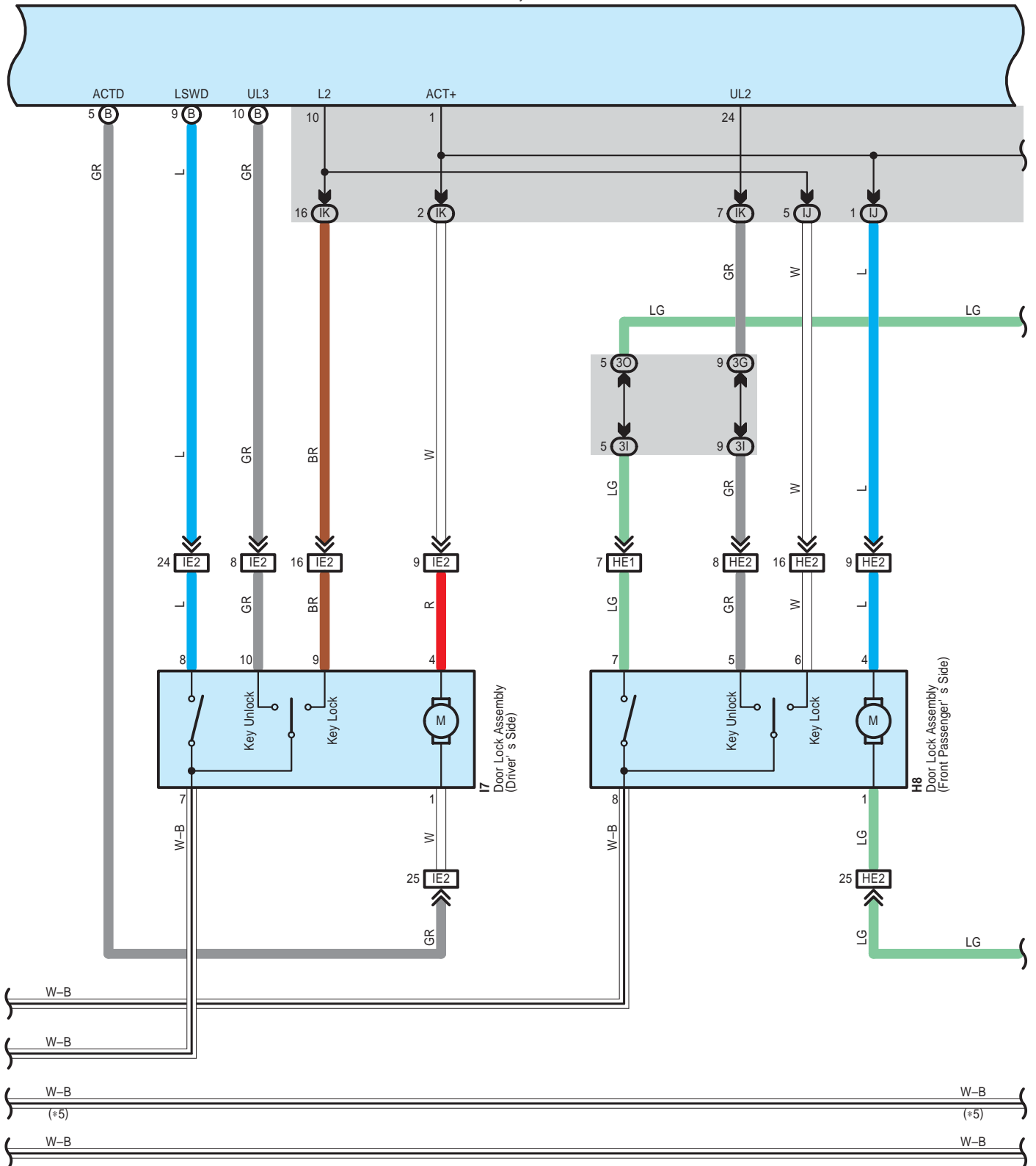

E6(A), E7(B), E8(C), E9(D)  
Main Body ECU

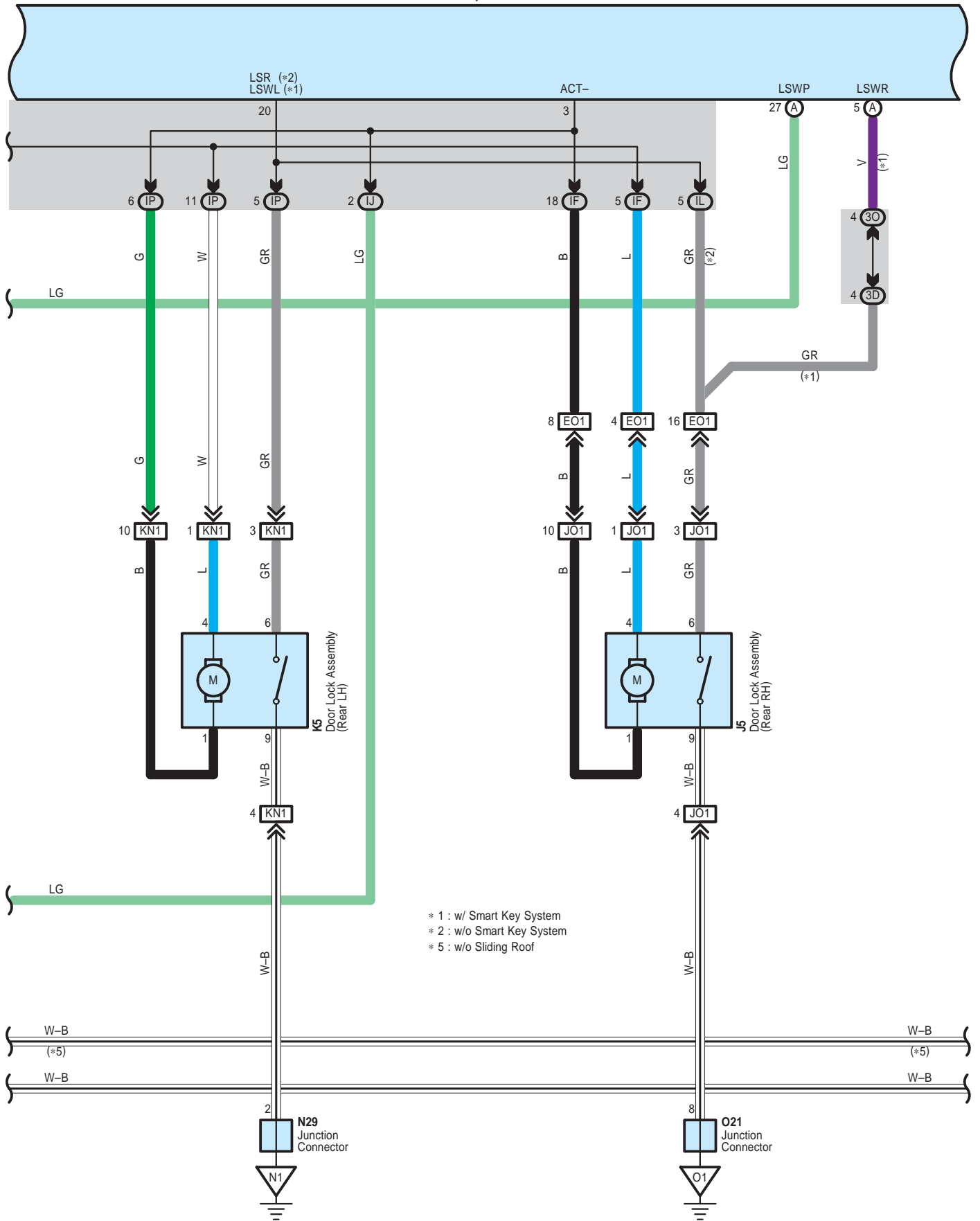

# Theft Deterrent

E6(A), E7(B), E8(C), E9(D)  
Main Body ECU

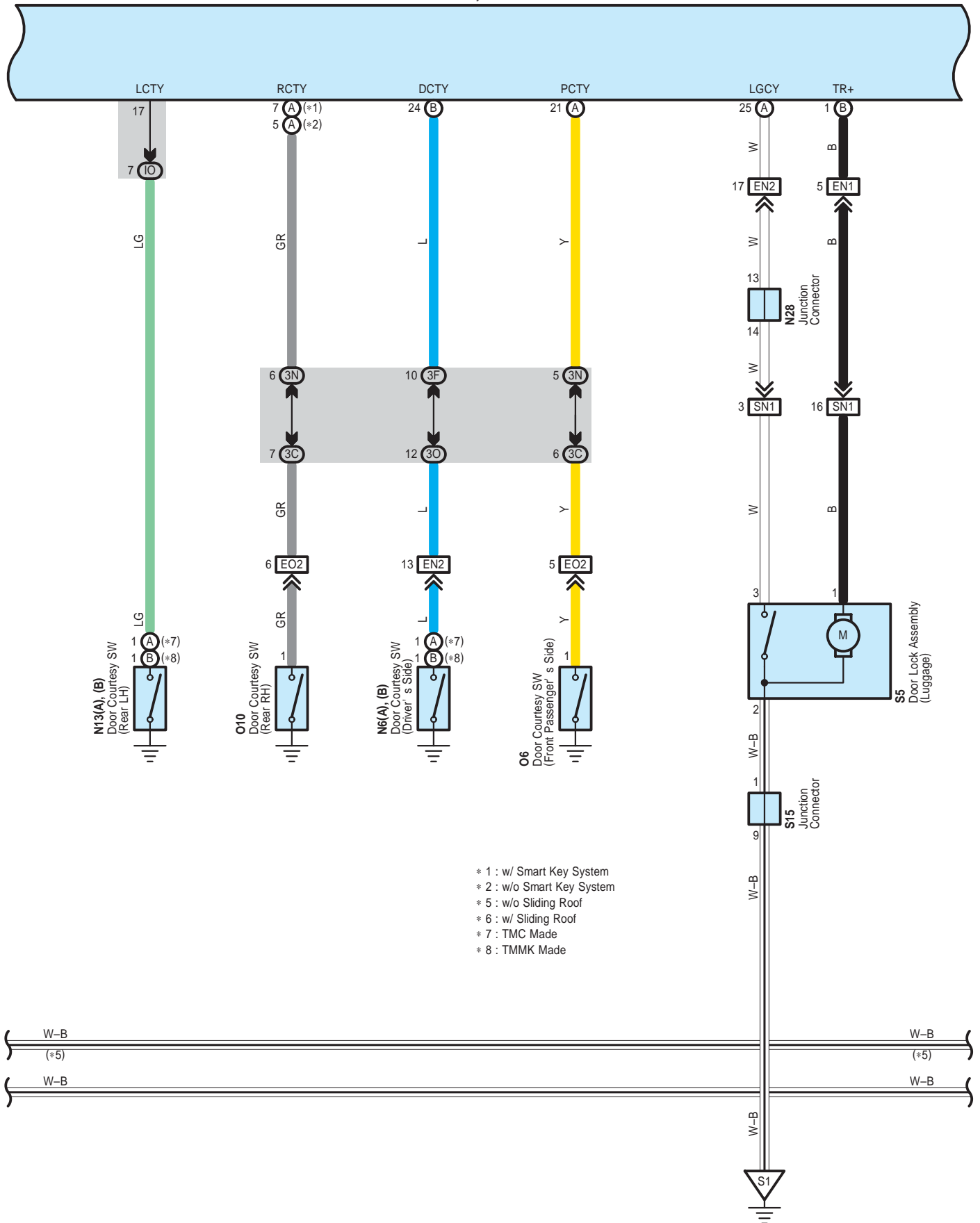

E6(A), E7(B), E8(C), E9(D)  
Main Body ECU

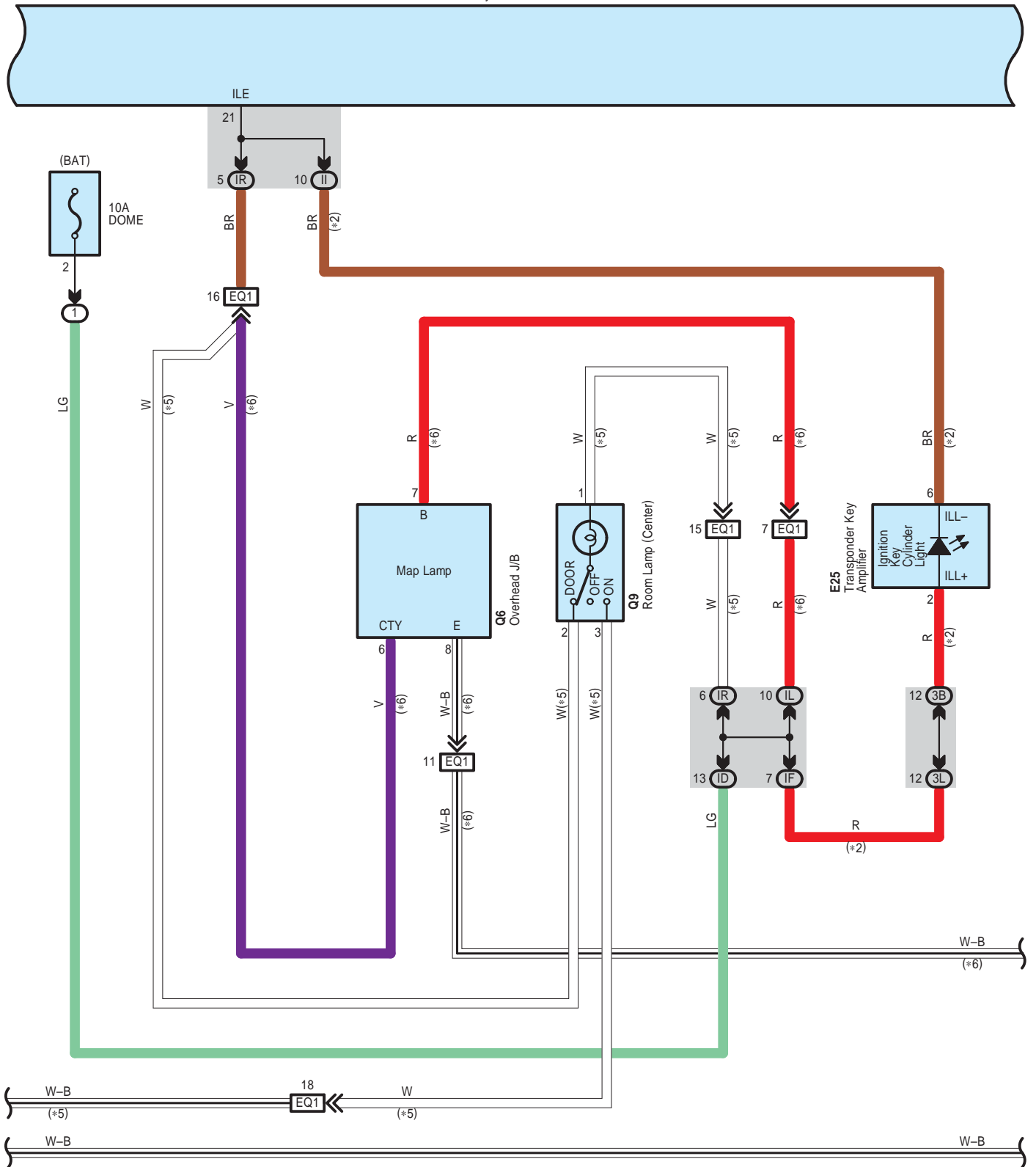

# Theft Deterrent

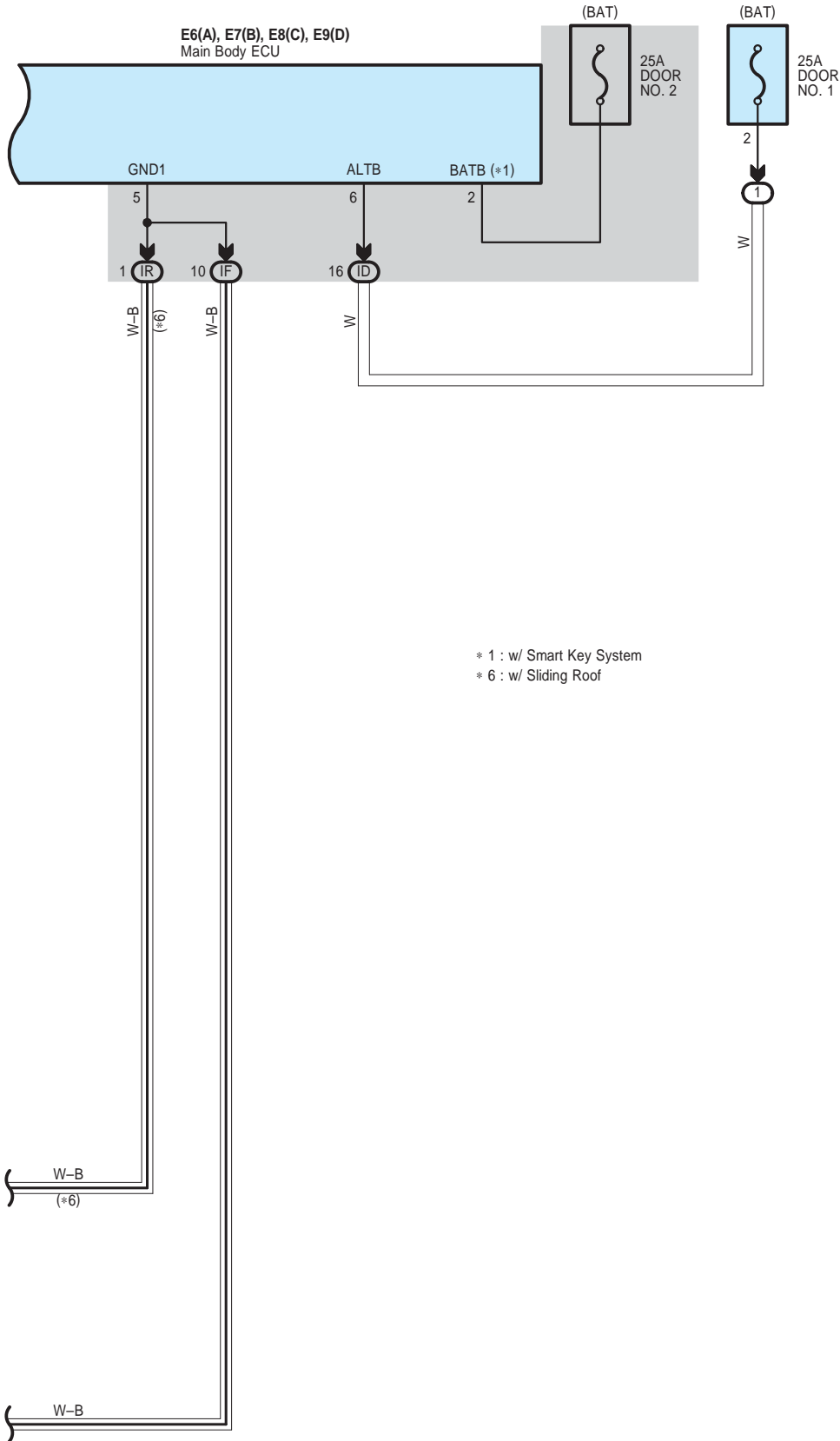

○ : Parts Location

| Code |   | See Page    | Code |   | See Page | Code |   | See Page |
|------|---|-------------|------|---|----------|------|---|----------|
| A3   |   | 48 (2GR-FE) | E25  |   | 56       | N28  |   | 60       |
|      |   | 52 (2AZ-FE) | E49  |   | 57       | N29  |   | 60       |
| A4   |   | 48 (2GR-FE) | E58  | A | 57       | O6   |   | 60       |
|      |   | 52 (2AZ-FE) | E59  | B | 57       | O10  |   | 60       |
| A5   |   | 48 (2GR-FE) | F3   |   | 58       | O17  |   | 60       |
|      |   | 52 (2AZ-FE) | H5   |   | 61       | O18  |   | 60       |
| A23  |   | 48 (2GR-FE) | H8   |   | 61       | O19  |   | 60       |
|      |   | 52 (2AZ-FE) | I7   |   | 61       | O21  |   | 60       |
| A43  |   | 49 (2GR-FE) | J5   |   | 61       | Q6   |   | 61       |
| E6   | A | 56          | K5   |   | 61       | Q9   |   | 61       |
| E7   | B | 56          | M1   |   | 61       | S5   |   | 61       |
| E8   | C | 56          | N6   | A | 60       | S6   | B | 61       |
| E9   | D | 56          |      | B | 60       | S8   | A | 61       |
| E14  |   | 56          | N13  | A | 60       | S15  |   | 61       |
| E22  |   | 56          |      | B | 60       |      |   |          |

○ : Relay Blocks

| Code | See Page | Relay Blocks (Relay Block Location)       |
|------|----------|---|
| 1    | 22       | Engine Room R/B (Engine Compartment Left) |



# Theft Deterrent

## : Junction Block and Wire Harness Connector

| Code | See Page | Junction Block and Wire Harness (Connector Location)                   |
|------|----------|--|
| 1A   | 25       | Engine Room Main Wire and Engine Room J/B (Engine Compartment Left)    |
| 1B   |          |  |
| 1D   |          |  |
| 1F   |          |  |
| 1G   | 22       |  |
| 3A   | 36       | Instrument Panel Wire and J/B No.3 (Behind the Combination Meter)      |
| 3B   |          |  |
| 3C   |          |  |
| 3D   |          |  |
| 3E   |          |  |
| 3F   |          |  |
| 3G   |          |  |
| 3I   |          |  |
| 3J   |          |  |
| 3K   |          |  |
| 3L   |          |  |
| 3M   |          |  |
| 3N   |          |  |
| 3O   |          |  |
| 3R   | 36       | Instrument Panel No.2 Wire and J/B No.3 (Behind the Combination Meter) |
| 3U   |          |  |
| IA   | 30       | Engine Room Main Wire and Instrument Panel J/B (Cowl Side Left)        |
| ID   |          |  |
| IF   | 30       | Instrument Panel Wire and Instrument Panel J/B (Cowl Side Left)        |
| II   | 31       |  |
| IJ   | 30       |  |
| IK   |          |  |
| IL   |          |  |
| IM   |          |  |
| IO   | 30       | Floor Wire and Instrument Panel J/B (Cowl Side Left)                   |
| IP   |          |  |
| IR   | 30       | Instrument Panel Wire and Instrument Panel J/B (Cowl Side Left)        |

## : Connector Joining Wire Harness and Wire Harness

| Code | See Page | Joining Wire Harness and Wire Harness (Connector Location)                               |
|------|----------|--|
| AE2  | 66       | Engine Room Main Wire and Instrument Panel Wire (Right Side of the Instrument Panel J/B) |
| AE6  | 66       | Engine Room Main Wire and Instrument Panel Wire (Instrument Panel Right)                 |
| EN1  | 66       | Instrument Panel Wire and Floor Wire (Left Kick Panel)                                   |
| EN2  |          |  |
| EO1  | 66       | Instrument Panel Wire and Floor No.2 Wire (Right Kick Panel)                             |
| EO2  |          |  |
| EQ1  | 66       | Instrument Panel Wire and Roof Wire (Lower Part of Front Pillar LH)                      |
| FE3  | 66       | Instrument Panel No.2 Wire and Instrument Panel Wire (Instrument Panel Center)           |
| HE1  | 66       | Front Door RH Wire and Instrument Panel Wire (Right Kick Panel)                          |
| HE2  |          |  |
| IE2  | 66       | Front Door LH Wire and Instrument Panel Wire (Left Kick Panel)                           |
| IM1  | 67       | Front Door LH Wire and Front Door LH No.2 Wire (Inside of the Front Door LH)             |
| IM2  |          |  |
| JO1  | 67       | Rear Door No.1 Wire and Floor No.2 Wire (Right Center Pillar)                            |
| KN1  | 67       | Rear Door No.2 Wire and Floor Wire (Left Center Pillar)                                  |
| SN1  | 67       | Luggage Room Wire and Floor Wire (Luggage Room Left)                                     |



**: Ground Points**

| Code | See Page    | Ground Points Location    |
|------|-------------|---------------------------|
| A2   | 64 (2GR-FE) | Front Left Fender         |
|      | 65 (2AZ-FE) |                           |
| E2   | 66          | Instrument Panel Brace LH |
| F1   | 66          | Instrument Panel Left     |
| N1   | 67          | Left Rear Quarter Panel   |
| O1   | 67          | Right Rear Quarter Panel  |
| S1   | 67          | Lower Back Panel Center   |

# ABS, TRAC and VSC (TMC Made)

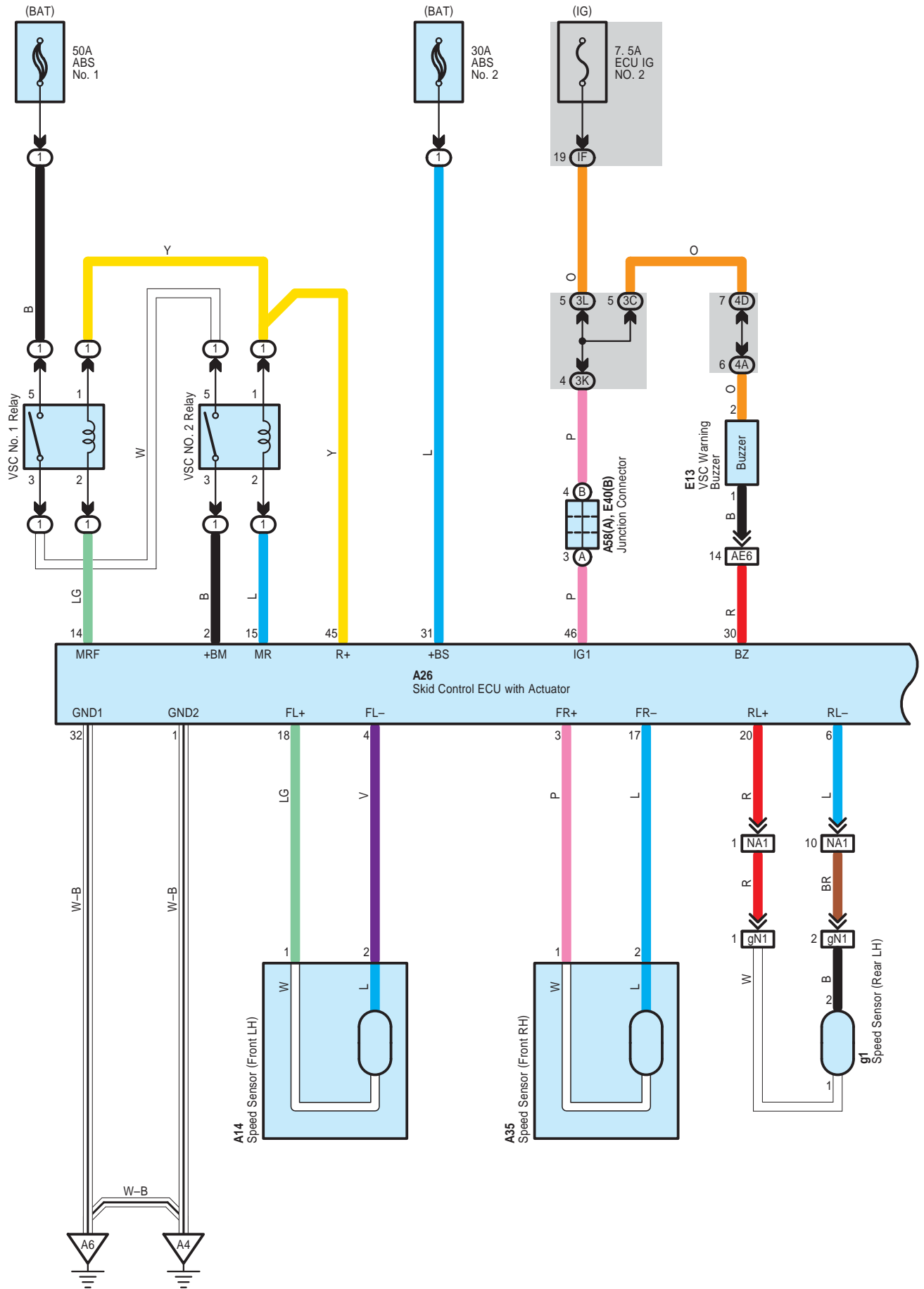

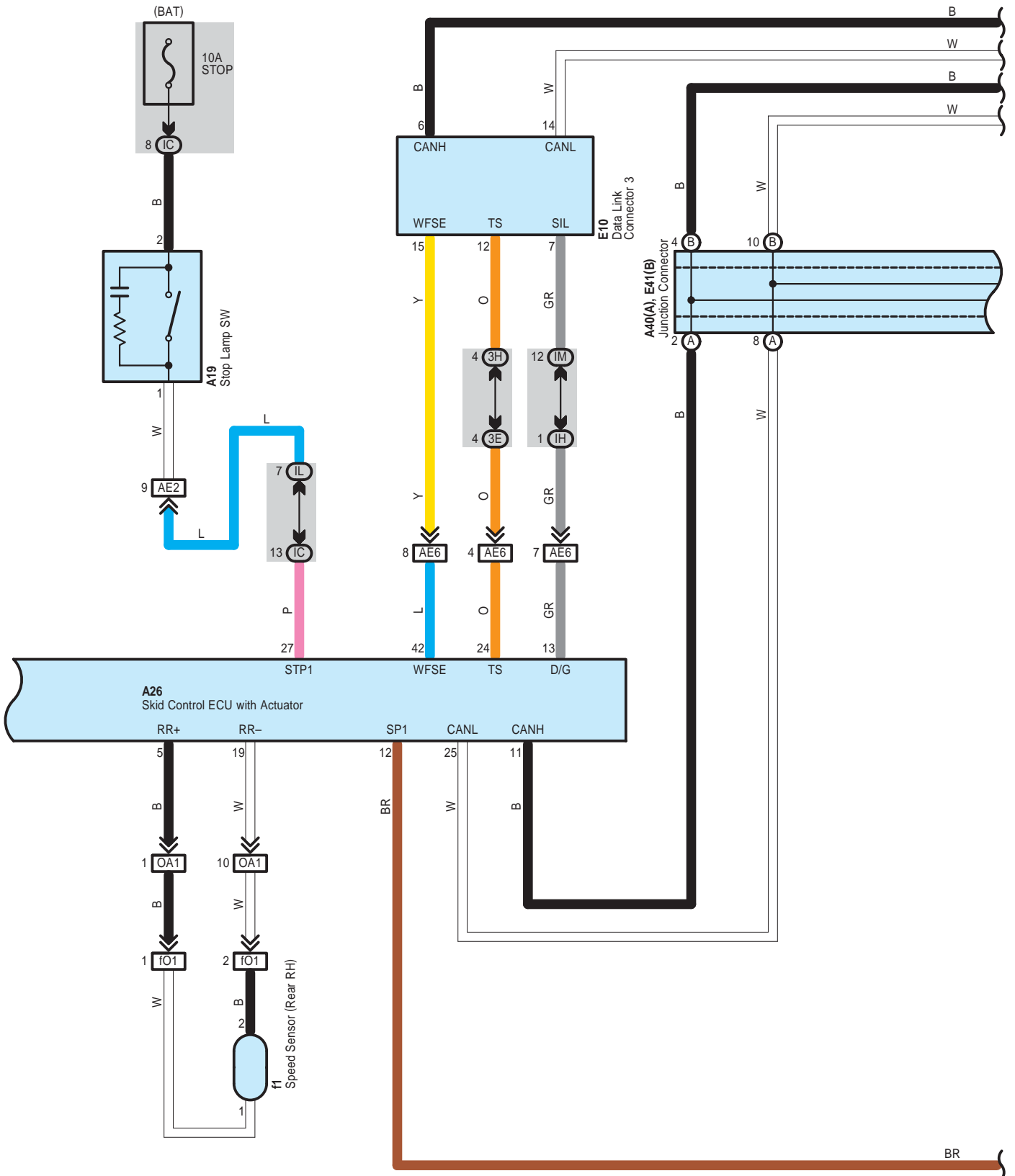

# ABS, TRAC and VSC (TMC Made)

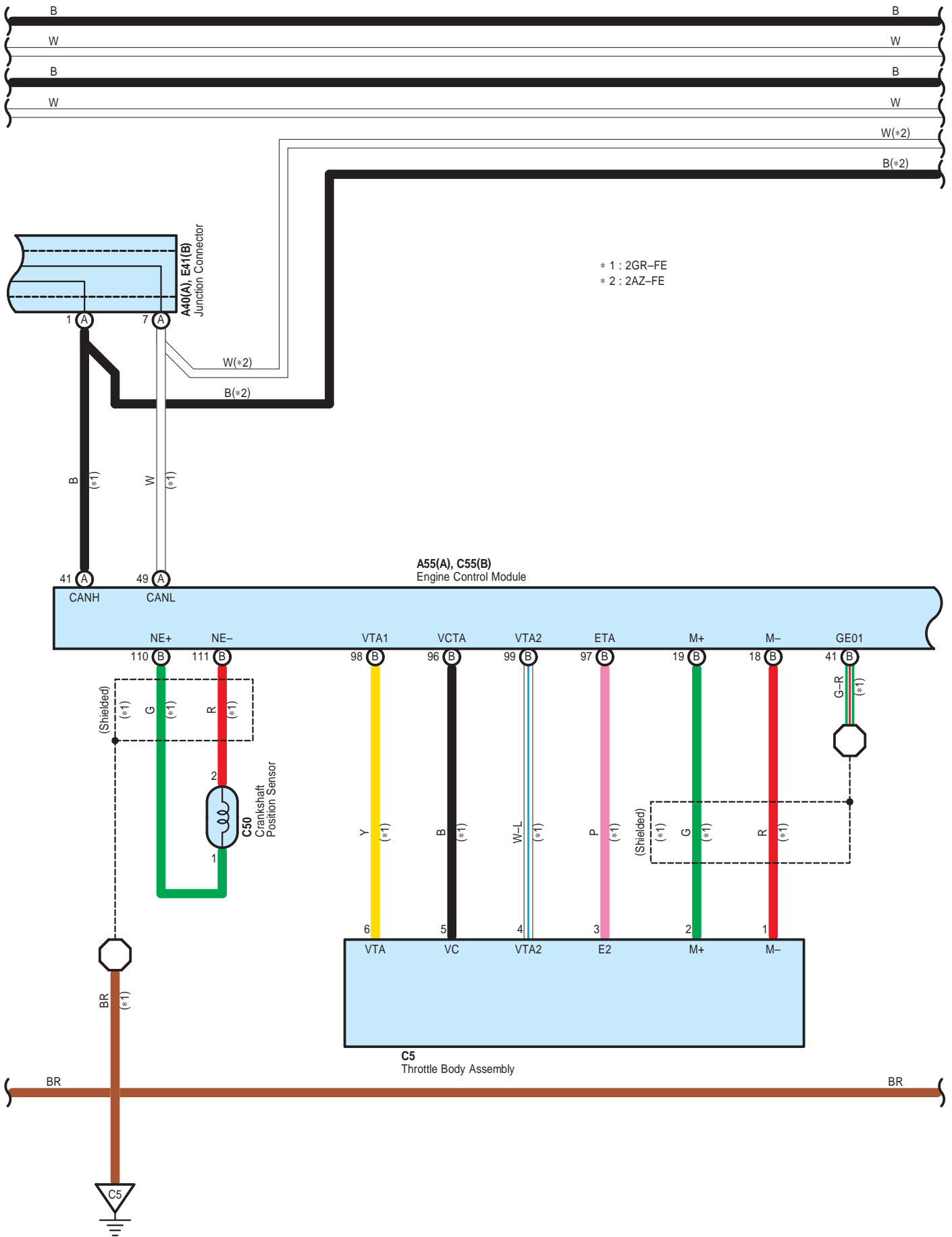

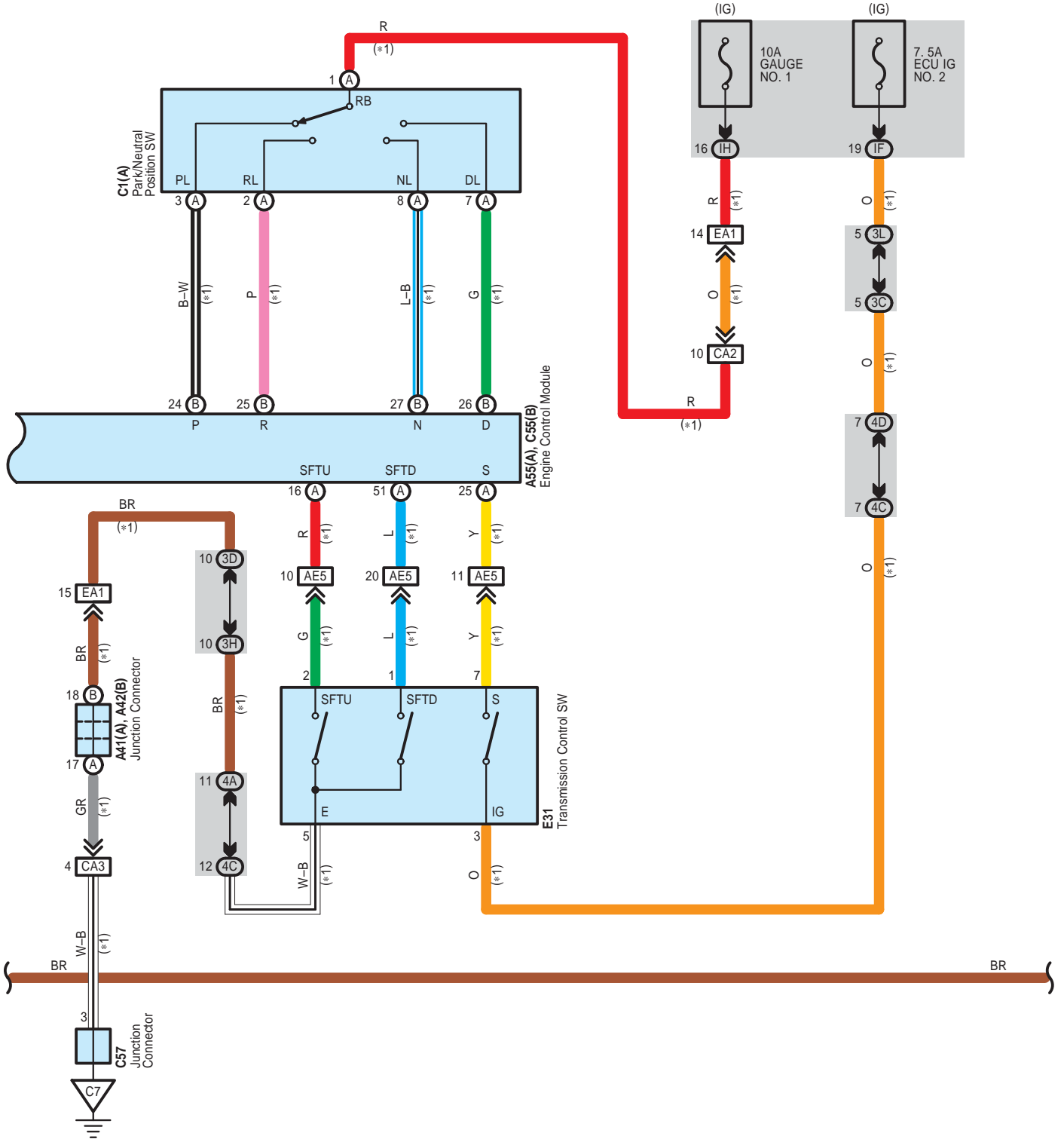
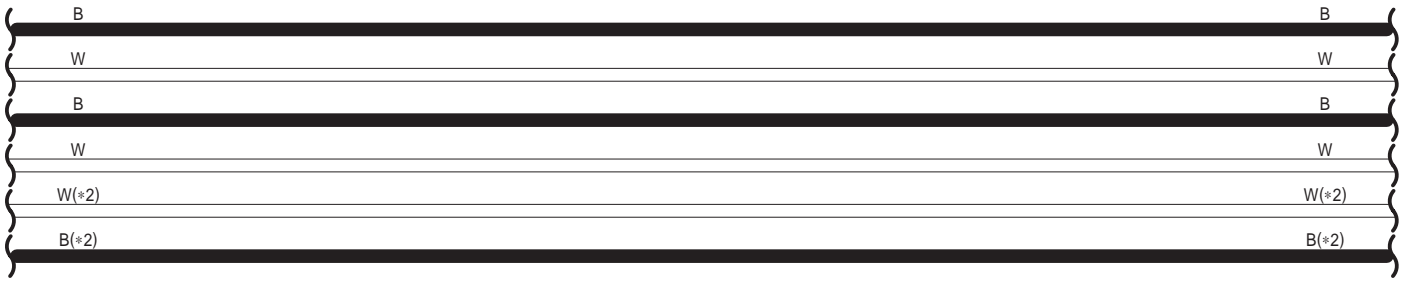

# ABS, TRAC and VSC (TMC Made)

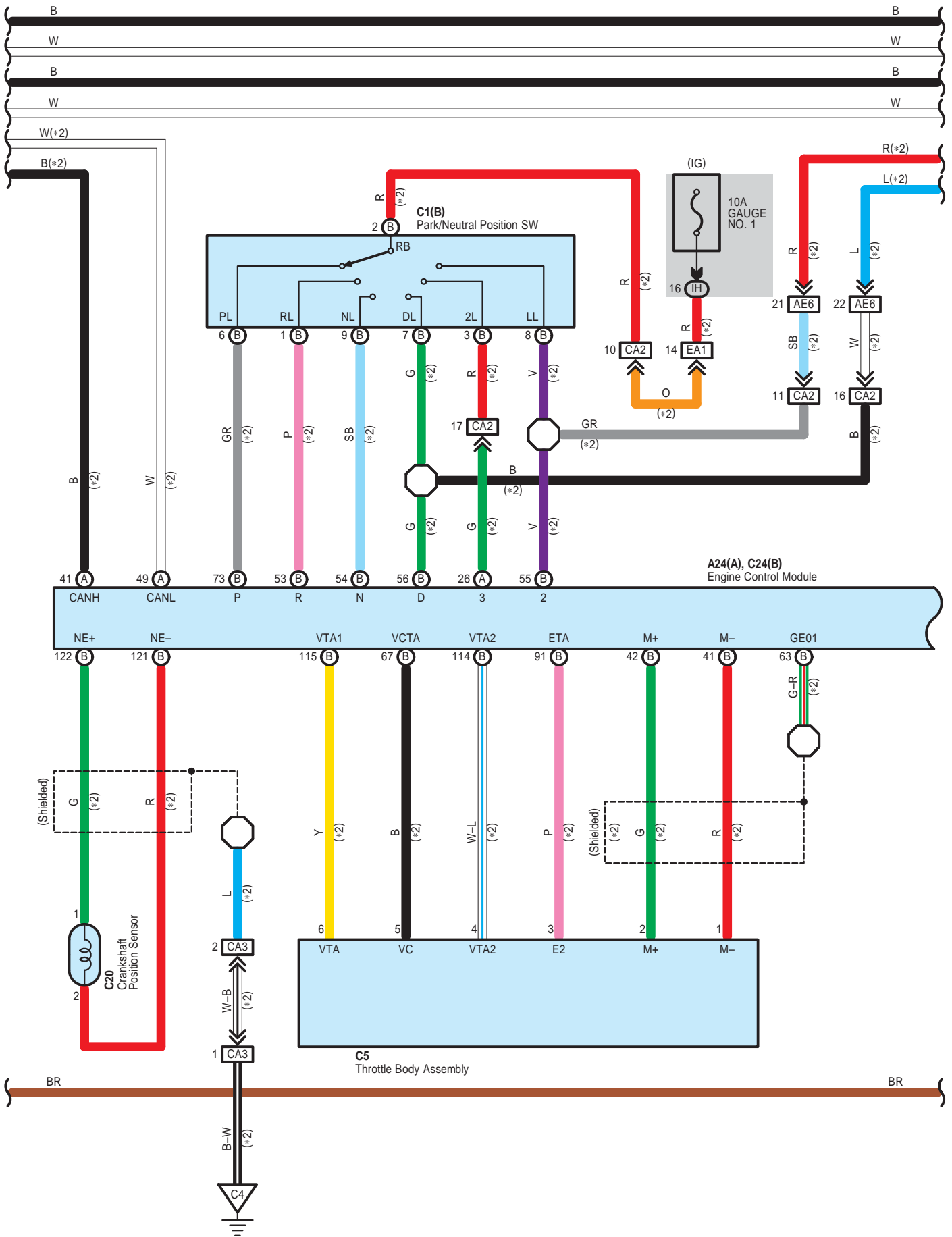

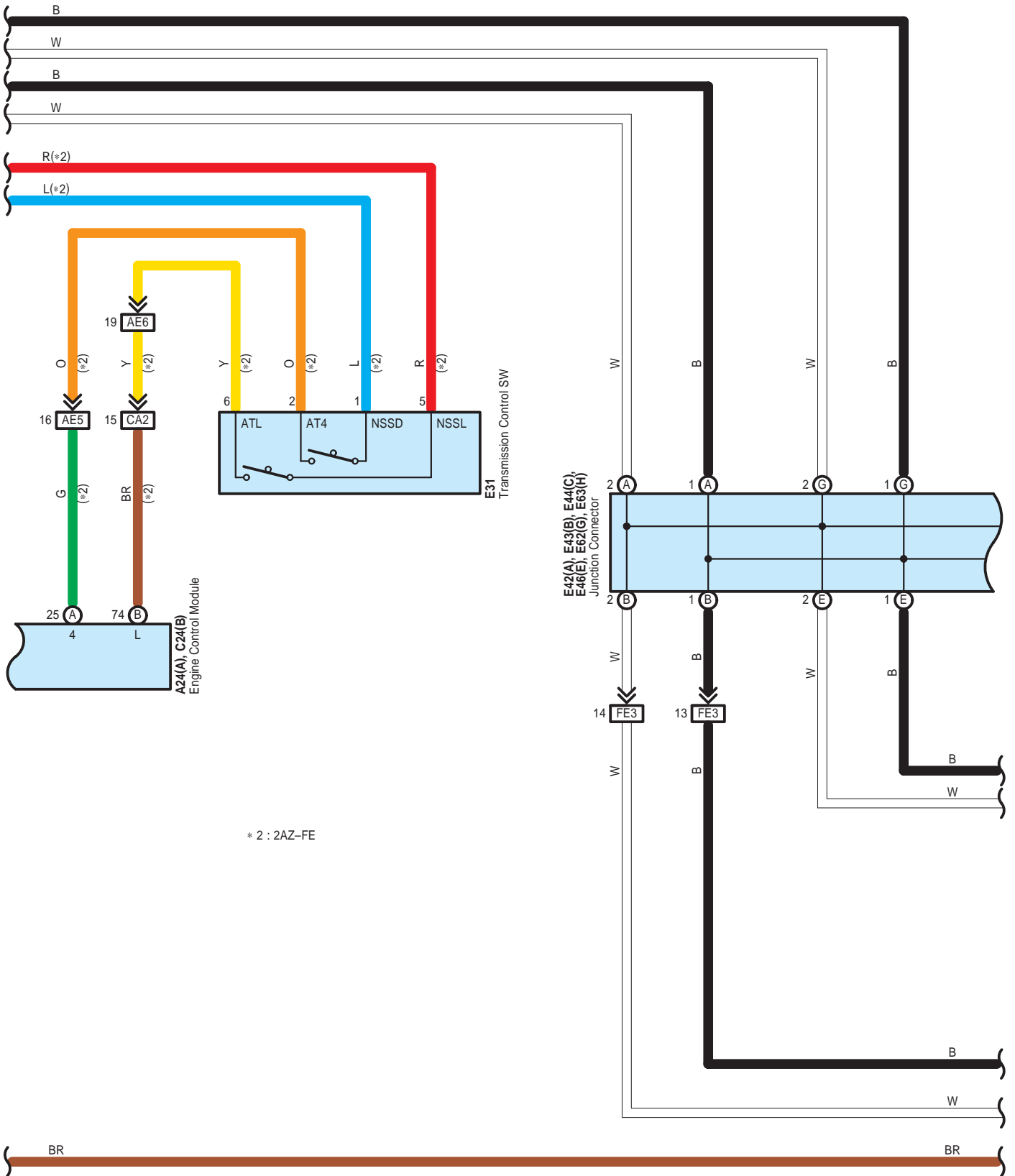



# ABS, TRAC and VSC (TMC Made)

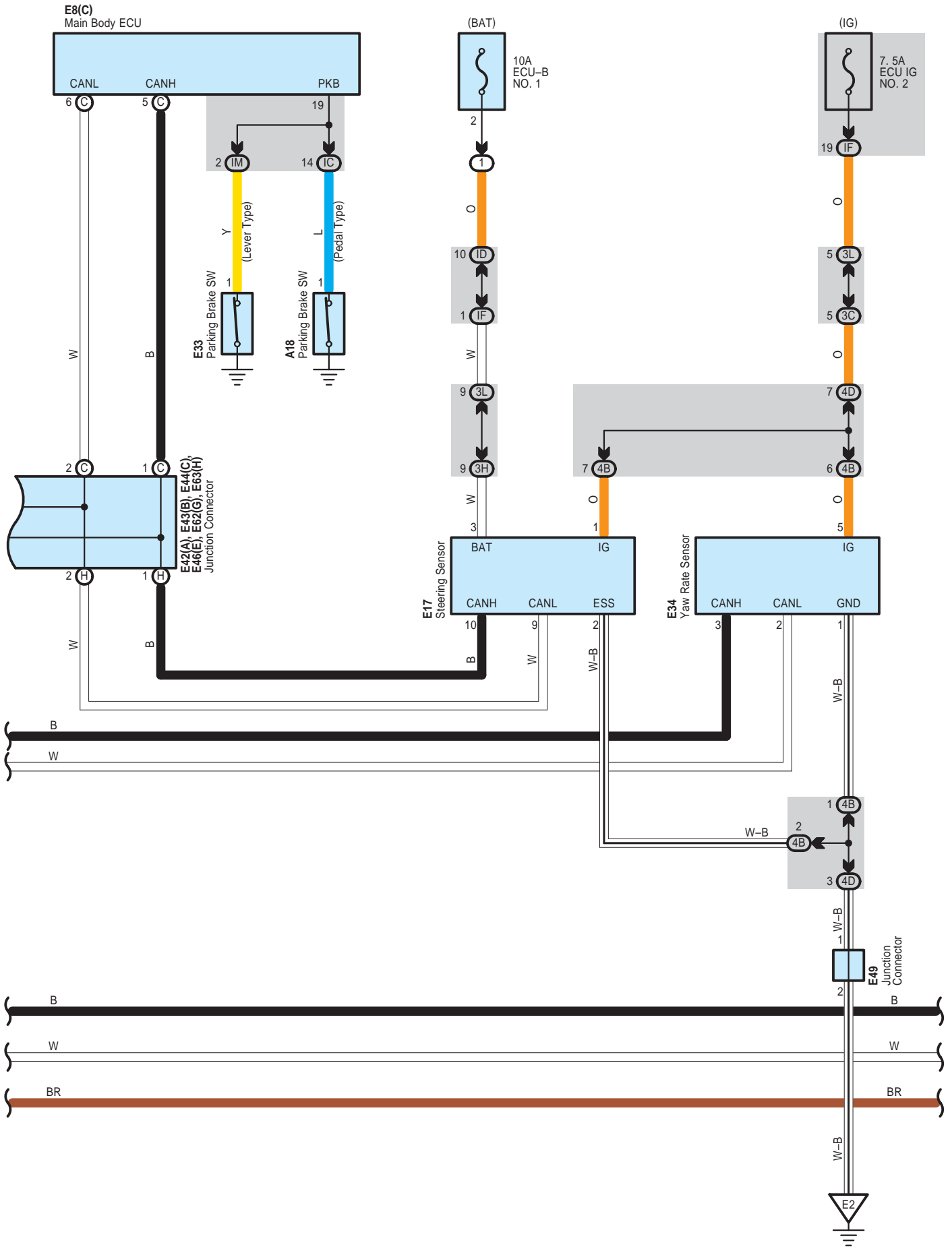

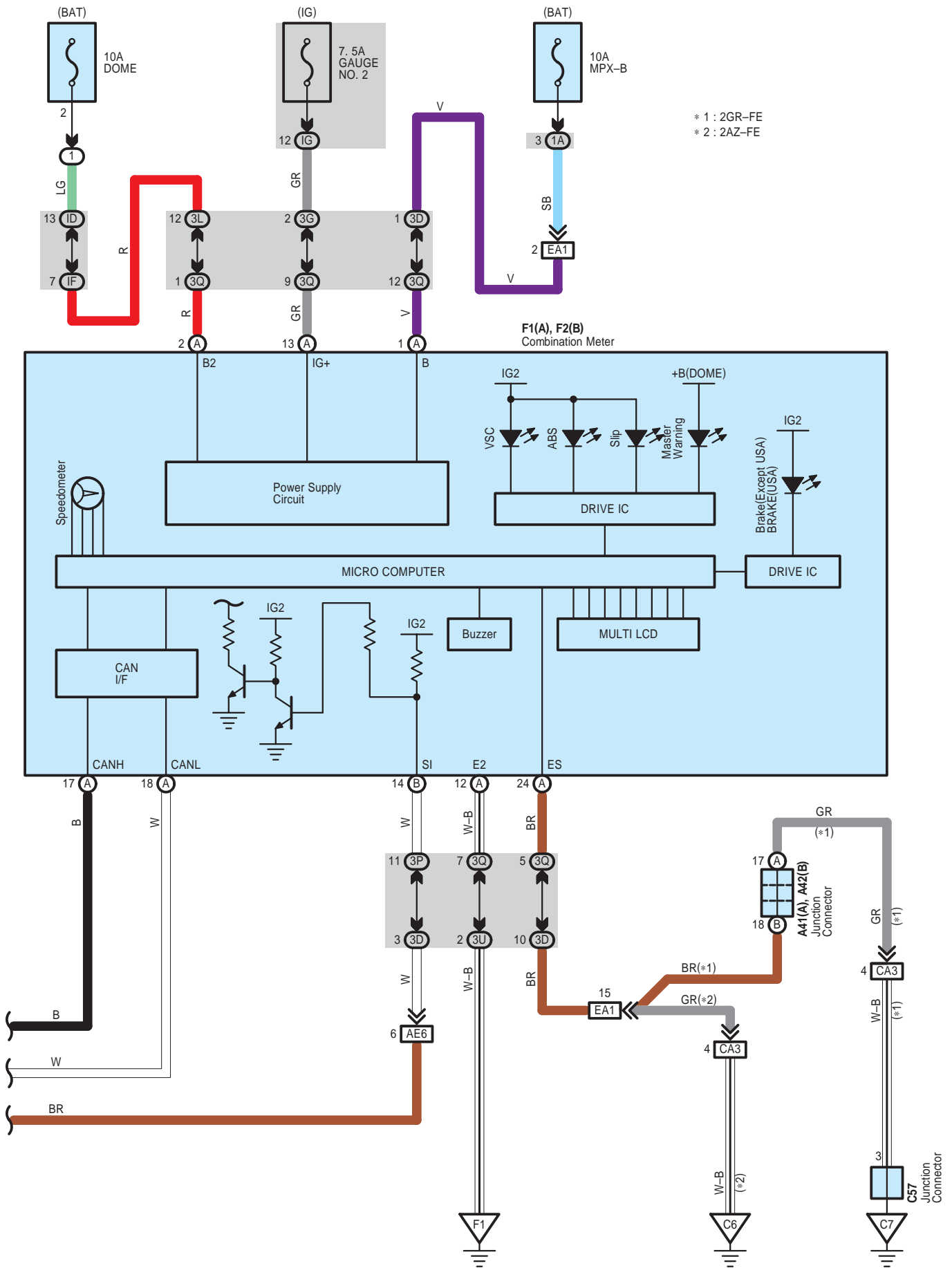

CAMRY (EM0250U)

# ABS, TRAC and VSC (TMC Made)

## System Outline

### 1. ABS Operation

If the brake pedal is depressed suddenly, the ABS controls the hydraulic pressure of the wheel cylinders for all the four wheels to automatically avoid wheel locking and ensure the directional and steering stability of the vehicle. If the brake pedal is depressed suddenly, the skid control ECU controls the solenoids in the actuators using the signals from the sensors to move the brake fluid to the reservoir in order to release the braking pressure applied to the wheel cylinder. If the skid control ECU detects that the fluid pressure in the wheel cylinder is insufficient, the ECU controls the solenoids in the actuators to increase the braking pressure.

### 2. Traction Control Operation

The traction control system controls the engine torque, the hydraulic pressure of the driving wheel cylinders, slipping of the wheels which may occur at start or acceleration of the vehicle, to ensure an optimal driving power and vehicle stability corresponding to the road conditions.

### 3. VSC Operation

Unexpected road conditions, vehicle speed, emergency situation, and any other external factors may cause large under- or over-steering of the vehicle. If this occurs, the VSC system automatically controls the engine power and wheel brakes to reduce the under- or over-steering.

To reduce large over-steering :

If the VSC system determines that the over-steering is large, it activates the brakes for the outer turning wheels depending on the degree of the over-steering to produce the moment toward the outside of the vehicle and reduce the over-steering.

To reduce large under-steering :

If the VSC system determines that the under-steering is large, it controls the engine power and activates the rear wheel brakes to reduce the under-steering.

### 4. Fail Safe Function

If an error occurs in the skid control ECU, sensor signals, and/or actuators, the skid control ECU inhibits the brake actuator control and inputs the error signal to the engine control module. According to the error signal, the brake actuator turns off the solenoid and the engine control module rejects any electronically controlled throttle open request from the VSC system. As a result, the vehicle functions regardless of the ABS, TRAC, and VSC systems.

## ○ : Parts Location

| Code | See Page    | Code        | See Page | Code        | See Page |
|------|-------------|-------------|----------|-------------|----------|
| A14  | 48 (2GR-FE) | C1          | B        | 54 (2AZ-FE) | E40 B 57 |
|      | 52 (2AZ-FE) | C5          |          | 50 (2GR-FE) | E41 B 57 |
| A18  | 59          |             |          | 54 (2AZ-FE) | E42 A 57 |
| A19  | 59          | C20         |          | 55 (2AZ-FE) | E43 B 57 |
| A24  | A           | 52 (2AZ-FE) | C24 B    | 55 (2AZ-FE) | E44 C 57 |
| A26  | 48 (2GR-FE) | C50         |          | 51 (2GR-FE) | E46 E 57 |
|      | 52 (2AZ-FE) | C55         | B        | 51 (2GR-FE) | E49 57   |
| A35  | 48 (2GR-FE) | C57         |          | 51 (2GR-FE) | E62 G 57 |
|      | 52 (2AZ-FE) | E8          | C        | 56          | E63 H 57 |
| A40  | A           | 59          | E10      | 56          | F1 A 58  |
| A41  | A           | 59          | E13      | 56          | F2 B 58  |
| A42  | B           | 59          | E17      | 56          | f1 61    |
| A55  | A           | 49 (2GR-FE) | E31      | 56          | g1 61    |
| A58  | A           | 59          | E33      | 56          |          |
| C1   | A           | 50 (2GR-FE) | E34      | 57          |          |

## ○ : Relay Blocks

| Code | See Page | Relay Blocks (Relay Block Location)       |
|------|----------|---|
| 1    | 22       | Engine Room R/B (Engine Compartment Left) |

 : Junction Block and Wire Harness Connector

| Code | See Page | Junction Block and Wire Harness (Connector Location)                   |
|------|----------|--|
| 1A   | 25       | Engine Room Main Wire and Engine Room J/B (Engine Compartment Left)    |
| 3C   | 36       | Instrument Panel Wire and J/B No.3 (Behind the Combination Meter)      |
| 3D   |          |  |
| 3E   |          |  |
| 3G   |          |  |
| 3H   |          |  |
| 3K   |          |  |
| 3L   |          |  |
| 3P   | 36       | Instrument Panel No.2 Wire and J/B No.3 (Behind the Combination Meter) |
| 3Q   |          |  |
| 3U   |          |  |
| 4A   | 42       | Instrument Panel Wire and J/B No.4 (Instrument Panel Brace Center)     |
| 4B   |          |  |
| 4C   |          |  |
| 4D   |          |  |
| IC   | 30       | Engine Room Main Wire and Instrument Panel J/B (Cowl Side Left)        |
| ID   | 30       | Instrument Panel Wire and Instrument Panel J/B (Cowl Side Left)        |
| IF   | 30       |  |
| IG   | 31       |  |
| IH   |          |  |
| IL   | 30       |  |
| IM   | 30       |  |

 : Connector Joining Wire Harness and Wire Harness

| Code | See Page    | Joining Wire Harness and Wire Harness (Connector Location)                                |
|------|-------------|---|
| AE2  | 66          | Engine Room Main Wire and Instrument Panel Wire (Right Side of the Instrument Panel J/B)  |
| AE5  | 66          | Engine Room Main Wire and Instrument Panel Wire (Instrument Panel Right)                  |
| AE6  |             |   |
| CA2  | 64 (2GR-FE) | Engine Wire and Engine Room Main Wire (Inside of the Engine Room R/B and Engine Room J/B) |
|      | 65 (2AZ-FE) |   |
| CA3  | 64 (2GR-FE) |   |
|      | 65 (2AZ-FE) |   |
| EA1  | 66          | Instrument Panel Wire and Engine Room Main Wire (Left Kick Panel)                         |
| FE3  | 66          | Instrument Panel No.2 Wire and Instrument Panel Wire (Instrument Panel Center)            |
| NA1  | 66          | Floor Wire and Engine Room Main Wire (Left Kick Panel)                                    |
| OA1  | 66          | Floor No.2 Wire and Engine Room Main Wire (Right Kick Panel)                              |
| fO1  | 67          | Skid Control Sensor Wire and Floor No.2 Wire (Quarter Wheel House Panel LH)               |
| gN1  | 67          | Skid Control Sensor Wire and Floor Wire (Quarter Wheel House Panel RH)                    |

 : Ground Points

| Code | See Page    | Ground Points Location                  |
|------|-------------|---|
| A4   | 64 (2GR-FE) | Near the Skid Control ECU with Actuator |
|      | 65 (2AZ-FE) |   |
| A6   | 66          | Right Cowl Side Panel                   |
| C4   | 65 (2AZ-FE) | Cylinder Block                          |
| C5   | 64 (2GR-FE) | Right Side of the Cylinder Block        |
| C6   | 65 (2AZ-FE) | Cylinder Block                          |
| C7   | 64 (2GR-FE) | Left Side of the Cylinder Block         |
| E2   | 66          | Instrument Panel Brace LH               |
| F1   | 66          | Instrument Panel Left                   |

# ABS, TRAC and VSC (TMMK Made)

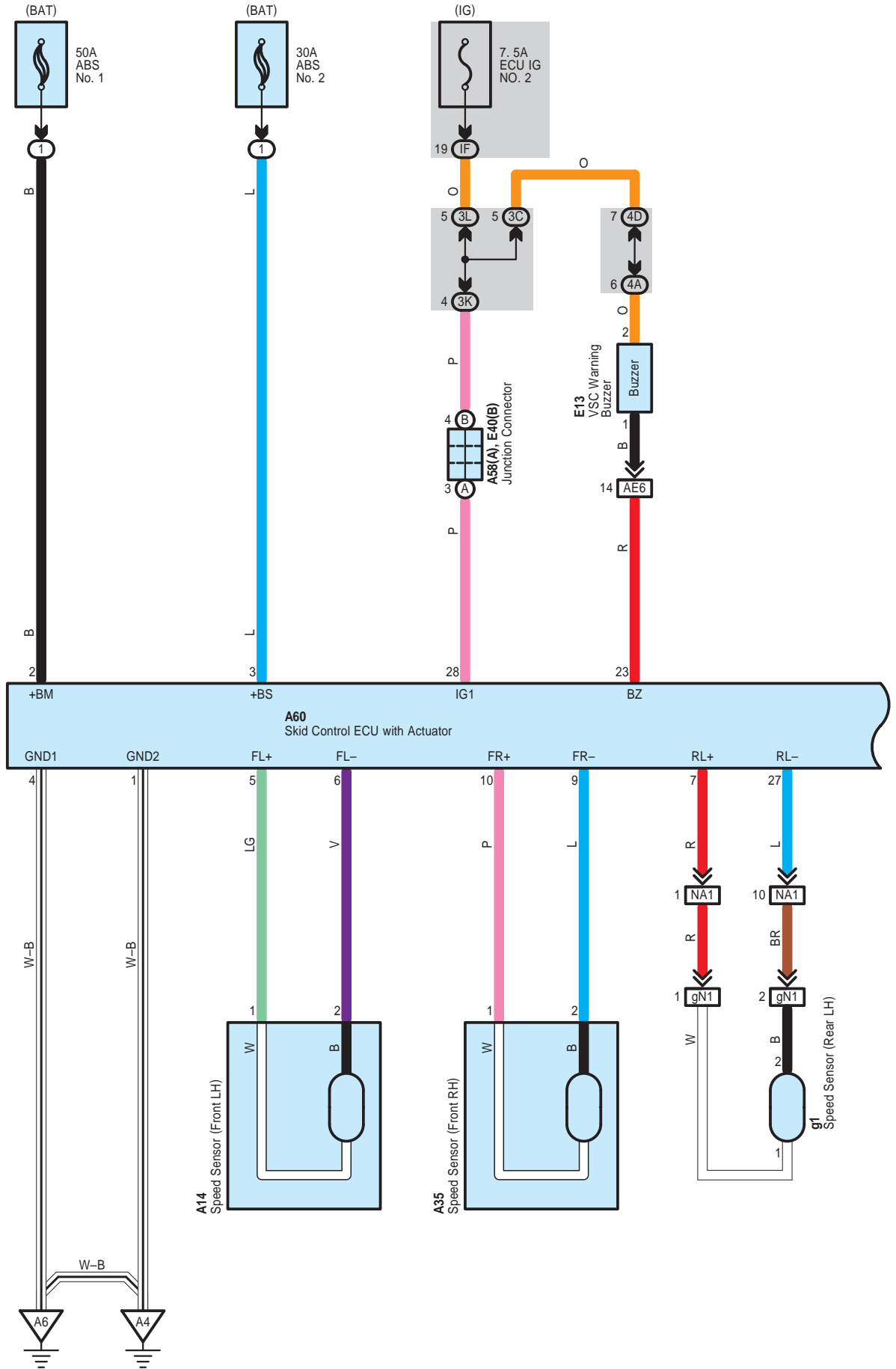

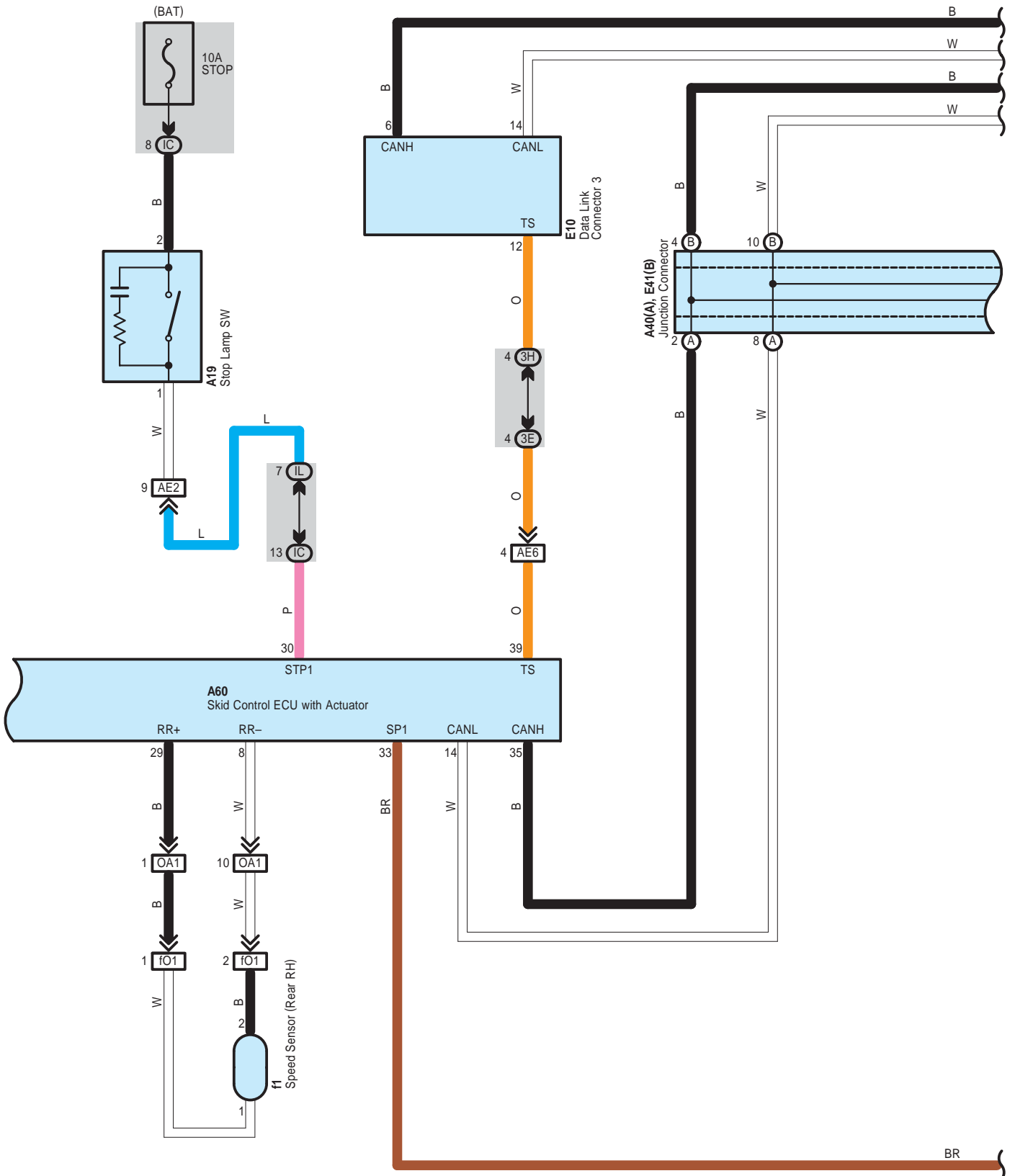

# ABS, TRAC and VSC (TMMK Made)

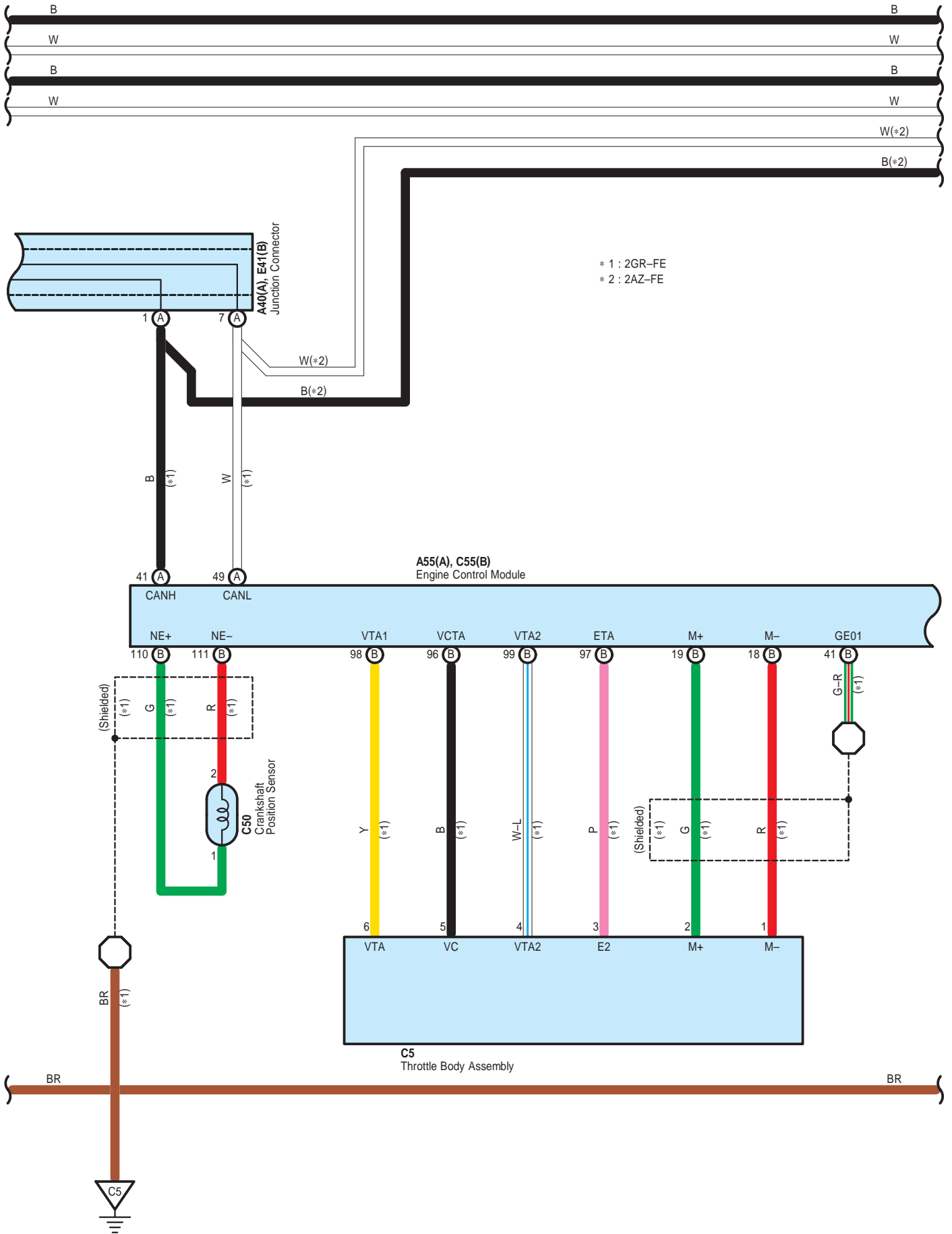

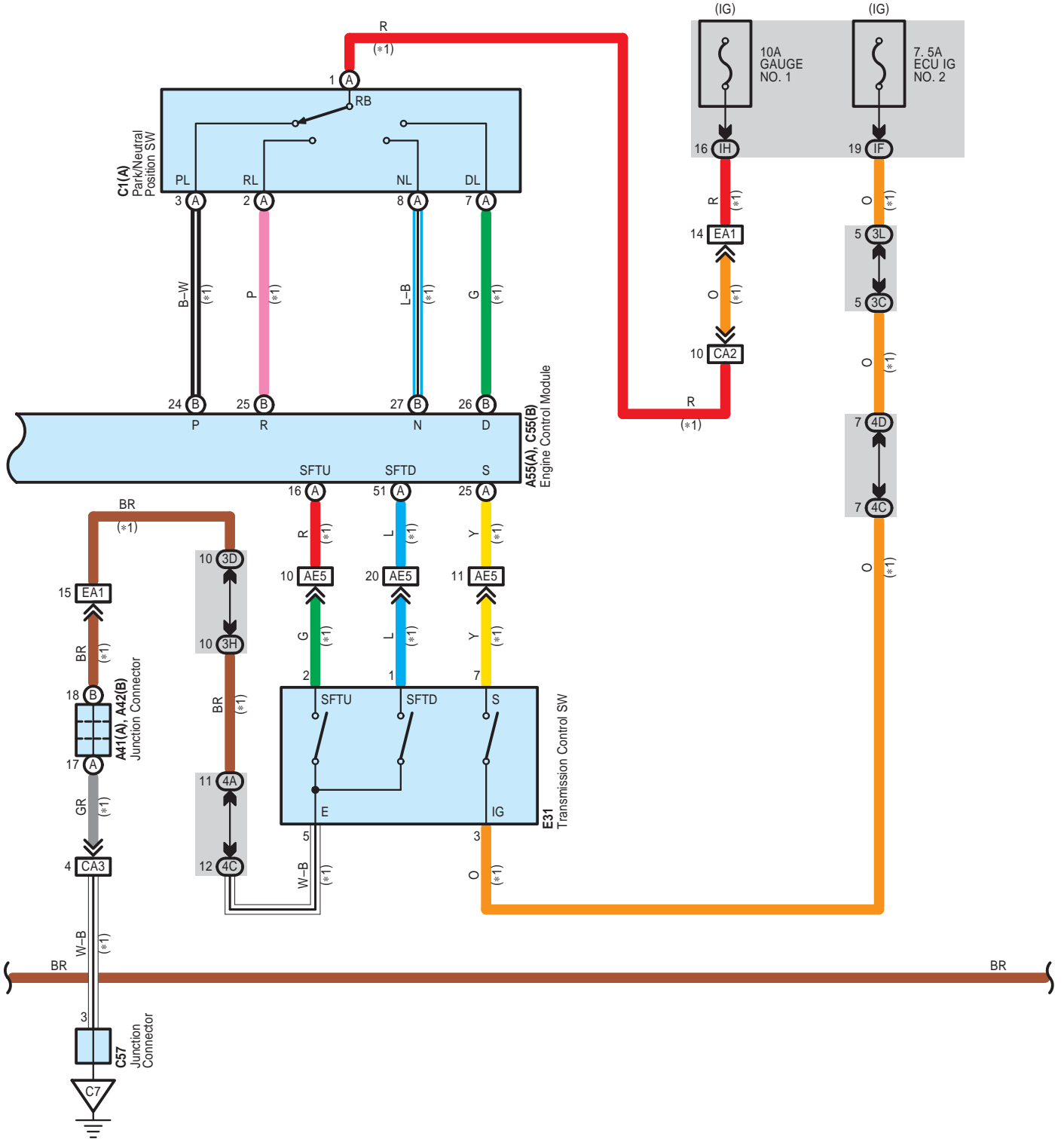
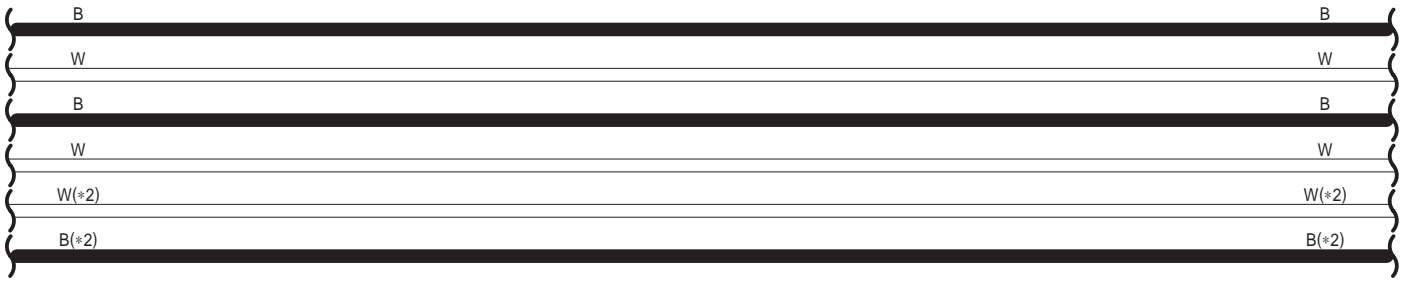



# ABS, TRAC and VSC (TMMK Made)

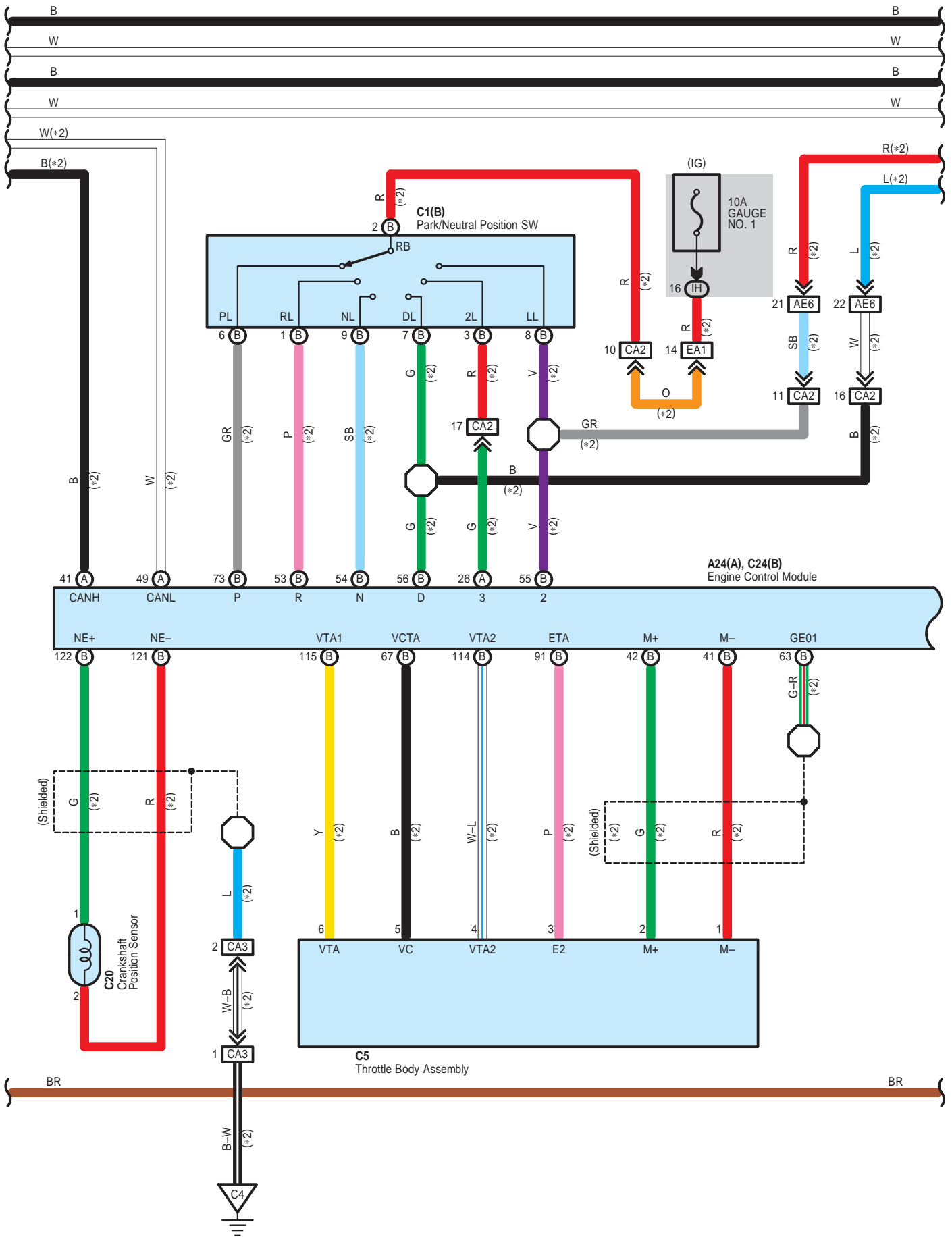

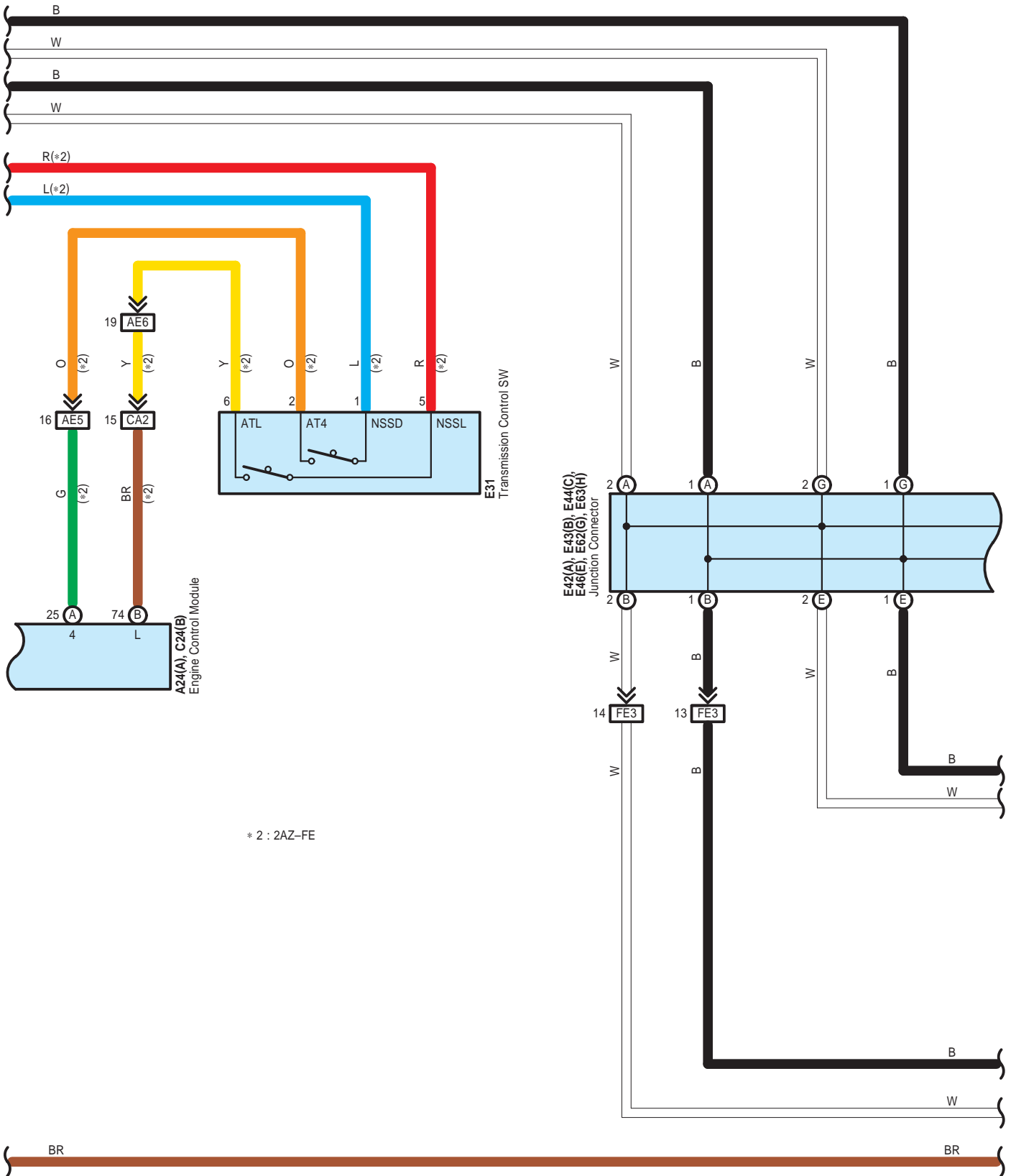

# ABS, TRAC and VSC (TMMK Made)

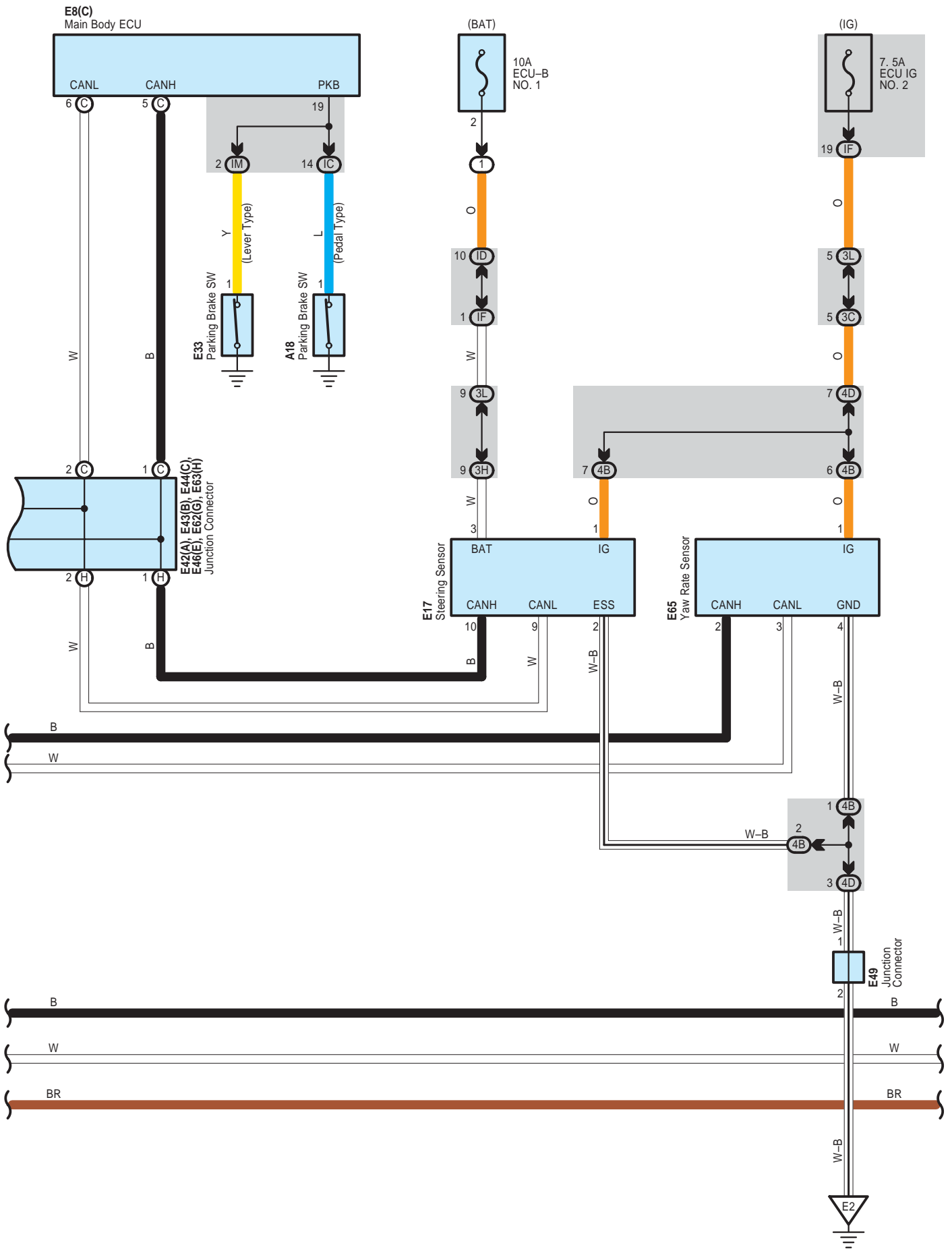

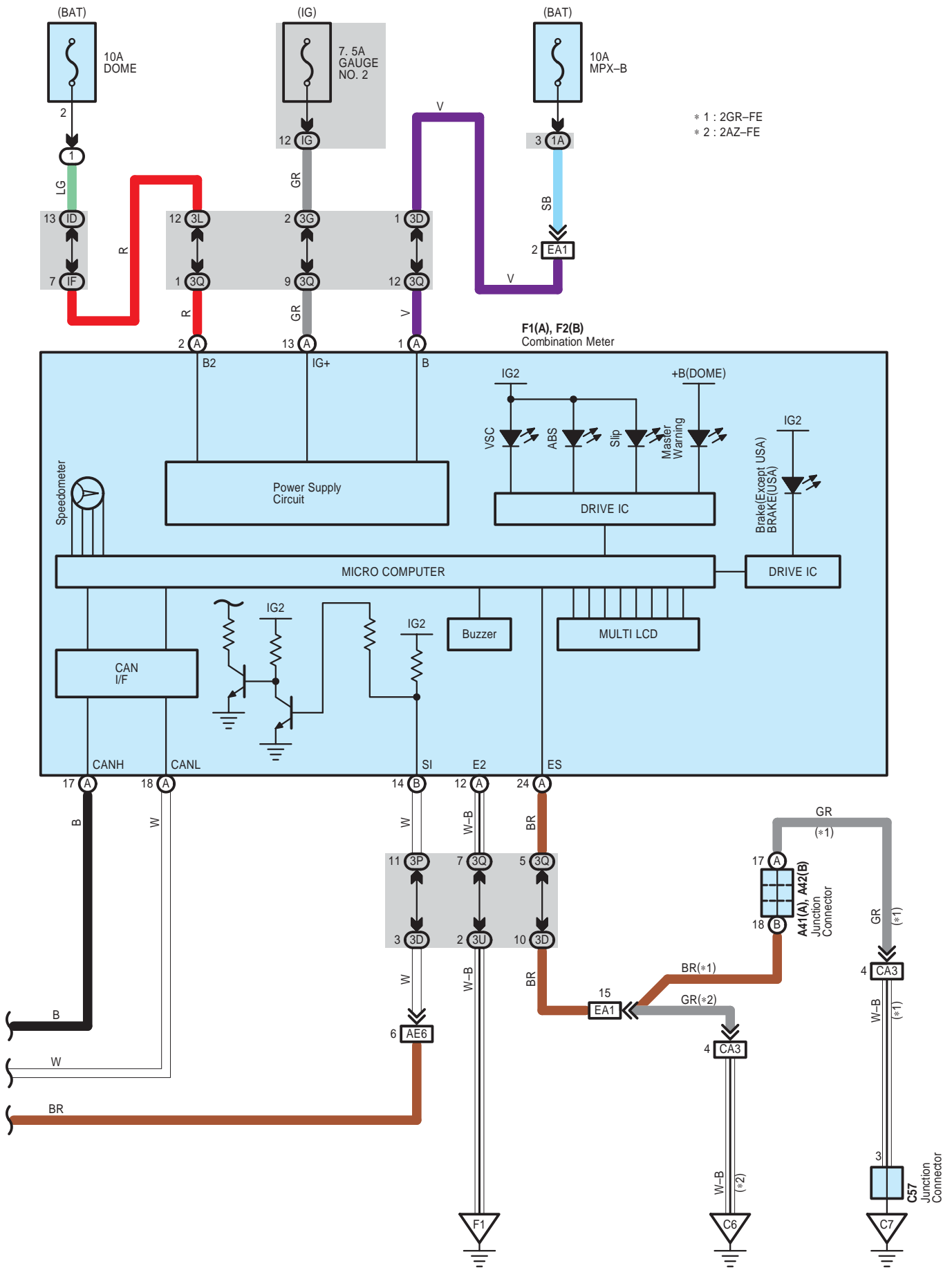

CAMRY (EM0250U)

# ABS, TRAC and VSC (TMMK Made)

## System Outline

### 1. ABS Operation

If the brake pedal is depressed suddenly, the ABS controls the hydraulic pressure of the wheel cylinders for all the four wheels to automatically avoid wheel locking and ensure the directional and steering stability of the vehicle. If the brake pedal is depressed suddenly, the skid control ECU controls the solenoids in the actuators using the signals from the sensors to move the brake fluid to the reservoir in order to release the braking pressure applied to the wheel cylinder. If the skid control ECU detects that the fluid pressure in the wheel cylinder is insufficient, the ECU controls the solenoids in the actuators to increase the braking pressure.

### 2. Traction Control Operation

The traction control system controls the engine torque, the hydraulic pressure of the driving wheel cylinders, slipping of the wheels which may occur at start or acceleration of the vehicle, to ensure an optimal driving power and vehicle stability corresponding to the road conditions.

### 3. VSC Operation

Unexpected road conditions, vehicle speed, emergency situation, and any other external factors may cause large under- or over-steering of the vehicle. If this occurs, the VSC system automatically controls the engine power and wheel brakes to reduce the under- or over-steering.

To reduce large over-steering :

If the VSC system determines that the over-steering is large, it activates the brakes for the outer turning wheels depending on the degree of the over-steering to produce the moment toward the outside of the vehicle and reduce the over-steering.

To reduce large under-steering :

If the VSC system determines that the under-steering is large, it controls the engine power and activates the rear wheel brakes to reduce the under-steering.

### 4. Fail Safe Function

If an error occurs in the skid control ECU, sensor signals, and/or actuators, the skid control ECU inhibits the brake actuator control and inputs the error signal to the engine control module. According to the error signal, the brake actuator turns off the solenoid and the engine control module rejects any electronically controlled throttle open request from the VSC system. As a result, the vehicle functions regardless of the ABS, TRAC, and VSC systems.

## ○ : Parts Location

| Code    | See Page    | Code    | See Page | Code        | See Page     |
|---------|-------------|---------|----------|-------------|--------------|
| A14     | 48 (2GR-FE) | C1      | B        | 54 (2AZ-FE) | E41   B   57 |
|         | 52 (2AZ-FE) | C5      |          | 50 (2GR-FE) | E42   A   57 |
| A18     | 59          |         |          | 54 (2AZ-FE) | E43   B   57 |
| A19     | 59          | C20     |          | 55 (2AZ-FE) | E44   C   57 |
| A24   A | 52 (2AZ-FE) | C24   B |          | 55 (2AZ-FE) | E46   E   57 |
| A35     | 48 (2GR-FE) | C50     |          | 51 (2GR-FE) | E49   57     |
|         | 52 (2AZ-FE) | C55   B |          | 51 (2GR-FE) | E62   G   57 |
| A40   A | 59          | C57     |          | 51 (2GR-FE) | E63   H   57 |
| A41   A | 59          | E8   C  |          | 56          | E65   57     |
| A42   B | 59          | E10     |          | 56          | F1   A   58  |
| A55   A | 49 (2GR-FE) | E13     |          | 56          | F2   B   58  |
| A58   A | 59          | E17     |          | 56          | f1   61      |
| A60     | 49 (2GR-FE) | E31     |          | 56          | g1   61      |
|         | 53 (2AZ-FE) | E33     |          | 56          |              |
| C1   A  | 50 (2GR-FE) | E40   B |          | 57          |              |

## ○ : Relay Blocks

| Code | See Page | Relay Blocks (Relay Block Location)       |
|------|----------|---|
| 1    | 22       | Engine Room R/B (Engine Compartment Left) |

 : Junction Block and Wire Harness Connector

| Code | See Page | Junction Block and Wire Harness (Connector Location)                   |
|------|----------|--|
| 1A   | 25       | Engine Room Main Wire and Engine Room J/B (Engine Compartment Left)    |
| 3C   | 36       | Instrument Panel Wire and J/B No.3 (Behind the Combination Meter)      |
| 3D   |          |  |
| 3E   |          |  |
| 3G   |          |  |
| 3H   |          |  |
| 3K   |          |  |
| 3L   |          |  |
| 3P   | 36       | Instrument Panel No.2 Wire and J/B No.3 (Behind the Combination Meter) |
| 3Q   |          |  |
| 3U   |          |  |
| 4A   | 42       | Instrument Panel Wire and J/B No.4 (Instrument Panel Brace Center)     |
| 4B   |          |  |
| 4C   |          |  |
| 4D   |          |  |
| IC   | 30       | Engine Room Main Wire and Instrument Panel J/B (Cowl Side Left)        |
| ID   | 30       | Instrument Panel Wire and Instrument Panel J/B (Cowl Side Left)        |
| IF   | 30       |  |
| IG   | 31       |  |
| IH   |          |  |
| IL   | 30       |  |
| IM   | 30       |  |

 : Connector Joining Wire Harness and Wire Harness

| Code | See Page    | Joining Wire Harness and Wire Harness (Connector Location)                                |
|------|-------------|---|
| AE2  | 66          | Engine Room Main Wire and Instrument Panel Wire (Right Side of the Instrument Panel J/B)  |
| AE5  | 66          | Engine Room Main Wire and Instrument Panel Wire (Instrument Panel Right)                  |
| AE6  |             |   |
| CA2  | 64 (2GR-FE) | Engine Wire and Engine Room Main Wire (Inside of the Engine Room R/B and Engine Room J/B) |
|      | 65 (2AZ-FE) |   |
| CA3  | 64 (2GR-FE) |   |
|      | 65 (2AZ-FE) |   |
| EA1  | 66          | Instrument Panel Wire and Engine Room Main Wire (Left Kick Panel)                         |
| FE3  | 66          | Instrument Panel No.2 Wire and Instrument Panel Wire (Instrument Panel Center)            |
| NA1  | 66          | Floor Wire and Engine Room Main Wire (Left Kick Panel)                                    |
| OA1  | 66          | Floor No.2 Wire and Engine Room Main Wire (Right Kick Panel)                              |
| fO1  | 67          | Skid Control Sensor Wire and Floor No.2 Wire (Quarter Wheel House Panel LH)               |
| gN1  | 67          | Skid Control Sensor Wire and Floor Wire (Quarter Wheel House Panel RH)                    |

 : Ground Points

| Code | See Page    | Ground Points Location                  |
|------|-------------|---|
| A4   | 64 (2GR-FE) | Near the Skid Control ECU with Actuator |
|      | 65 (2AZ-FE) |   |
| A6   | 66          | Right Cowl Side Panel                   |
| C4   | 65 (2AZ-FE) | Cylinder Block                          |
| C5   | 64 (2GR-FE) | Right Side of the Cylinder Block        |
| C6   | 65 (2AZ-FE) | Cylinder Block                          |
| C7   | 64 (2GR-FE) | Left Side of the Cylinder Block         |
| E2   | 66          | Instrument Panel Brace LH               |
| F1   | 66          | Instrument Panel Left                   |

# ABS without VSC

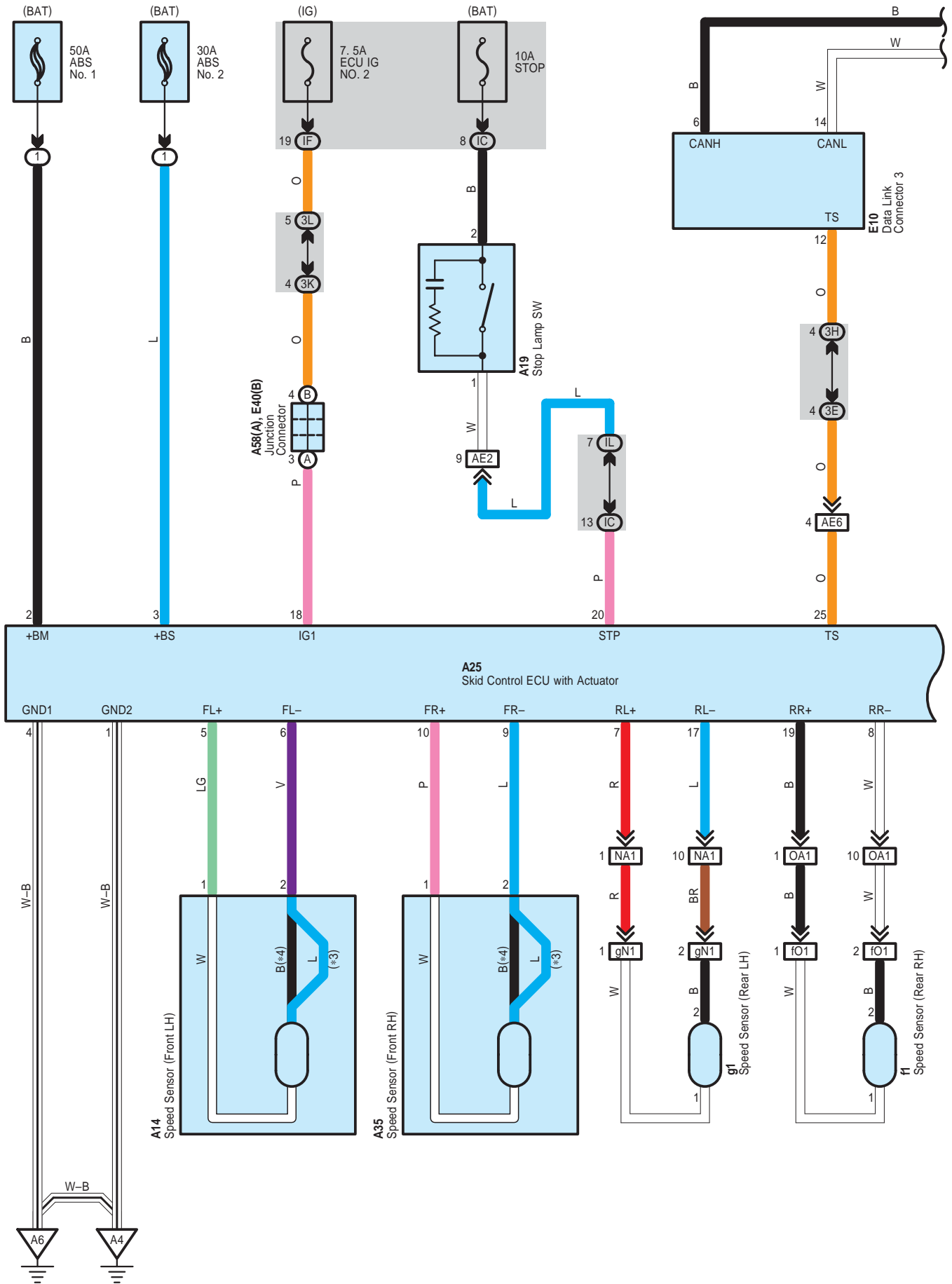

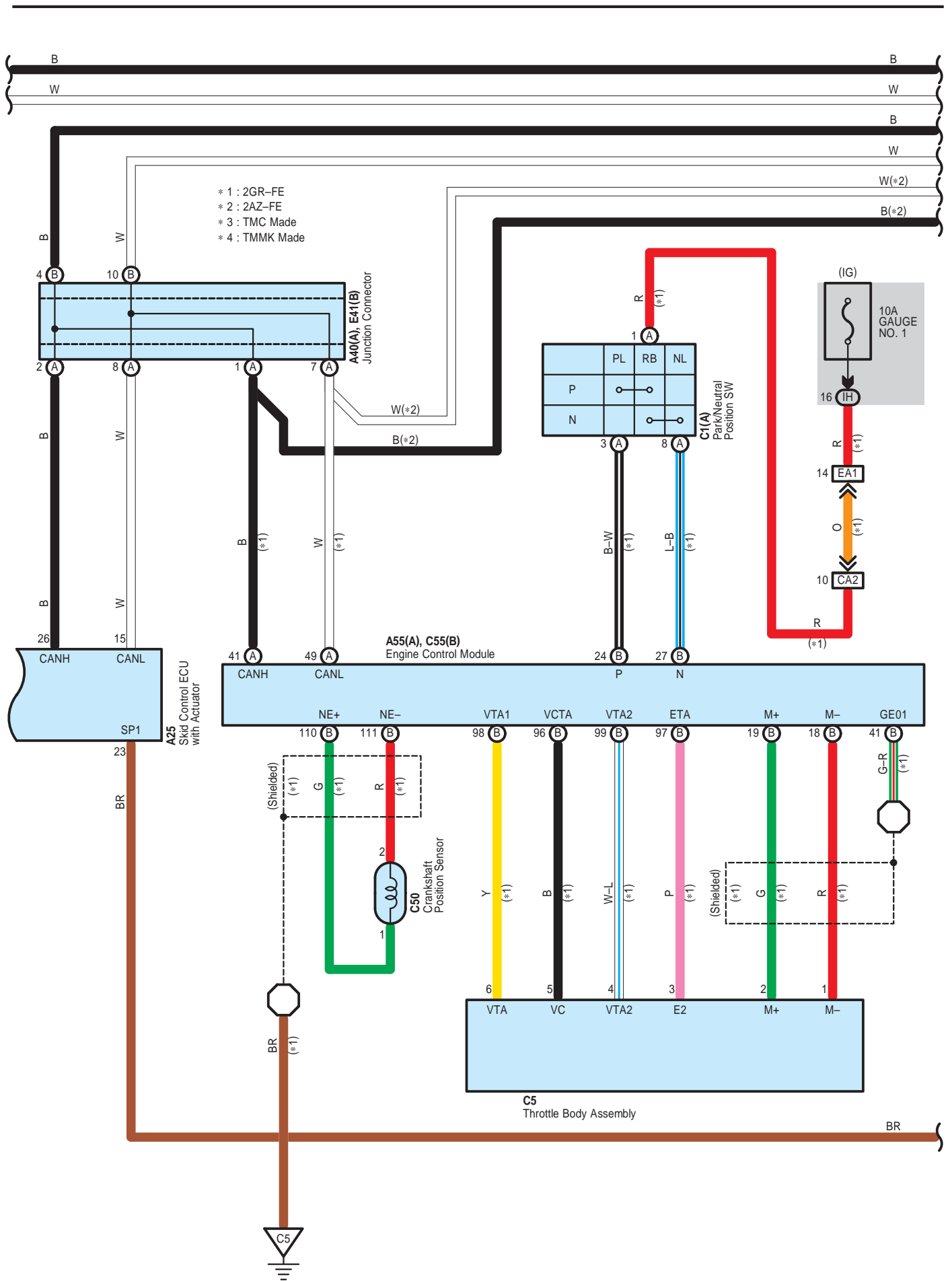



# ABS without VSC

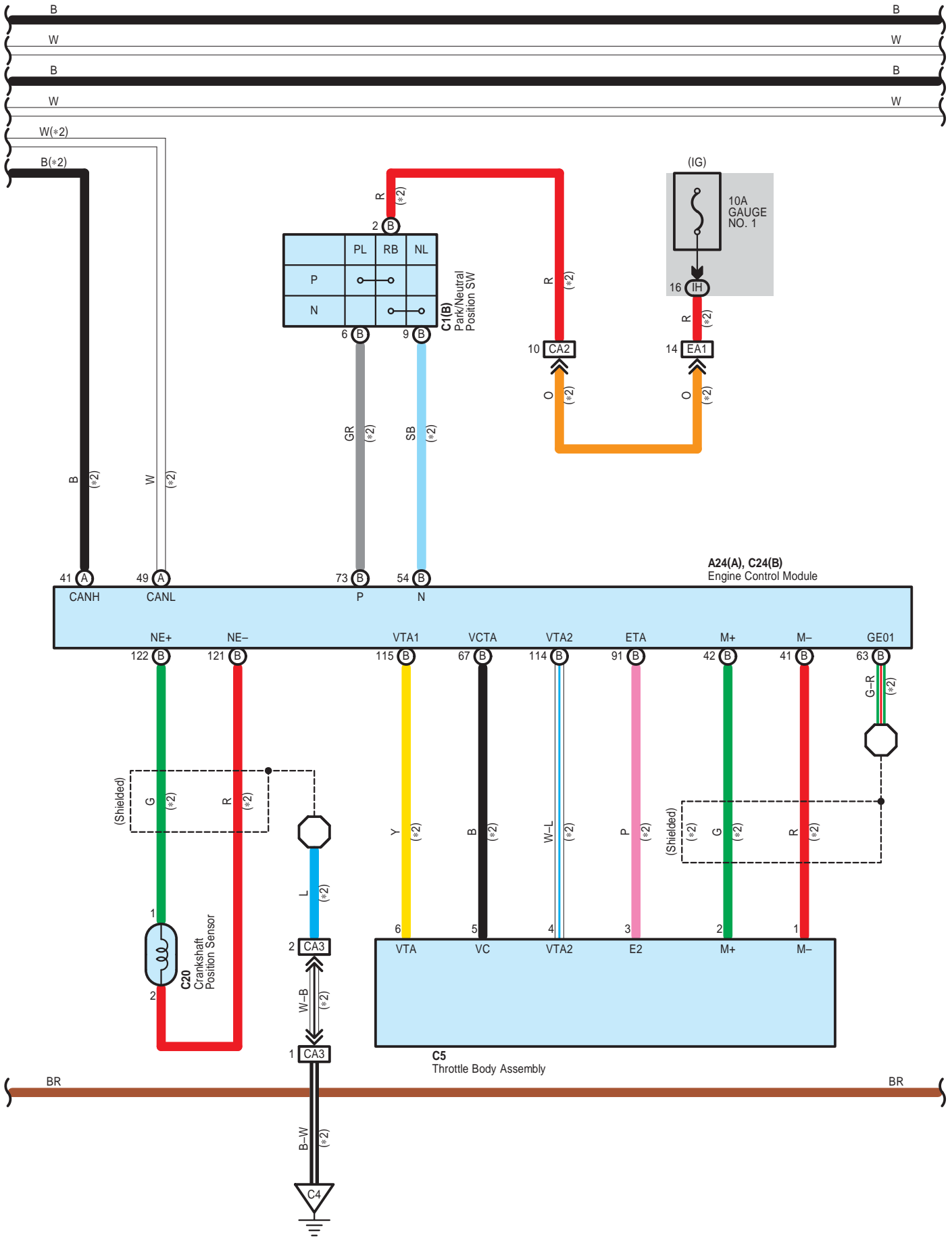

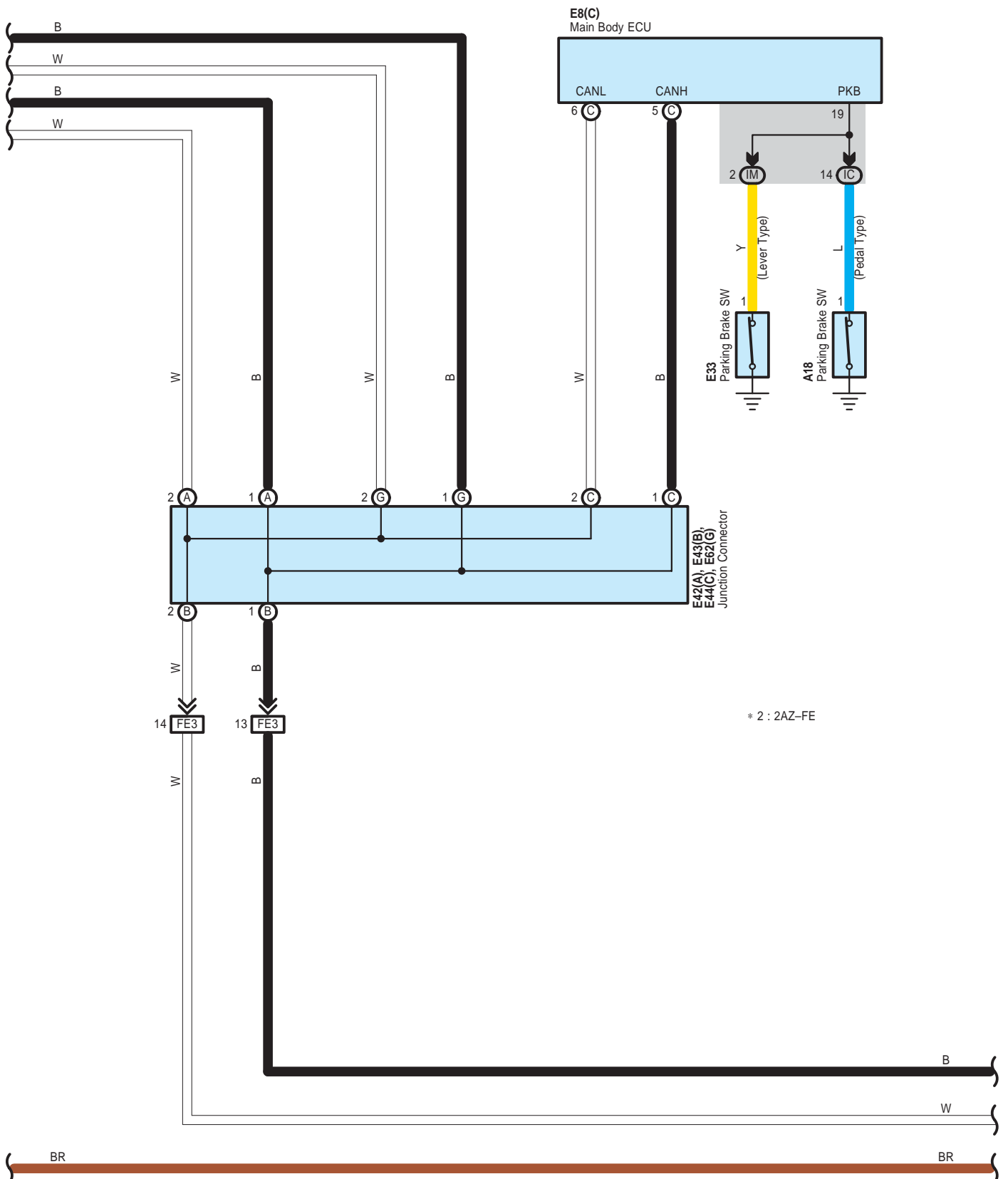

# ABS without VSC

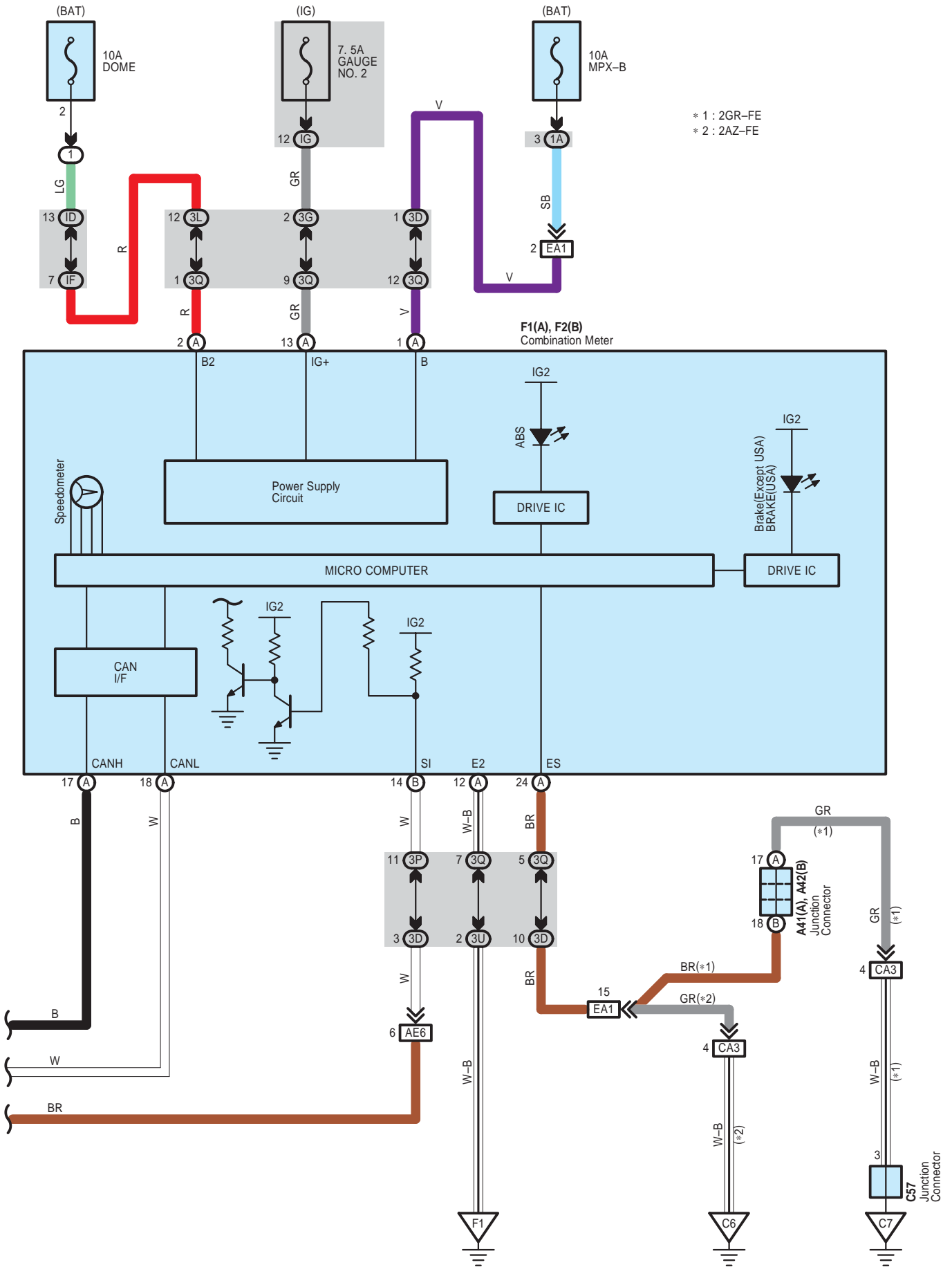

## System Outline

### \* ABS system

This system controls the respective brake fluid pressures acting on the disc brake cylinders of the right front wheel, left front wheel and rear wheels when the brakes are applied in a panic stop so that the wheels do not lock. This results in improved directional stability and steerability during panic braking.

### \* Front and rear braking force distribution system

Using the hydraulic controlling device, this system distributes the braking force to the front and rear wheel in appropriately according to the running condition of the vehicle.

## 1. Input Signals

### (1) Speed sensor signal

The speed of the wheels is detected and input to TERMINALS 5, 7, 10 and 19 of the skid control ECU with actuator.

### (2) Stop light SW signal

A signal is input to TERMINAL 20 of the skid control ECU with actuator when the brake pedal is depressed.

## 2. System Operation

During sudden braking the skid control ECU with actuator has signals input from each sensor, which controls the current to the solenoid inside the actuator and lets the hydraulic pressure acting on each wheel cylinder escape to the reservoir. The pump inside the actuator is also operating at this time and it returns the brake fluid from the reservoir to the master cylinder, thus preventing locking of the vehicle wheels.

If the skid control ECU with actuator judges that the hydraulic pressure acting on the wheel cylinder is insufficient, the current on the solenoid is controlled and the hydraulic pressure is increased. Holding of the hydraulic pressure is also controlled by the skid control ECU with actuator, by the same method as above. Pressure reduction, holding and increase are repeated to maintain vehicle stability and to improve steerability during sudden braking.

## ○ : Parts Location

| Code | See Page    | Code | See Page | Code        | See Page    |     |    |
|------|-------------|------|----------|-------------|-------------|-----|----|
| A14  | 48 (2GR-FE) | A55  | A        | 49 (2GR-FE) | E10         | 56  |    |
|      | 52 (2AZ-FE) | A58  | A        | 59          | E33         | 56  |    |
| A18  | 59          | C1   | A        | 50 (2GR-FE) | E40         | B   | 57 |
| A19  | 59          |      | B        | 54 (2AZ-FE) | E41         | B   | 57 |
| A24  | A           | C5   |          | 50 (2GR-FE) | E42         | A   | 57 |
| A25  | 48 (2GR-FE) |      |          |             | 54 (2AZ-FE) | E43 | B  |
|      | 52 (2AZ-FE) | C20  |          | 55 (2AZ-FE) | E44         | C   | 57 |
| A35  | 48 (2GR-FE) | C24  | B        | 55 (2AZ-FE) | E62         | G   | 57 |
|      | 52 (2AZ-FE) | C50  |          | 51 (2GR-FE) | F1          | A   | 58 |
| A40  | A           | C55  | B        | 51 (2GR-FE) | F2          | B   | 58 |
| A41  | A           | C57  |          | 51 (2GR-FE) | f1          |     | 61 |
| A42  | B           | E8   | C        | 56          | g1          |     | 61 |

## ○ : Relay Blocks

| Code | See Page | Relay Blocks (Relay Block Location)       |
|------|----------|---|
| 1    | 22       | Engine Room R/B (Engine Compartment Left) |

# ABS without VSC

## : Junction Block and Wire Harness Connector

| Code | See Page | Junction Block and Wire Harness (Connector Location)                   |
|------|----------|--|
| 1A   | 25       | Engine Room Main Wire and Engine Room J/B (Engine Compartment Left)    |
| 3D   | 36       | Instrument Panel Wire and J/B No.3 (Behind the Combination Meter)      |
| 3E   |          |  |
| 3G   |          |  |
| 3H   |          |  |
| 3K   |          |  |
| 3L   |          |  |
| 3P   | 36       | Instrument Panel No.2 Wire and J/B No.3 (Behind the Combination Meter) |
| 3Q   |          |  |
| 3U   |          |  |
| IC   | 30       | Engine Room Main Wire and Instrument Panel J/B (Cowl Side Left)        |
| ID   |          |  |
| IF   | 30       | Instrument Panel Wire and Instrument Panel J/B (Cowl Side Left)        |
| IG   | 31       |  |
| IH   |          |  |
| IL   | 30       |  |
| IM   |          |  |

## : Connector Joining Wire Harness and Wire Harness

| Code | See Page    | Joining Wire Harness and Wire Harness (Connector Location)                                |
|------|-------------|---|
| AE2  | 66          | Engine Room Main Wire and Instrument Panel Wire (Right Side of the Instrument Panel J/B)  |
| AE6  | 66          | Engine Room Main Wire and Instrument Panel Wire (Instrument Panel Right)                  |
| CA2  | 64 (2GR-FE) | Engine Wire and Engine Room Main Wire (Inside of the Engine Room R/B and Engine Room J/B) |
|      | 65 (2AZ-FE) |   |
| CA3  | 64 (2GR-FE) |   |
|      | 65 (2AZ-FE) |   |
| EA1  | 66          | Instrument Panel Wire and Engine Room Main Wire (Left Kick Panel)                         |
| FE3  | 66          | Instrument Panel No.2 Wire and Instrument Panel Wire (Instrument Panel Center)            |
| NA1  | 66          | Floor Wire and Engine Room Main Wire (Left Kick Panel)                                    |
| OA1  | 66          | Floor No.2 Wire and Engine Room Main Wire (Right Kick Panel)                              |
| fO1  | 67          | Skid Control Sensor Wire and Floor No.2 Wire (Quarter Wheel House Panel LH)               |
| gN1  | 67          | Skid Control Sensor Wire and Floor Wire (Quarter Wheel House Panel RH)                    |

## : Ground Points

| Code | See Page    | Ground Points Location                  |
|------|-------------|---|
| A4   | 64 (2GR-FE) | Near the Skid Control ECU with Actuator |
|      | 65 (2AZ-FE) |   |
| A6   | 66          | Right Cowl Side Panel                   |
| C4   | 65 (2AZ-FE) | Cylinder Block                          |
| C5   | 64 (2GR-FE) | Right Side of the Cylinder Block        |
| C6   | 65 (2AZ-FE) | Cylinder Block                          |
| C7   | 64 (2GR-FE) | Left Side of the Cylinder Block         |
| F1   | 66          | Instrument Panel Left                   |



# Tire Pressure Warning System

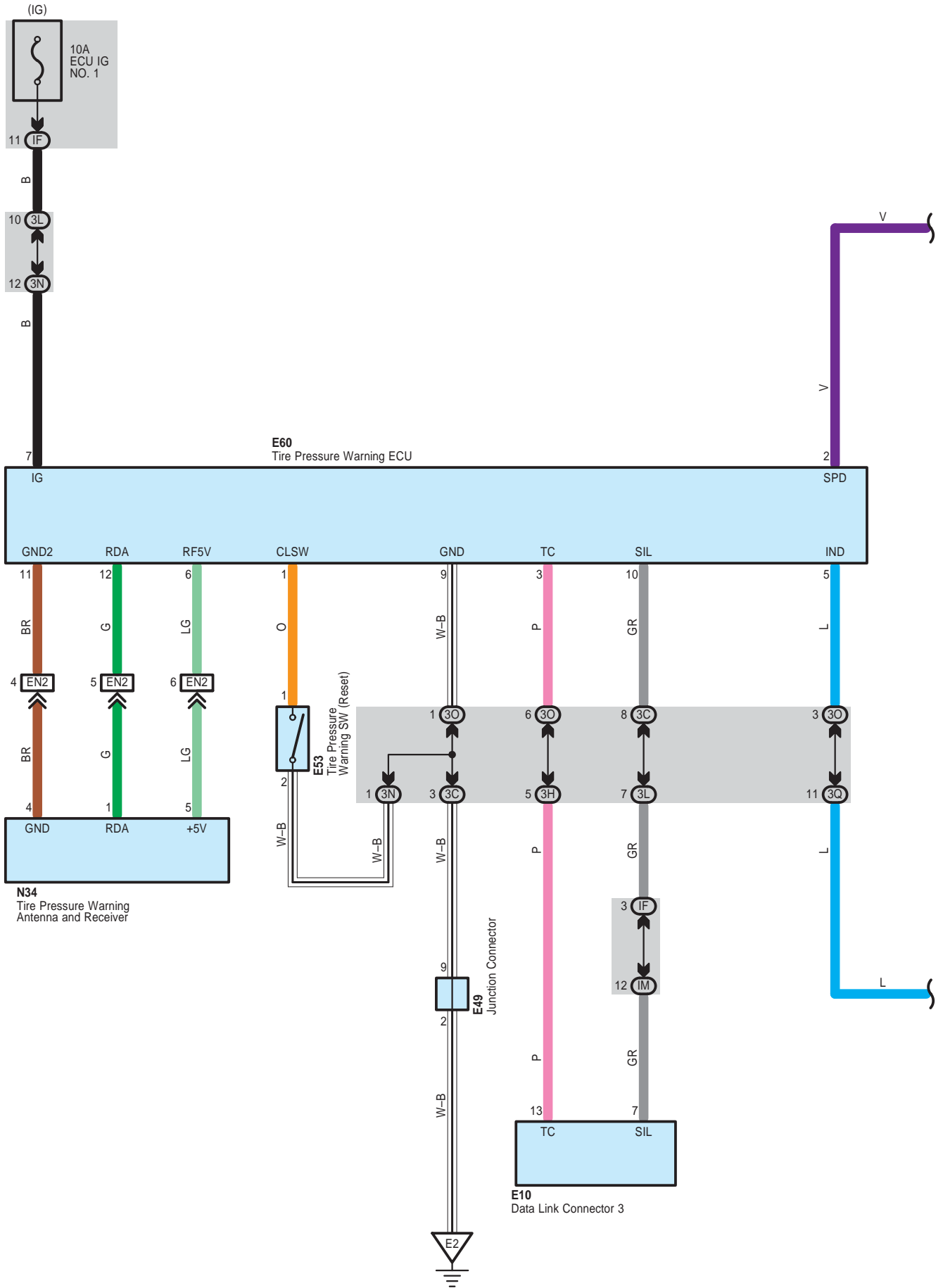

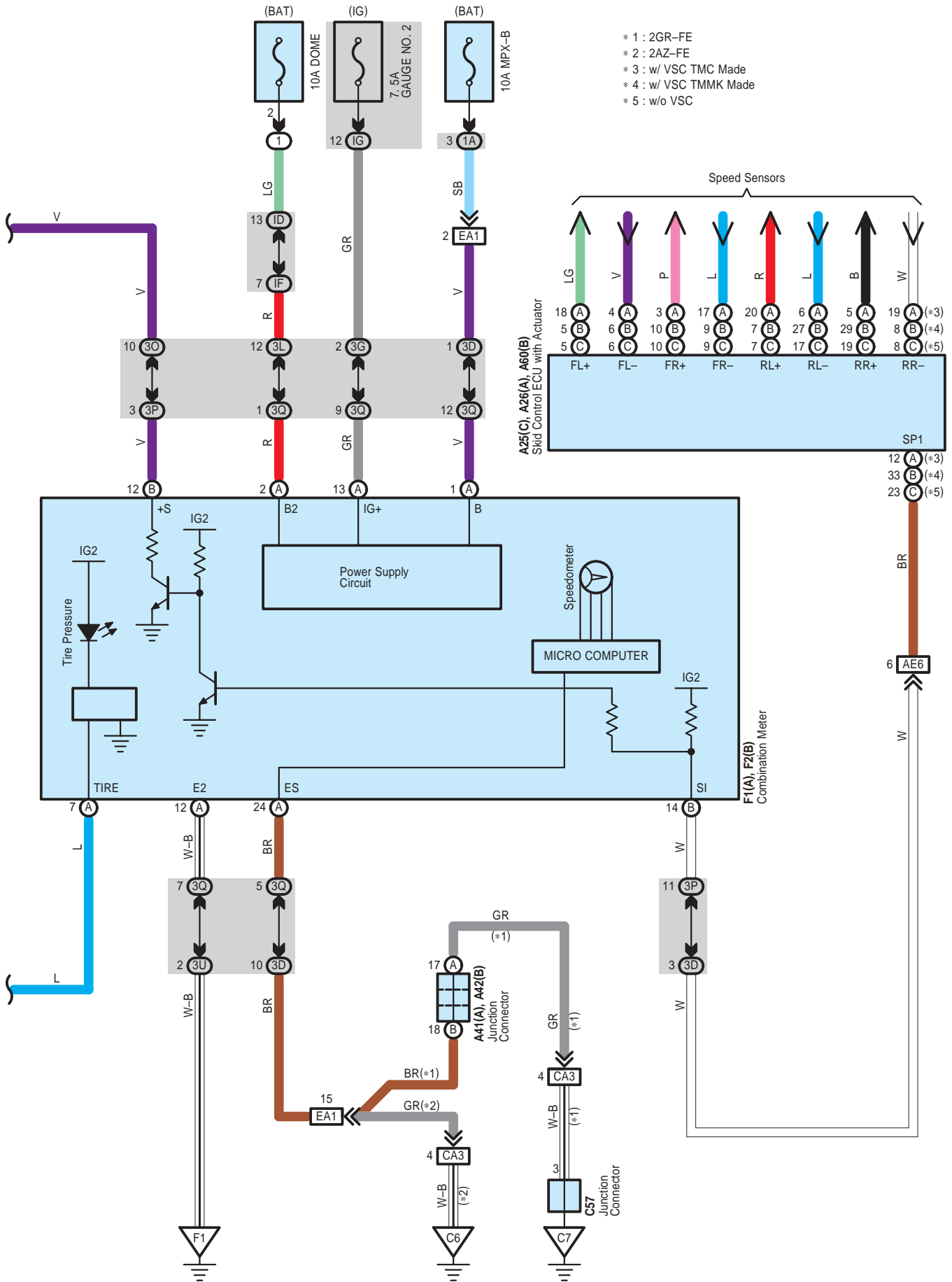



# Tire Pressure Warning System

## ○ : Parts Location

| Code |   | See Page    | Code |    | See Page    | Code |    | See Page |
|------|---|-------------|------|----|-------------|------|----|----------|
| A25  | C | 48 (2GR-FE) | A60  | B  | 49 (2GR-FE) | E60  |    | 57       |
|      |   | 52 (2AZ-FE) |      |    | 53 (2AZ-FE) | F1   | A  | 58       |
| A26  | A | 48 (2GR-FE) | C57  |    | 51 (2GR-FE) | F2   | B  | 58       |
|      |   | 52 (2AZ-FE) | E10  | 56 | N34         |      | 60 |          |
| A41  | A | 59          | E49  |    | 57          |      |    |          |
| A42  | B | 59          | E53  |    | 57          |      |    |          |

## ○ : Relay Blocks

| Code | See Page | Relay Blocks (Relay Block Location)       |
|------|----------|---|
| 1    | 22       | Engine Room R/B (Engine Compartment Left) |

## ○ : Junction Block and Wire Harness Connector

| Code | See Page | Junction Block and Wire Harness (Connector Location)                   |
|------|----------|--|
| 1A   | 25       | Engine Room Main Wire and Engine Room J/B (Engine Compartment Left)    |
| 3C   | 36       | Instrument Panel Wire and J/B No.3 (Behind the Combination Meter)      |
| 3D   |          |  |
| 3G   |          |  |
| 3H   |          |  |
| 3L   |          |  |
| 3N   |          |  |
| 3O   |          |  |
| 3P   | 36       | Instrument Panel No.2 Wire and J/B No.3 (Behind the Combination Meter) |
| 3Q   |          |  |
| 3U   |          |  |
| ID   | 30       | Engine Room Main Wire and Instrument Panel J/B (Cowl Side Left)        |
| IF   | 30       | Instrument Panel Wire and Instrument Panel J/B (Cowl Side Left)        |
| IG   | 31       |  |
| IM   | 30       |  |

## □ : Connector Joining Wire Harness and Wire Harness

| Code | See Page    | Joining Wire Harness and Wire Harness (Connector Location)                                |
|------|-------------|---|
| AE6  | 66          | Engine Room Main Wire and Instrument Panel Wire (Instrument Panel Right)                  |
| CA3  | 64 (2GR-FE) | Engine Wire and Engine Room Main Wire (Inside of the Engine Room R/B and Engine Room J/B) |
|      | 65 (2AZ-FE) |   |
| EA1  | 66          | Instrument Panel Wire and Engine Room Main Wire (Left Kick Panel)                         |
| EN2  | 66          | Instrument Panel Wire and Floor Wire (Left Kick Panel)                                    |

## ▽ : Ground Points

| Code | See Page    | Ground Points Location          |
|------|-------------|---------------------------------|
| C6   | 65 (2AZ-FE) | Cylinder Block                  |
| C7   | 64 (2GR-FE) | Left Side of the Cylinder Block |
| E2   | 66          | Instrument Panel Brace LH       |
| F1   | 66          | Instrument Panel Left           |

NOTICE: When inspecting or repairing the SRS, perform service in accordance with the following precautionary instructions and the procedure, and precautions in the Repair Manual applicable for the model year.

- Malfunction symptoms of the SRS are difficult to confirm, so the DTCs become the most important source of information when troubleshooting. When troubleshooting the SRS, always inspect the DTCs before disconnecting the battery.
- **Work must be started more than 90 seconds after the ignition SW is turned to the "LOCK" position (Ignition SW type) or the power SW is pushed to the "OFF" position (Power SW type) and the negative (-) terminal cable is disconnected from the battery.**  
**(The SRS is equipped with a back-up power source so that if work is started within 90 seconds from disconnecting the negative (-) terminal cable of the battery, the SRS may deploy.)**
- When the negative (-) terminal cable is disconnected from the battery, the memory of the clock and audio system will be cleared. So before starting work, make a record of the contents in the audio memory system. When work is finished, reset the audio systems as they were before and adjust the clock. Some vehicles have power tilt steering, power telescopic steering, power seat and power outside rear view mirror which are all equipped with memory function. However, it is not possible to make a record of these memory contents. So when the work is finished, it will be necessary to explain it to your customer, and ask the customer to adjust the features and reset the memory. To avoid erasing the memory in each system, never use a back-up power supply from outside the vehicle.
- Before repair, remove the airbag sensor if shocks are likely to be applied to the sensor during repair.
- Do not expose the following parts directly to hot air or flame;
- Even in cases of a minor collision where the SRS does not deploy, the following parts should be inspected;
- Never use SRS parts from another vehicle. When replacing parts, replace with new parts.
- For the purpose of reuse, never disassemble and repair the following parts.
- If the following parts have been dropped, or have cracks, dents and other defects in their case, bracket, and connector, replace with new one.
- Use a volt/ohmmeter with high impedance (10 k $\Omega$ /V minimum) for troubleshooting electrical circuits of the system.
- Information labels are attached to the periphery of the SRS components. Follow the instructions of the notice.
- After work on the SRS is completed, check the SRS warning light.
- If the vehicle is equipped with a mobile communication system, refer to the precaution in the IN section of the Repair Manual.

- \* Steering wheel pad
- \* Front passenger airbag assembly
- \* Side airbag assembly
- \* Curtain shield airbag assembly
- \* Knee airbag assembly
- \* Seat belt pretensioner
- \* Center airbag sensor assembly
- \* Front airbag sensor assembly
- \* Side airbag sensor assembly
- \* Rear airbag sensor assembly

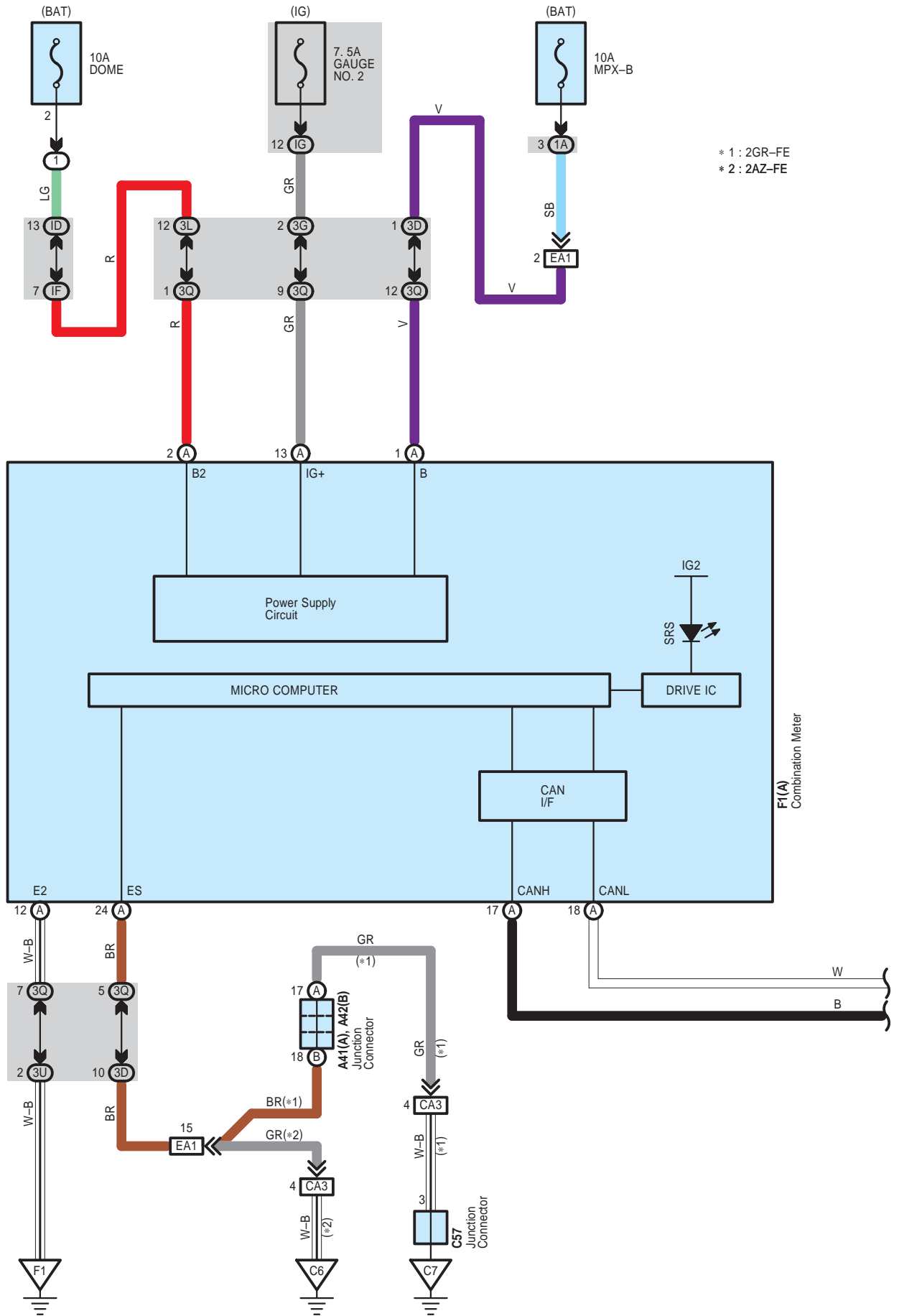

\* 1 : 2GR-FE  
 \* 2 : 2AZ-FE

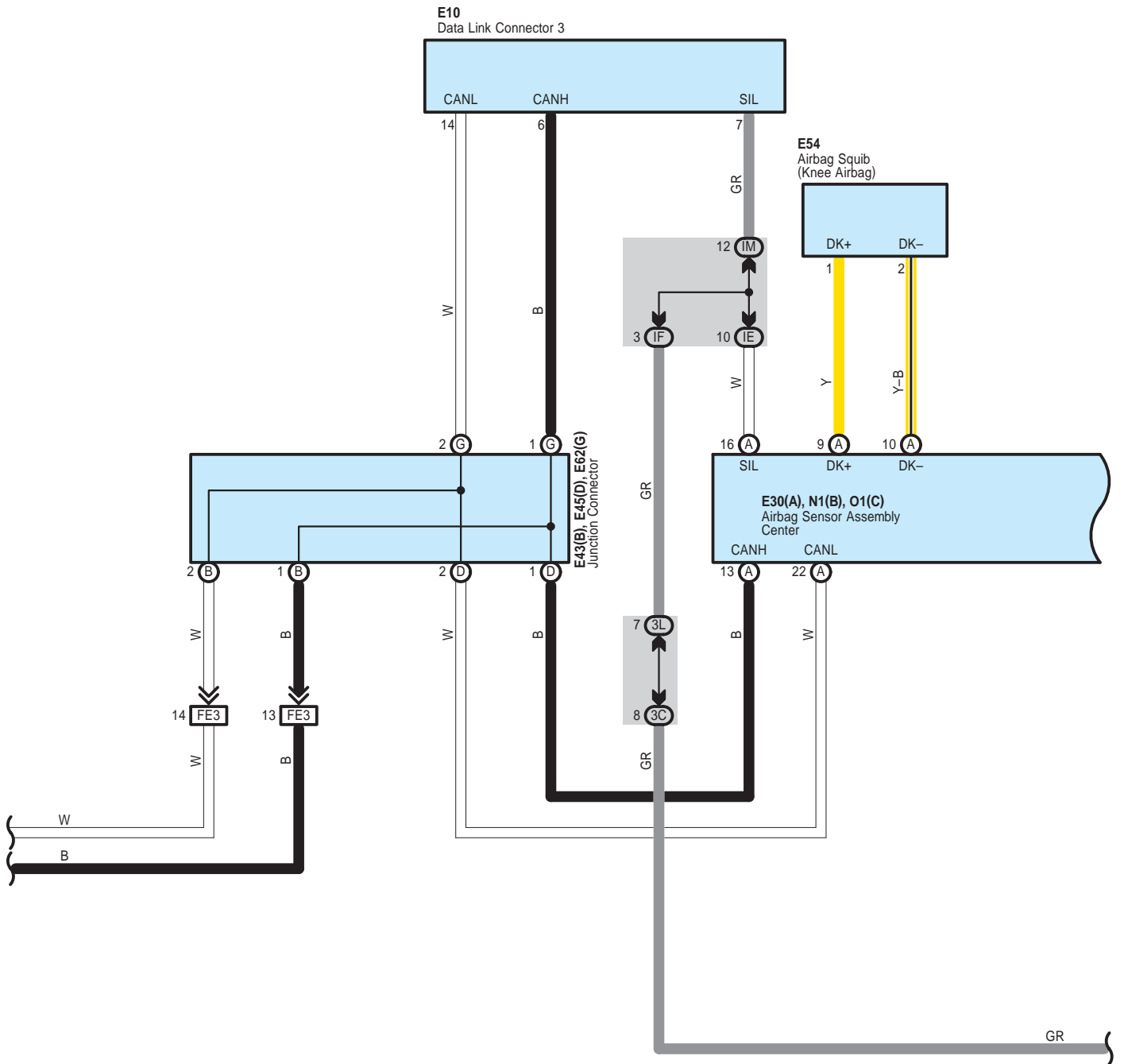

\* 3 : w/ Power Seat  
 \* 4 : w/o Power Seat

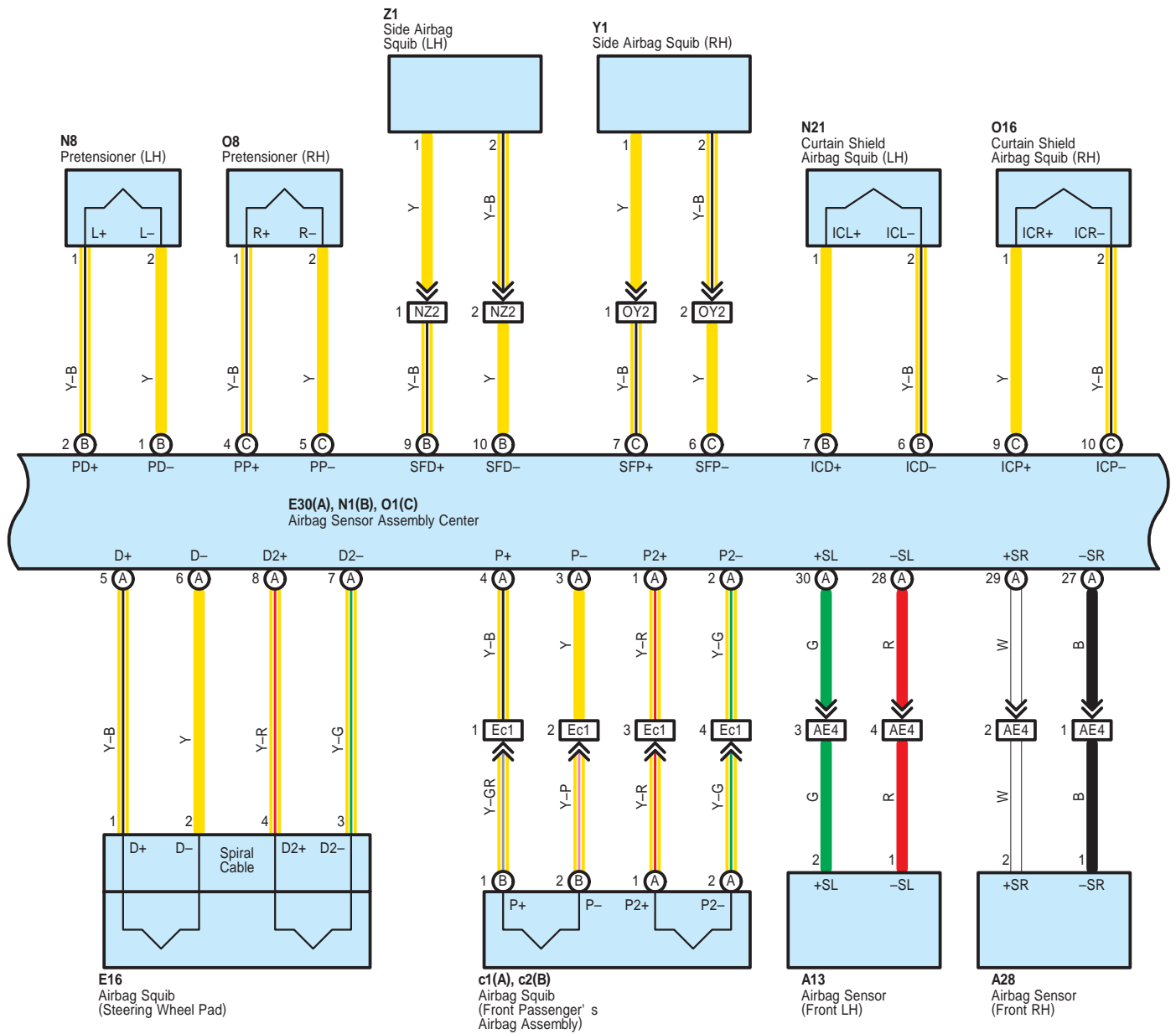

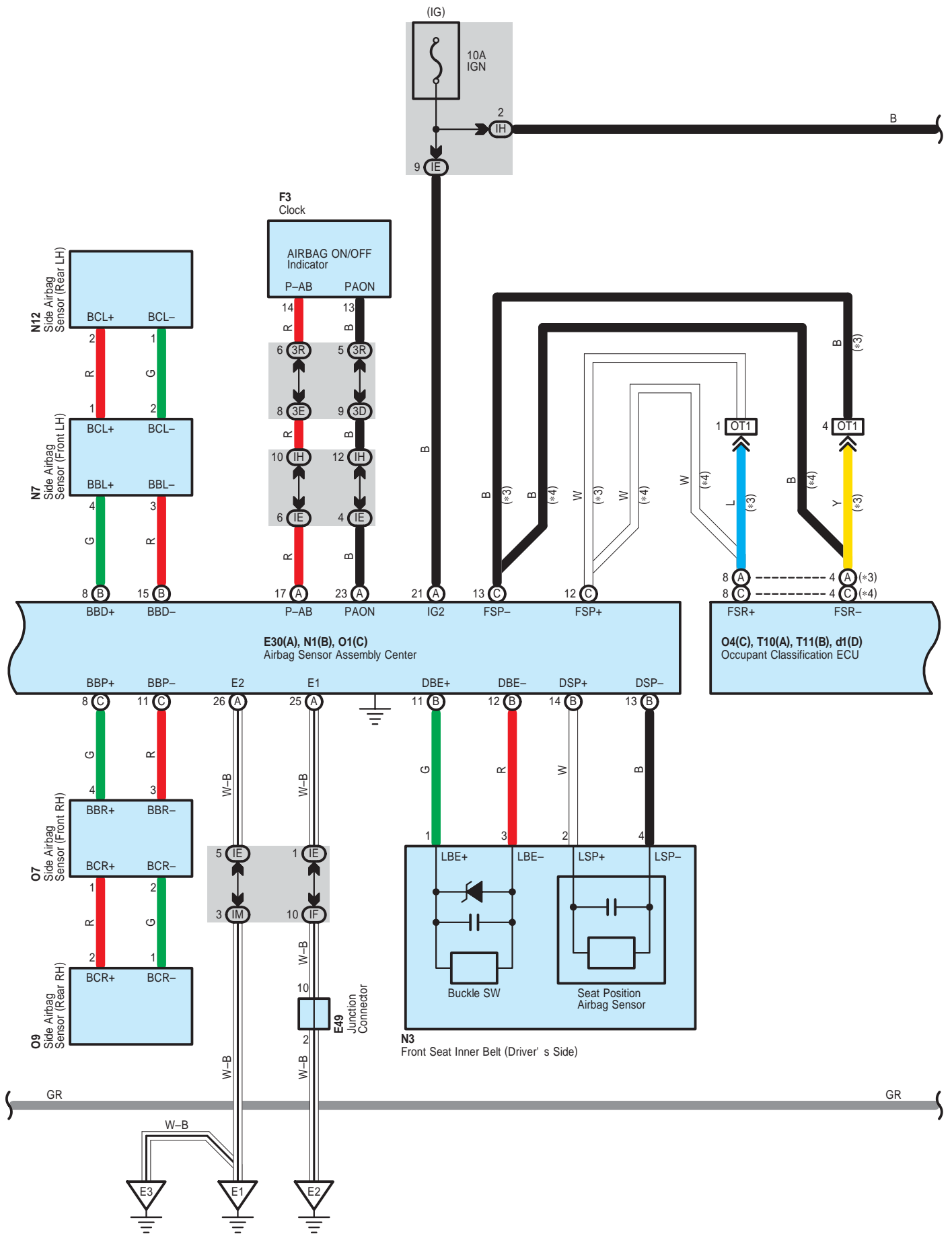

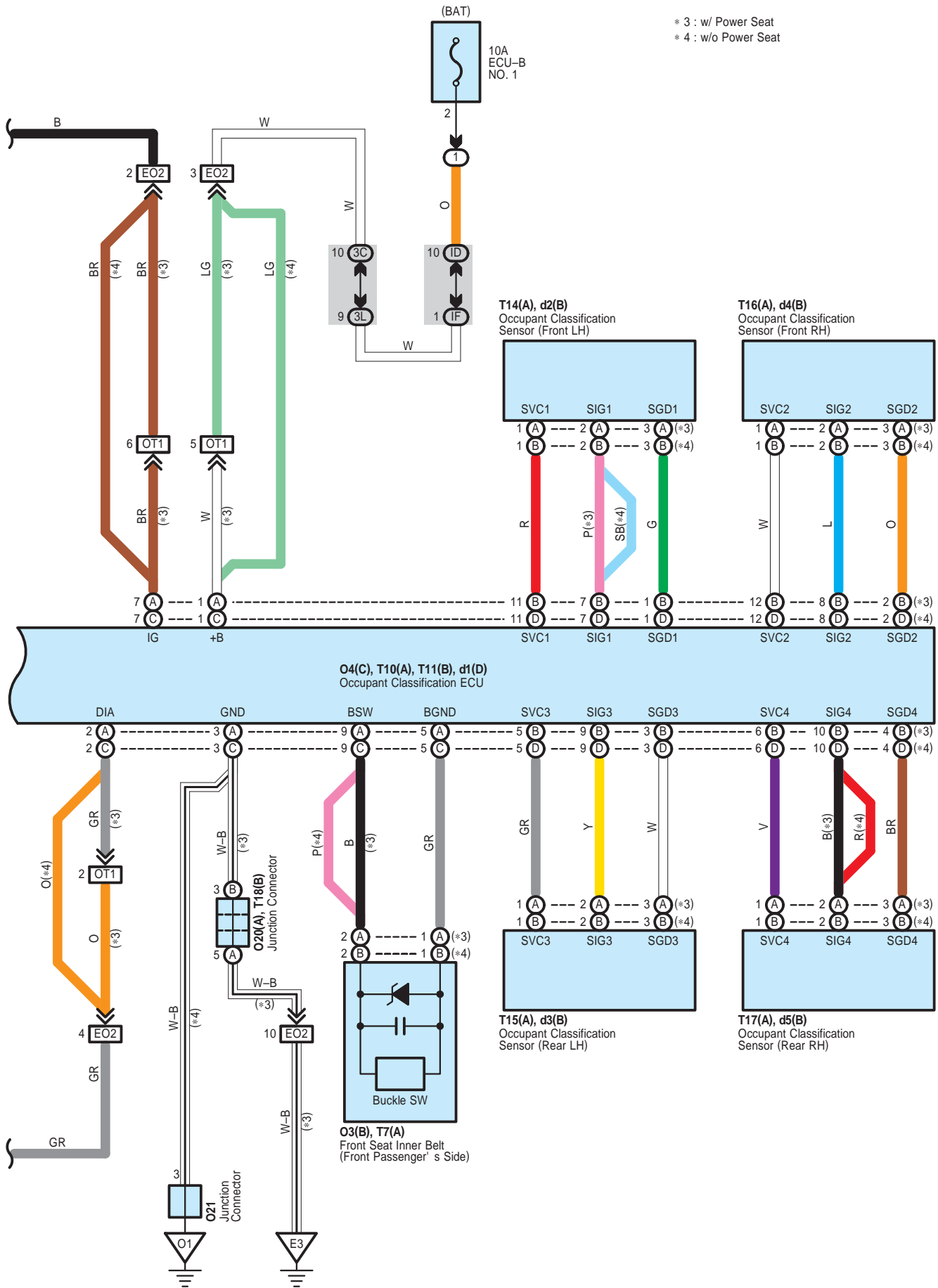

## System Outline

- \* The system reaches an ignition judgment to deploy the following device based on the signals received from the front airbag sensor and deceleration sensor.
  - Driver Airbag
  - Front Passenger Airbag
  - Knee Airbag
  - Seat Belt Pretensioner
- \* The system reaches an ignition judgment to deploy the following device based on the signals received from the side airbag sensors.
  - Side Airbags
  - Curtain Shield Airbags
- \* The dual-stage SRS airbag system has been used for the driver and front passenger airbags. This system controls the optimal airbag inflation by judging the extent of impact, seat position (driver seat) and whether or not the seat belt is fastened(driver seat) and information from the Front Passenger Occupant Classification System.
- \* The front passenger occupant classification system judges whether the front passenger seat is occupied by an adult or child (with child seat) or is unoccupied, according to the load applied to the front passenger seat and whether the seat belt is buckled. Based on the results, it restricts the deployment of the front passenger airbag, front passenger side airbag, and front passenger seat belt pretensioner. In addition, the system informs the driver of the result of the judgment through the use of the AIRBAG ON/OFF indicator lights.

## ○ : Parts Location

| Code |   | See Page    | Code |   | See Page | Code |   | See Page |
|------|---|-------------|------|---|----------|------|---|----------|
| A13  |   | 48 (2GR-FE) | N3   |   | 62 (*1)  | T14  | A | 62 (*1)  |
|      |   | 52 (2AZ-FE) |      |   | 63 (*2)  | T15  | A | 62 (*1)  |
| A28  |   | 48 (2GR-FE) | N7   |   | 60       | T16  | A | 62 (*1)  |
|      |   | 52 (2AZ-FE) | N8   |   | 60       | T17  | A | 62 (*1)  |
| A41  | A | 59          | N12  |   | 60       | T18  | B | 62 (*1)  |
| A42  | B | 59          | N21  |   | 60       | Y1   |   | 62 (*1)  |
| C57  |   | 51 (2GR-FE) | O1   | C | 59       |      |   | 63 (*2)  |
| E10  |   | 56          | O3   | B | 63 (*2)  | Z1   |   | 62 (*1)  |
| E16  |   | 56          | O4   | C | 63 (*2)  |      |   | 63 (*2)  |
| E30  | A | 56          | O7   |   | 60       | c1   | A | 59       |
| E43  | B | 57          | O8   |   | 60       | c2   | B | 59       |
| E45  | D | 57          | O9   |   | 60       | d1   | D | 63 (*2)  |
| E49  |   | 57          | O16  |   | 60       | d2   | B | 63 (*2)  |
| E54  |   | 57          | O20  | A | 62 (*1)  | d3   | B | 63 (*2)  |
| E62  | G | 57          | O21  |   | 60       | d4   | B | 63 (*2)  |
| F1   | A | 58          | T7   | A | 62 (*1)  | d5   | B | 63 (*2)  |
| F3   |   | 58          | T10  | A | 62 (*1)  |      |   |          |
| N1   | B | 59          | T11  | B | 62 (*1)  |      |   |          |

## ○ : Relay Blocks

| Code | See Page | Relay Blocks (Relay Block Location)       |
|------|----------|---|
| 1    | 22       | Engine Room R/B (Engine Compartment Left) |

\* 1 : w/ Power Seat      \* 2 : w/o Power Seat



 : Junction Block and Wire Harness Connector

| Code | See Page | Junction Block and Wire Harness (Connector Location)                   |
|------|----------|--|
| 1A   | 25       | Engine Room Main Wire and Engine Room J/B (Engine Compartment Left)    |
| 3C   | 36       | Instrument Panel Wire and J/B No.3 (Behind the Combination Meter)      |
| 3D   |          |  |
| 3E   |          |  |
| 3G   |          |  |
| 3L   |          |  |
| 3Q   | 36       | Instrument Panel No.2 Wire and J/B No.3 (Behind the Combination Meter) |
| 3R   |          |  |
| 3U   |          |  |
| ID   | 30       | Engine Room Main Wire and Instrument Panel J/B (Cowl Side Left)        |
| IE   | 30       | Instrument Panel Wire and Instrument Panel J/B (Cowl Side Left)        |
| IF   |          |  |
| IG   | 31       |  |
| IH   |          |  |
| IM   |          |  |

 : Connector Joining Wire Harness and Wire Harness

| Code | See Page    | Joining Wire Harness and Wire Harness (Connector Location)                                |
|------|-------------|---|
| AE4  | 66          | Engine Room Main Wire and Instrument Panel Wire (Instrument Panel Right)                  |
| CA3  | 64 (2GR-FE) | Engine Wire and Engine Room Main Wire (Inside of the Engine Room R/B and Engine Room J/B) |
|      | 65 (2AZ-FE) |   |
| EA1  | 66          | Instrument Panel Wire and Engine Room Main Wire (Left Kick Panel)                         |
| EO2  | 66          | Instrument Panel Wire and Floor No.2 Wire (Right Kick Panel)                              |
| Ec1  | 66          | Instrument Panel Wire and Instrument Panel Wire Assembly (Behind The Glove Box)           |
| FE3  | 66          | Instrument Panel No.2 Wire and Instrument Panel Wire (Instrument Panel Center)            |
| NZ2  | 68 (*1)     | Floor Wire and Front Seat Airbag Assembly LH (Under the Driver's Seat)                    |
|      | 69 (*2)     |   |
| OT1  | 68 (*1)     | Floor No.2 Wire and Front Seat RH Wire (Under the Front Passenger's Seat)                 |
| OY2  | 68 (*1)     | Floor No.2 Wire and Front Seat Airbag Assembly RH (Under the Front Passenger's Seat)      |
|      | 69 (*2)     |   |

 : Ground Points

| Code | See Page    | Ground Points Location          |
|------|-------------|---------------------------------|
| C6   | 65 (2AZ-FE) | Cylinder Block                  |
| C7   | 64 (2GR-FE) | Left Side of the Cylinder Block |
| E1   | 66          | Instrument Panel Left           |
| E2   | 66          | Instrument Panel Brace LH       |
| E3   | 66          | Instrument Panel Right          |
| F1   | 66          | Instrument Panel Left           |
| O1   | 67          | Right Rear Quarter Panel        |

\* 1 : w/ Power Seat      \* 2 : w/o Power Seat



# Cruise Control for 2GR-FE

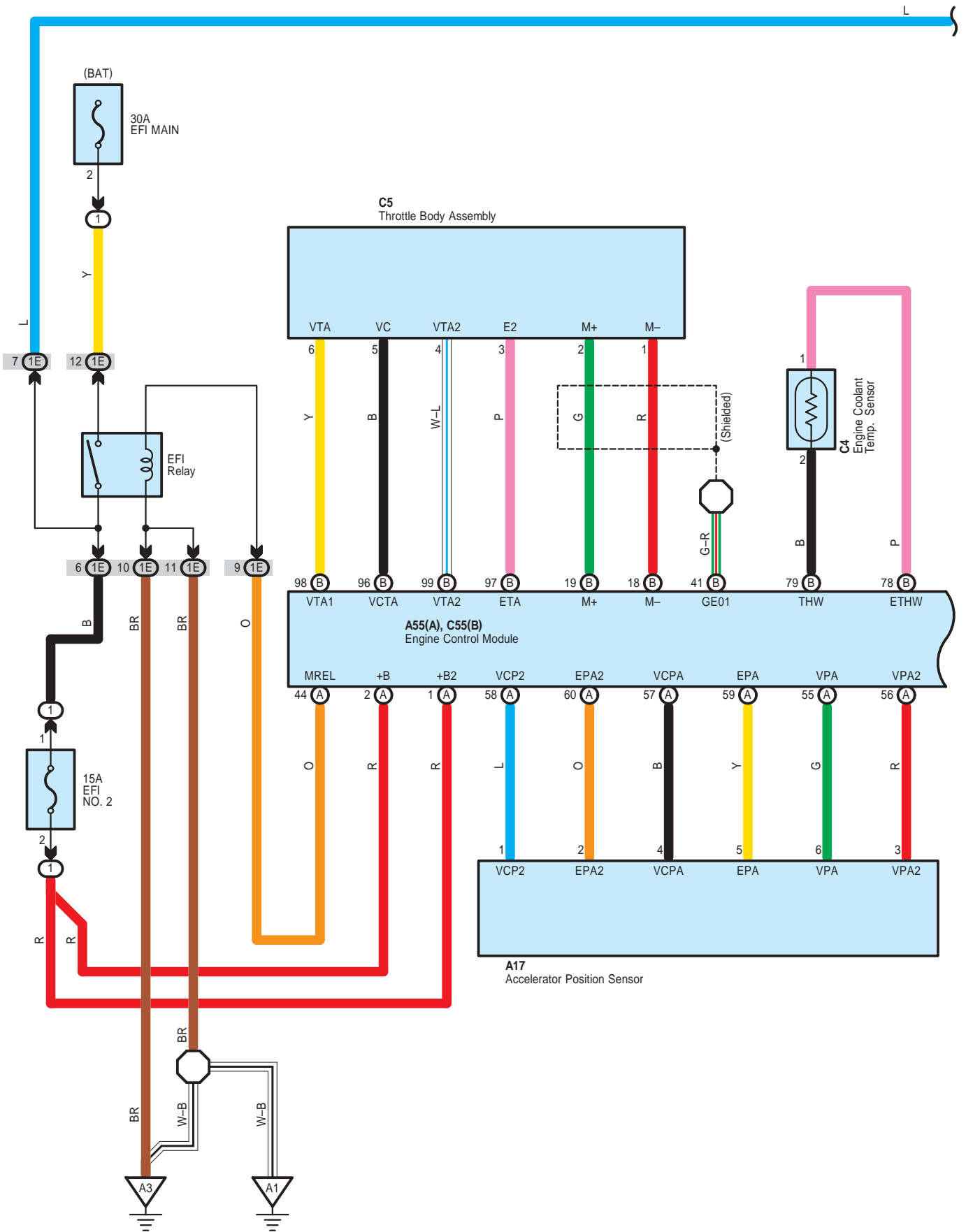

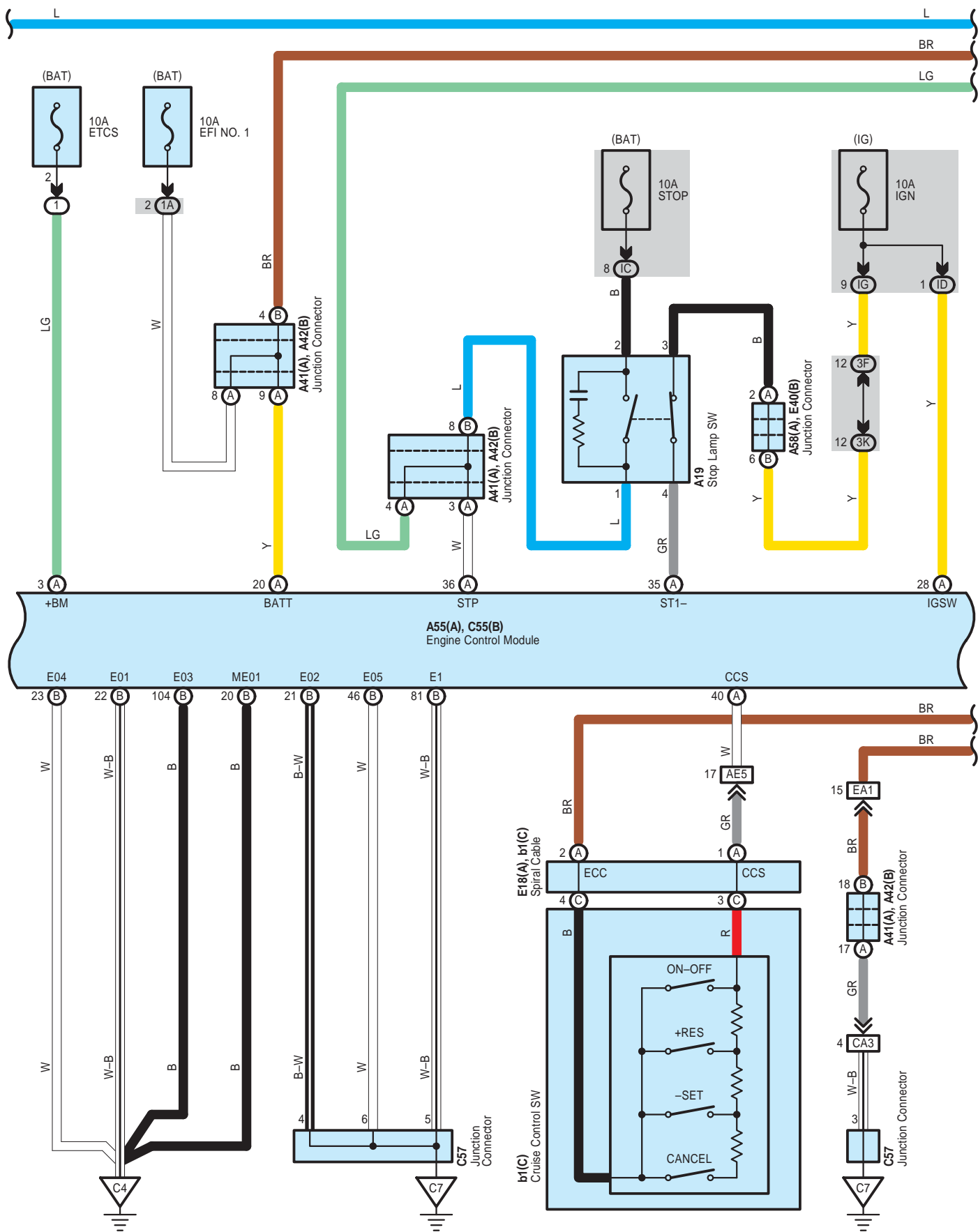

# Cruise Control for 2GR-FE

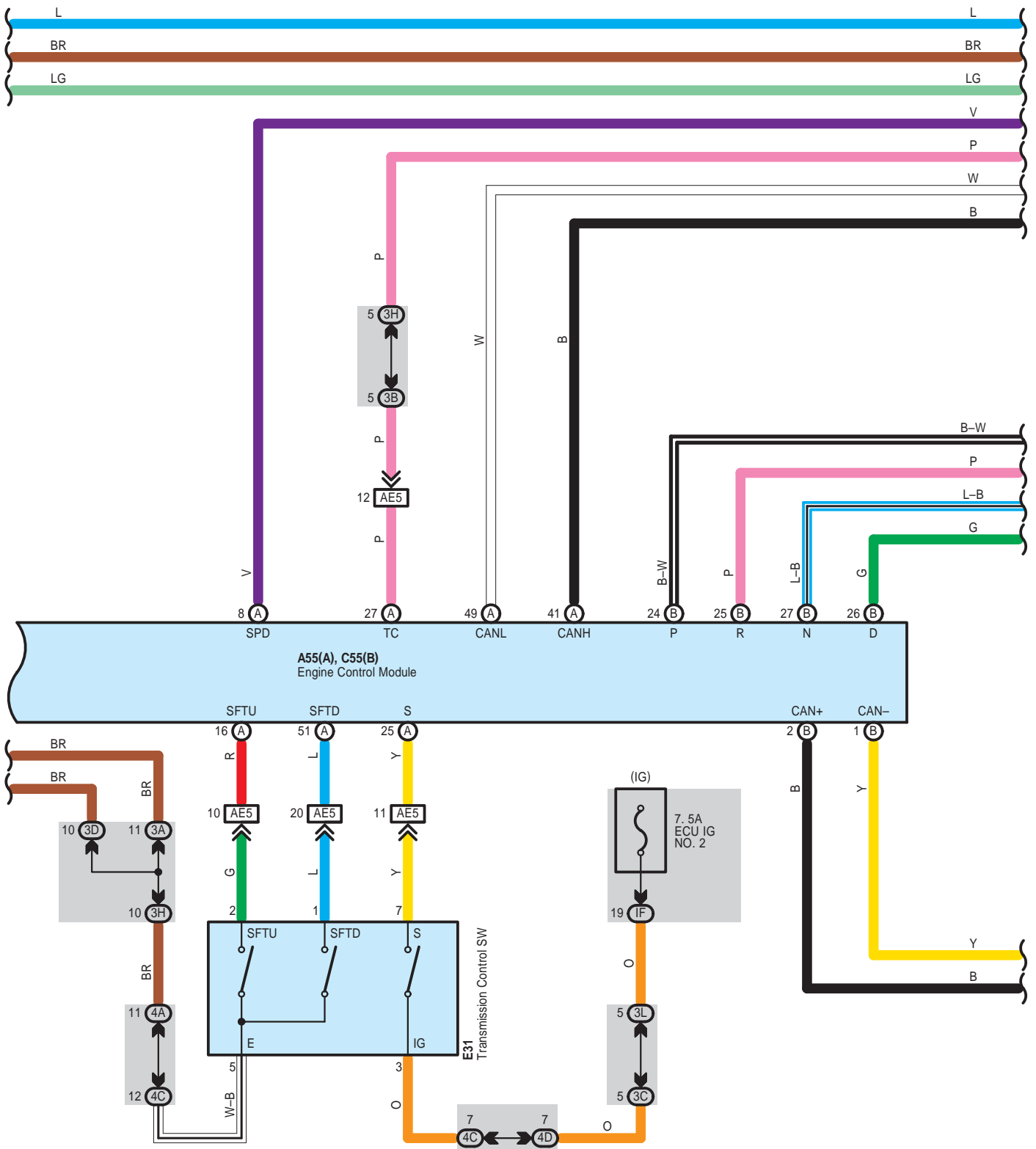

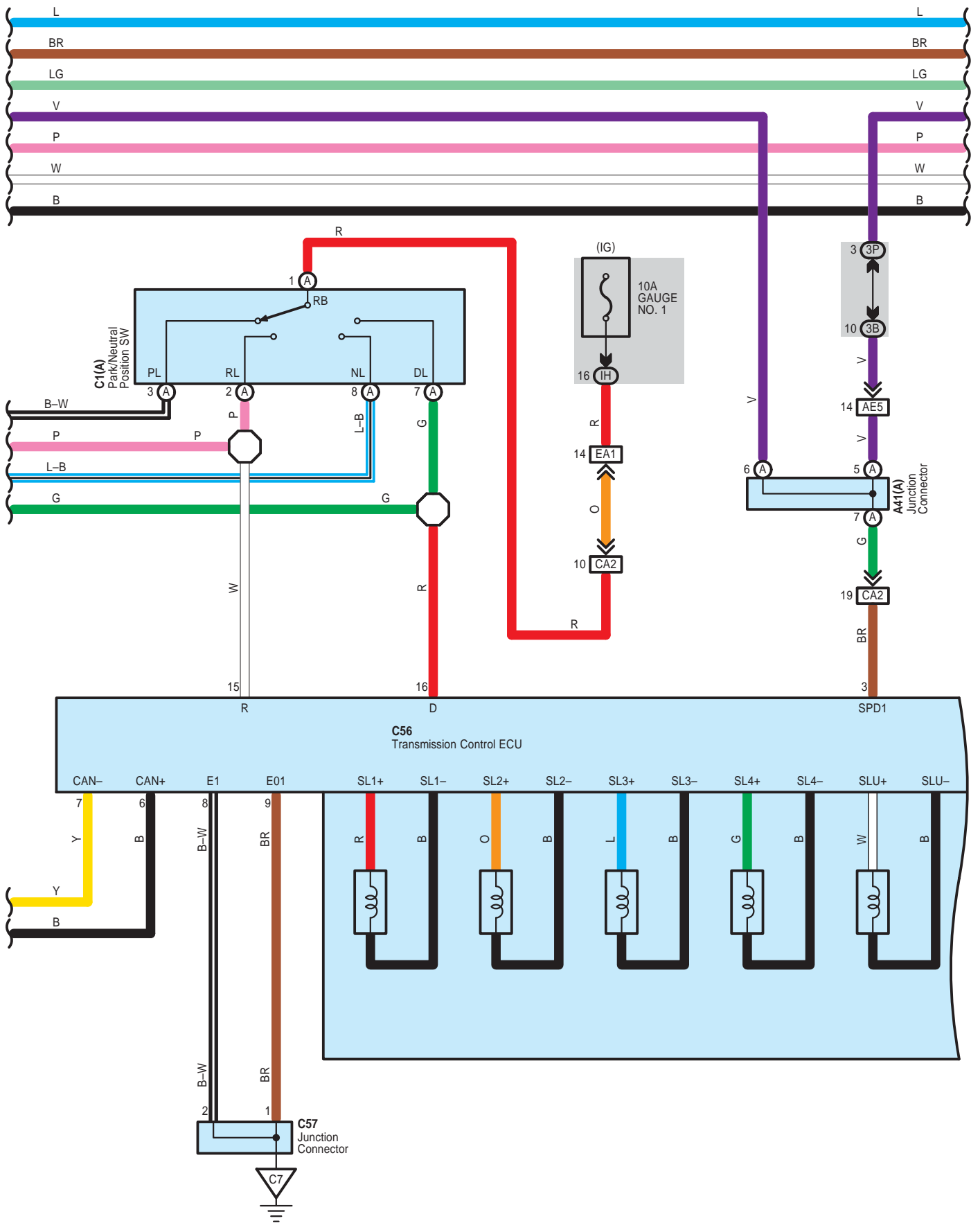

# Cruise Control for 2GR-FE

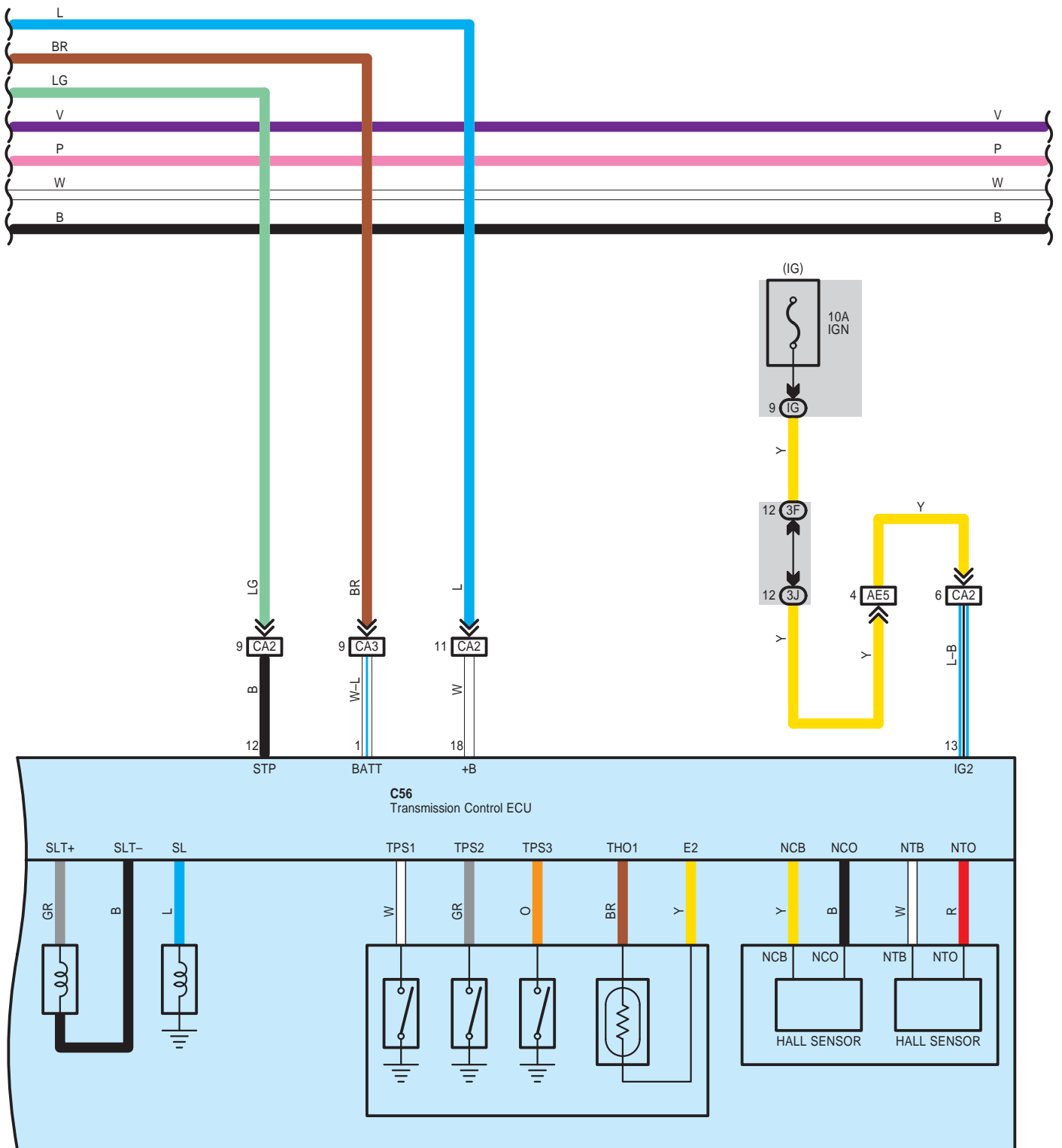

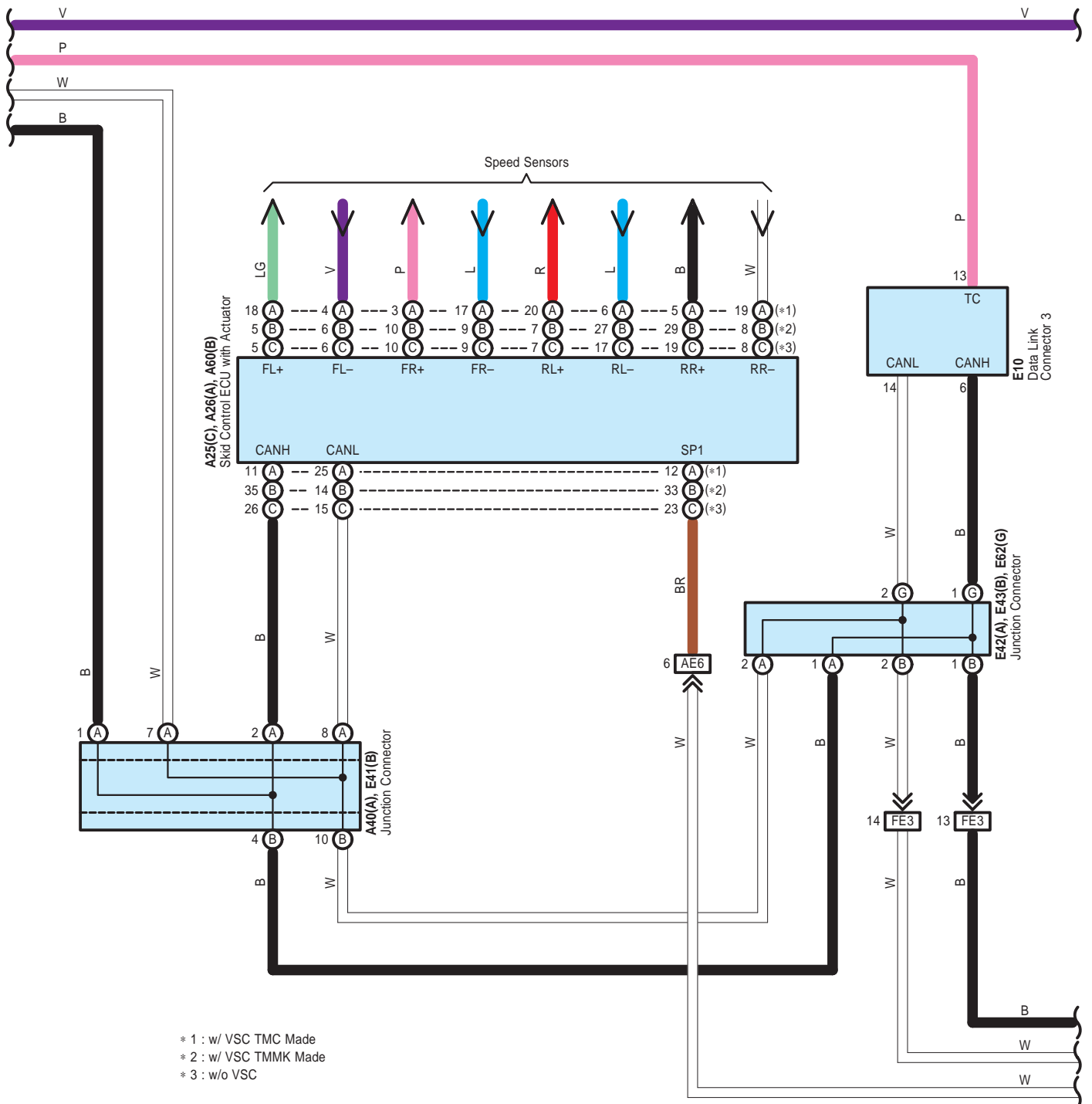



# Cruise Control for 2GR-FE

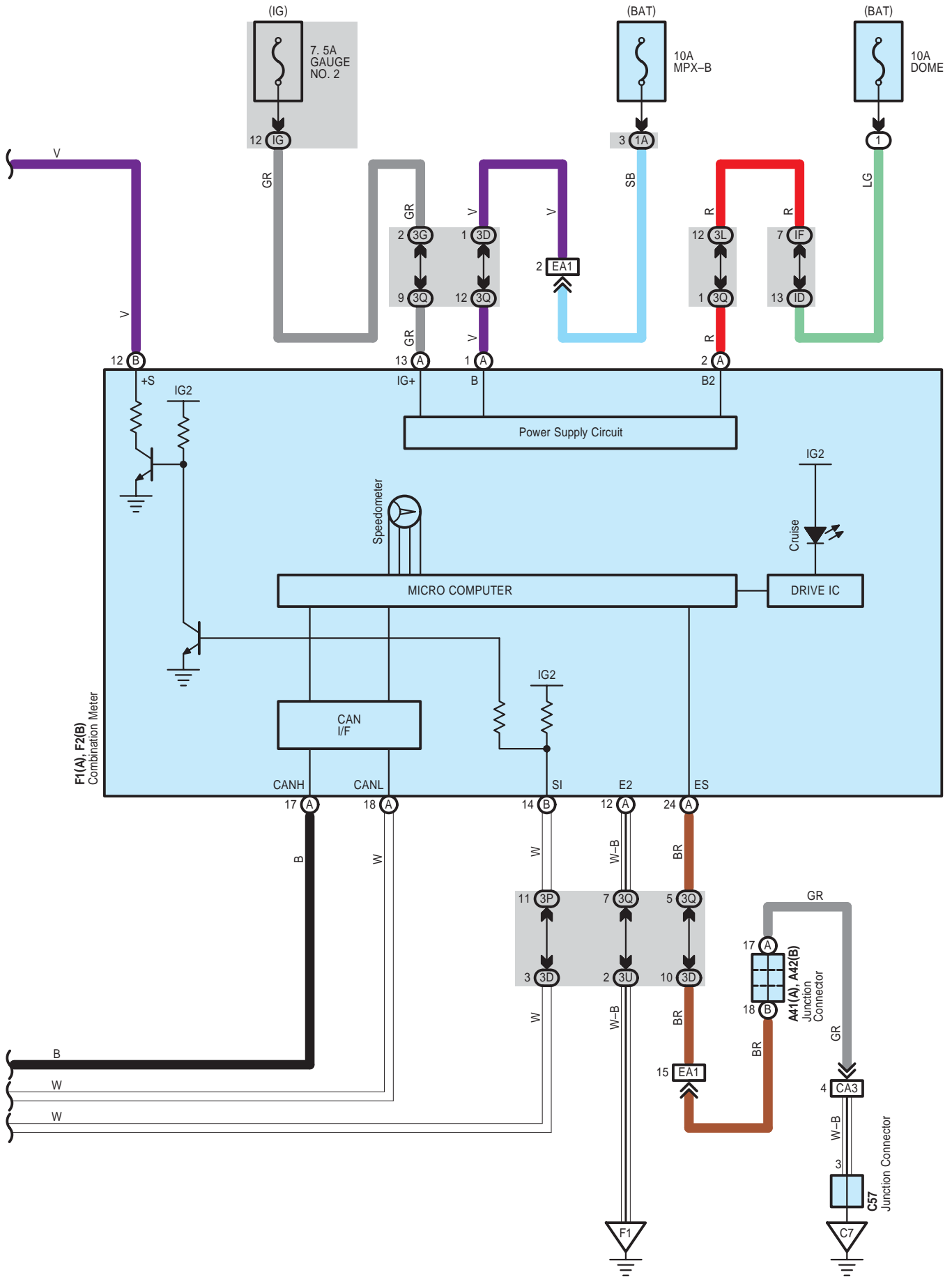

## System Outline

The cruise control system is a constant vehicle speed controller which controls the opening angle of the engine throttle valve by the SW, and allows driving at a constant speed without depressing the accelerator pedal.

### Set Operation

When the ON-OFF SW is turned on, the systems starts preparations for cruise control and turns on the indicator light in the combination meter.

### Set Speed Control

When the - SET SW is operated with the ON-OFF SW turned on during driving, the speed is controlled at a constant speed.

### Coast Control

When the - SET SW is kept turned on during cruise control driving, the engine control module controls the throttle valve to decelerate the vehicle speed.

Every time the - SET SW is turned on instantaneously, the vehicle speed is decelerated by approx. 1.6 km/h.

### Accel Control

When the + RES SW is kept turned on during cruise control driving, the engine control module controls the throttle valve to accelerate the vehicle speed.

Every time the + RES SW is turned on instantaneously, the vehicle speed is accelerated by approx. 1.6 km/h.

### Resume Control

If the vehicle speed is within the low speed limit (Approx. 40 km/h, 25 mph) when canceling the cruise control, operation of the + RES SW accelerates the vehicle speed and resumes the level before canceling the cruise control.

### Manual Cancel Mechanism

If any one of the following signals is input during cruise control driving, the cruise control is canceled.

- \* The stop light SW is on
- \* The CANCEL SW is turned on
- \* The ON-OFF SW is turned off
- \* When switching from ON to OFF of "D" position circuit in neutral start switch.  
When the transmission is shifted from "D" to "N".  
When the transmission is shifted from 5, 4 to 3, 2, 1 in S mode.

### Auto Cancel Function

If any of the following conditions are detected, the cruise control is canceled:

- \* Failure in the stop light SW wiring
- \* Abnormality in the vehicle speed signal
- \* Malfunction in the electronically controlled throttle parts
- \* When the vehicle speed gets slower than the low speed limit.
- \* When the vehicle speed falls to 16 km/h less than the set speed.

### Overdrive Function

The overdrive may be canceled if the vehicle travels on a upward slope during cruise control driving. When the throttle opening information indicates the hill climbing is finished after the overdrive is canceled, the vehicle returns to overdrive mode again as the overdrive return timer is completed.

## ○ : Parts Location

| Code | See Page      | Code | See Page      | Code | See Page |
|------|---------------|------|---------------|------|----------|
| A17  | 59            | A60  | B 49 (2GR-FE) | E31  | 56       |
| A19  | 59            | C1   | A 50 (2GR-FE) | E40  | B 57     |
| A25  | C 48 (2GR-FE) | C4   | 50 (2GR-FE)   | E41  | B 57     |
| A26  | A 48 (2GR-FE) | C5   | 50 (2GR-FE)   | E42  | A 57     |
| A40  | A 59          | C55  | B 51 (2GR-FE) | E43  | B 57     |
| A41  | A 59          | C56  | 51 (2GR-FE)   | E62  | G 57     |
| A42  | B 59          | C57  | 51 (2GR-FE)   | F1   | A 58     |
| A55  | A 49 (2GR-FE) | E10  | 56            | F2   | B 58     |
| A58  | A 59          | E18  | A 56          | b1   | C 59     |

## ○ : Relay Blocks

| Code | See Page | Relay Blocks (Relay Block Location)       |
|------|----------|---|
| 1    | 22       | Engine Room R/B (Engine Compartment Left) |

# Cruise Control for 2GR-FE

## : Junction Block and Wire Harness Connector

| Code | See Page | Junction Block and Wire Harness (Connector Location)                   |
|------|----------|--|
| 1A   | 25       | Engine Room Main Wire and Engine Room J/B (Engine Compartment Left)    |
| 1E   |          |  |
| 3A   | 36       | Instrument Panel Wire and J/B No.3 (Behind the Combination Meter)      |
| 3B   |          |  |
| 3C   |          |  |
| 3D   |          |  |
| 3F   |          |  |
| 3G   |          |  |
| 3H   |          |  |
| 3J   |          |  |
| 3K   |          |  |
| 3L   |          |  |
| 3P   | 36       | Instrument Panel No.2 Wire and J/B No.3 (Behind the Combination Meter) |
| 3Q   |          |  |
| 3U   |          |  |
| 4A   | 42       | Instrument Panel Wire and J/B No.4 (Instrument Panel Brace Center)     |
| 4C   |          |  |
| 4D   |          |  |
| IC   | 30       | Engine Room Main Wire and Instrument Panel J/B (Cowl Side Left)        |
| ID   |          |  |
| IF   | 30       | Instrument Panel Wire and Instrument Panel J/B (Cowl Side Left)        |
| IG   | 31       |  |
| IH   |          |  |

## : Connector Joining Wire Harness and Wire Harness

| Code | See Page    | Joining Wire Harness and Wire Harness (Connector Location)                                |
|------|-------------|---|
| AE5  | 66          | Engine Room Main Wire and Instrument Panel Wire (Instrument Panel Right)                  |
| AE6  |             |   |
| CA2  | 64 (2GR-FE) | Engine Wire and Engine Room Main Wire (Inside of the Engine Room R/B and Engine Room J/B) |
| CA3  |             |   |
| EA1  | 66          | Instrument Panel Wire and Engine Room Main Wire (Left Kick Panel)                         |
| FE3  | 66          | Instrument Panel No.2 Wire and Instrument Panel Wire (Instrument Panel Center)            |

## : Ground Points

| Code | See Page    | Ground Points Location          |
|------|-------------|---------------------------------|
| A1   | 64 (2GR-FE) | Front Left Fender               |
| A3   | 66          | Left Cowl Side Panel            |
| C4   | 64 (2GR-FE) | Cylinder Head                   |
| C7   | 64 (2GR-FE) | Left Side of the Cylinder Block |
| F1   | 66          | Instrument Panel Left           |



# Cruise Control for 2AZ-FE

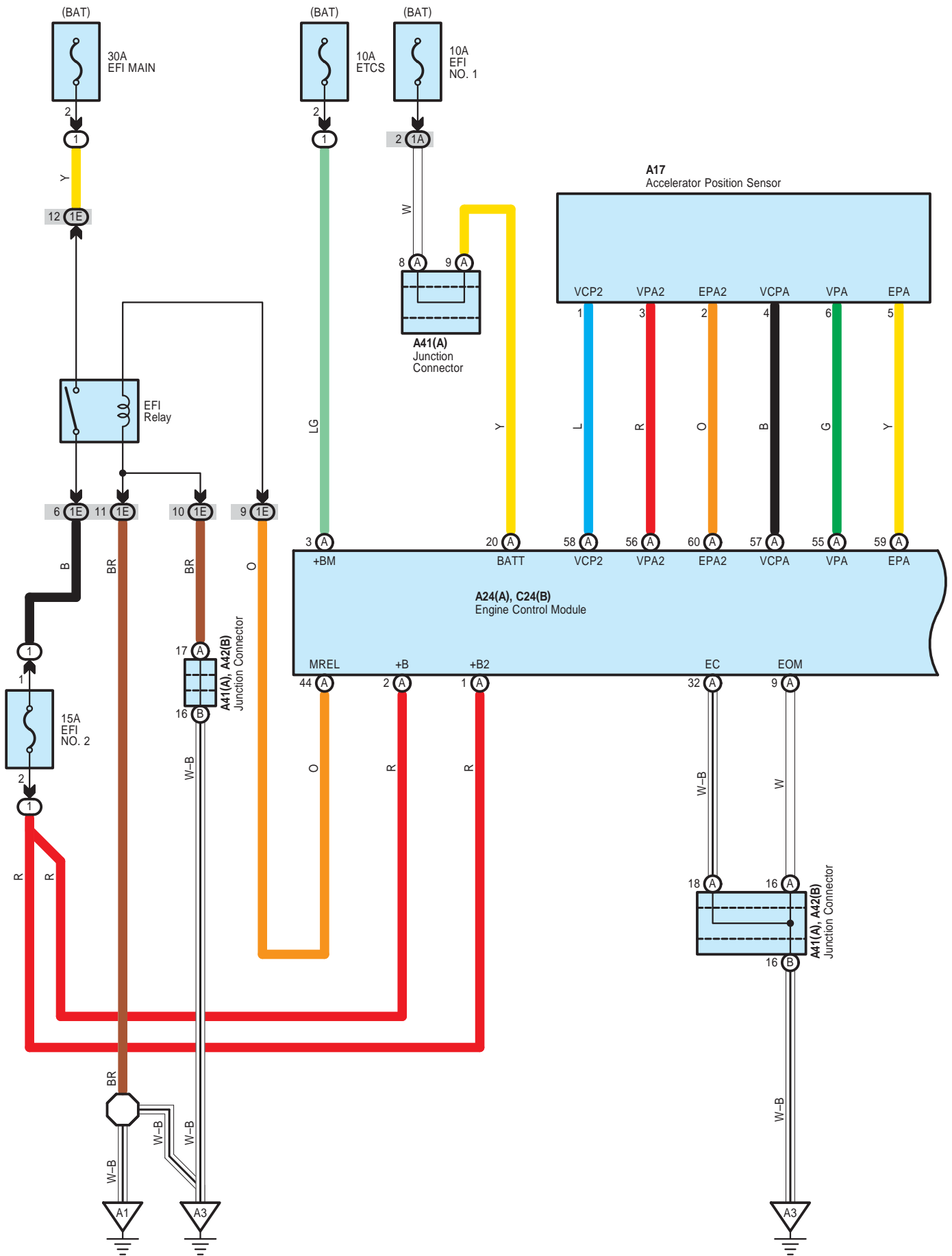

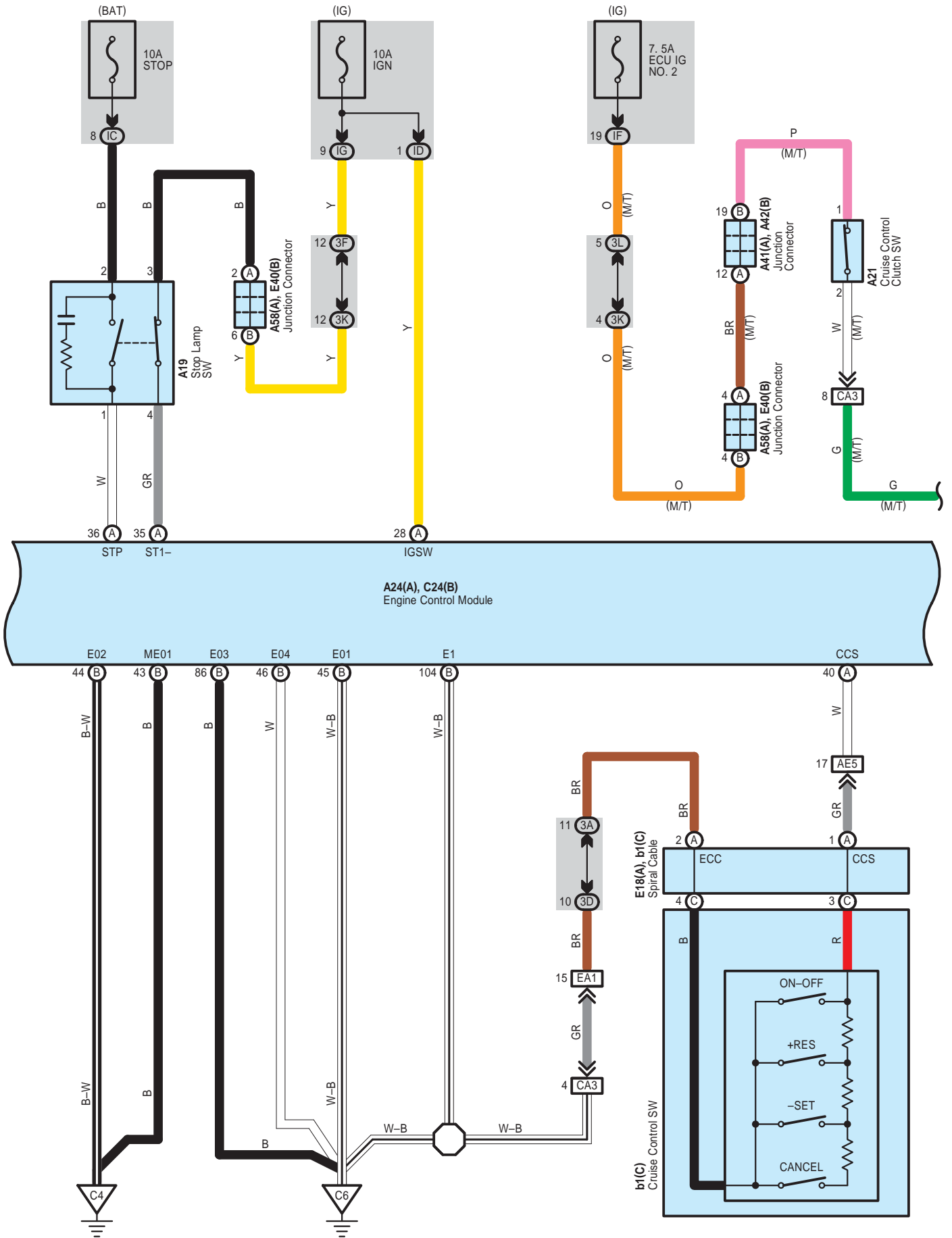

CAMRY (EM0250U)

# Cruise Control for 2AZ-FE

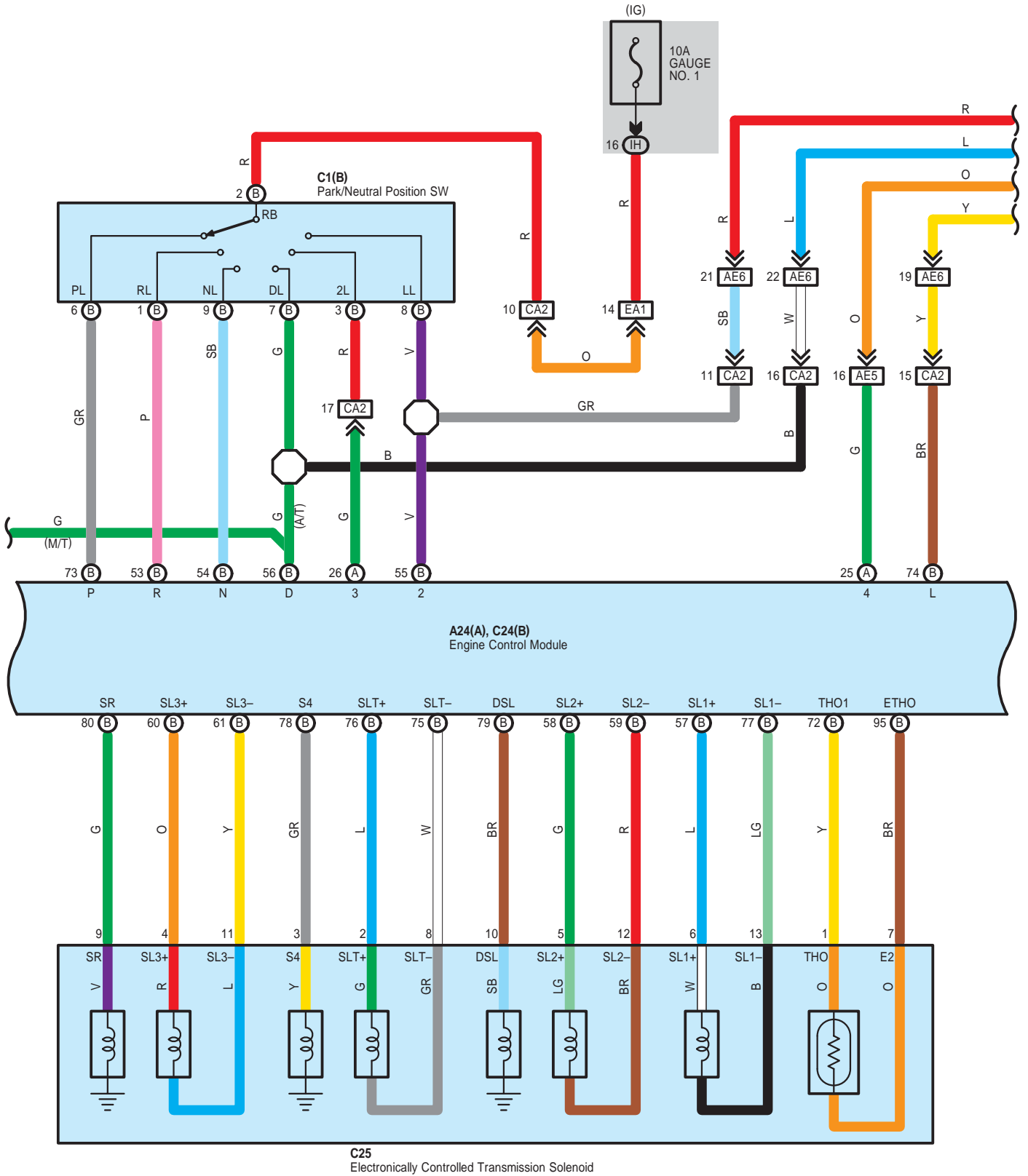

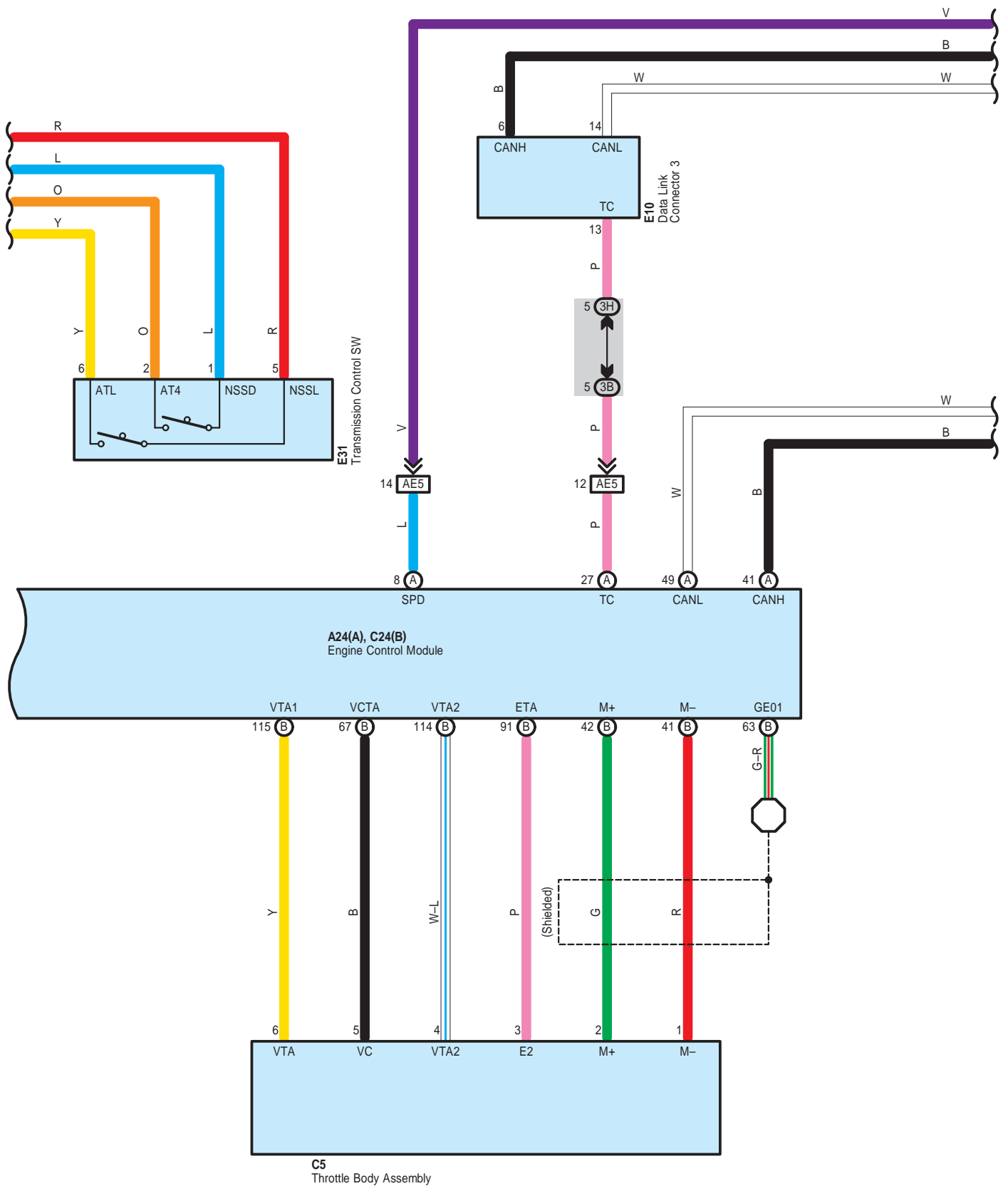



# Cruise Control for 2AZ-FE

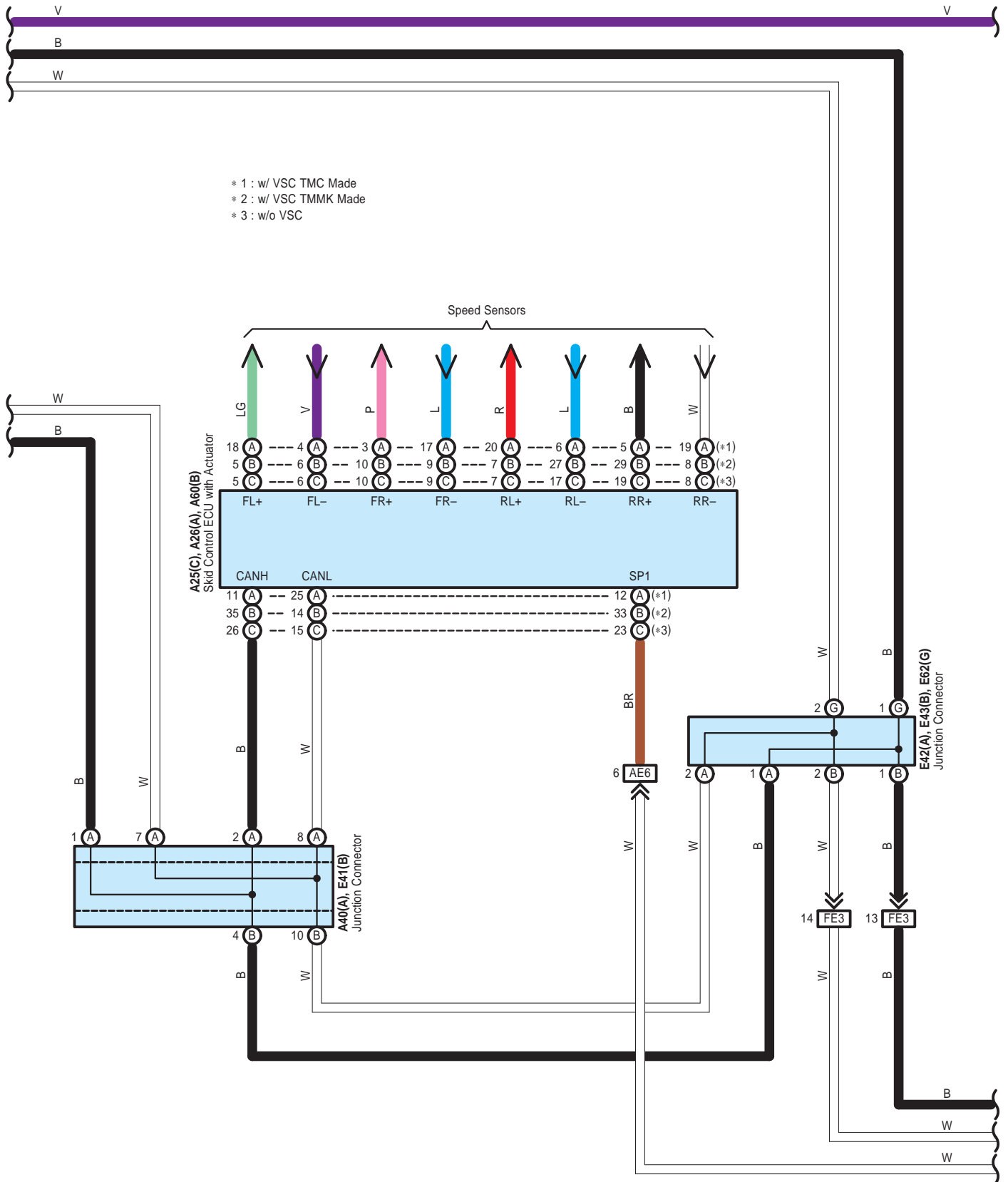

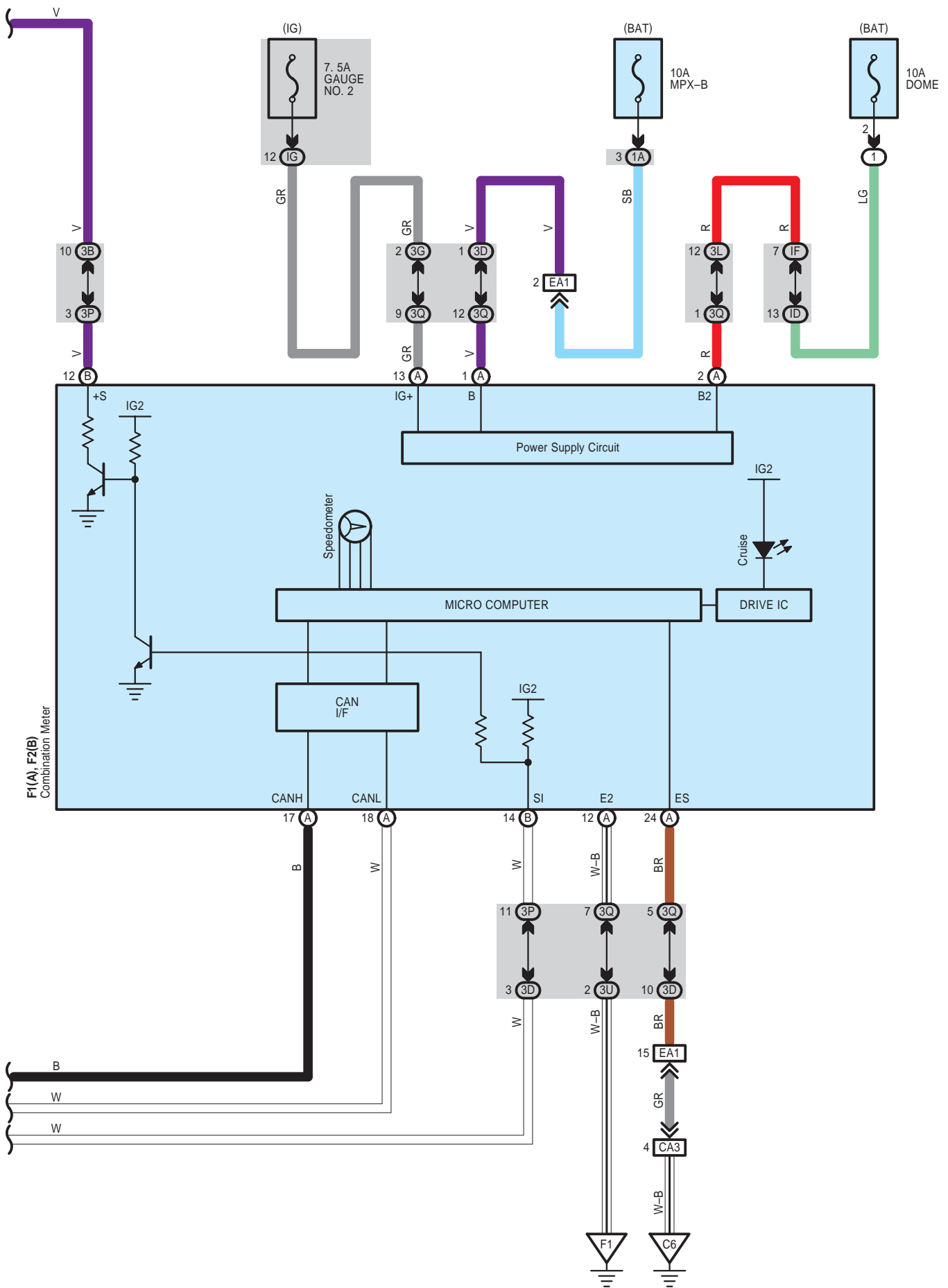

CAMRY (EM0250U)

# Cruise Control for 2AZ-FE

## System Outline

The cruise control system is a constant vehicle speed controller which controls the opening angle of the engine throttle valve by the SW, and allows driving at a constant speed without depressing the accelerator pedal.

### Set Operation

When the ON-OFF SW is turned on, the systems starts preparations for cruise control and turns on the indicator light in the combination meter.

### Set Speed Control

When the - SET SW is operated with the ON-OFF SW turned on during driving, the speed is controlled at a constant speed.

### Coast Control

When the - SET SW is kept turned on during cruise control driving, the engine control module controls the throttle valve to decelerate the vehicle speed.

Every time the - SET SW is turned on instantaneously, the vehicle speed is decelerated by approx. 1.6 km/h.

### Accel Control

When the + RES SW is kept turned on during cruise control driving, the engine control module controls the throttle valve to accelerate the vehicle speed.

Every time the + RES SW is turned on instantaneously, the vehicle speed is accelerated by approx. 1.6 km/h.

### Resume Control

If the vehicle speed is within the low speed limit (Approx. 40 km/h, 25 mph) when canceling the cruise control, operation of the + RES SW accelerates the vehicle speed and resumes the level before canceling the cruise control.

### Manual Cancel Mechanism

If any one of the following signals is input during cruise control driving, the cruise control is canceled.

- \* The stop light SW is on
- \* The CANCEL SW is turned on
- \* The ON-OFF SW is turned off
- \* Gear is shifted D position to other positions than D. (A/T)
- \* The clutch pedal is depressed. (M/T)

### Auto Cancel Function

If any of the following conditions are detected, the cruise control is canceled:

- \* Failure in the stop light SW wiring
- \* Abnormality in the vehicle speed signal
- \* Malfunction in the electronically controlled throttle parts
- \* When the vehicle speed gets slower than the low speed limit.
- \* When the vehicle speed falls to 16 km/h less than the set speed.

### Overdrive Function

The overdrive may be canceled if the vehicle travels on a upward slope during cruise control driving. When the throttle opening information indicates the hill climbing is finished after the overdrive is canceled, the vehicle returns to overdrive mode again as the overdrive return timer is completed.

## ○ : Parts Location

| Code | See Page      | Code | See Page      | Code | See Page |
|------|---------------|------|---------------|------|----------|
| A17  | 59            | A58  | A 59          | E40  | B 57     |
| A19  | 59            | A60  | B 53 (2AZ-FE) | E41  | B 57     |
| A21  | 59            | C1   | B 54 (2AZ-FE) | E42  | A 57     |
| A24  | A 52 (2AZ-FE) | C5   | 54 (2AZ-FE)   | E43  | B 57     |
| A25  | C 52 (2AZ-FE) | C24  | B 55 (2AZ-FE) | E62  | G 57     |
| A26  | A 52 (2AZ-FE) | C25  | 55 (2AZ-FE)   | F1   | A 58     |
| A40  | A 59          | E10  | 56            | F2   | B 58     |
| A41  | A 59          | E18  | A 56          | b1   | C 59     |
| A42  | B 59          | E31  | 56            |      |          |

## ○ : Relay Blocks

| Code | See Page | Relay Blocks (Relay Block Location)       |
|------|----------|---|
| 1    | 22       | Engine Room R/B (Engine Compartment Left) |

 : Junction Block and Wire Harness Connector

| Code | See Page | Junction Block and Wire Harness (Connector Location)                   |
|------|----------|--|
| 1A   | 25       | Engine Room Main Wire and Engine Room J/B (Engine Compartment Left)    |
| 1E   |          |  |
| 3A   | 36       | Instrument Panel Wire and J/B No.3 (Behind the Combination Meter)      |
| 3B   |          |  |
| 3D   |          |  |
| 3F   |          |  |
| 3G   |          |  |
| 3H   |          |  |
| 3K   |          |  |
| 3L   |          |  |
| 3P   | 36       | Instrument Panel No.2 Wire and J/B No.3 (Behind the Combination Meter) |
| 3Q   |          |  |
| 3U   |          |  |
| IC   | 30       | Engine Room Main Wire and Instrument Panel J/B (Cowl Side Left)        |
| ID   |          |  |
| IF   | 30       | Instrument Panel Wire and Instrument Panel J/B (Cowl Side Left)        |
| IG   | 31       |  |
| IH   |          |  |

 : Connector Joining Wire Harness and Wire Harness

| Code | See Page    | Joining Wire Harness and Wire Harness (Connector Location)                                |
|------|-------------|---|
| AE5  | 66          | Engine Room Main Wire and Instrument Panel Wire (Instrument Panel Right)                  |
| AE6  |             |   |
| CA2  | 65 (2AZ-FE) | Engine Wire and Engine Room Main Wire (Inside of the Engine Room R/B and Engine Room J/B) |
| CA3  |             |   |
| EA1  | 66          | Instrument Panel Wire and Engine Room Main Wire (Left Kick Panel)                         |
| FE3  | 66          | Instrument Panel No.2 Wire and Instrument Panel Wire (Instrument Panel Center)            |

 : Ground Points

| Code | See Page    | Ground Points Location |
|------|-------------|------------------------|
| A1   | 65 (2AZ-FE) | Front Left Fender      |
| A3   | 66          | Left Cowl Side Panel   |
| C4   | 65 (2AZ-FE) | Cylinder Block         |
| C6   |             |                        |
| F1   | 66          | Instrument Panel Left  |



E6(A), E7(B), E9(D)  
Main Body ECU

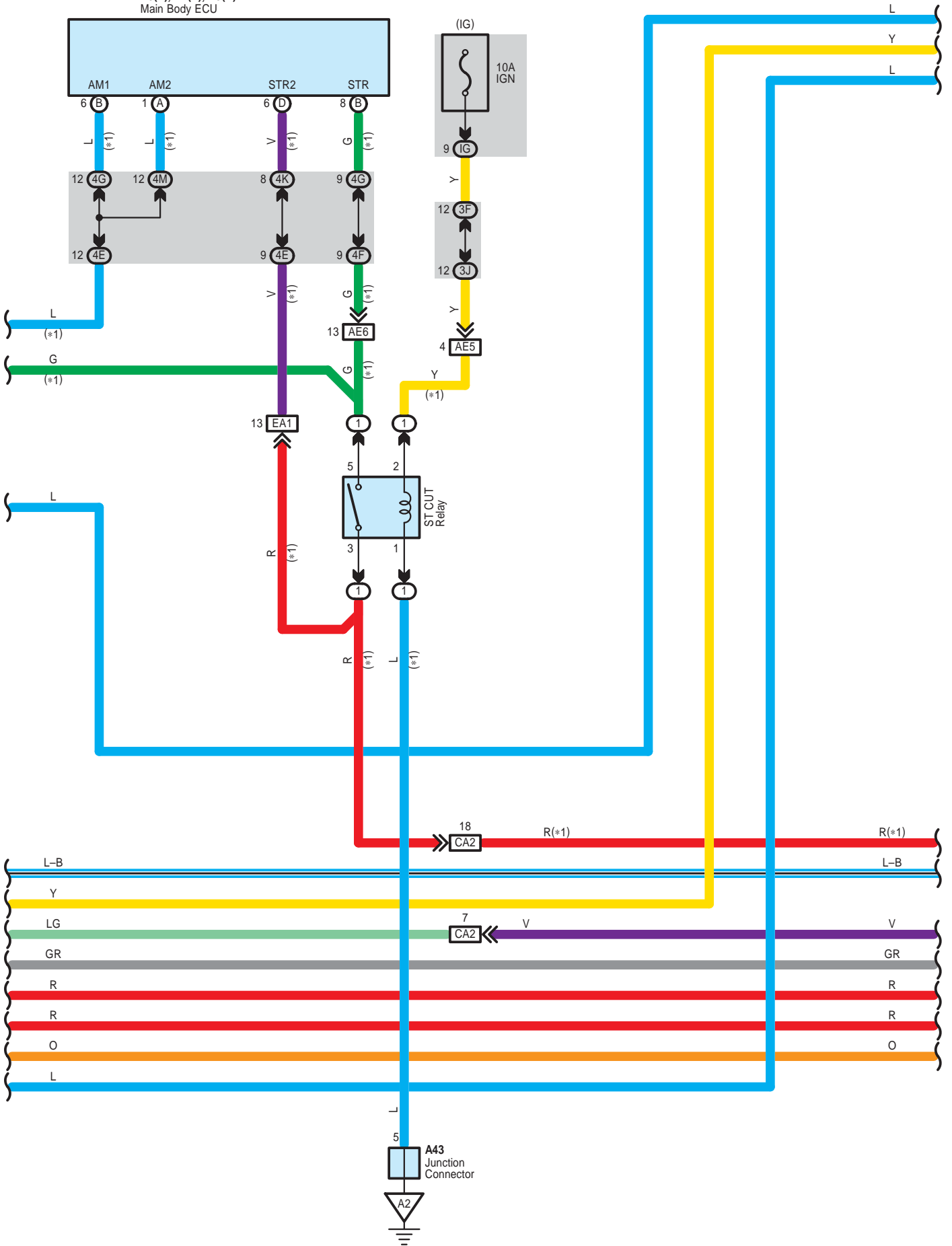

CAMRY (EM0250U)

# ECT and A/T Indicator for 2GR-FE



\* 1 : w/ Smart Key System

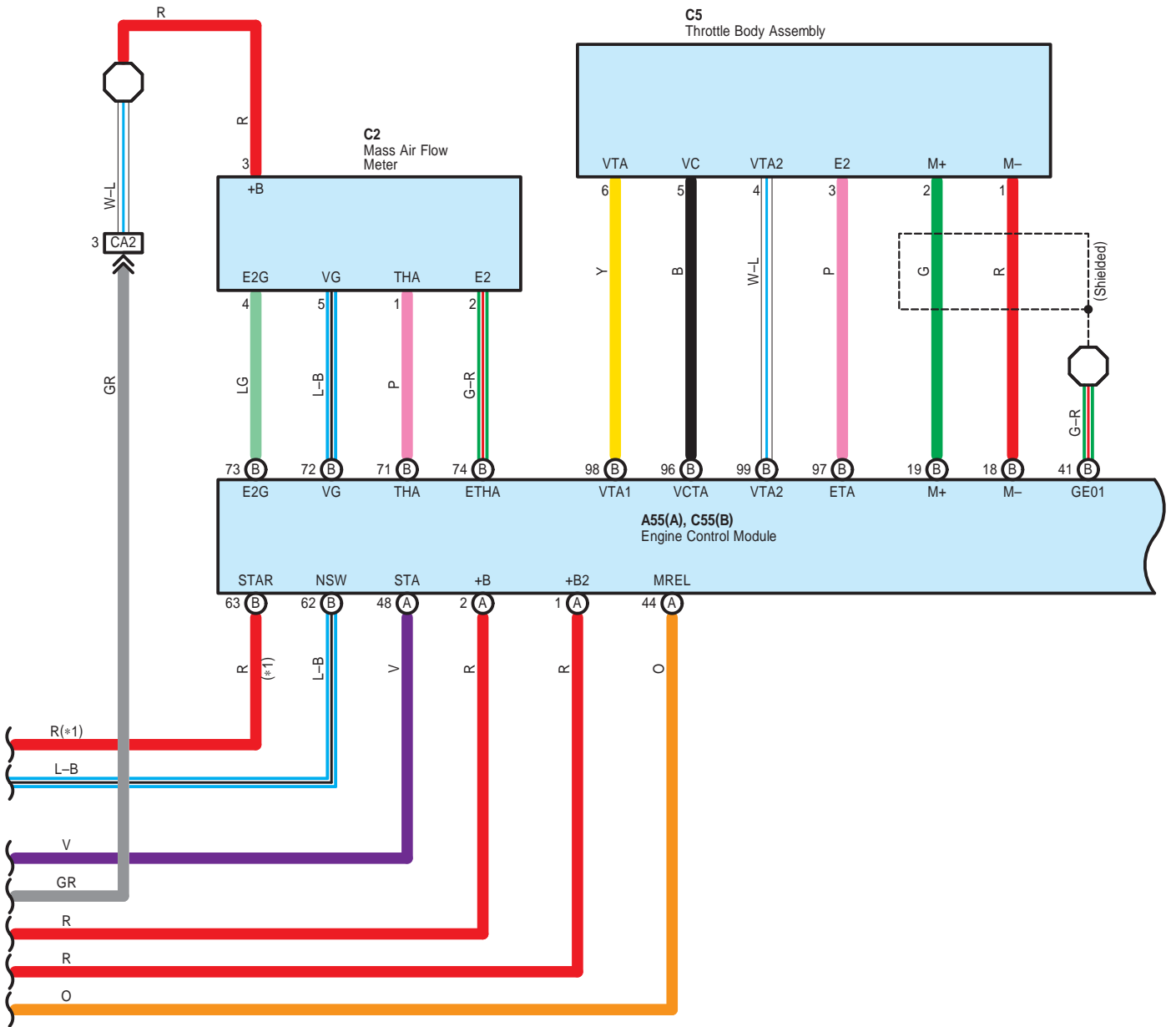

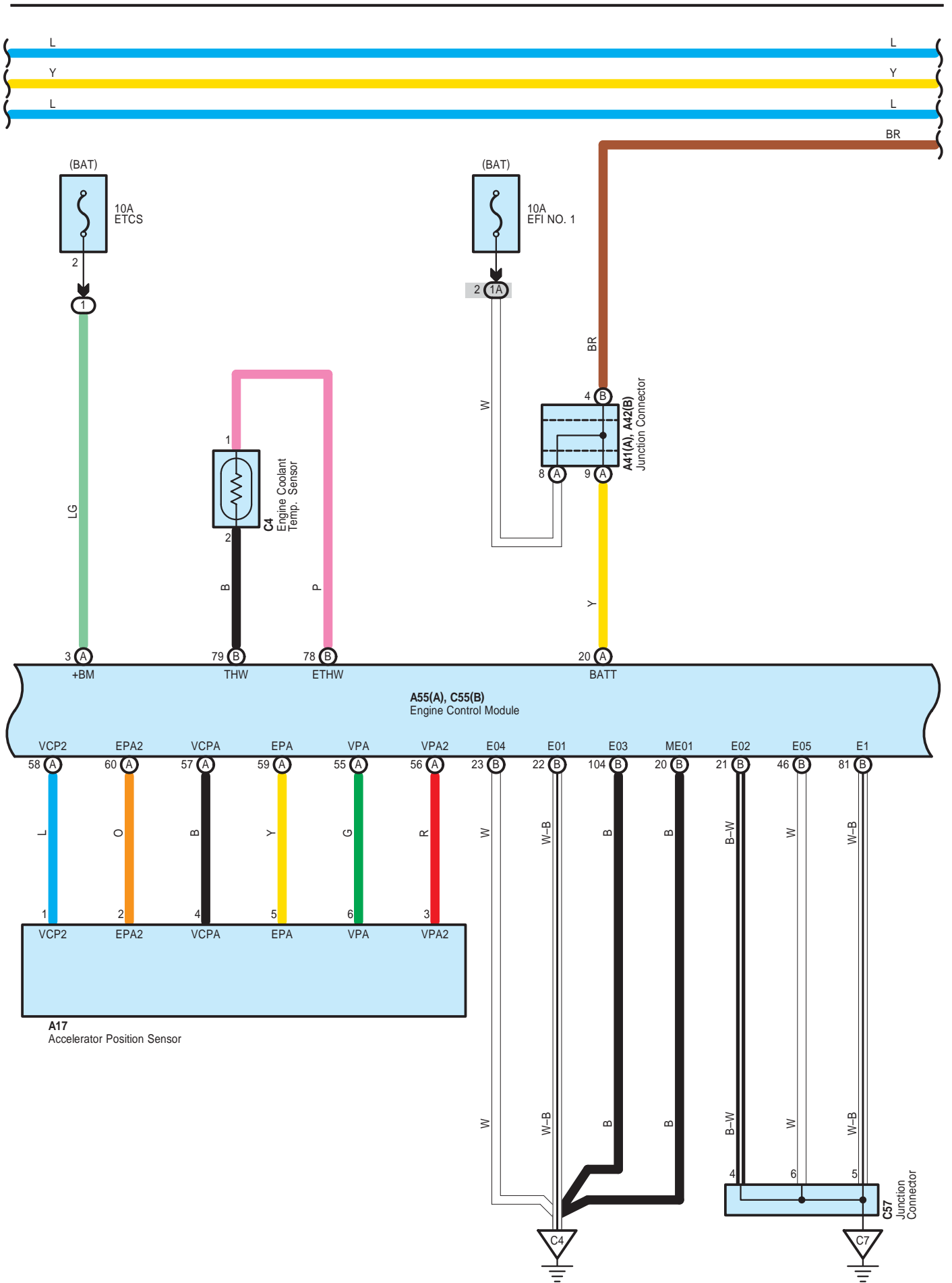



# ECT and A/T Indicator for 2GR-FE

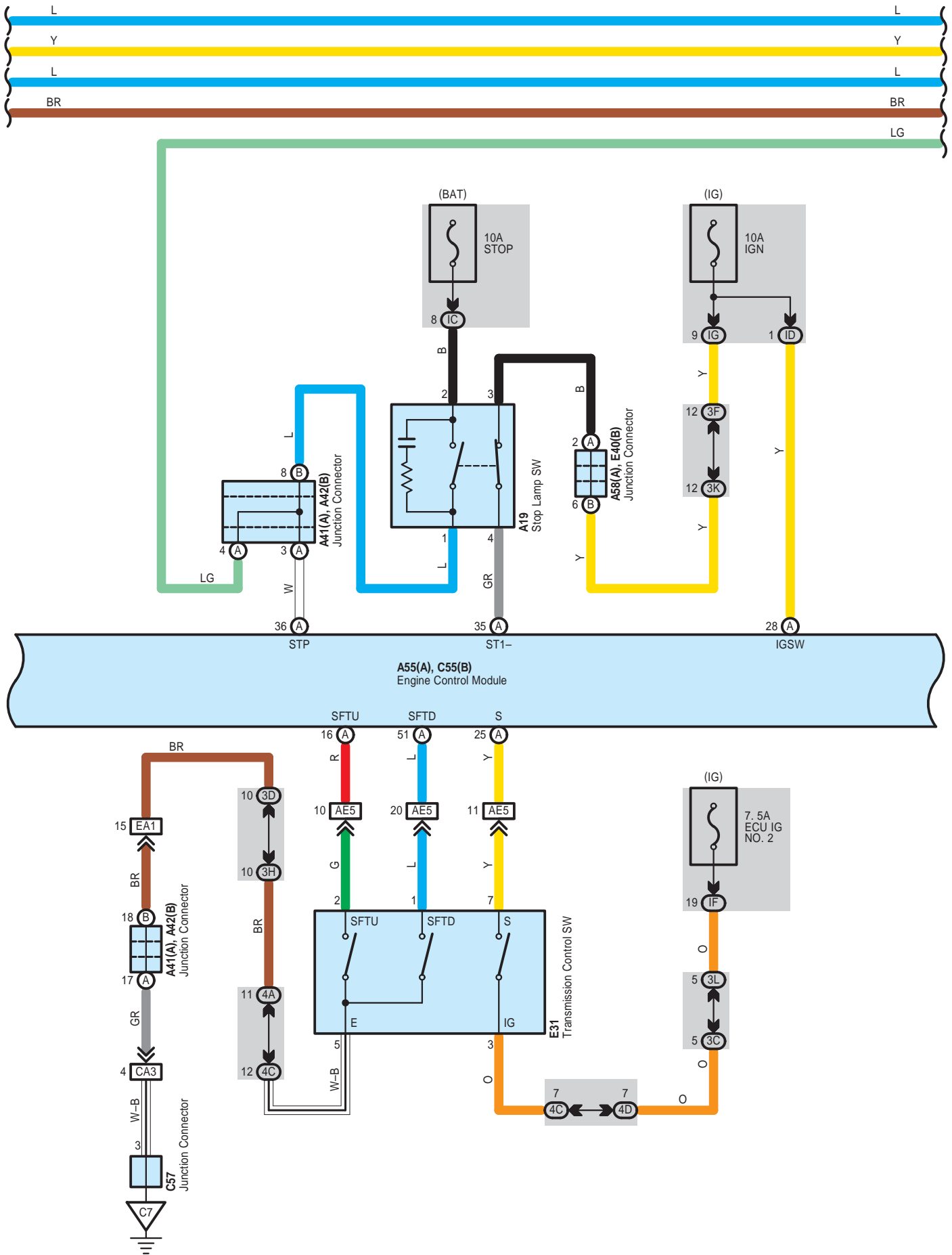

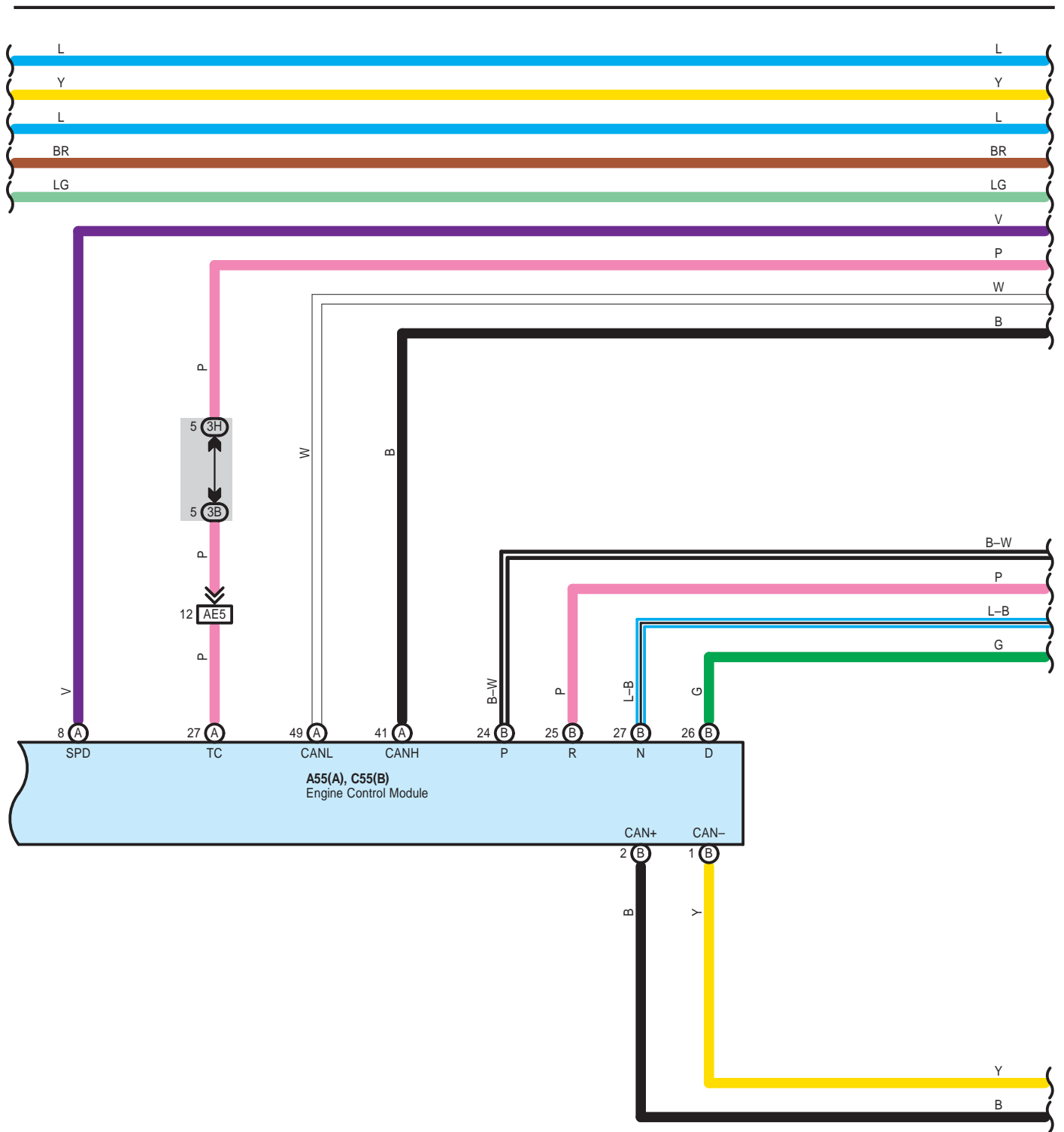

# ECT and A/T Indicator for 2GR-FE

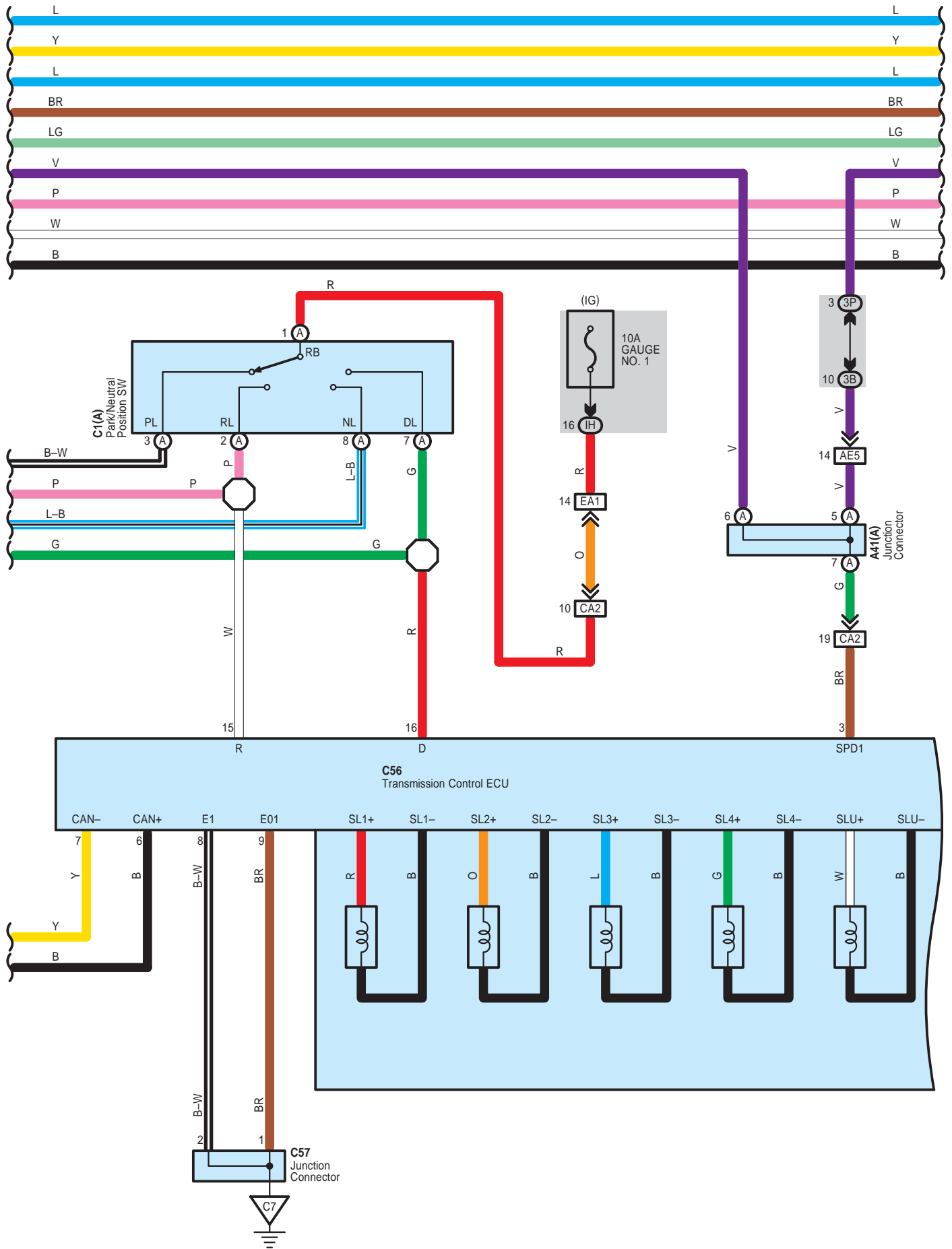

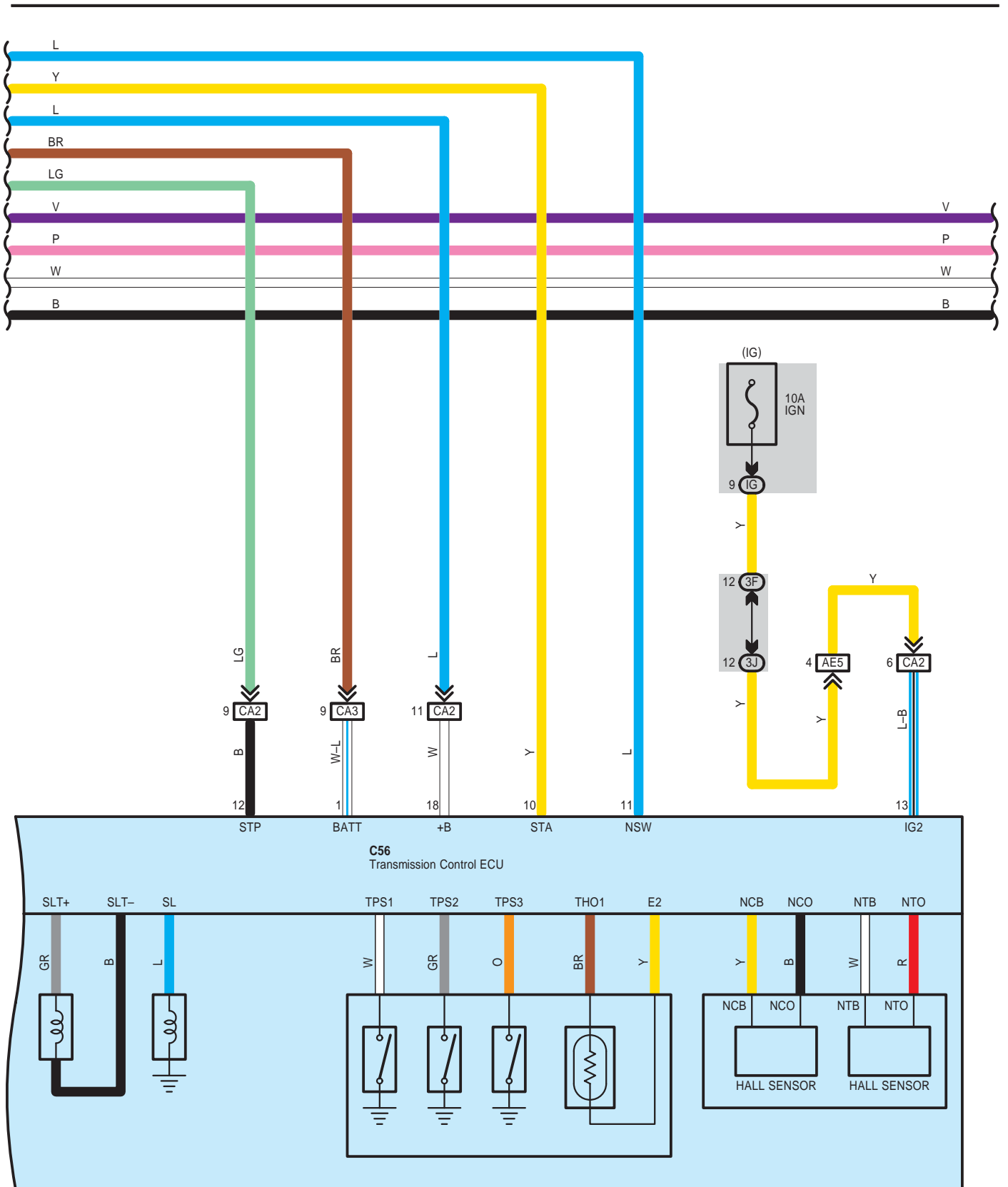

# ECT and A/T Indicator for 2GR-FE

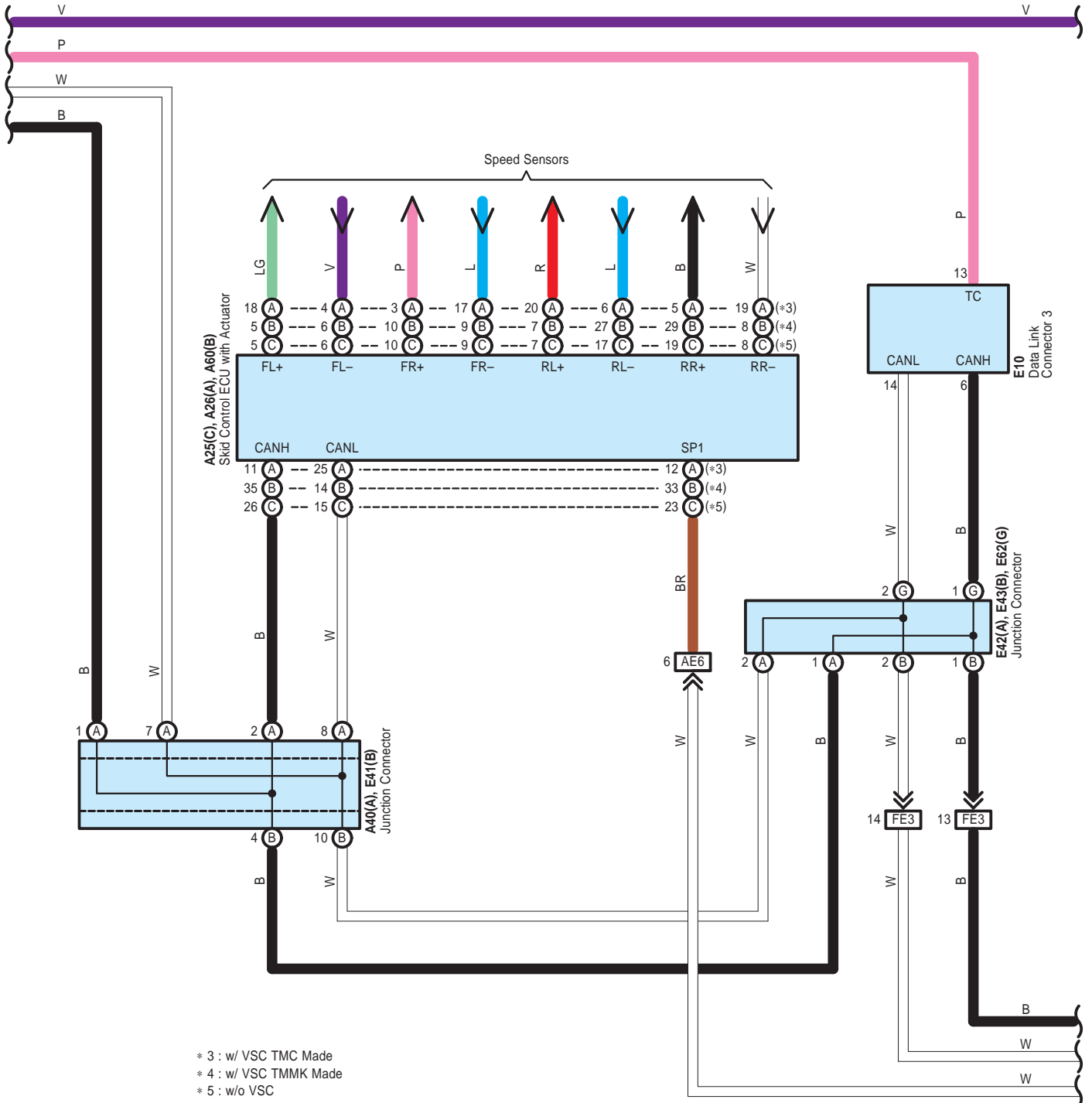

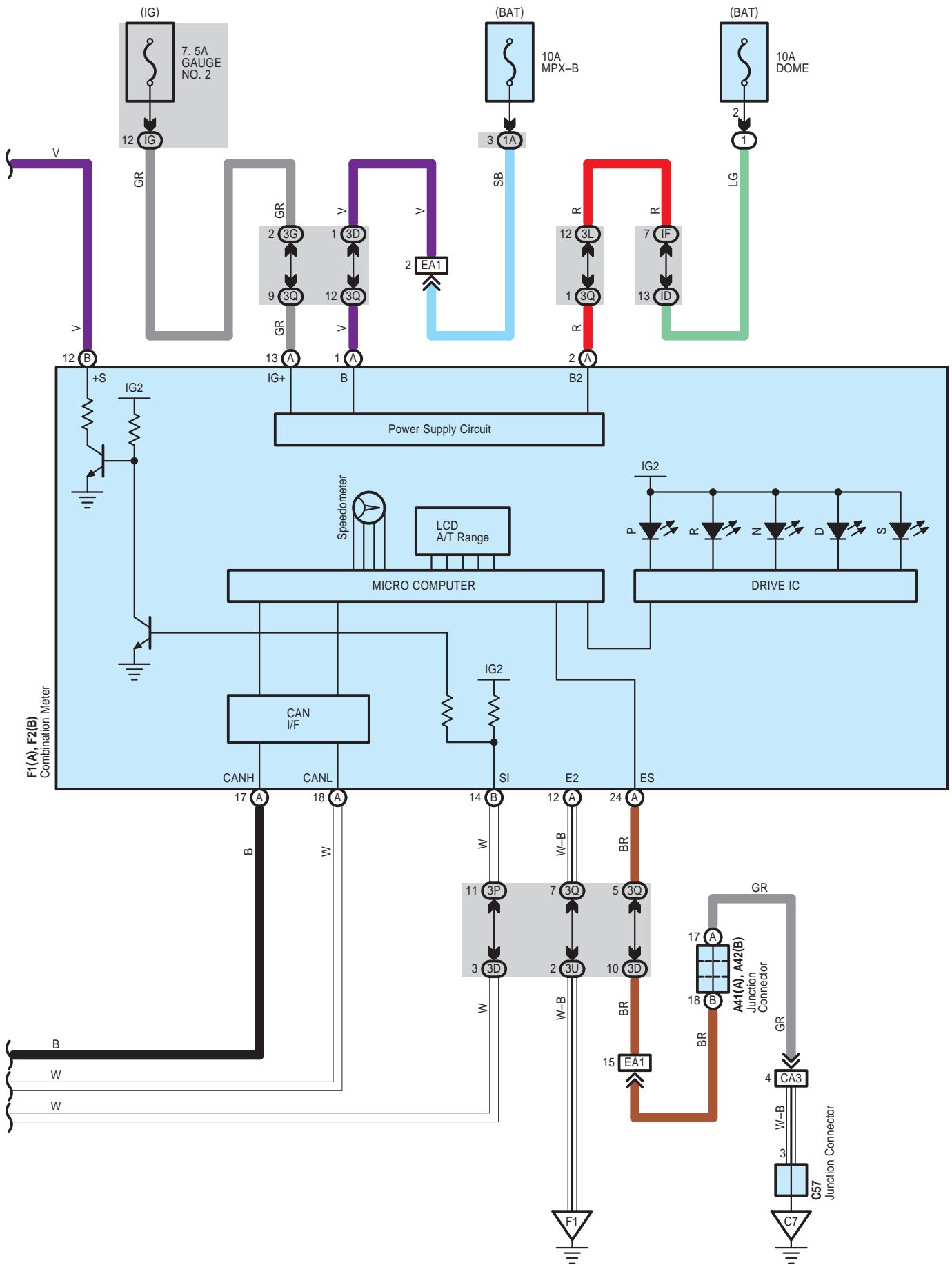

# ECT and A/T Indicator for 2GR-FE

## System Outline

### 1. Line Pressure Optimal Control

Through the use of the solenoid valve SLT, the line pressure is optimally controlled in accordance with the engine torque information, as well as with the internal operating conditions of the torque converter and the transaxle. Accordingly, the line pressure can be controlled minutely in accordance with the engine output, traveling condition, and the ATF temperature, thus realizing smooth shift characteristics and optimizing the workload in the oil pump.

### 2. Clutch Pressure Optimal Control

The engine control module monitors the signals from various types of sensor such as the input turbine speed sensor, allowing shift solenoid valves SL1, SL2 and SL3 to minutely control the clutch pressure in accordance with engine output and driving conditions. As a result, smooth shift characteristics have been realized.

### 3. Shifting Control in Uphill/Downhill Traveling

This control minimizes the shifting of gears when the driver operates the accelerator pedal while driving on a winding road with ups and downs, in order to ensure a smooth drive.

### 4. Flex Lock-Up Clutch Control

The flex lock-up clutch control operates during acceleration, in the 4th and 5th gear in the D range, and during deceleration, in the 4th and 5th gear in the D range and in the 4th gear in the 4 range.

### 5. Multi Mode Automatic Transmission

Multi mode automatic transmission have [S]-position is beside of [D]-position. If moving the selector lever "S" side, you can select shift range just link manual shifting.

## ○ : Parts Location

| Code    | See Page    | Code    | See Page    | Code    | See Page |
|---------|-------------|---------|-------------|---------|----------|
| A17     | 59          | C1   A  | 50 (2GR-FE) | E23     | 56       |
| A19     | 59          | C2      | 50 (2GR-FE) | E31     | 56       |
| A25   C | 48 (2GR-FE) | C4      | 50 (2GR-FE) | E40   B | 57       |
| A26   A | 48 (2GR-FE) | C5      | 50 (2GR-FE) | E41   B | 57       |
| A40   A | 59          | C55   B | 51 (2GR-FE) | E42   A | 57       |
| A41   A | 59          | C56     | 51 (2GR-FE) | E43   B | 57       |
| A42   B | 59          | C57     | 51 (2GR-FE) | E62   G | 57       |
| A43     | 49 (2GR-FE) | E6   A  | 56          | F1   A  | 58       |
| A55   A | 49 (2GR-FE) | E7   B  | 56          | F2   B  | 58       |
| A58   A | 59          | E9   D  | 56          |         |          |
| A60   B | 49 (2GR-FE) | E10     | 56          |         |          |

## ○ : Relay Blocks

| Code | See Page | Relay Blocks (Relay Block Location)       |
|------|----------|---|
| 1    | 22       | Engine Room R/B (Engine Compartment Left) |

 : Junction Block and Wire Harness Connector

| Code | See Page | Junction Block and Wire Harness (Connector Location)                   |
|------|----------|--|
| 1A   | 25       | Engine Room Main Wire and Engine Room J/B (Engine Compartment Left)    |
| 1E   |          |  |
| 3B   | 36       | Instrument Panel Wire and J/B No.3 (Behind the Combination Meter)      |
| 3C   |          |  |
| 3D   |          |  |
| 3E   |          |  |
| 3F   |          |  |
| 3G   |          |  |
| 3H   |          |  |
| 3J   |          |  |
| 3K   |          |  |
| 3L   |          |  |
| 3P   | 36       | Instrument Panel No.2 Wire and J/B No.3 (Behind the Combination Meter) |
| 3Q   |          |  |
| 3U   |          |  |
| 4A   | 42       | Instrument Panel Wire and J/B No.4 (Instrument Panel Brace Center)     |
| 4C   |          |  |
| 4D   |          |  |
| 4E   |          |  |
| 4F   |          |  |
| 4G   |          |  |
| 4K   |          |  |
| 4M   |          |  |
| IC   | 30       | Engine Room Main Wire and Instrument Panel J/B (Cowl Side Left)        |
| ID   | 30       | Instrument Panel Wire and Instrument Panel J/B (Cowl Side Left)        |
| IF   | 30       |  |
| IG   | 31       |  |
| IH   |          |  |
| II   |          |  |

 : Connector Joining Wire Harness and Wire Harness

| Code | See Page    | Joining Wire Harness and Wire Harness (Connector Location)                                |
|------|-------------|---|
| AE5  | 66          | Engine Room Main Wire and Instrument Panel Wire (Instrument Panel Right)                  |
| AE6  |             |   |
| CA2  | 64 (2GR-FE) | Engine Wire and Engine Room Main Wire (Inside of the Engine Room R/B and Engine Room J/B) |
| CA3  |             |   |
| EA1  | 66          | Instrument Panel Wire and Engine Room Main Wire (Left Kick Panel)                         |
| FE3  | 66          | Instrument Panel No.2 Wire and Instrument Panel Wire (Instrument Panel Center)            |

 : Ground Points

| Code | See Page    | Ground Points Location          |
|------|-------------|---------------------------------|
| A1   | 64 (2GR-FE) | Front Left Fender               |
| A2   |             |                                 |
| A3   | 66          | Left Cowl Side Panel            |
| C4   | 64 (2GR-FE) | Cylinder Head                   |
| C7   | 64 (2GR-FE) | Left Side of the Cylinder Block |
| F1   | 66          | Instrument Panel Left           |



# ECT and A/T Indicator for 2AZ-FE

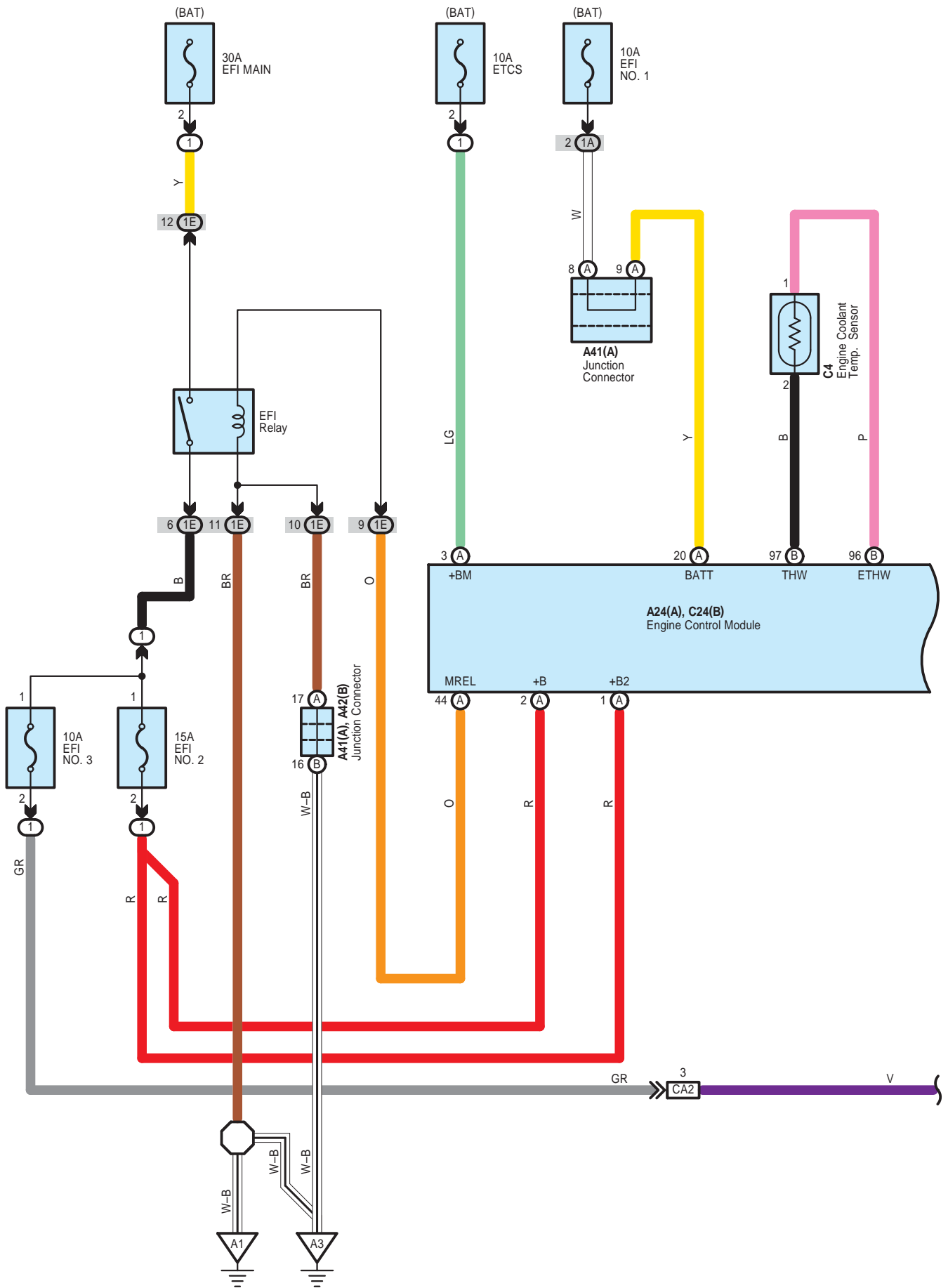

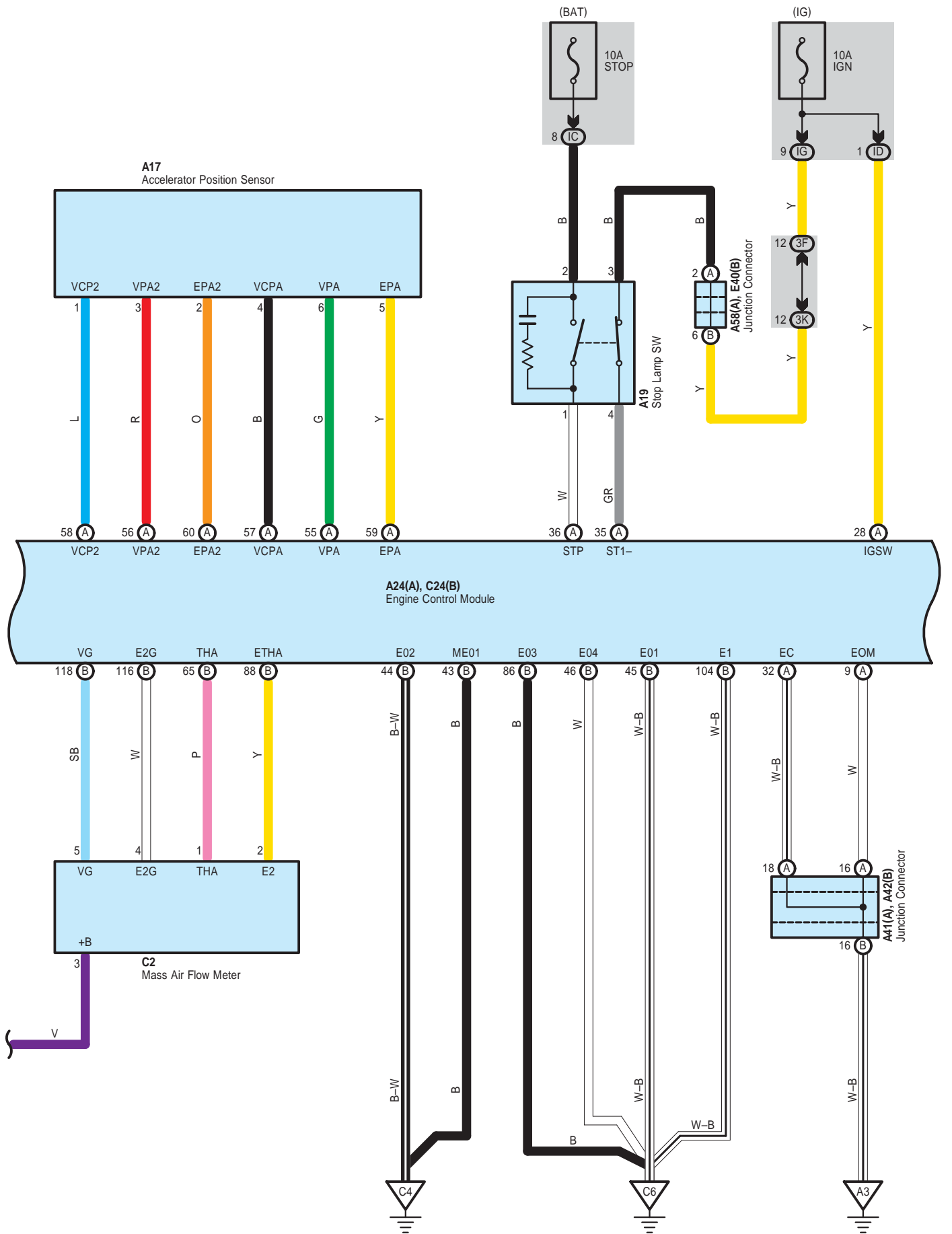

# ECT and A/T Indicator for 2AZ-FE

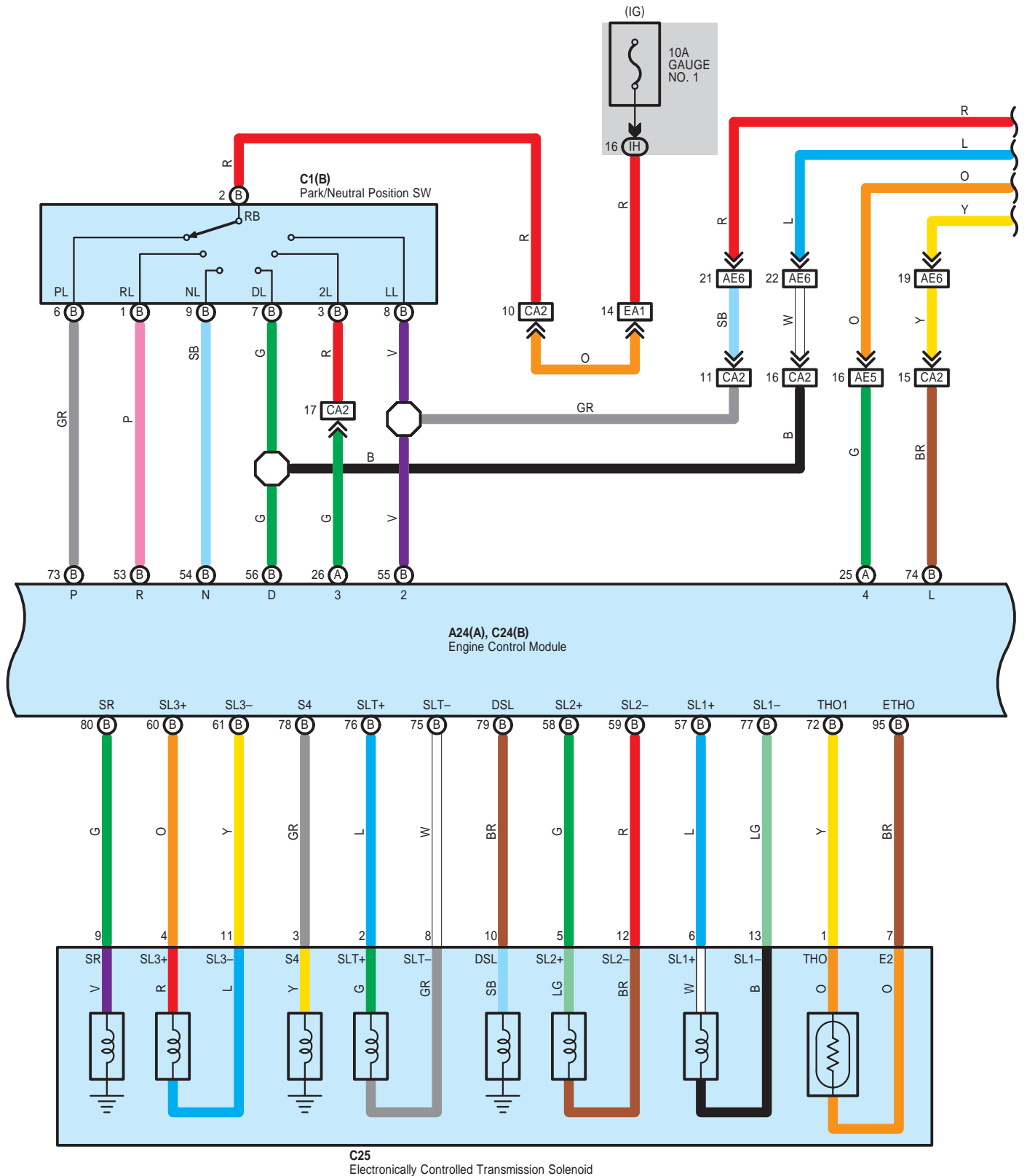

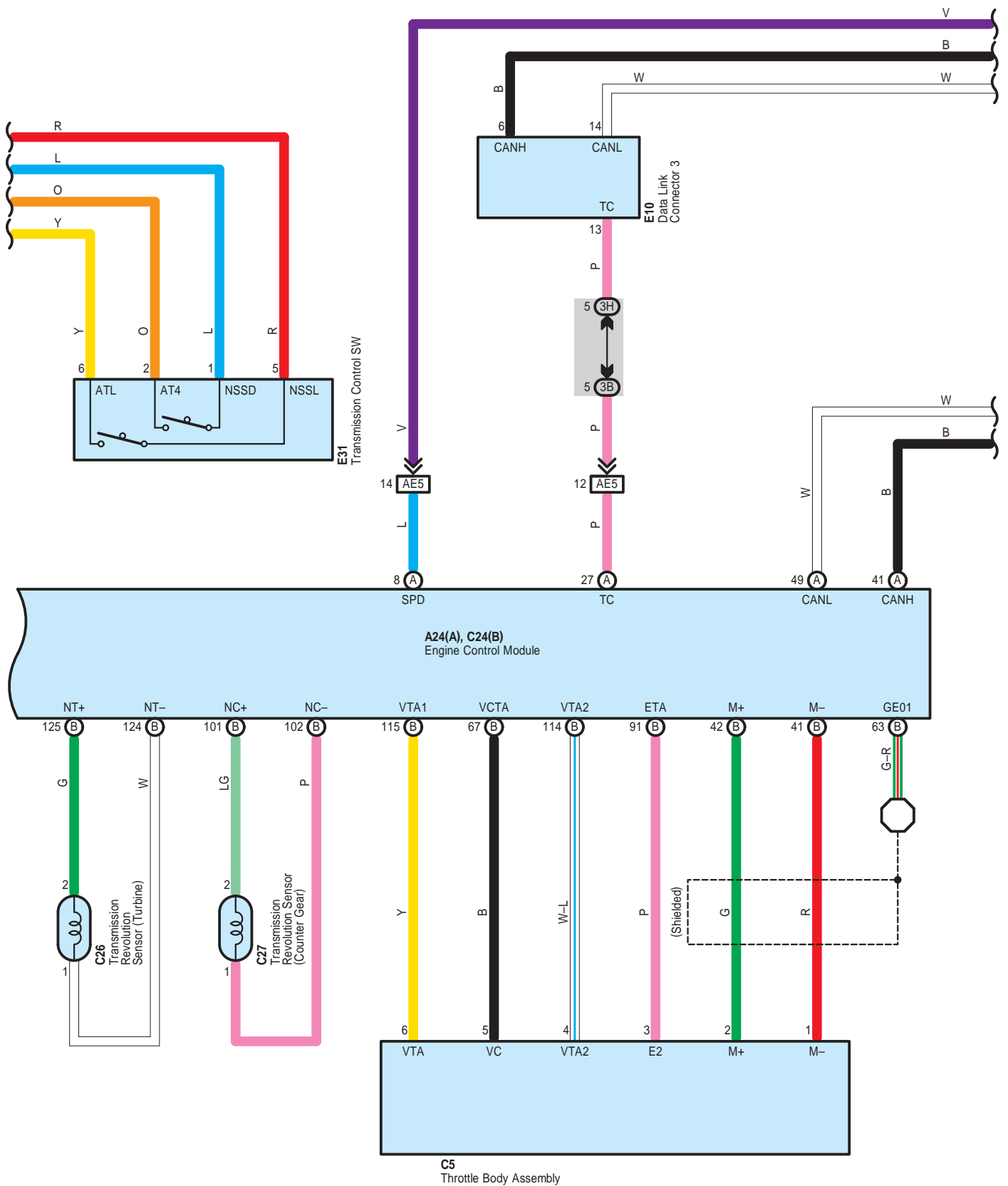

# ECT and A/T Indicator for 2AZ-FE

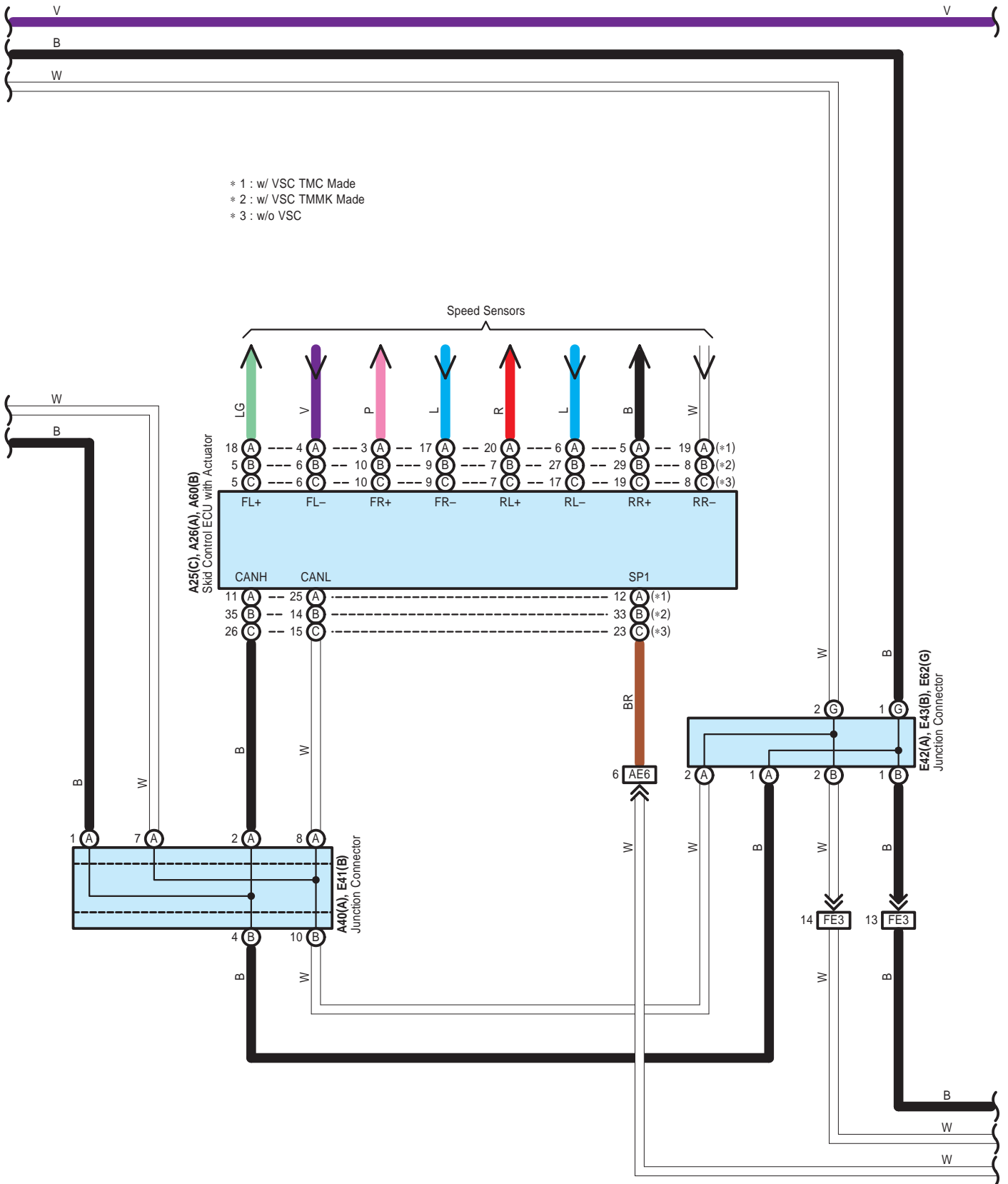

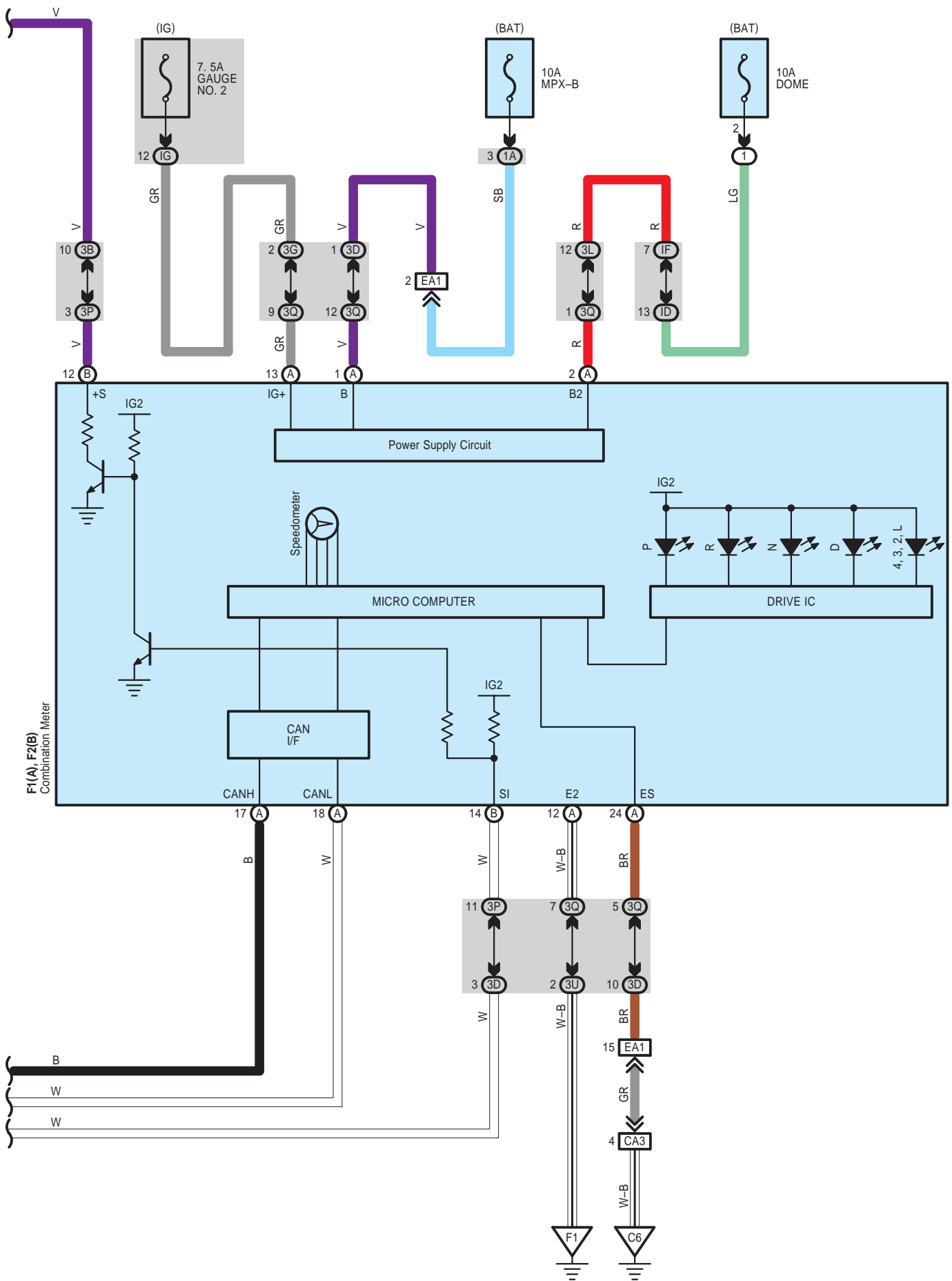

# ECT and A/T Indicator for 2AZ-FE

## System Outline

### 1. Line Pressure Optimal Control

Through the use of the solenoid valve SLT, the line pressure is optimally controlled in accordance with the engine torque information, as well as with the internal operating conditions of the torque converter and the transaxle. Accordingly, the line pressure can be controlled minutely in accordance with the engine output, traveling condition, and the ATF temperature, thus realizing smooth shift characteristics and optimizing the workload in the oil pump.

### 2. Clutch Pressure Optimal Control

The engine control module monitors the signals from various types of sensor such as the input turbine speed sensor, allowing shift solenoid valves SL1, SL2 and SL3 to minutely control the clutch pressure in accordance with engine output and driving conditions. As a result, smooth shift characteristics have been realized.

### 3. Shifting Control in Uphill/Downhill Traveling

This control minimizes the shifting of gears when the driver operates the accelerator pedal while driving on a winding road with ups and downs, in order to ensure a smooth drive.

### 4. Flex Lock-Up Clutch Control

The flex lock-up clutch control operates during acceleration, in the 4th and 5th gear in the D range, and during deceleration, in the 4th and 5th gear in the D range and in the 4th gear in the 4 range.

## ○ : Parts Location

| Code | See Page | Code        | See Page | Code        | See Page    |     |    |    |
|------|----------|-------------|----------|-------------|-------------|-----|----|----|
| A17  | 59       | A60         | B        | 53 (2AZ-FE) | E10         | 56  |    |    |
| A19  | 59       | C1          | B        | 54 (2AZ-FE) | E31         | 56  |    |    |
| A24  | A        | 52 (2AZ-FE) | C2       | 54 (2AZ-FE) | E40         | B   | 57 |    |
| A25  | C        | 52 (2AZ-FE) | C4       | 54 (2AZ-FE) | E41         | B   | 57 |    |
| A26  | A        | 52 (2AZ-FE) | C5       | 54 (2AZ-FE) | E42         | A   | 57 |    |
| A40  | A        | 59          | C24      | B           | 55 (2AZ-FE) | E43 | B  | 57 |
| A41  | A        | 59          | C25      | 55 (2AZ-FE) | E62         | G   | 57 |    |
| A42  | B        | 59          | C26      | 55 (2AZ-FE) | F1          | A   | 58 |    |
| A58  | A        | 59          | C27      | 55 (2AZ-FE) | F2          | B   | 58 |    |

## ○ : Relay Blocks

| Code | See Page | Relay Blocks (Relay Block Location)       |
|------|----------|---|
| 1    | 22       | Engine Room R/B (Engine Compartment Left) |

## ○ : Junction Block and Wire Harness Connector

| Code | See Page | Junction Block and Wire Harness (Connector Location)                   |
|------|----------|--|
| 1A   | 25       | Engine Room Main Wire and Engine Room J/B (Engine Compartment Left)    |
| 1E   |          |  |
| 3B   | 36       | Instrument Panel Wire and J/B No.3 (Behind the Combination Meter)      |
| 3D   |          |  |
| 3F   |          |  |
| 3G   |          |  |
| 3H   |          |  |
| 3K   |          |  |
| 3L   |          |  |
| 3P   | 36       | Instrument Panel No.2 Wire and J/B No.3 (Behind the Combination Meter) |
| 3Q   |          |  |
| 3U   |          |  |
| IC   | 30       | Engine Room Main Wire and Instrument Panel J/B (Cowl Side Left)        |
| ID   | 30       | Instrument Panel Wire and Instrument Panel J/B (Cowl Side Left)        |
| IF   |          |  |
| IG   |          |  |
| IH   |          |  |

 : Connector Joining Wire Harness and Wire Harness

| Code | See Page    | Joining Wire Harness and Wire Harness (Connector Location)                                |
|------|-------------|---|
| AE5  | 66          | Engine Room Main Wire and Instrument Panel Wire (Instrument Panel Right)                  |
| AE6  |             |   |
| CA2  | 65 (2AZ-FE) | Engine Wire and Engine Room Main Wire (Inside of the Engine Room R/B and Engine Room J/B) |
| CA3  |             |   |
| EA1  | 66          | Instrument Panel Wire and Engine Room Main Wire (Left Kick Panel)                         |
| FE3  | 66          | Instrument Panel No.2 Wire and Instrument Panel Wire (Instrument Panel Center)            |

 : Ground Points

| Code | See Page    | Ground Points Location |
|------|-------------|------------------------|
| A1   | 65 (2AZ-FE) | Front Left Fender      |
| A3   | 66          | Left Cowl Side Panel   |
| C4   | 65 (2AZ-FE) | Cylinder Block         |
| C6   |             |                        |
| F1   | 66          | Instrument Panel Left  |



# Shift Lock

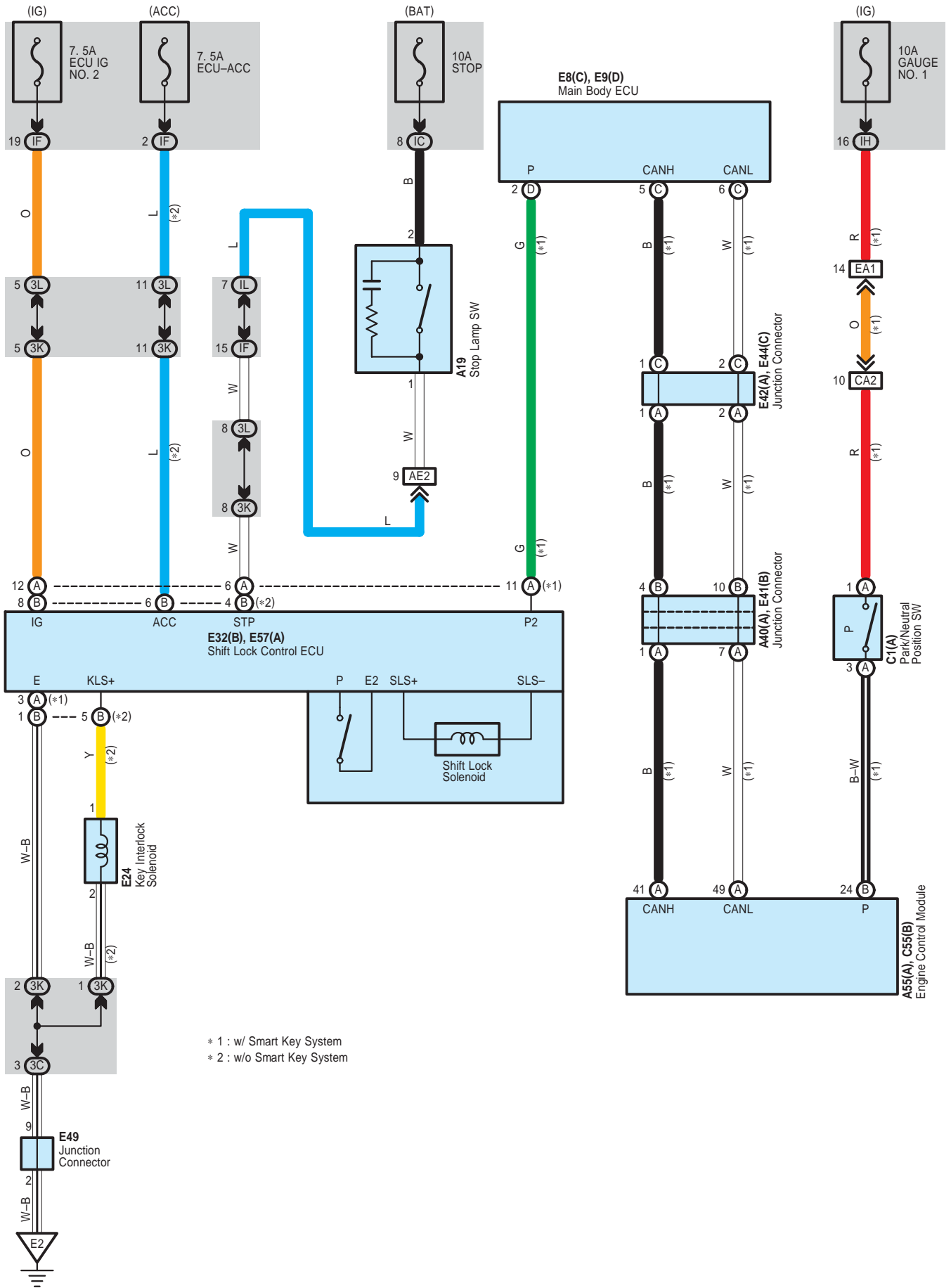

## System Outline

### Shift Lock Mechanism

If the brake pedal is depressed with the power SW is pushed to IG ON position (Power SW type), or the ignition SW is turned to ON (Ignition SW type), the shift lock control ECU is activated, allowing the driver to change the shift lever to a position other than the P position.

### ○ : Parts Location

| Code | See Page | Code        | See Page | Code | See Page    |    |
|------|----------|-------------|----------|------|-------------|----|
| A19  | A        | 59          | C55      | B    | 51 (2GR-FE) |    |
|      | B        | 59          | E8       | C    | 56          |    |
| A40  | A        | 59          | E9       | D    | 56          |    |
| A55  | A        | 49 (2GR-FE) | E24      |      | 56          |    |
| C1   | A        | 50 (2GR-FE) | E32      | B    | 56          |    |
|      |          |             |          | E41  | B           | 57 |
|      |          |             |          | E42  | A           | 57 |
|      |          |             |          | E44  | C           | 57 |
|      |          |             |          | E49  |             | 57 |
|      |          |             |          | E57  | A           | 57 |

### ○ : Junction Block and Wire Harness Connector

| Code | See Page | Junction Block and Wire Harness (Connector Location)              |
|------|----------|---|
| 3C   | 36       | Instrument Panel Wire and J/B No.3 (Behind the Combination Meter) |
| 3K   |          |   |
| 3L   |          |   |
| IC   | 30       | Engine Room Main Wire and Instrument Panel J/B (Cowl Side Left)   |
| IF   | 30       | Instrument Panel Wire and Instrument Panel J/B (Cowl Side Left)   |
| IH   | 31       |   |
| IL   | 30       |   |

### □ : Connector Joining Wire Harness and Wire Harness

| Code | See Page    | Joining Wire Harness and Wire Harness (Connector Location)                                |
|------|-------------|---|
| AE2  | 66          | Engine Room Main Wire and Instrument Panel Wire (Right Side of the Instrument Panel J/B)  |
| CA2  | 64 (2GR-FE) | Engine Wire and Engine Room Main Wire (Inside of the Engine Room R/B and Engine Room J/B) |
| EA1  | 66          | Instrument Panel Wire and Engine Room Main Wire (Left Kick Panel)                         |

### ▽ : Ground Points

| Code | See Page | Ground Points Location    |
|------|----------|---------------------------|
| E2   | 66       | Instrument Panel Brace LH |

# Power Seat for Driver's Seat

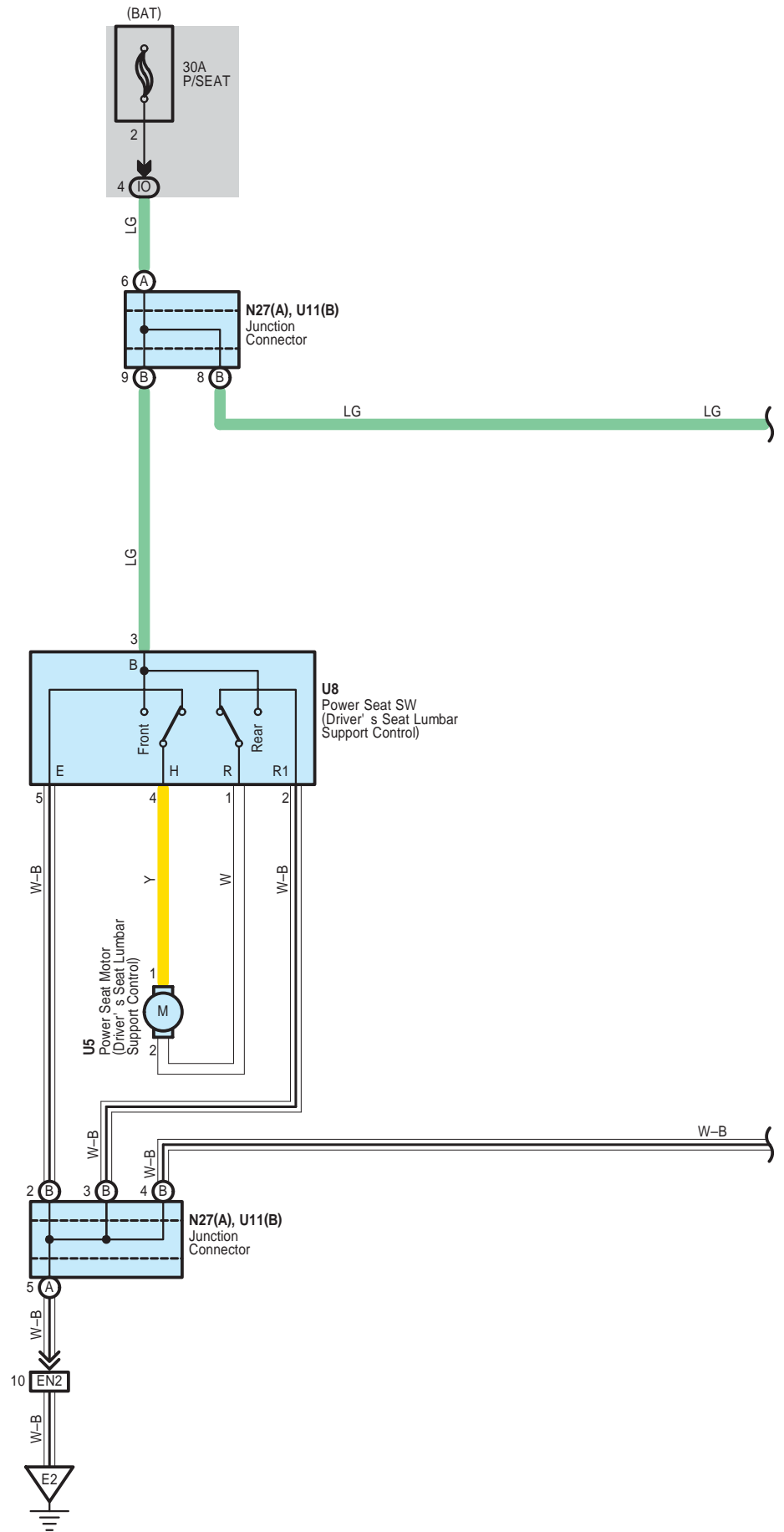

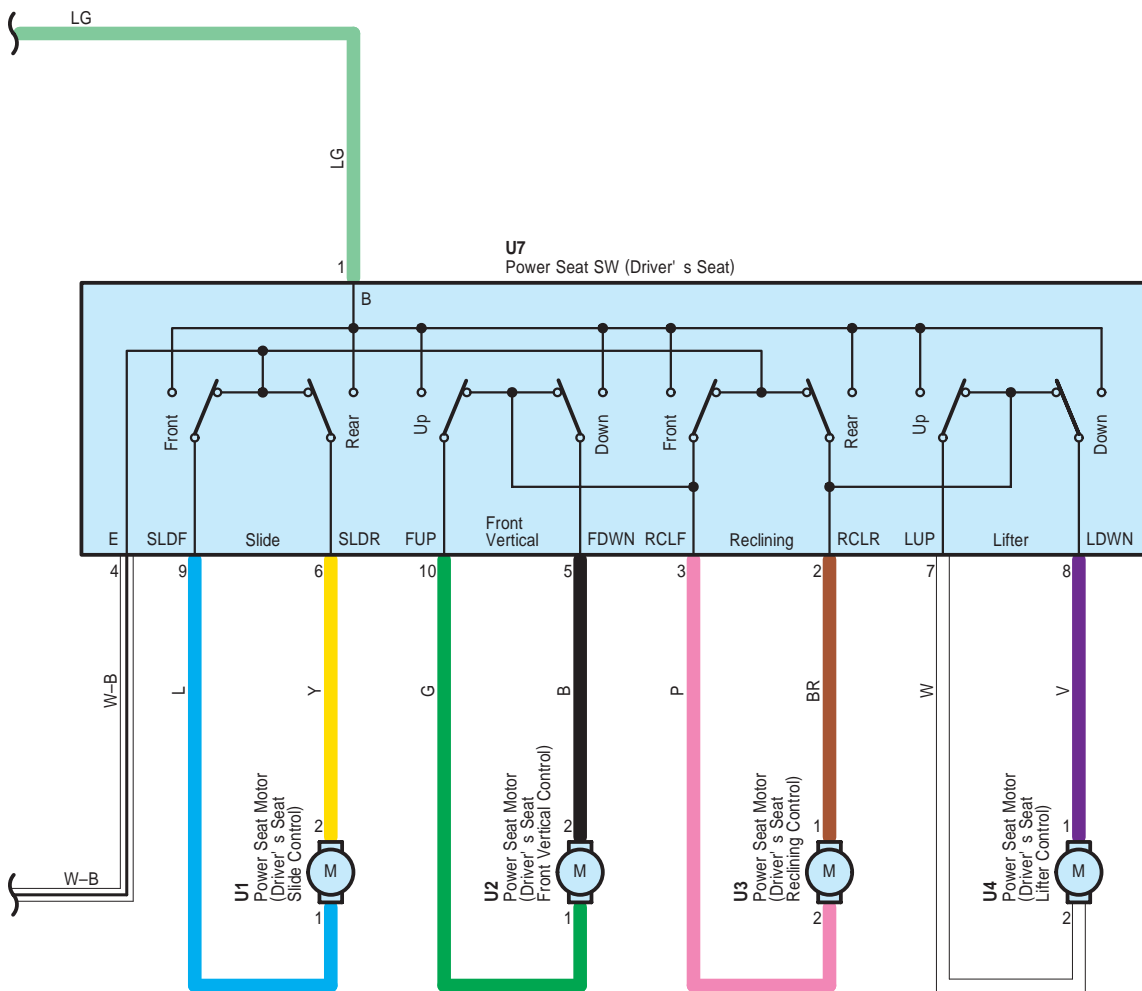

# Power Seat for Driver's Seat

## : Parts Location

| Code |   | See Page | Code | See Page | Code | See Page  |
|------|---|----------|------|----------|------|-----------|
| N27  | A | 62 (*1)  | U3   | 62 (*1)  | U7   | 62 (*1)   |
| U1   |   | 62 (*1)  | U4   | 62 (*1)  | U8   | 62 (*1)   |
| U2   |   | 62 (*1)  | U5   | 62 (*1)  | U11  | B 62 (*1) |

## : Junction Block and Wire Harness Connector

| Code | See Page | Junction Block and Wire Harness (Connector Location) |
|------|----------|--|
| IO   | 30       | Floor Wire and Instrument Panel J/B (Cowl Side Left) |

## : Connector Joining Wire Harness and Wire Harness

| Code | See Page | Joining Wire Harness and Wire Harness (Connector Location) |
|------|----------|--|
| EN2  | 66       | Instrument Panel Wire and Floor Wire (Left Kick Panel)     |

## : Ground Points

| Code | See Page | Ground Points Location    |
|------|----------|---------------------------|
| E2   | 66       | Instrument Panel Brace LH |

\* 1 : w/ Power Seat      \* 2 : w/o Power Seat



# Power Seat for Front Passenger's Seat

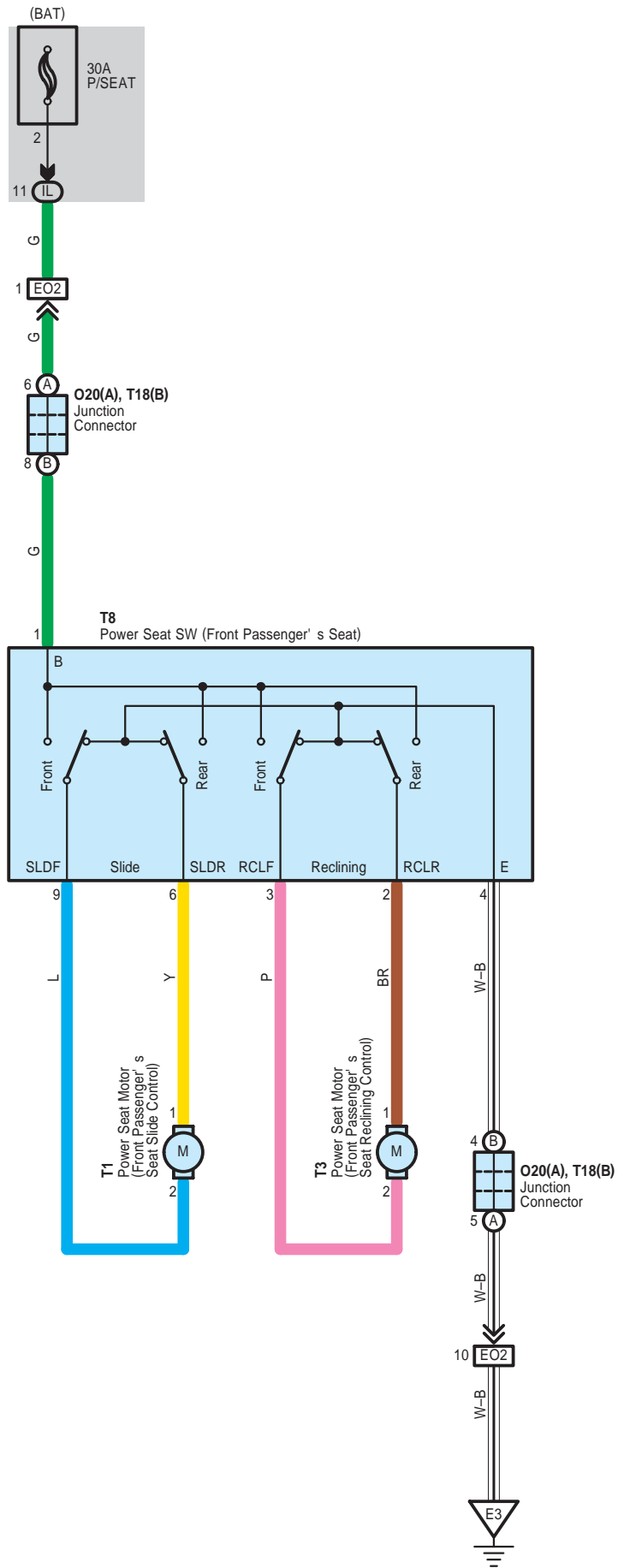

 : **Parts Location**

| Code |    | See Page | Code |         | See Page | Code |         | See Page |
|------|----|----------|------|---------|----------|------|---------|----------|
| O20  | A  | 62 (*1)  | T3   | 62 (*1) | T18      | B    | 62 (*1) |          |
|      | T1 | 62 (*1)  | T8   | 62 (*1) |          |      |         |          |

 : **Junction Block and Wire Harness Connector**

| Code | See Page | Junction Block and Wire Harness (Connector Location)            |
|------|----------|---|
| IL   | 30       | Instrument Panel Wire and Instrument Panel J/B (Cowl Side Left) |

 : **Connector Joining Wire Harness and Wire Harness**

| Code | See Page | Joining Wire Harness and Wire Harness (Connector Location)   |
|------|----------|--|
| EO2  | 66       | Instrument Panel Wire and Floor No.2 Wire (Right Kick Panel) |

 : **Ground Points**

| Code | See Page | Ground Points Location |
|------|----------|------------------------|
| E3   | 66       | Instrument Panel Right |

\* 1 : w/ Power Seat      \* 2 : w/o Power Seat



# Seat Heater

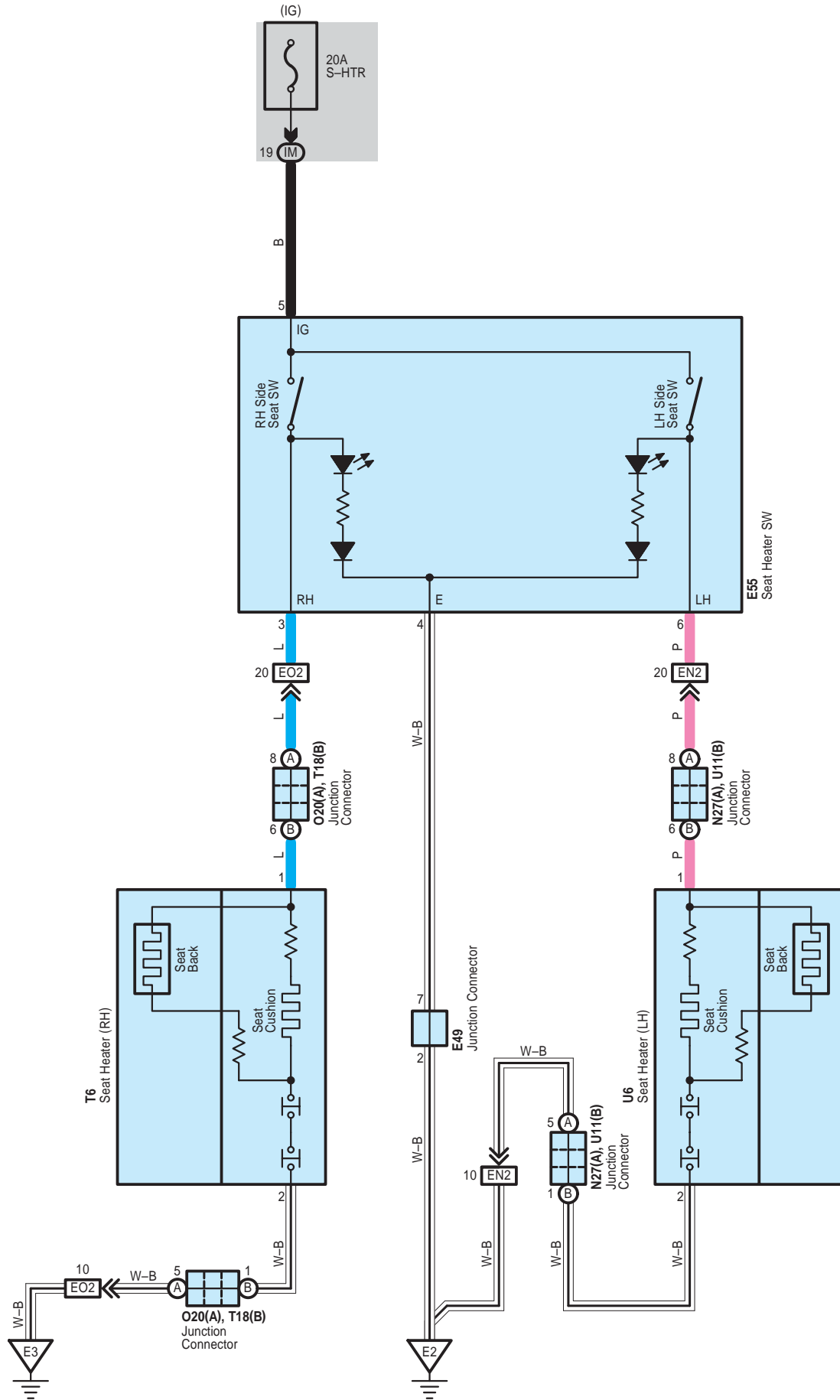

 : **Parts Location**

| Code | See Page | Code    | See Page | Code    | See Page |         |         |
|------|----------|---------|----------|---------|----------|---------|---------|
| E49  | 57       | O20     | A        | 62 (*1) | U6       | 62 (*1) |         |
| E55  | 57       | T6      |          | 62 (*1) | U11      | B       | 62 (*1) |
| N27  | A        | 62 (*1) | T18      | B       | 62 (*1)  |         |         |

 : **Junction Block and Wire Harness Connector**

| Code | See Page | Junction Block and Wire Harness (Connector Location)            |
|------|----------|---|
| IM   | 30       | Instrument Panel Wire and Instrument Panel J/B (Cowl Side Left) |

 : **Connector Joining Wire Harness and Wire Harness**

| Code | See Page | Joining Wire Harness and Wire Harness (Connector Location)   |
|------|----------|--|
| EN2  | 66       | Instrument Panel Wire and Floor Wire (Left Kick Panel)       |
| EO2  | 66       | Instrument Panel Wire and Floor No.2 Wire (Right Kick Panel) |

 : **Ground Points**

| Code | See Page | Ground Points Location    |
|------|----------|---------------------------|
| E2   | 66       | Instrument Panel Brace LH |
| E3   | 66       | Instrument Panel Right    |

\* 1 : w/ Power Seat      \* 2 : w/o Power Seat

# Sliding Roof

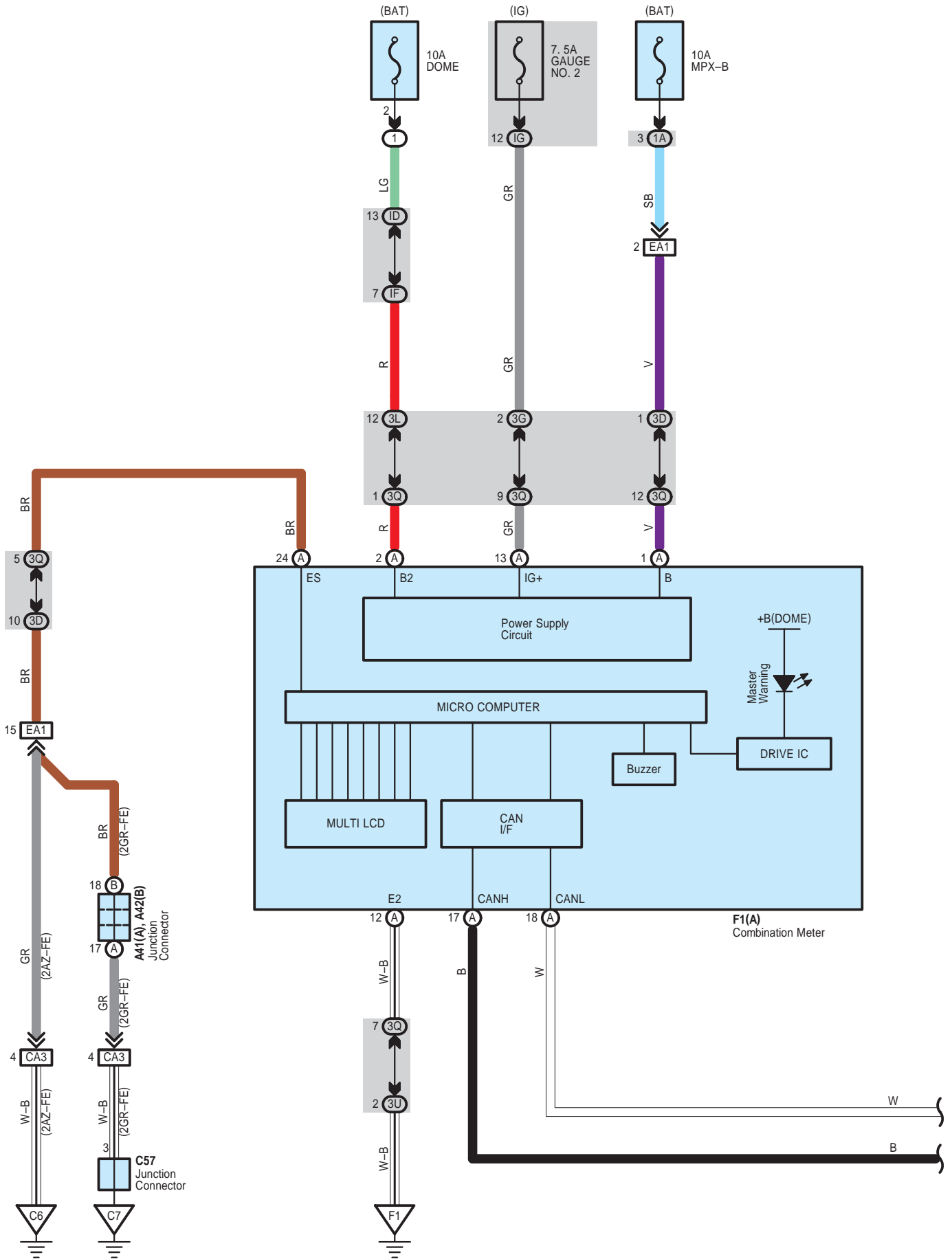

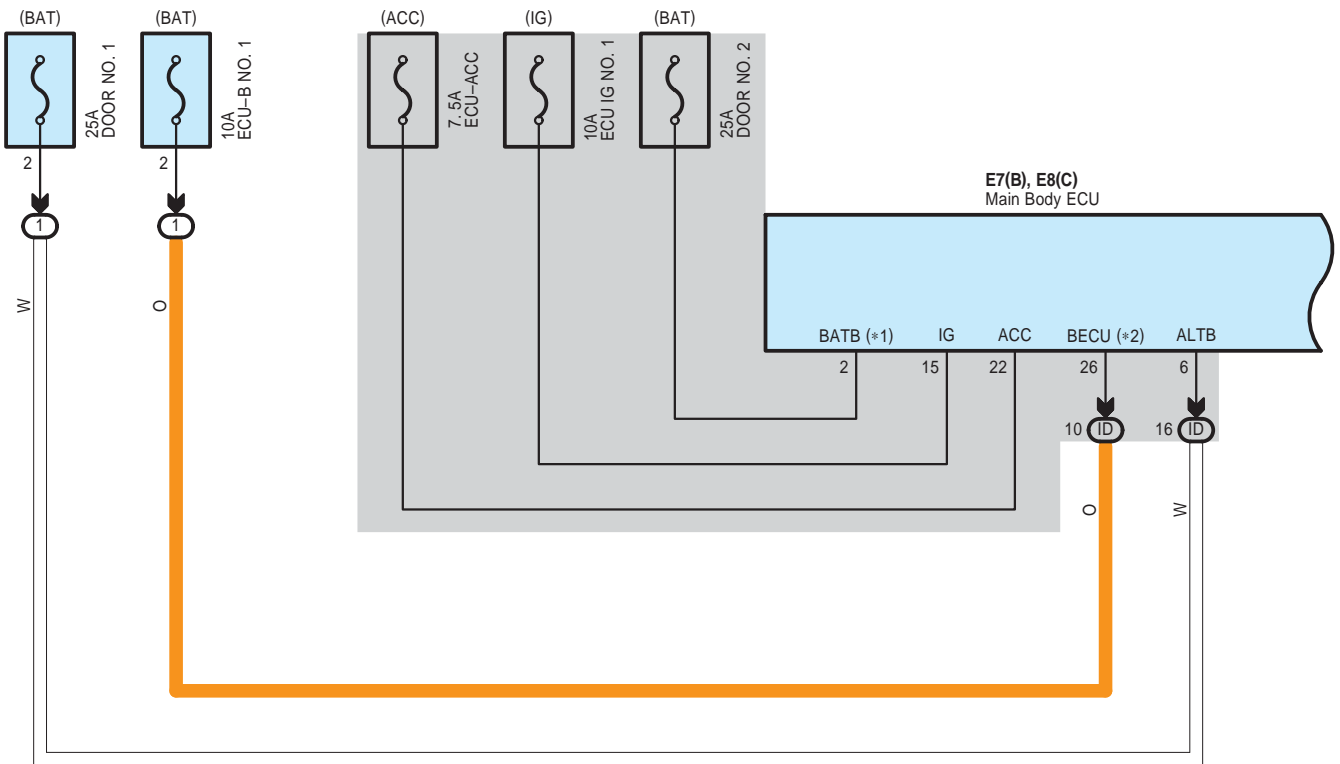

\* 1 : w/ Smart Key System  
 \* 2 : w/o Smart Key System



# Sliding Roof

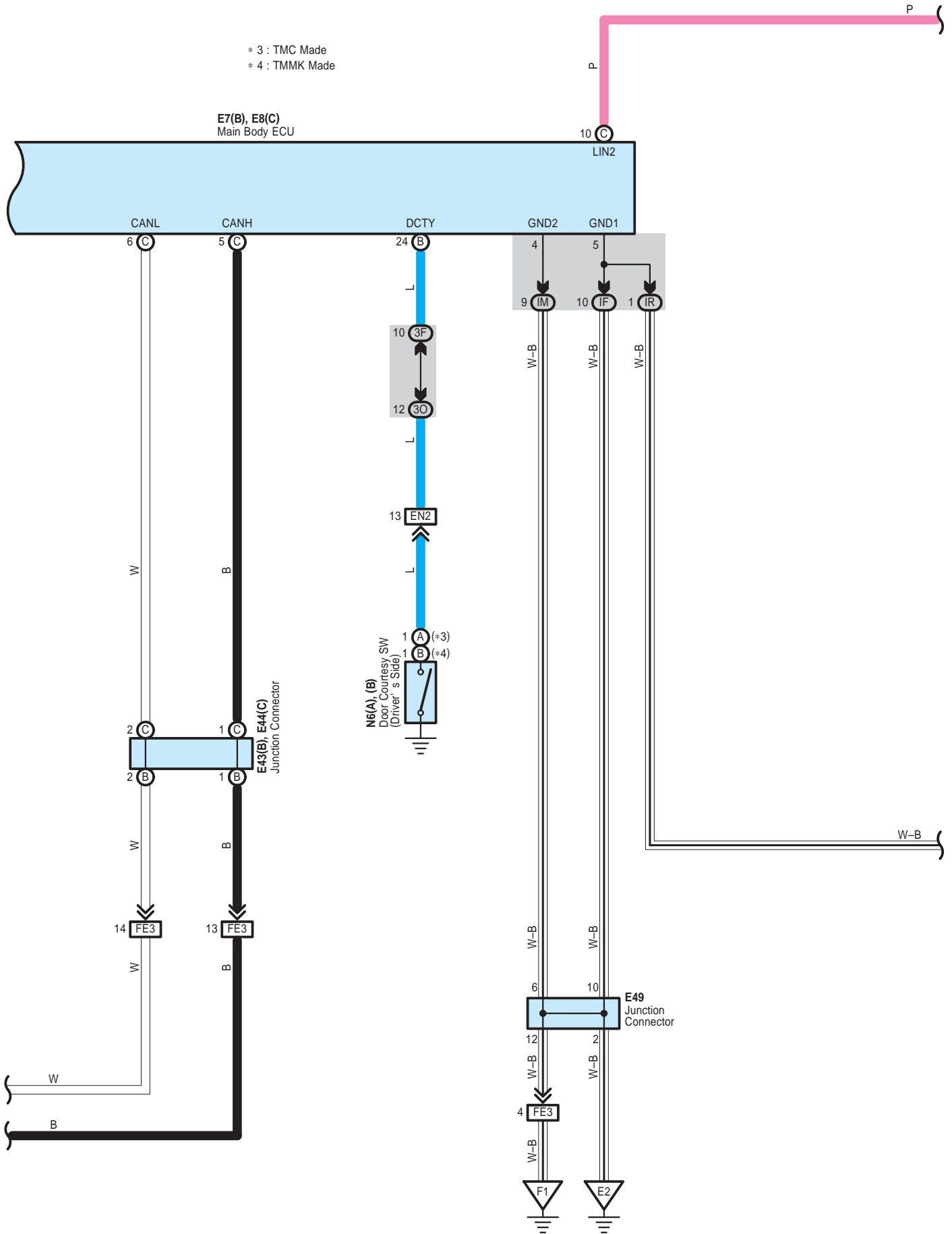

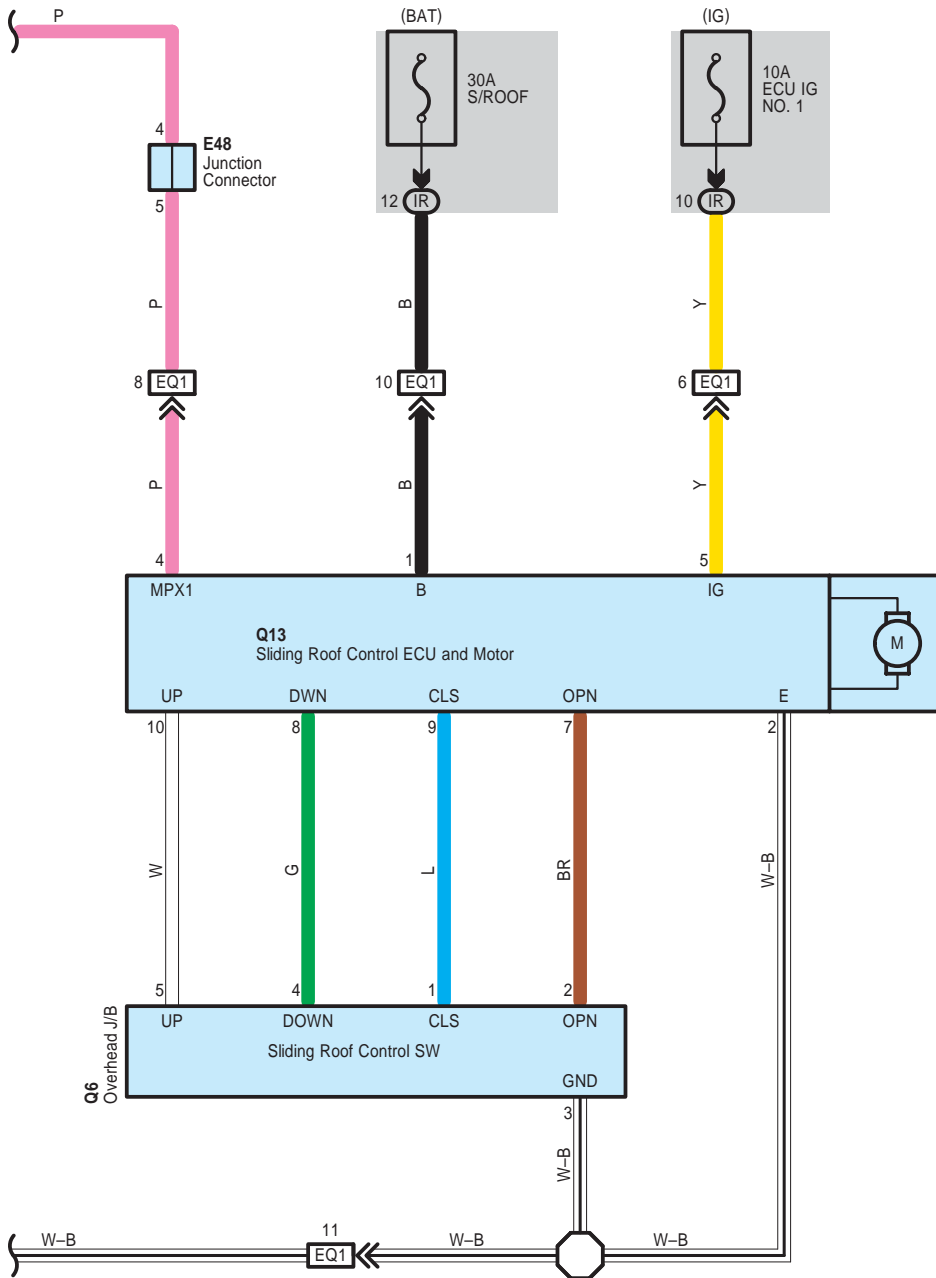

# Sliding Roof

## ○ : Parts Location

| Code |   | See Page    | Code |   | See Page | Code |   | See Page |
|------|---|-------------|------|---|----------|------|---|----------|
| A41  | A | 59          | E43  | B | 57       | N6   | A | 60       |
| A42  | B | 59          | E44  | C | 57       |      | B | 60       |
| C57  |   | 51 (2GR-FE) | E48  |   | 57       | Q6   |   | 61       |
| E7   | B | 56          | E49  |   | 57       | Q13  |   | 61       |
| E8   | C | 56          | F1   | A | 58       |      |   |          |

## ○ : Relay Blocks

| Code | See Page | Relay Blocks (Relay Block Location)       |
|------|----------|---|
| 1    | 22       | Engine Room R/B (Engine Compartment Left) |

## ○ : Junction Block and Wire Harness Connector

| Code | See Page | Junction Block and Wire Harness (Connector Location)                   |
|------|----------|--|
| 1A   | 25       | Engine Room Main Wire and Engine Room J/B (Engine Compartment Left)    |
| 3D   | 36       | Instrument Panel Wire and J/B No.3 (Behind the Combination Meter)      |
| 3F   |          |  |
| 3G   |          |  |
| 3L   |          |  |
| 3O   |          |  |
| 3Q   | 36       | Instrument Panel No.2 Wire and J/B No.3 (Behind the Combination Meter) |
| 3U   |          |  |
| ID   | 30       | Engine Room Main Wire and Instrument Panel J/B (Cowl Side Left)        |
| IF   | 30       | Instrument Panel Wire and Instrument Panel J/B (Cowl Side Left)        |
| IG   | 31       |  |
| IM   | 30       |  |
| IR   |          |  |

## □ : Connector Joining Wire Harness and Wire Harness

| Code | See Page    | Joining Wire Harness and Wire Harness (Connector Location)                                |
|------|-------------|---|
| CA3  | 64 (2GR-FE) | Engine Wire and Engine Room Main Wire (Inside of the Engine Room R/B and Engine Room J/B) |
|      | 65 (2AZ-FE) |   |
| EA1  | 66          | Instrument Panel Wire and Engine Room Main Wire (Left Kick Panel)                         |
| EN2  | 66          | Instrument Panel Wire and Floor Wire (Left Kick Panel)                                    |
| EQ1  | 66          | Instrument Panel Wire and Roof Wire (Lower Part of Front Pillar LH)                       |
| FE3  | 66          | Instrument Panel No.2 Wire and Instrument Panel Wire (Instrument Panel Center)            |

## ▽ : Ground Points

| Code | See Page    | Ground Points Location          |
|------|-------------|---------------------------------|
| C6   | 65 (2AZ-FE) | Cylinder Block                  |
| C7   | 64 (2GR-FE) | Left Side of the Cylinder Block |
| E2   | 66          | Instrument Panel Brace LH       |
| F1   | 66          | Instrument Panel Left           |





# Garage Door Opener

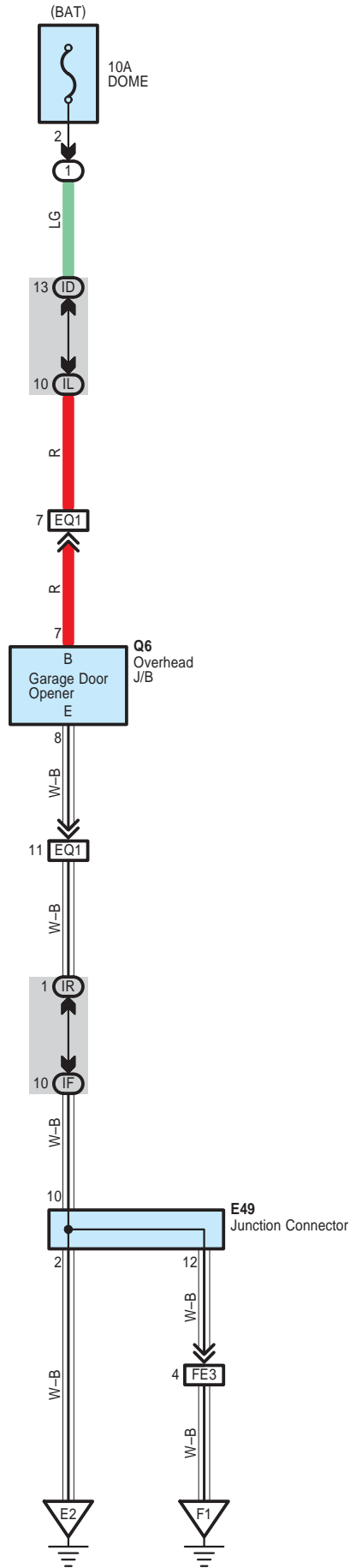

 : **Parts Location**

| Code | See Page | Code | See Page | Code | See Page |
|------|----------|------|----------|------|----------|
| E49  | 57       | Q6   | 61       |      |          |

 : **Relay Blocks**

| Code | See Page | Relay Blocks (Relay Block Location)       |
|------|----------|---|
| 1    | 22       | Engine Room R/B (Engine Compartment Left) |

 : **Junction Block and Wire Harness Connector**

| Code | See Page | Junction Block and Wire Harness (Connector Location)            |
|------|----------|---|
| ID   | 30       | Engine Room Main Wire and Instrument Panel J/B (Cowl Side Left) |
| IF   | 30       | Instrument Panel Wire and Instrument Panel J/B (Cowl Side Left) |
| IL   |          |   |
| IR   |          |   |

 : **Connector Joining Wire Harness and Wire Harness**

| Code | See Page | Joining Wire Harness and Wire Harness (Connector Location)                     |
|------|----------|--|
| EQ1  | 66       | Instrument Panel Wire and Roof Wire (Lower Part of Front Pillar LH)            |
| FE3  | 66       | Instrument Panel No.2 Wire and Instrument Panel Wire (Instrument Panel Center) |

 : **Ground Points**

| Code | See Page | Ground Points Location    |
|------|----------|---------------------------|
| E2   | 66       | Instrument Panel Brace LH |
| F1   | 66       | Instrument Panel Left     |

# Automatic Glare-Resistant EC Mirror

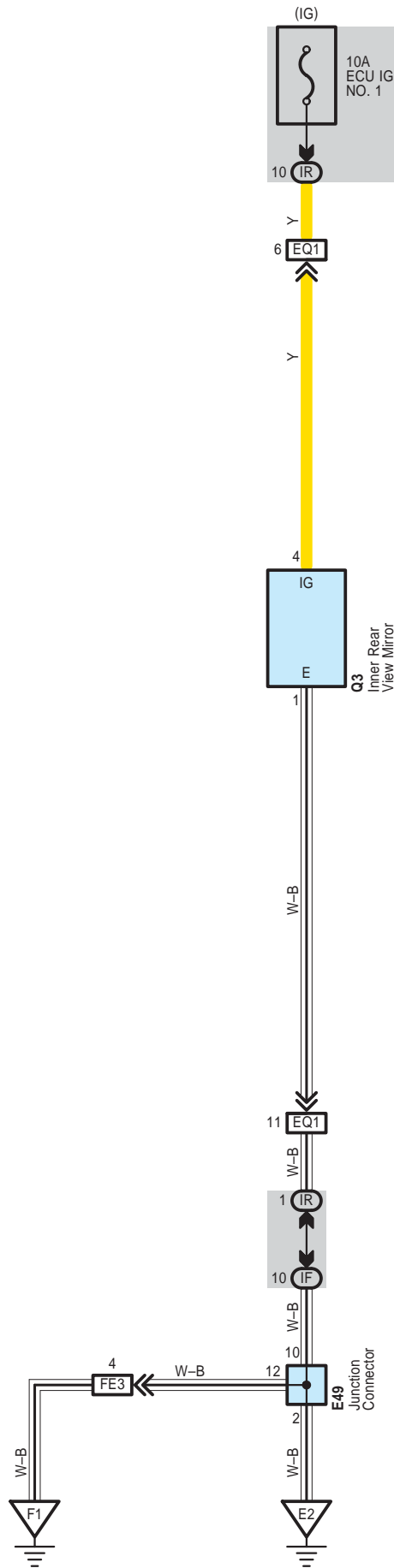

 : **Parts Location**

| Code | See Page | Code | See Page | Code | See Page |
|------|----------|------|----------|------|----------|
| E49  | 57       | Q3   | 61       |      |          |

 : **Junction Block and Wire Harness Connector**

| Code | See Page | Junction Block and Wire Harness (Connector Location)            |
|------|----------|---|
| IF   | 30       | Instrument Panel Wire and Instrument Panel J/B (Cowl Side Left) |
| IR   |          |   |

 : **Connector Joining Wire Harness and Wire Harness**

| Code | See Page | Joining Wire Harness and Wire Harness (Connector Location)                     |
|------|----------|--|
| EQ1  | 66       | Instrument Panel Wire and Roof Wire (Lower Part of Front Pillar LH)            |
| FE3  | 66       | Instrument Panel No.2 Wire and Instrument Panel Wire (Instrument Panel Center) |

 : **Ground Points**

| Code | See Page | Ground Points Location    |
|------|----------|---------------------------|
| E2   | 66       | Instrument Panel Brace LH |
| F1   | 66       | Instrument Panel Left     |

# Remote Control Mirror

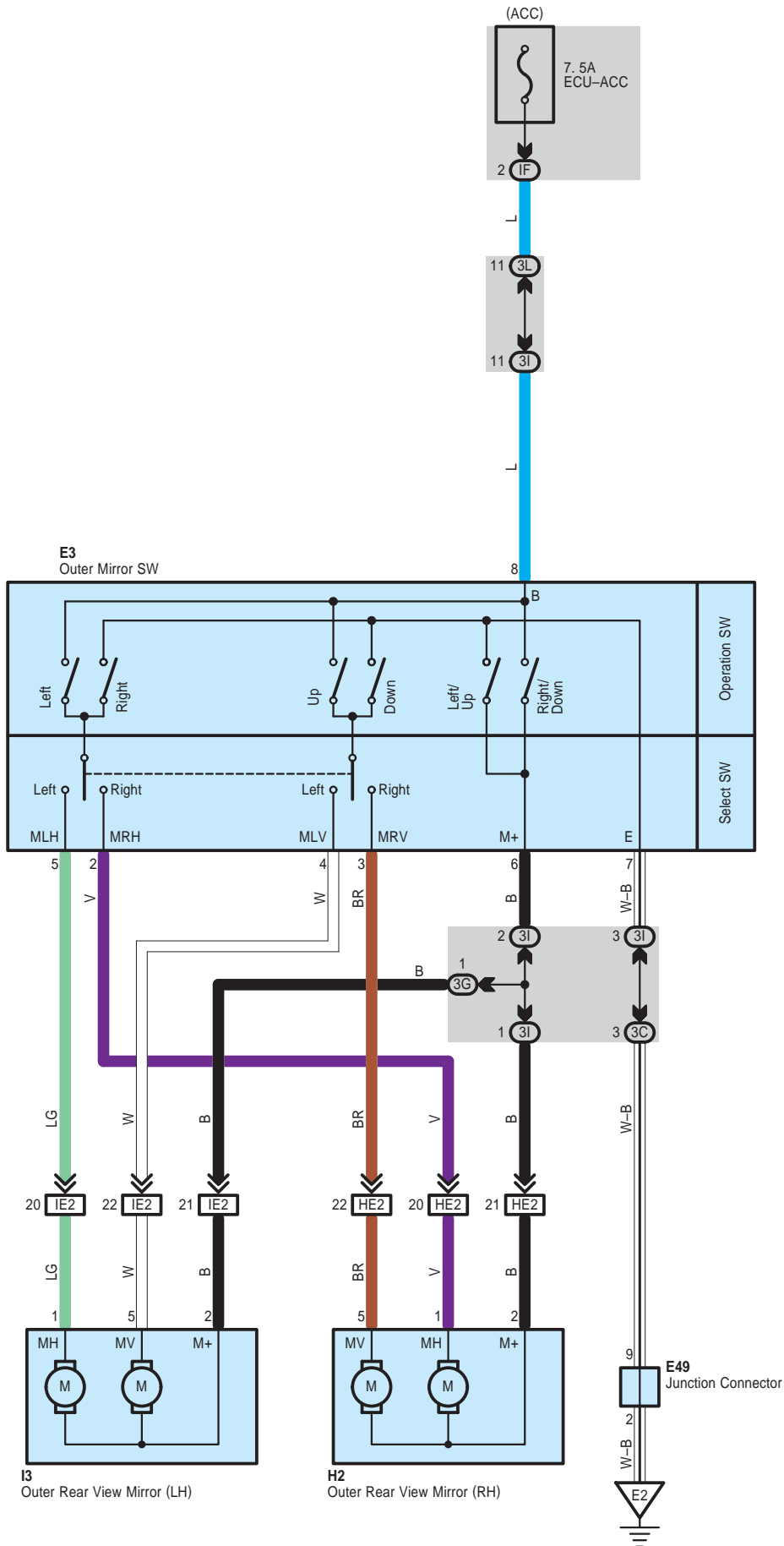

 : **Parts Location**

| Code | See Page | Code | See Page | Code | See Page |
|------|----------|------|----------|------|----------|
| E3   | 56       | H2   | 61       |      |          |
| E49  | 57       | I3   | 61       |      |          |

 : **Junction Block and Wire Harness Connector**

| Code | See Page | Junction Block and Wire Harness (Connector Location)              |
|------|----------|---|
| 3C   | 36       | Instrument Panel Wire and J/B No.3 (Behind the Combination Meter) |
| 3G   |          |   |
| 3I   |          |   |
| 3L   |          |   |
| IF   | 30       | Instrument Panel Wire and Instrument Panel J/B (Cowl Side Left)   |

 : **Connector Joining Wire Harness and Wire Harness**

| Code | See Page | Joining Wire Harness and Wire Harness (Connector Location)      |
|------|----------|---|
| HE2  | 66       | Front Door RH Wire and Instrument Panel Wire (Right Kick Panel) |
| IE2  | 66       | Front Door LH Wire and Instrument Panel Wire (Left Kick Panel)  |

 : **Ground Points**

| Code | See Page | Ground Points Location    |
|------|----------|---------------------------|
| E2   | 66       | Instrument Panel Brace LH |

# Rear Window Defogger and Mirror Heater

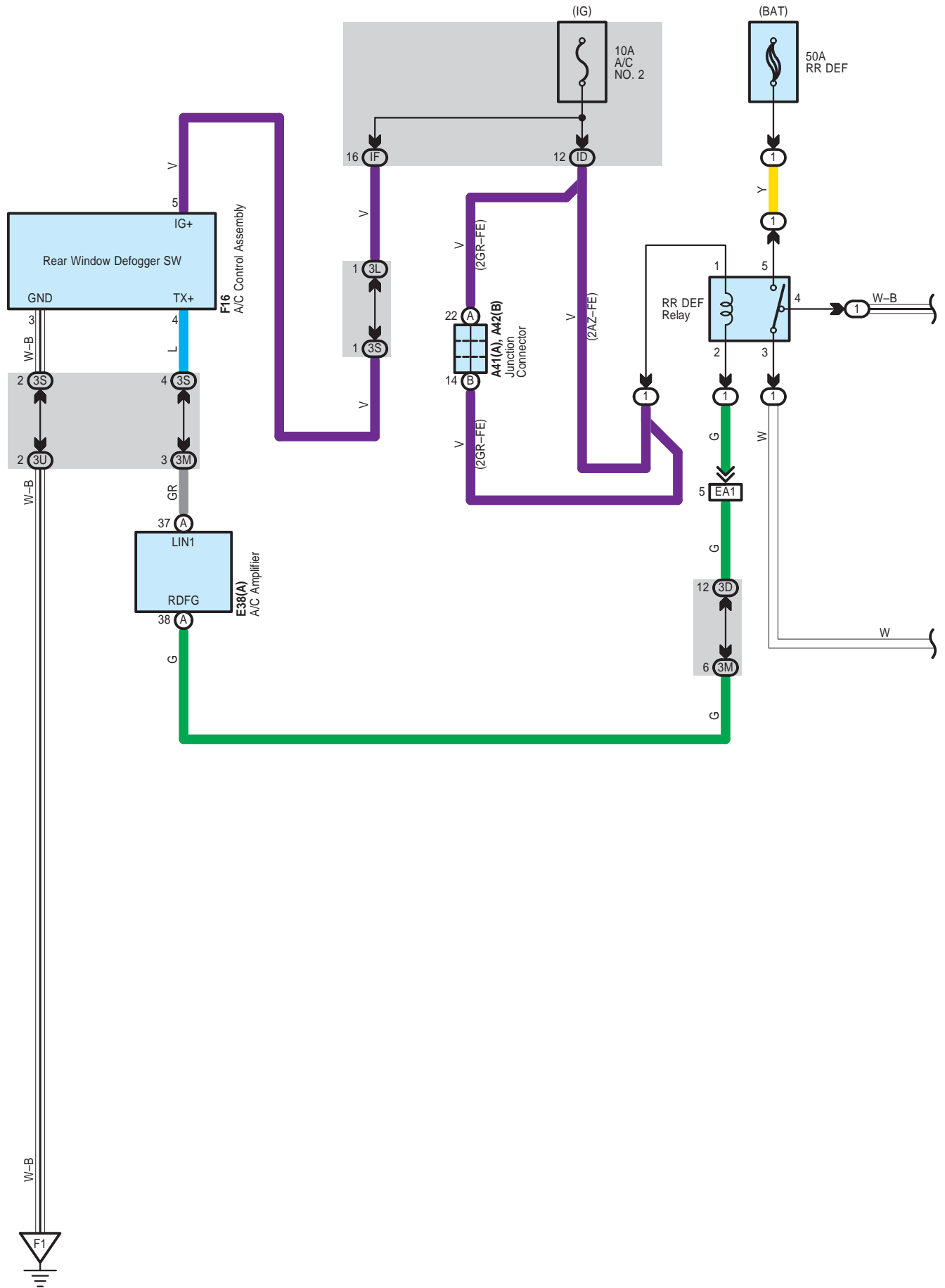

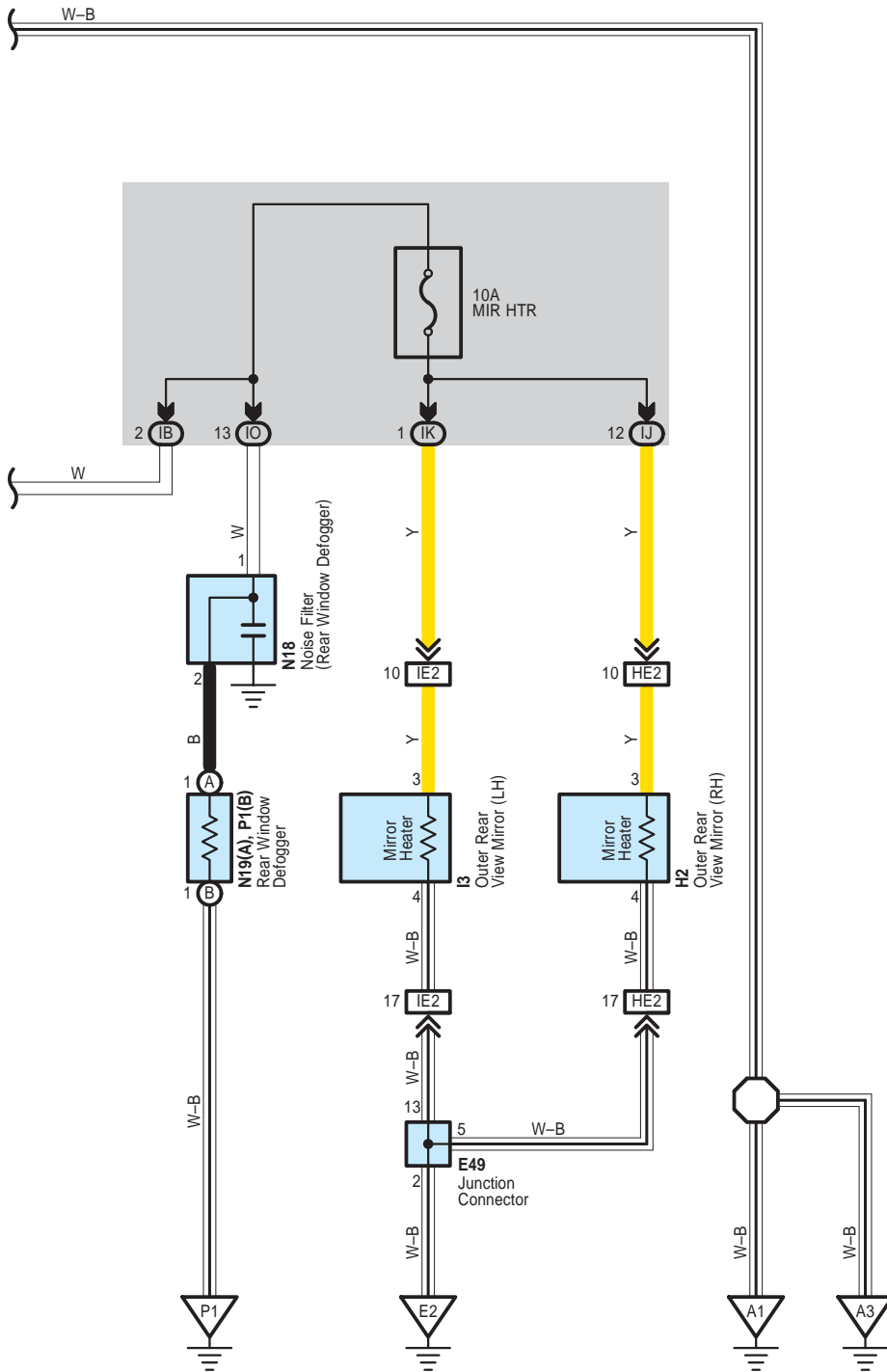

CAMRY (EM0250U)



# Rear Window Defogger and Mirror Heater

## ○ : Parts Location

| Code |   | See Page | Code |    | See Page | Code |    | See Page |
|------|---|----------|------|----|----------|------|----|----------|
| A41  | A | 59       | F16  | 58 | N19      | A    | 60 |          |
| A42  | B | 59       | H2   | 61 | P1       | B    | 60 |          |
| E38  | A | 57       | I3   | 61 |          |      |    |          |
| E49  |   | 57       | N18  | 60 |          |      |    |          |

## ○ : Relay Blocks

| Code | See Page | Relay Blocks (Relay Block Location)       |
|------|----------|---|
| 1    | 22       | Engine Room R/B (Engine Compartment Left) |

## ○ : Junction Block and Wire Harness Connector

| Code | See Page | Junction Block and Wire Harness (Connector Location)                   |
|------|----------|--|
| 3D   | 36       | Instrument Panel Wire and J/B No.3 (Behind the Combination Meter)      |
| 3L   |          |  |
| 3M   |          |  |
| 3S   | 36       | Instrument Panel No.2 Wire and J/B No.3 (Behind the Combination Meter) |
| 3U   |          |  |
| IB   | 30       | Engine Room Main Wire and Instrument Panel J/B (Cowl Side Left)        |
| ID   |          |  |
| IF   | 30       | Instrument Panel Wire and Instrument Panel J/B (Cowl Side Left)        |
| IJ   |          |  |
| IK   |          |  |
| IO   | 30       | Floor Wire and Instrument Panel J/B (Cowl Side Left)                   |

## □ : Connector Joining Wire Harness and Wire Harness

| Code | See Page | Joining Wire Harness and Wire Harness (Connector Location)        |
|------|----------|---|
| EA1  | 66       | Instrument Panel Wire and Engine Room Main Wire (Left Kick Panel) |
| HE2  | 66       | Front Door RH Wire and Instrument Panel Wire (Right Kick Panel)   |
| IE2  | 66       | Front Door LH Wire and Instrument Panel Wire (Left Kick Panel)    |

## ▽ : Ground Points

| Code | See Page    | Ground Points Location    |
|------|-------------|---------------------------|
| A1   | 64 (2GR-FE) | Front Left Fender         |
|      | 65 (2AZ-FE) |                           |
| E2   | 66          | Instrument Panel Brace LH |
| F1   | 66          | Instrument Panel Left     |
| P1   | 67          | Right Rear Quarter Panel  |



# Navigation System and Audio System with 8 Speaker

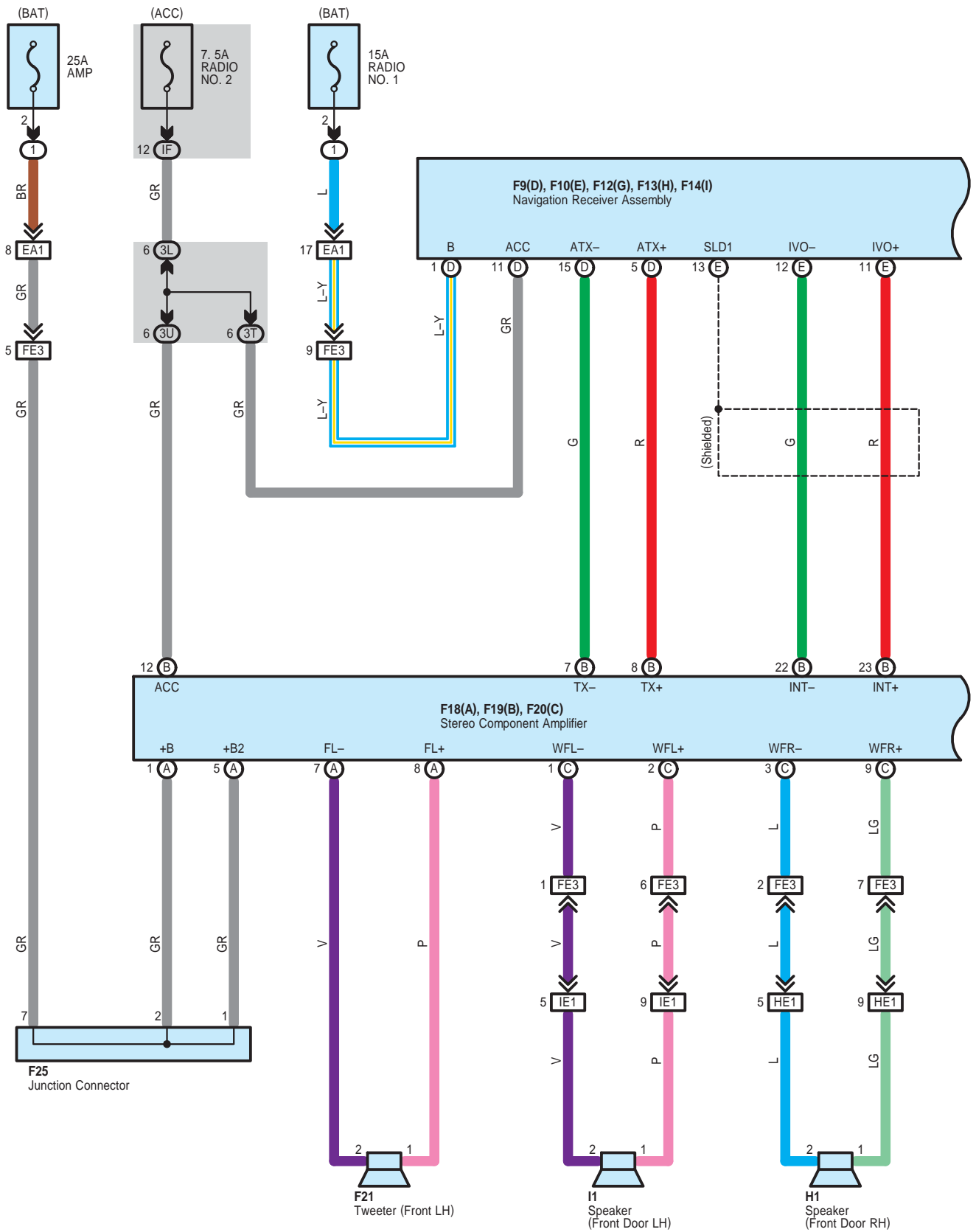

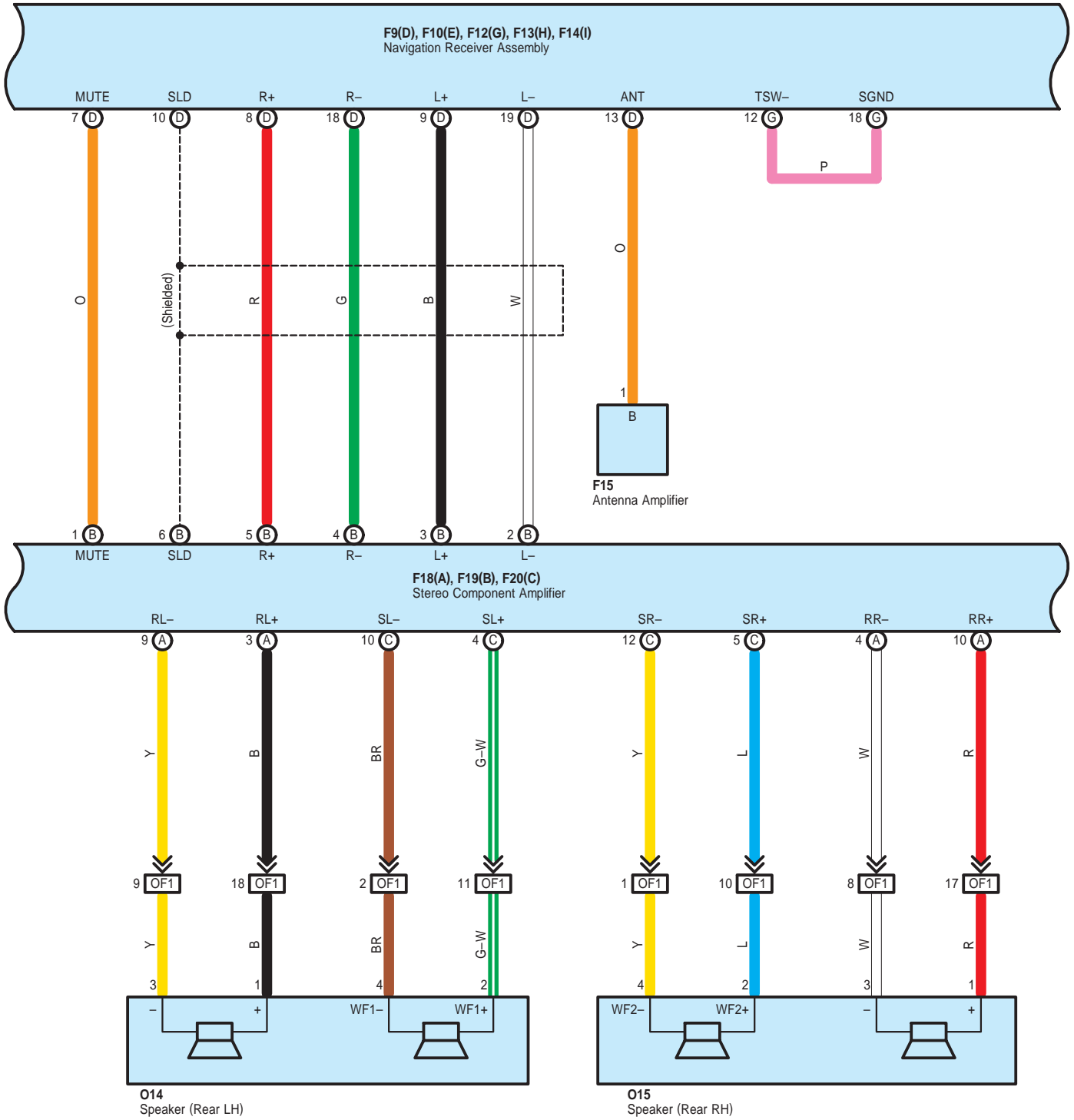

# Navigation System and Audio System with 8 Speaker

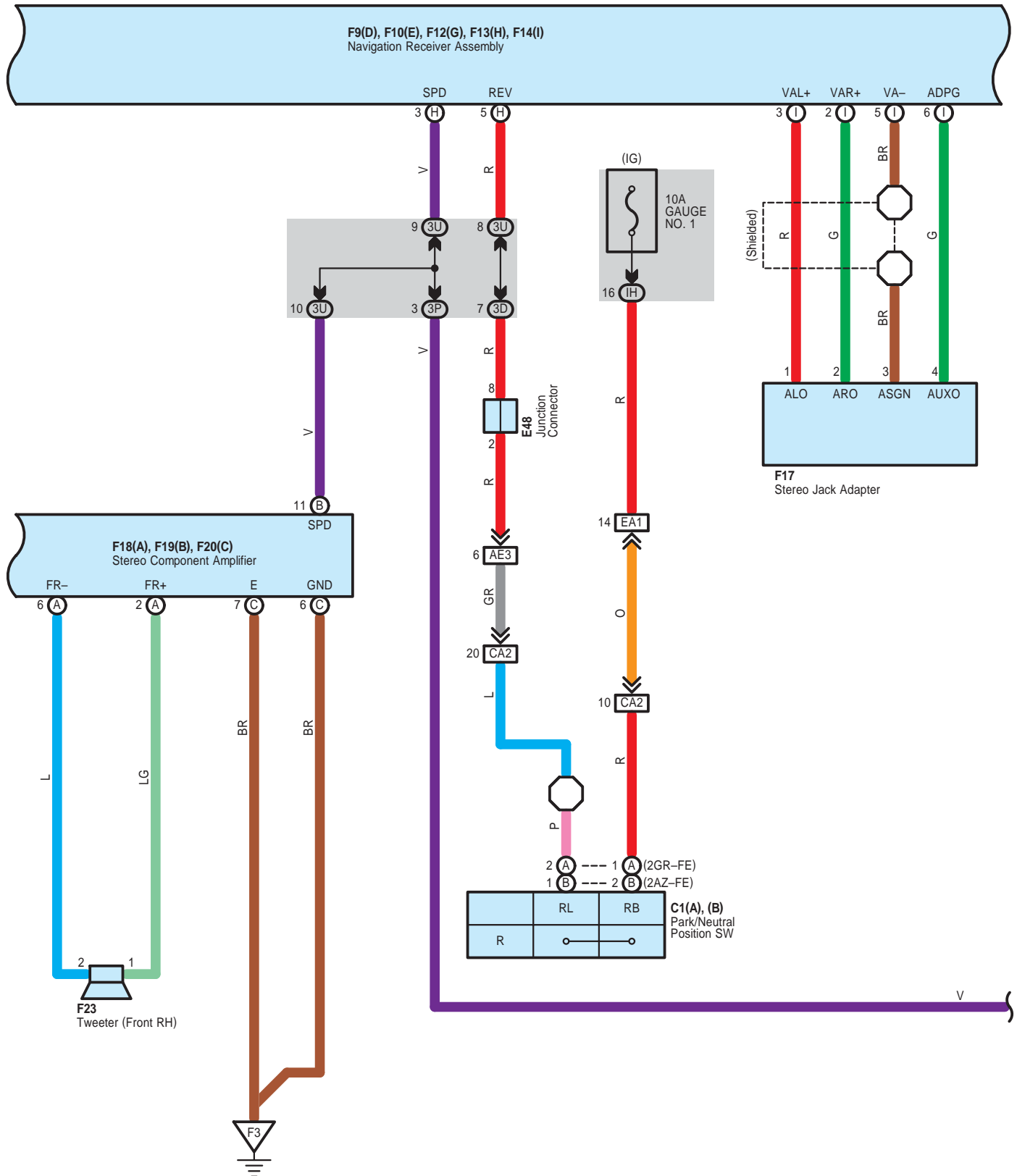

\* 1 : TMC Made  
 \* 2 : TMMK Made

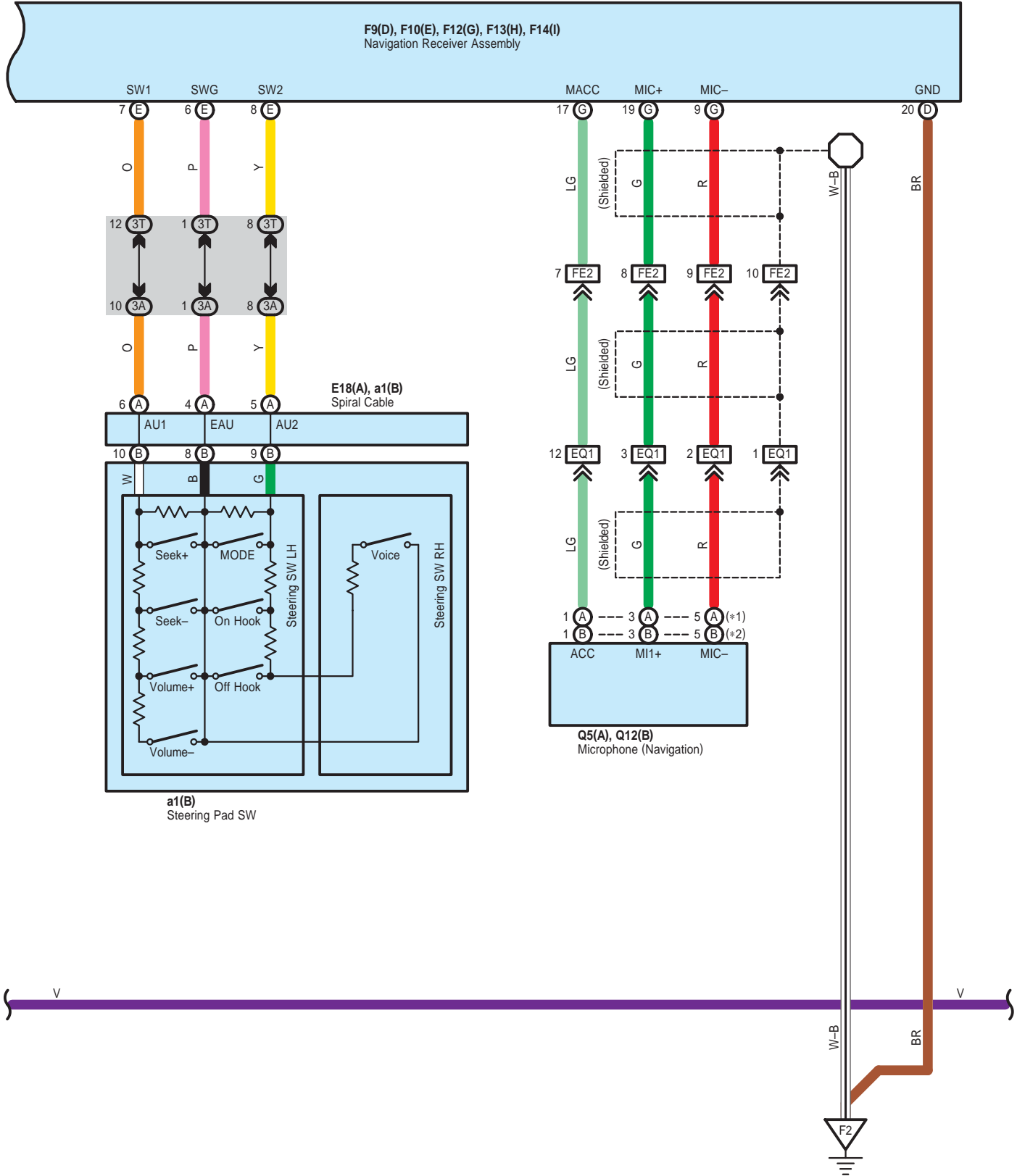

# Navigation System and Audio System with 8 Speaker

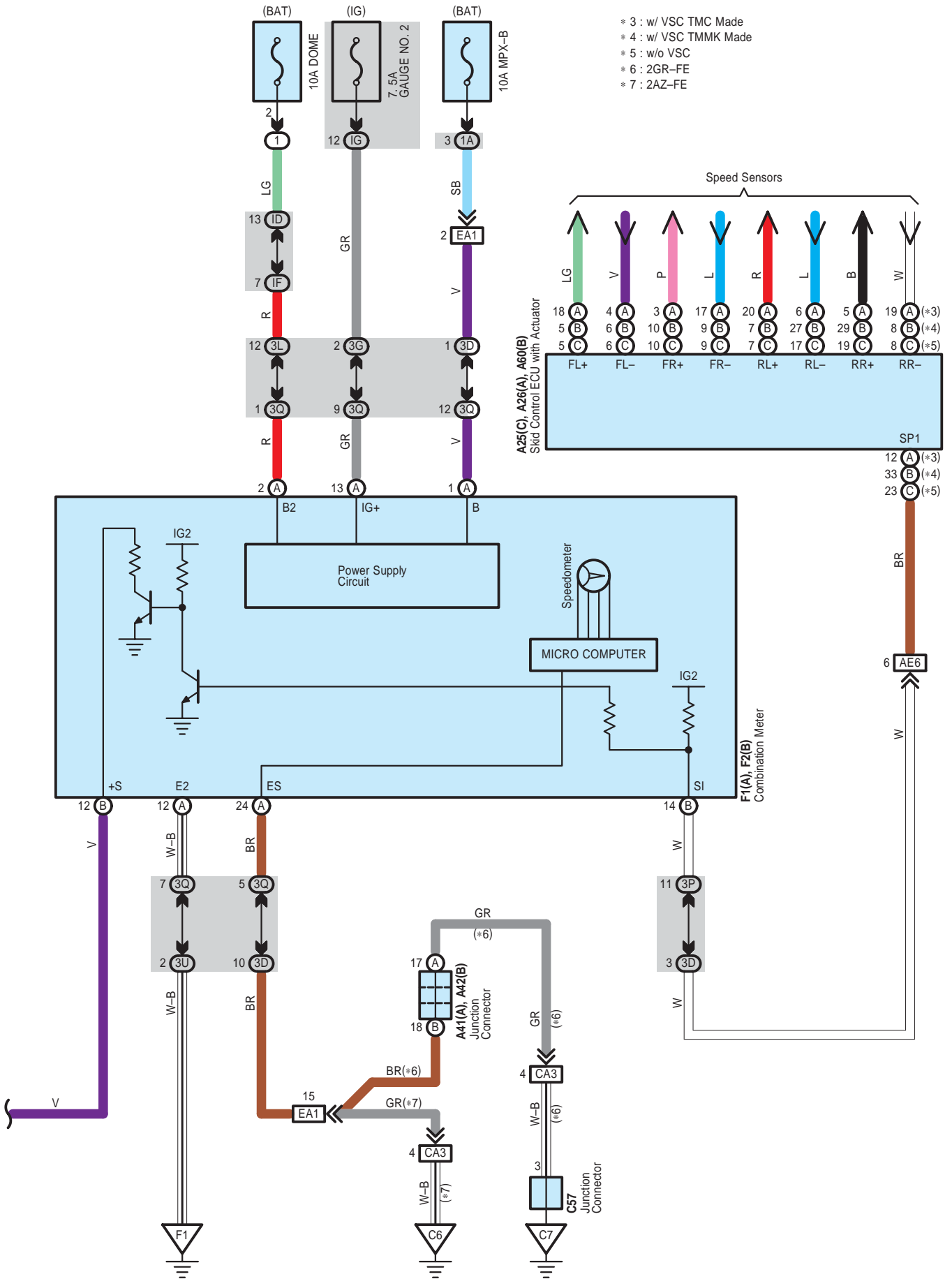

**○ : Parts Location**

| Code | See Page | Code        | See Page | Code | See Page     |
|------|----------|-------------|----------|------|--------------|
| A25  | C        | 48 (2GR-FE) | E48      | 57   | F20   C   58 |
|      |          | 52 (2AZ-FE) | F1   A   | 58   | F21   58     |
| A26  | A        | 48 (2GR-FE) | F2   B   | 58   | F23   58     |
|      |          | 52 (2AZ-FE) | F9   D   | 58   | F25   58     |
| A41  | A        | 59          | F10   E  | 58   | H1   61      |
| A42  | B        | 59          | F12   G  | 58   | I1   61      |
| A60  | B        | 49 (2GR-FE) | F13   H  | 58   | O14   60     |
|      |          | 53 (2AZ-FE) | F14   I  | 58   | O15   60     |
| C1   | A        | 50 (2GR-FE) | F15      | 58   | Q5   A   61  |
|      | B        | 54 (2AZ-FE) | F17      | 58   | Q12   B   61 |
| C57  |          | 51 (2GR-FE) | F18   A  | 58   | a1   B   59  |
| E18  | A        | 56          | F19   B  | 58   |              |

**○ : Relay Blocks**

| Code | See Page | Relay Blocks (Relay Block Location)       |
|------|----------|---|
| 1    | 22       | Engine Room R/B (Engine Compartment Left) |

**○ : Junction Block and Wire Harness Connector**

| Code | See Page | Junction Block and Wire Harness (Connector Location)                   |
|------|----------|--|
| 1A   | 25       | Engine Room Main Wire and Engine Room J/B (Engine Compartment Left)    |
| 3A   | 36       | Instrument Panel Wire and J/B No.3 (Behind the Combination Meter)      |
| 3D   |          |  |
| 3G   |          |  |
| 3L   |          |  |
| 3P   |          |  |
| 3Q   | 36       | Instrument Panel No.2 Wire and J/B No.3 (Behind the Combination Meter) |
| 3T   |          |  |
| 3U   |          |  |
| ID   | 30       | Engine Room Main Wire and Instrument Panel J/B (Cowl Side Left)        |
| IF   | 30       | Instrument Panel Wire and Instrument Panel J/B (Cowl Side Left)        |
| IG   | 31       |  |
| IH   |          |  |

**□ : Connector Joining Wire Harness and Wire Harness**

| Code | See Page    | Joining Wire Harness and Wire Harness (Connector Location)                                |
|------|-------------|---|
| AE3  | 66          | Engine Room Main Wire and Instrument Panel Wire (Instrument Panel Right)                  |
| AE6  |             |   |
| CA2  | 64 (2GR-FE) | Engine Wire and Engine Room Main Wire (Inside of the Engine Room R/B and Engine Room J/B) |
|      | 65 (2AZ-FE) |   |
| CA3  | 64 (2GR-FE) |   |
|      | 65 (2AZ-FE) |   |
| EA1  | 66          | Instrument Panel Wire and Engine Room Main Wire (Left Kick Panel)                         |
| EQ1  | 66          | Instrument Panel Wire and Roof Wire (Lower Part of Front Pillar LH)                       |
| FE2  | 66          | Instrument Panel No.2 Wire and Instrument Panel Wire (Instrument Panel Center)            |
| FE3  |             |   |
| HE1  | 66          | Front Door RH Wire and Instrument Panel Wire (Right Kick Panel)                           |
| IE1  | 66          | Front Door LH Wire and Instrument Panel Wire (Left Kick Panel)                            |
| OF1  | 66          | Floor No.2 Wire and Instrument Panel No.2 Wire (Instrument Panel Right)                   |



## Navigation System and Audio System with 8 Speaker

---



: Ground Points

| Code | See Page    | Ground Points Location           |
|------|-------------|----------------------------------|
| C6   | 65 (2AZ-FE) | Cylinder Block                   |
| C7   | 64 (2GR-FE) | Left Side of the Cylinder Block  |
| F1   | 66          | Instrument Panel Left            |
| F2   | 66          | Instrument Panel Brace RH        |
| F3   | 66          | Under the Front Passenger's Seat |



# Audio System with 8 Speaker without Navigation

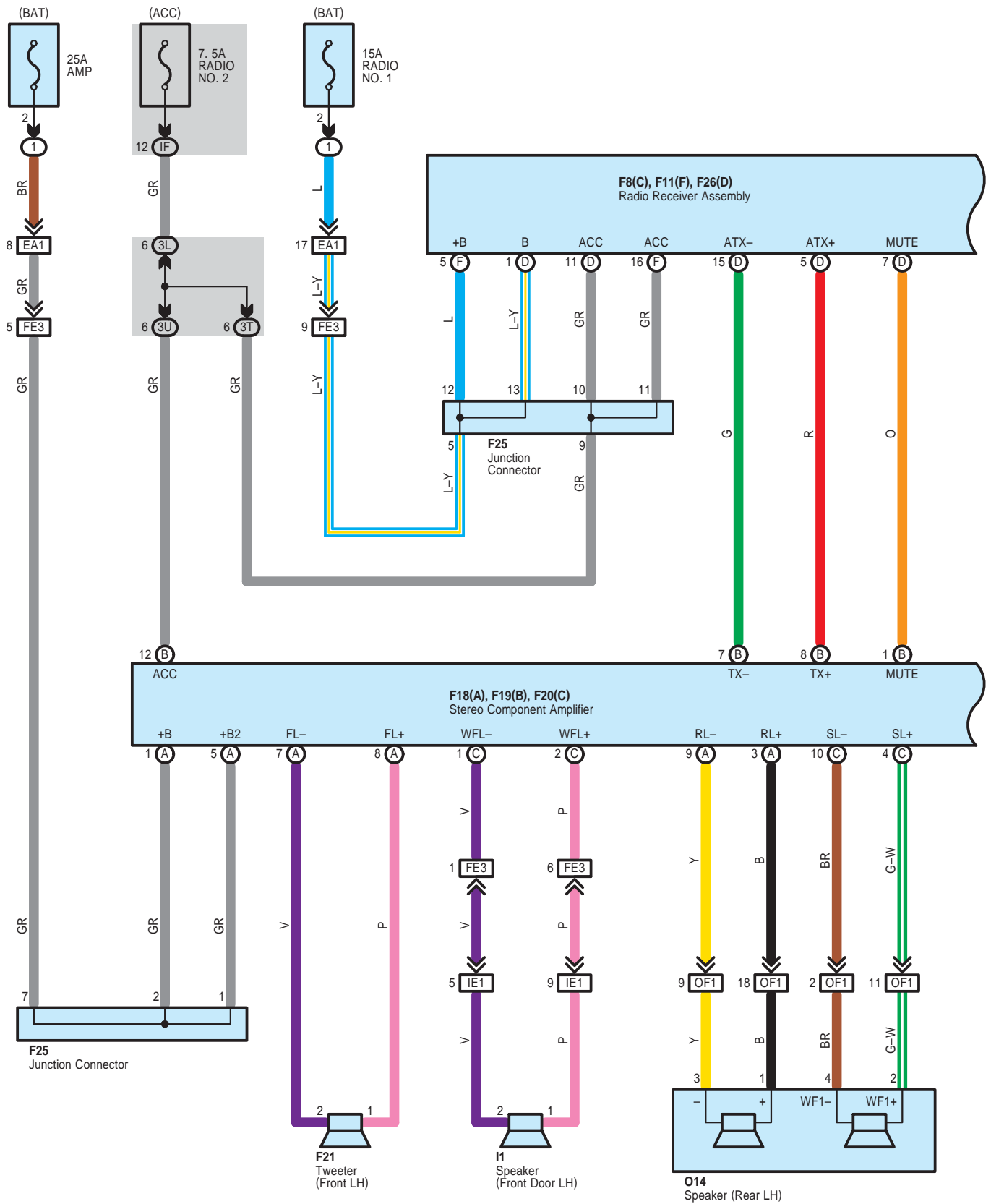

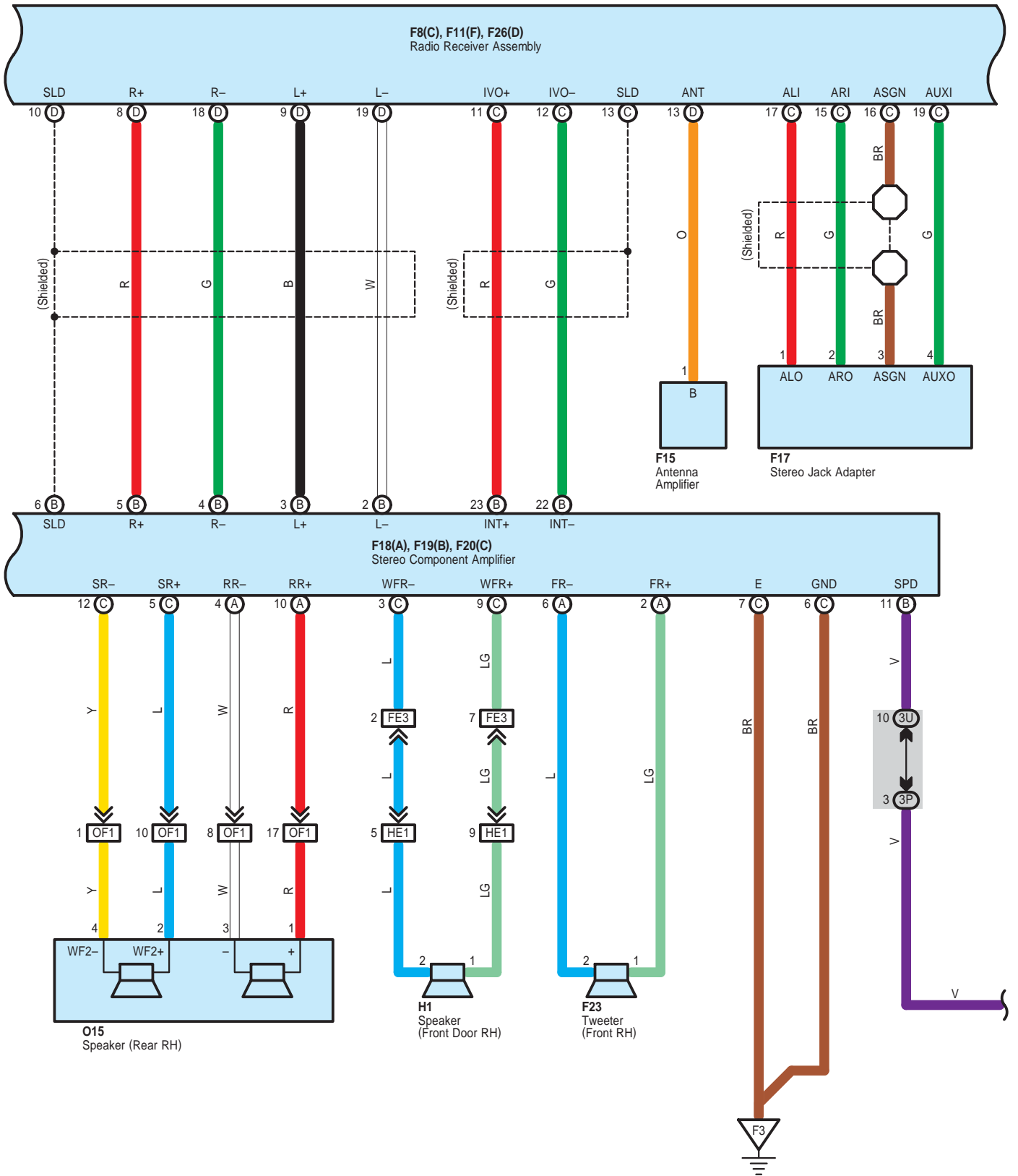

# Audio System with 8 Speaker without Navigation

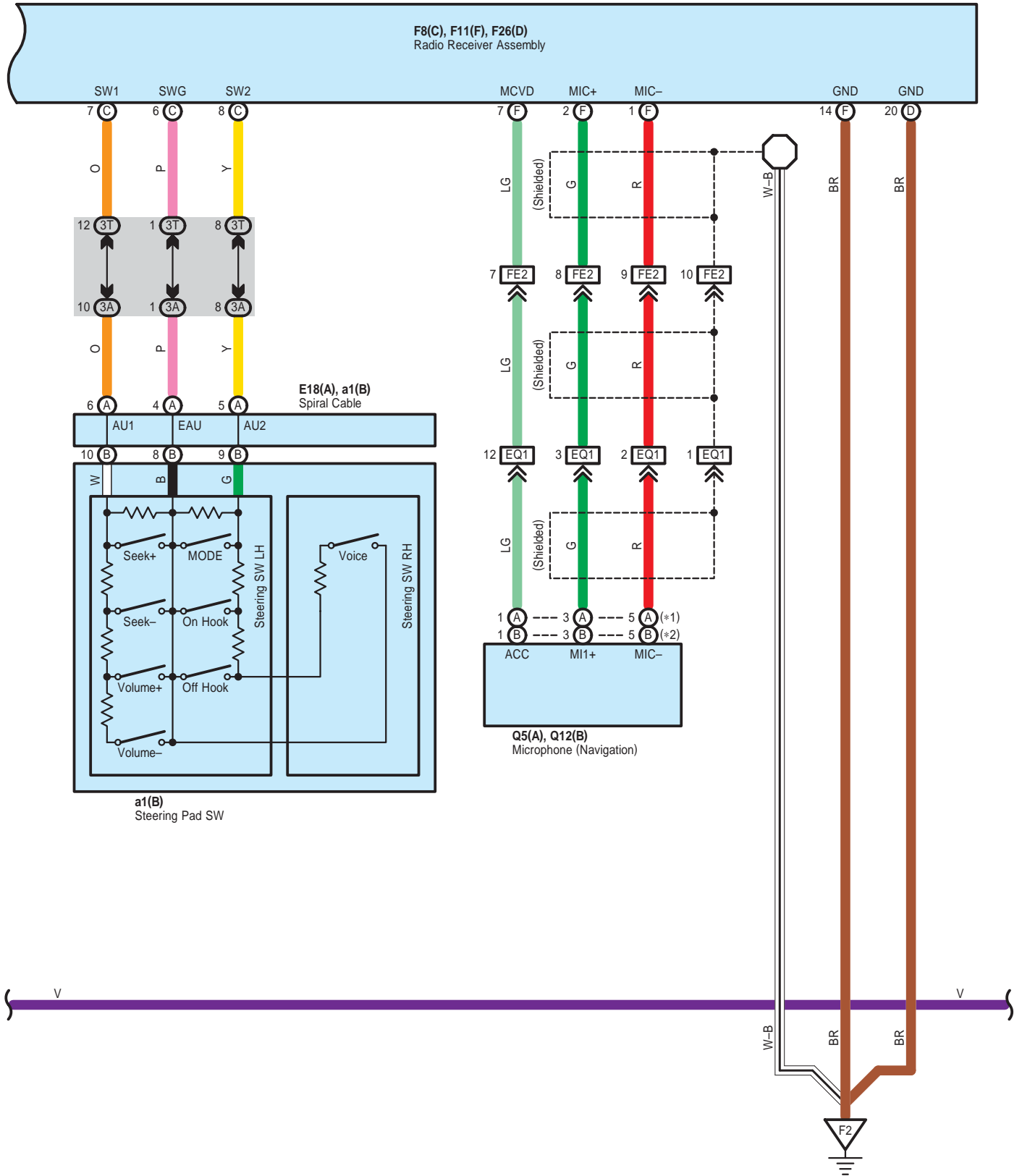

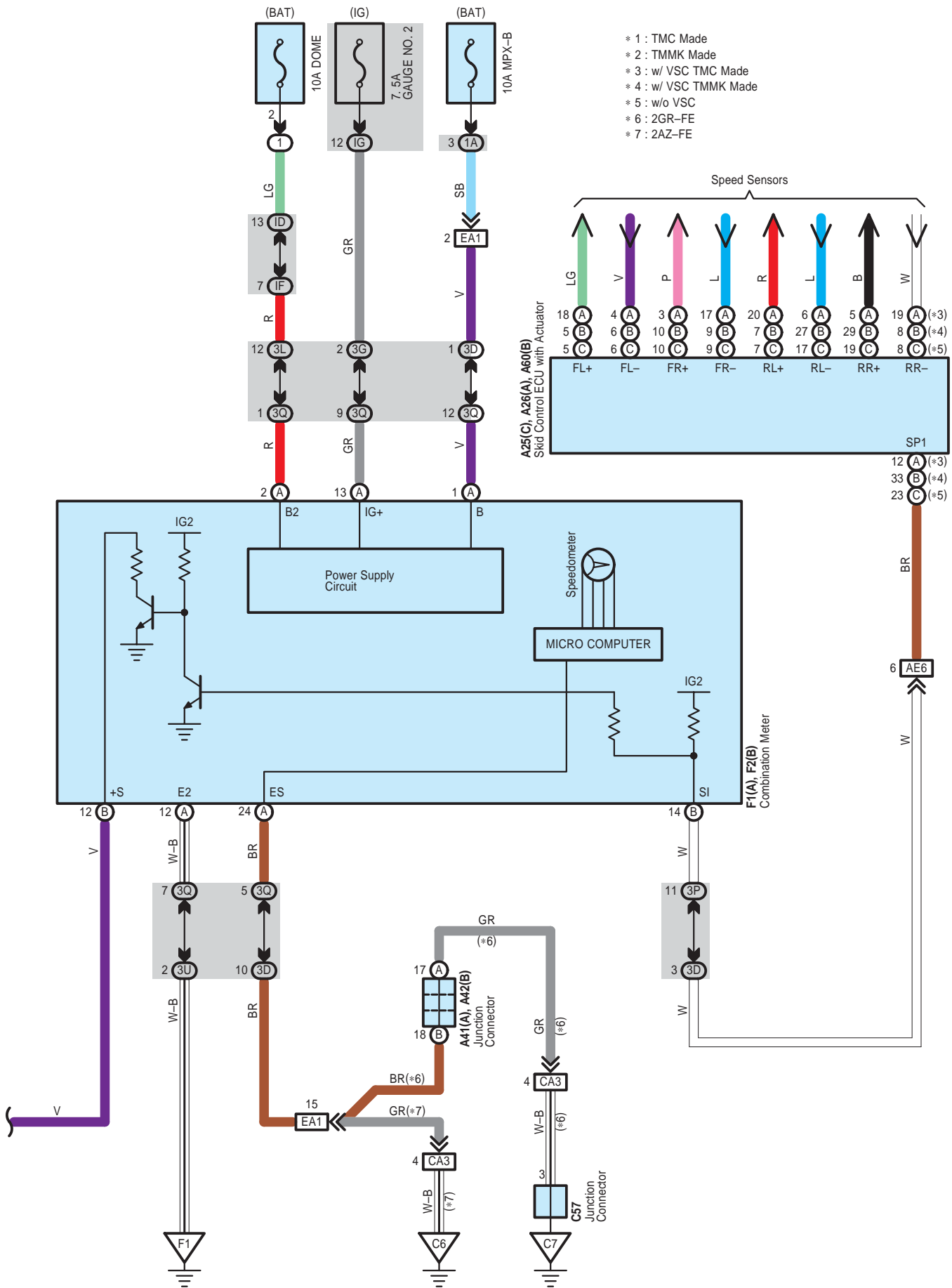

CAMRY (EM0250U)

# Audio System with 8 Speaker without Navigation

## ○ : Parts Location

| Code | See Page | Code        | See Page | Code | See Page |
|------|----------|-------------|----------|------|----------|
| A25  | C        | 48 (2GR-FE) | F1 A     | 58   | F23 58   |
|      |          | 52 (2AZ-FE) | F2 B     | 58   | F25 58   |
| A26  | A        | 48 (2GR-FE) | F8 C     | 58   | F26 D 58 |
|      |          | 52 (2AZ-FE) | F11 F    | 58   | H1 61    |
| A41  | A        | 59          | F15      | 58   | I1 61    |
| A42  | B        | 59          | F17      | 58   | O14 60   |
| A60  | B        | 49 (2GR-FE) | F18 A    | 58   | O15 60   |
|      |          | 53 (2AZ-FE) | F19 B    | 58   | Q5 A 61  |
| C57  |          | 51 (2GR-FE) | F20 C    | 58   | Q12 B 61 |
| E18  | A        | 56          | F21      | 58   | a1 B 59  |

## ○ : Relay Blocks

| Code | See Page | Relay Blocks (Relay Block Location)       |
|------|----------|---|
| 1    | 22       | Engine Room R/B (Engine Compartment Left) |

## ○ : Junction Block and Wire Harness Connector

| Code | See Page | Junction Block and Wire Harness (Connector Location)                   |
|------|----------|--|
| 1A   | 25       | Engine Room Main Wire and Engine Room J/B (Engine Compartment Left)    |
| 3A   | 36       | Instrument Panel Wire and J/B No.3 (Behind the Combination Meter)      |
| 3D   |          |  |
| 3G   |          |  |
| 3L   |          |  |
| 3P   | 36       | Instrument Panel No.2 Wire and J/B No.3 (Behind the Combination Meter) |
| 3Q   |          |  |
| 3T   |          |  |
| 3U   |          |  |
| ID   | 30       | Engine Room Main Wire and Instrument Panel J/B (Cowl Side Left)        |
| IF   | 30       | Instrument Panel Wire and Instrument Panel J/B (Cowl Side Left)        |
| IG   | 31       |  |

## □ : Connector Joining Wire Harness and Wire Harness

| Code | See Page    | Joining Wire Harness and Wire Harness (Connector Location)                                |
|------|-------------|---|
| AE6  | 66          | Engine Room Main Wire and Instrument Panel Wire (Instrument Panel Right)                  |
| CA3  | 64 (2GR-FE) | Engine Wire and Engine Room Main Wire (Inside of the Engine Room R/B and Engine Room J/B) |
|      | 65 (2AZ-FE) |   |
| EA1  | 66          | Instrument Panel Wire and Engine Room Main Wire (Left Kick Panel)                         |
| EQ1  | 66          | Instrument Panel Wire and Roof Wire (Lower Part of Front Pillar LH)                       |
| FE2  | 66          | Instrument Panel No.2 Wire and Instrument Panel Wire (Instrument Panel Center)            |
| FE3  |             |   |
| HE1  | 66          | Front Door RH Wire and Instrument Panel Wire (Right Kick Panel)                           |
| IE1  | 66          | Front Door LH Wire and Instrument Panel Wire (Left Kick Panel)                            |
| OF1  | 66          | Floor No.2 Wire and Instrument Panel No.2 Wire (Instrument Panel Right)                   |

## ▽ : Ground Points

| Code | See Page    | Ground Points Location           |
|------|-------------|----------------------------------|
| C6   | 65 (2AZ-FE) | Cylinder Block                   |
| C7   | 64 (2GR-FE) | Left Side of the Cylinder Block  |
| F1   | 66          | Instrument Panel Left            |
| F2   | 66          | Instrument Panel Brace RH        |
| F3   | 66          | Under the Front Passenger's Seat |





# Audio System with 6 Speaker

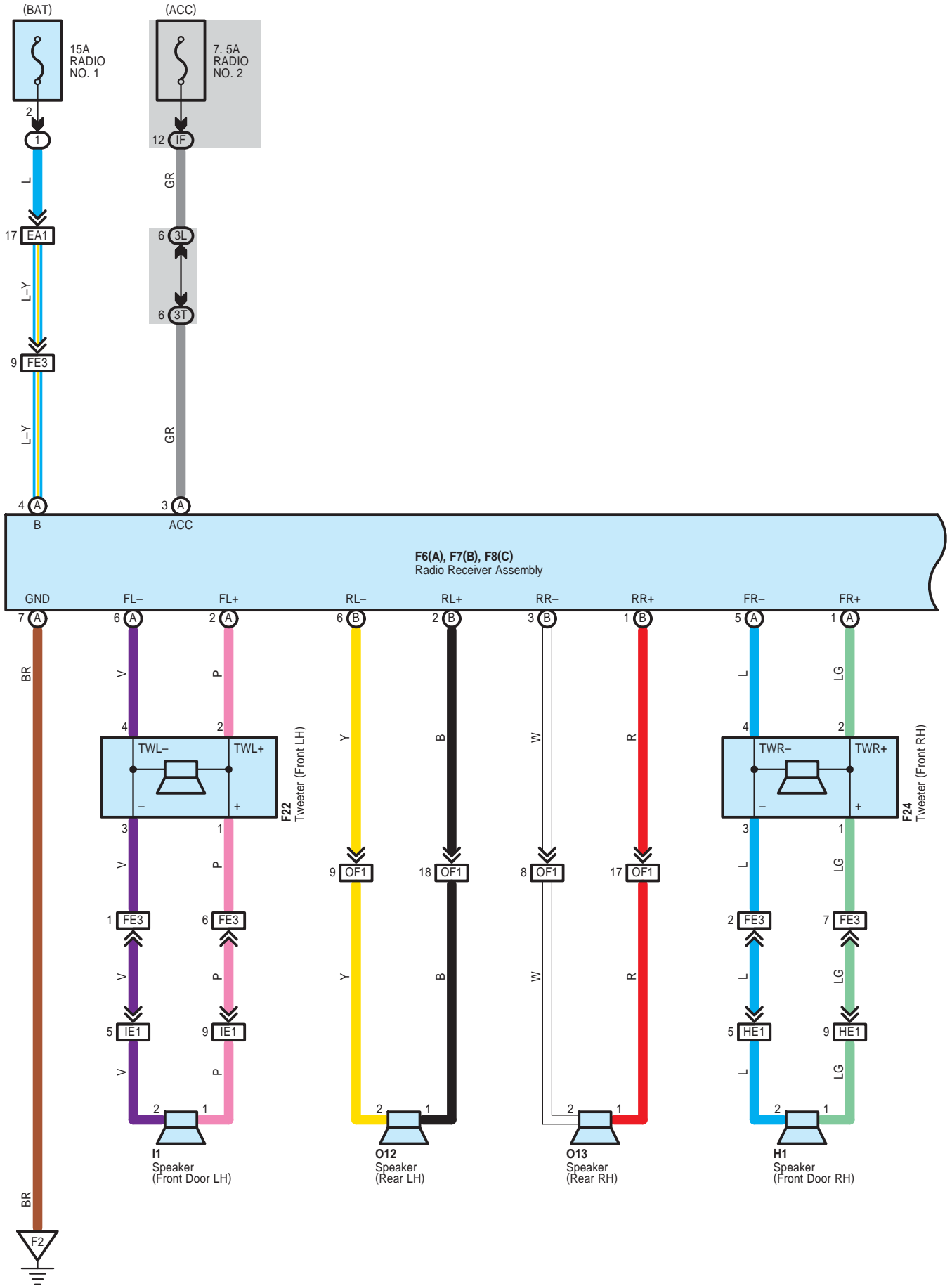

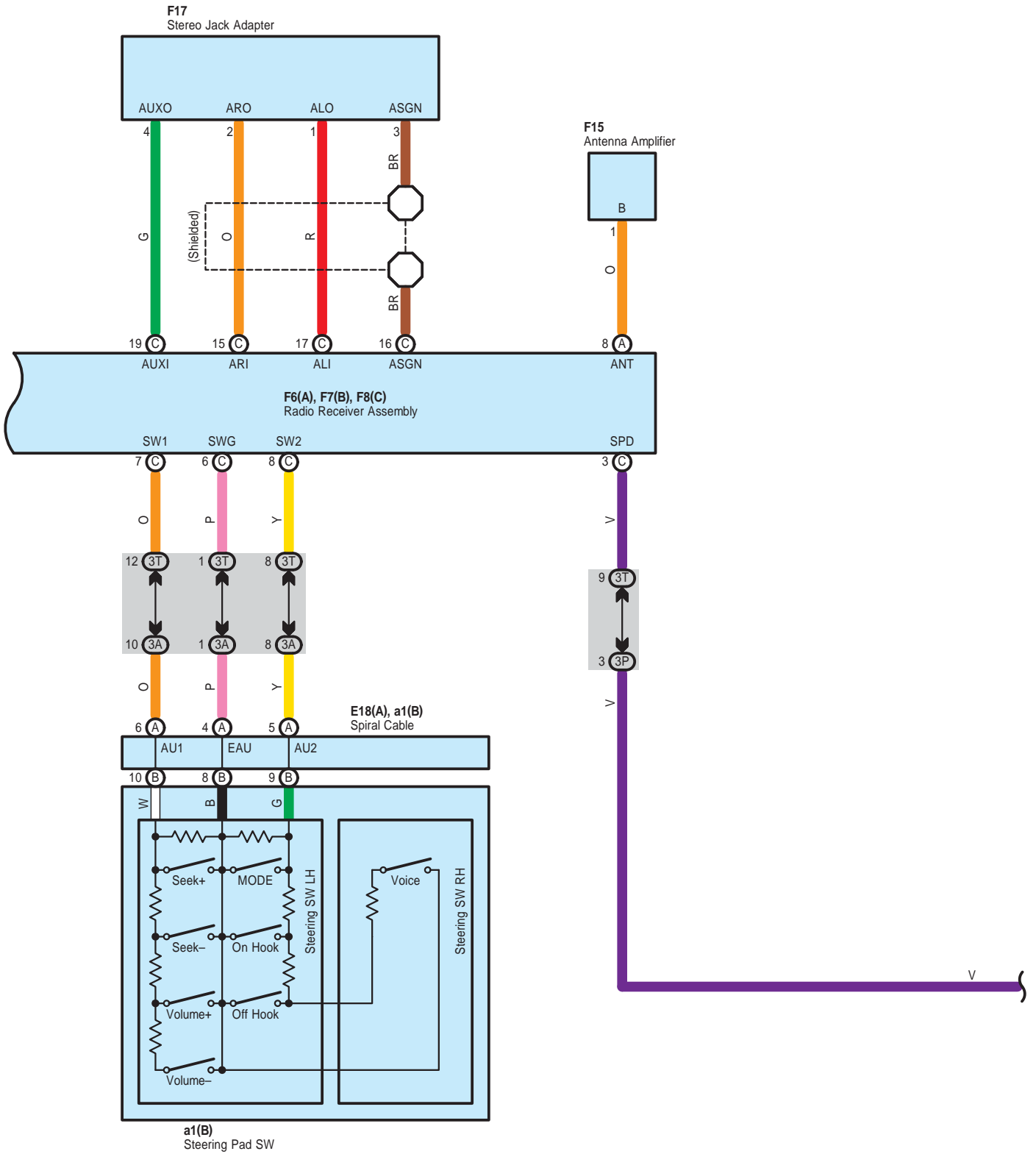

# Audio System with 6 Speaker

- \* 1 : 2GR-FE
- \* 2 : 2AZ-FE
- \* 3 : w/ VSC TMC Made
- \* 4 : w/ VSC TMMK Made
- \* 5 : w/o VSC

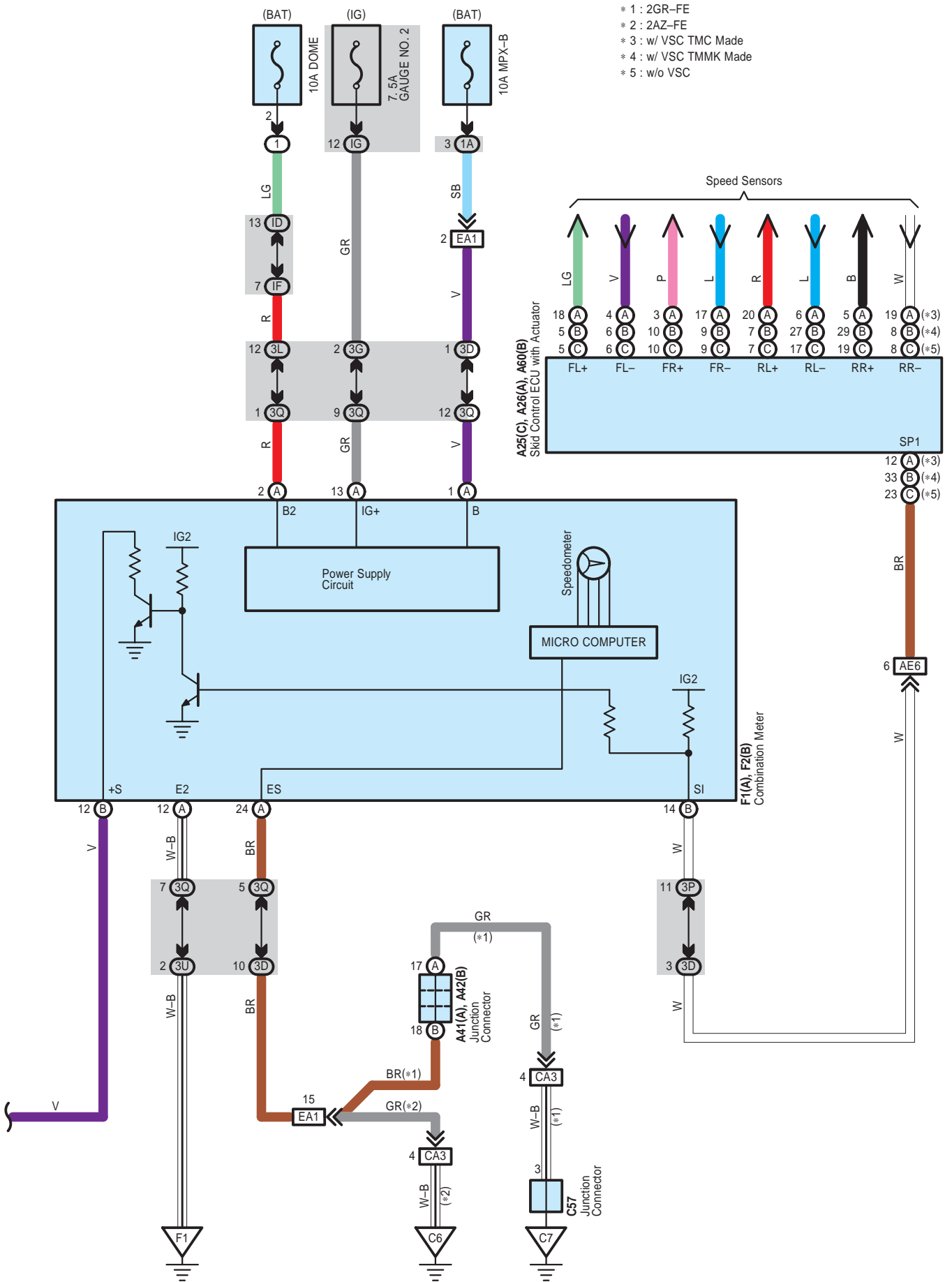

 : Parts Location

| Code | See Page | Code        | See Page | Code        | See Page |
|------|----------|-------------|----------|-------------|----------|
| A25  | C        | 48 (2GR-FE) | C57      | 51 (2GR-FE) | F17 58   |
|      |          | 52 (2AZ-FE) | E18 A    | 56          | F22 58   |
| A26  | A        | 48 (2GR-FE) | F1 A     | 58          | F24 58   |
|      |          | 52 (2AZ-FE) | F2 B     | 58          | H1 61    |
| A41  | A        | 59          | F6 A     | 58          | I1 61    |
| A42  | B        | 59          | F7 B     | 58          | O12 60   |
| A60  | B        | 49 (2GR-FE) | F8 C     | 58          | O13 60   |
|      |          | 53 (2AZ-FE) | F15      | 58          | a1 B 59  |

 : Relay Blocks

| Code | See Page | Relay Blocks (Relay Block Location)       |
|------|----------|---|
| 1    | 22       | Engine Room R/B (Engine Compartment Left) |

 : Junction Block and Wire Harness Connector

| Code | See Page | Junction Block and Wire Harness (Connector Location)                   |
|------|----------|--|
| 1A   | 25       | Engine Room Main Wire and Engine Room J/B (Engine Compartment Left)    |
| 3A   | 36       | Instrument Panel Wire and J/B No.3 (Behind the Combination Meter)      |
| 3D   |          |  |
| 3G   |          |  |
| 3L   |          |  |
| 3P   | 36       | Instrument Panel No.2 Wire and J/B No.3 (Behind the Combination Meter) |
| 3Q   |          |  |
| 3T   |          |  |
| 3U   |          |  |
| ID   | 30       | Engine Room Main Wire and Instrument Panel J/B (Cowl Side Left)        |
| IF   | 30       | Instrument Panel Wire and Instrument Panel J/B (Cowl Side Left)        |
| IG   | 31       |  |

 : Connector Joining Wire Harness and Wire Harness

| Code | See Page    | Joining Wire Harness and Wire Harness (Connector Location)                                |
|------|-------------|---|
| AE6  | 66          | Engine Room Main Wire and Instrument Panel Wire (Instrument Panel Right)                  |
| CA3  | 64 (2GR-FE) | Engine Wire and Engine Room Main Wire (Inside of the Engine Room R/B and Engine Room J/B) |
|      | 65 (2AZ-FE) |   |
| EA1  | 66          | Instrument Panel Wire and Engine Room Main Wire (Left Kick Panel)                         |
| FE3  | 66          | Instrument Panel No.2 Wire and Instrument Panel Wire (Instrument Panel Center)            |
| HE1  | 66          | Front Door RH Wire and Instrument Panel Wire (Right Kick Panel)                           |
| IE1  | 66          | Front Door LH Wire and Instrument Panel Wire (Left Kick Panel)                            |
| OF1  | 66          | Floor No.2 Wire and Instrument Panel No.2 Wire (Instrument Panel Right)                   |

 : Ground Points

| Code | See Page    | Ground Points Location          |
|------|-------------|---------------------------------|
| C6   | 65 (2AZ-FE) | Cylinder Block                  |
| C7   | 64 (2GR-FE) | Left Side of the Cylinder Block |
| F1   | 66          | Instrument Panel Left           |
| F2   | 66          | Instrument Panel Brace RH       |

# Combination Meter

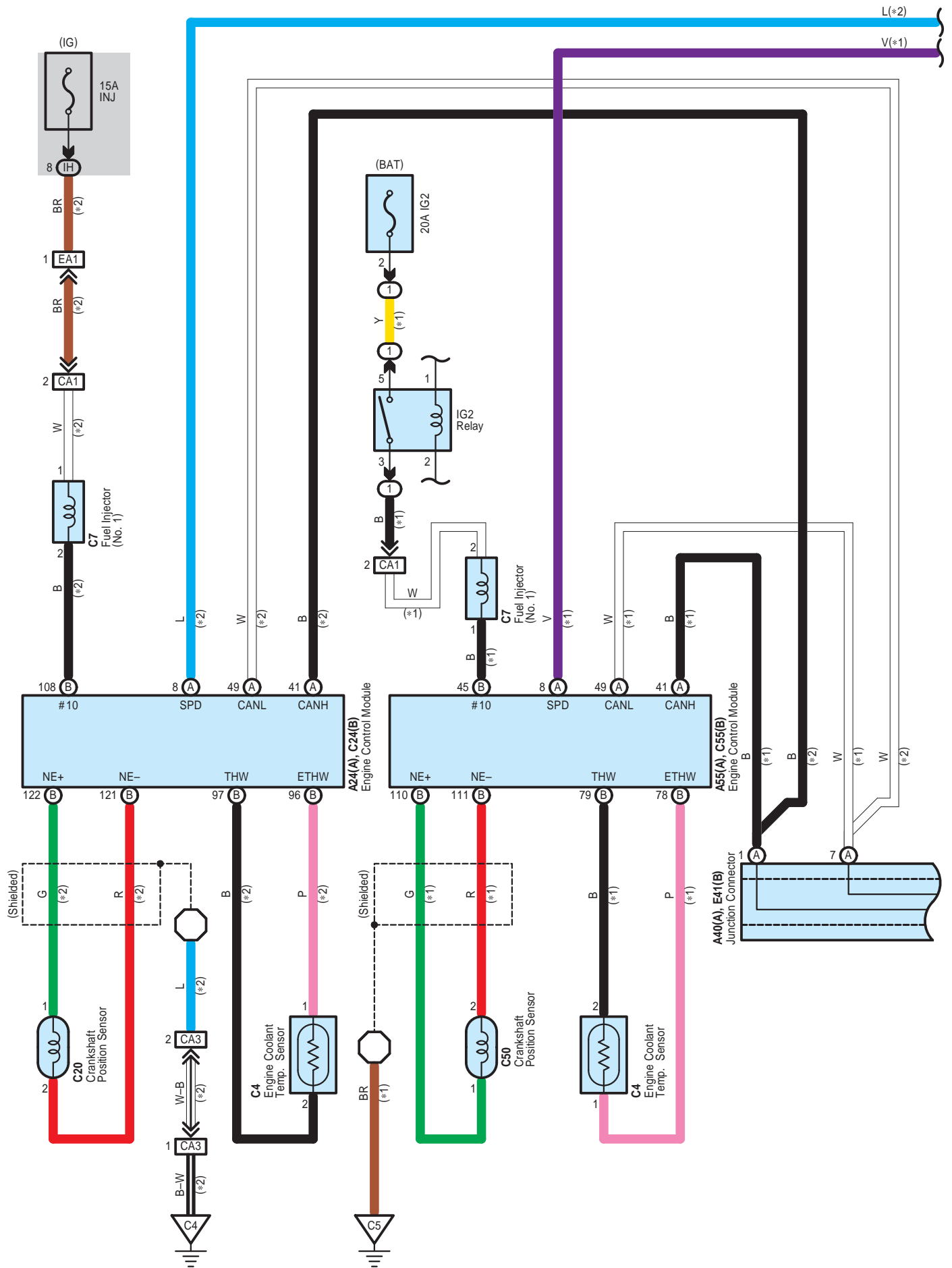



- \* 1 : 2GR-FE
- \* 2 : 2AZ-FE
- \* 3 : w/ VSC TMC Made
- \* 4 : w/ VSC TMMK Made
- \* 5 : w/o VSC

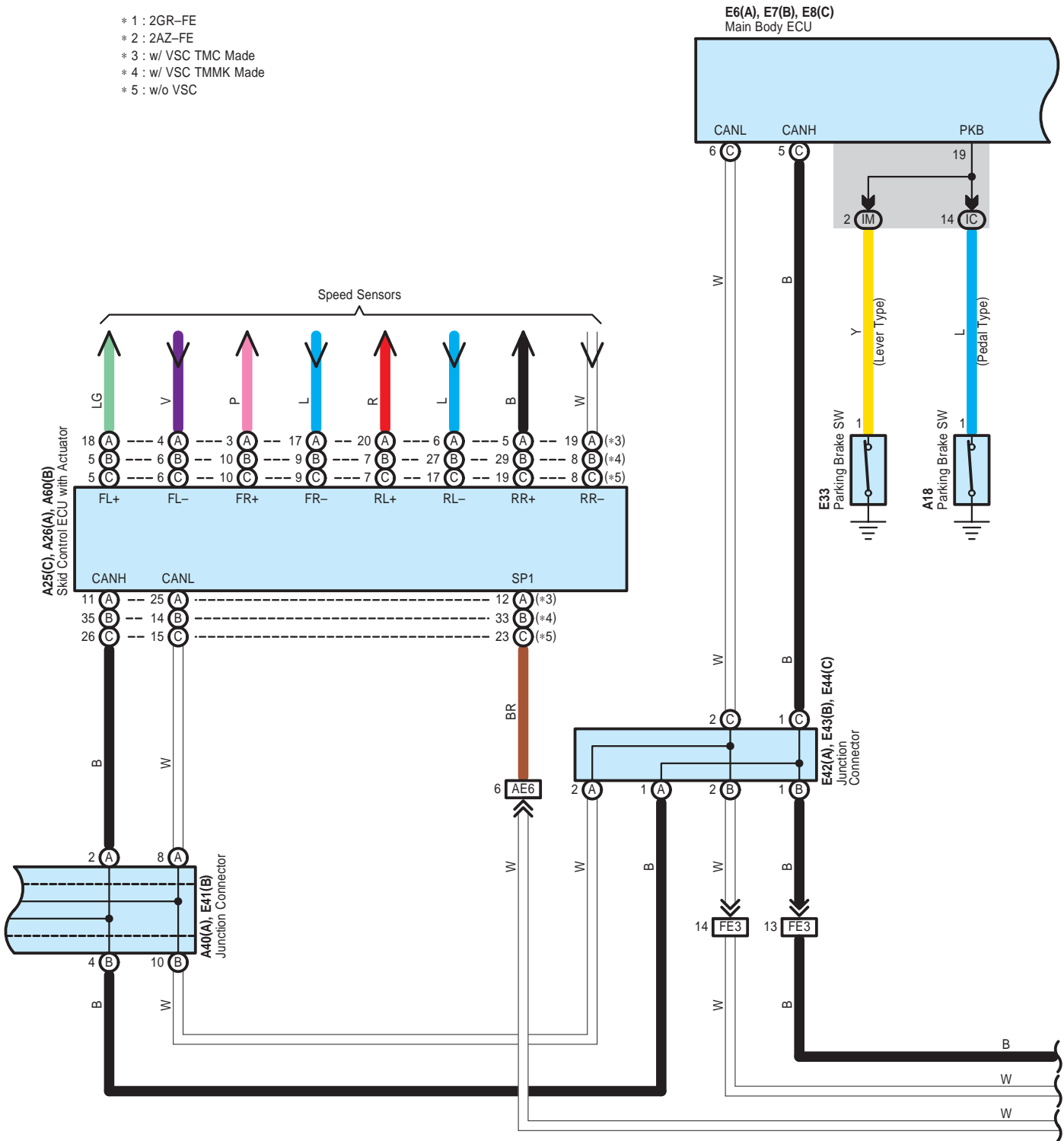

# Combination Meter

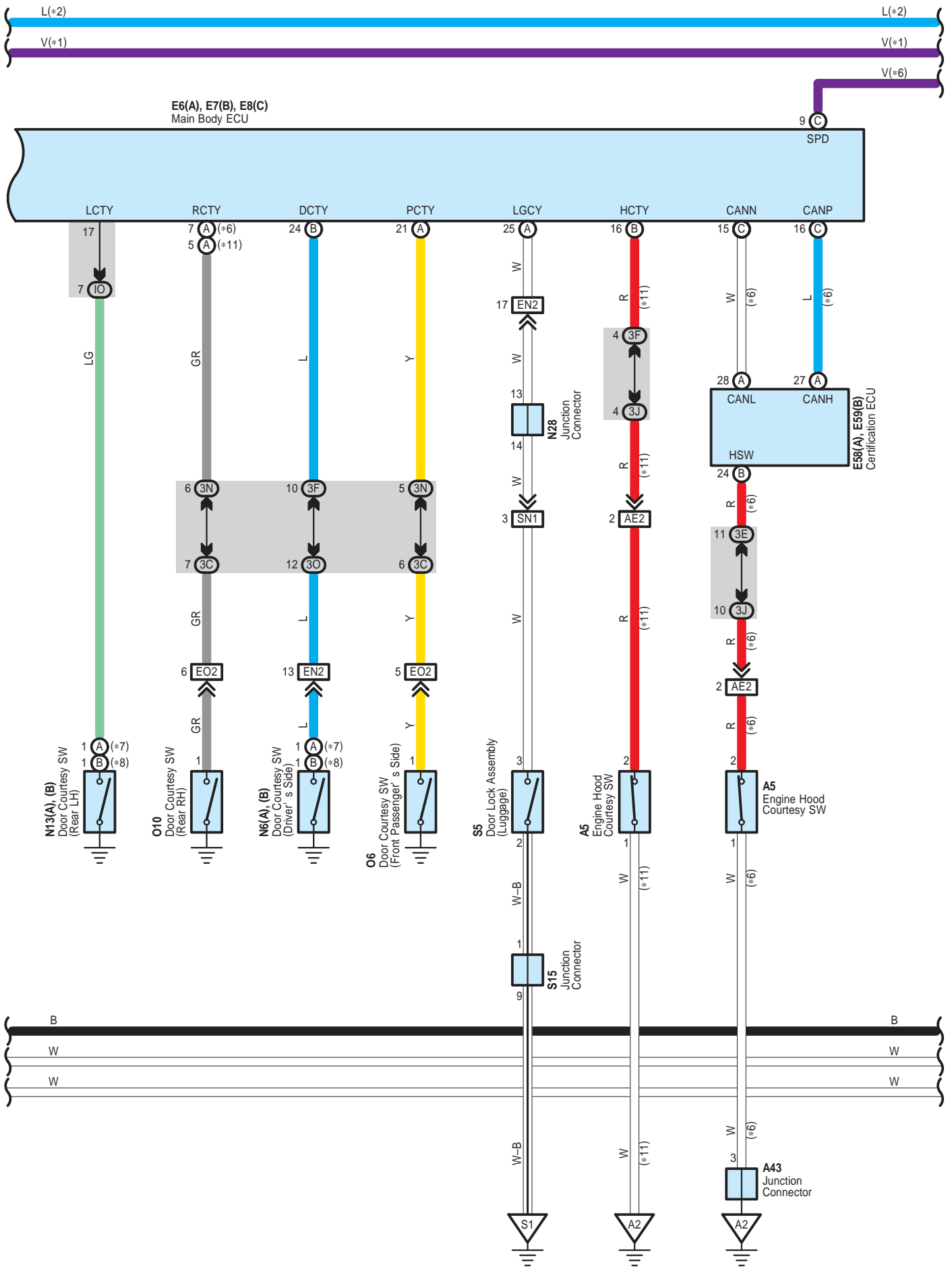

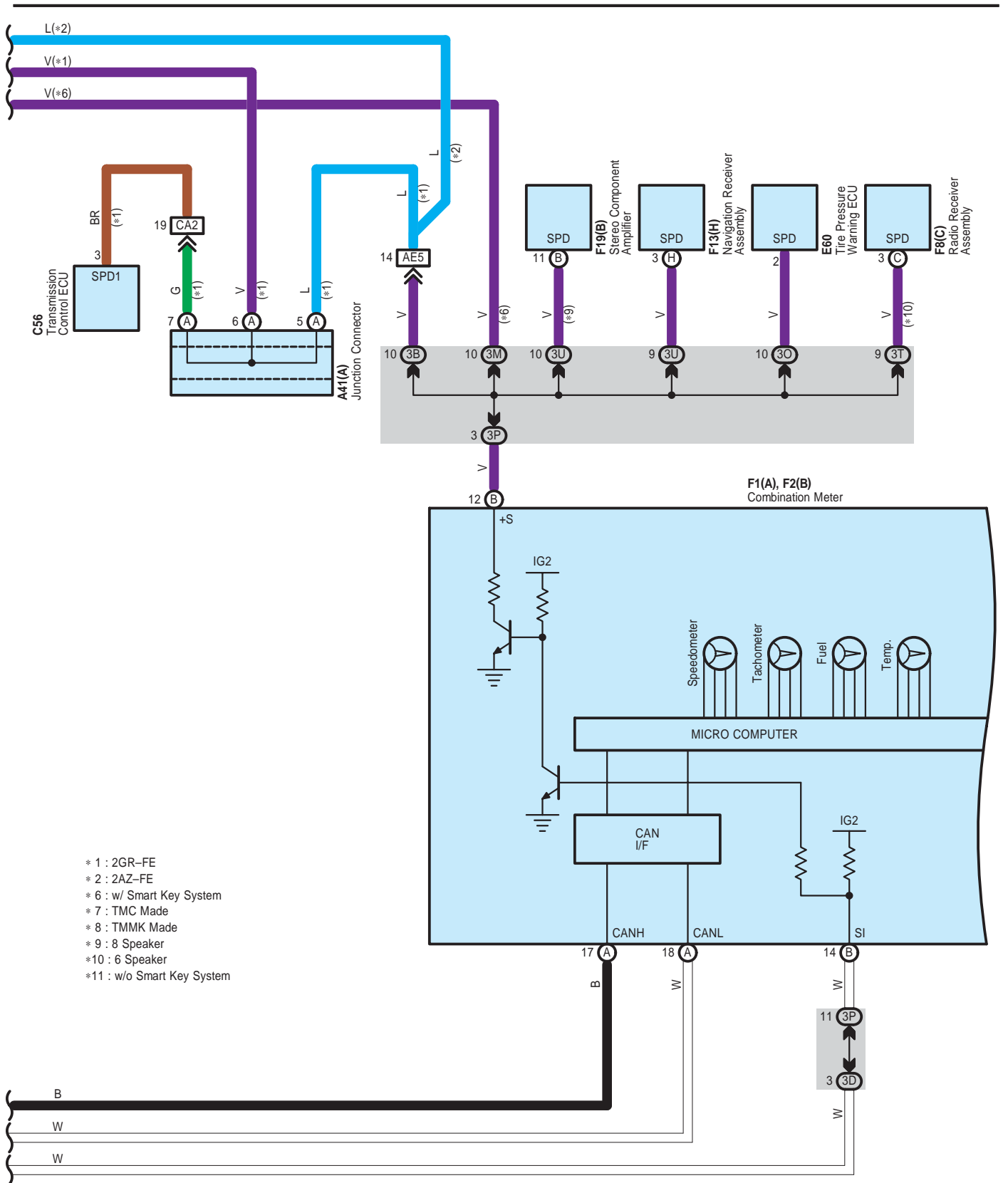



# Combination Meter

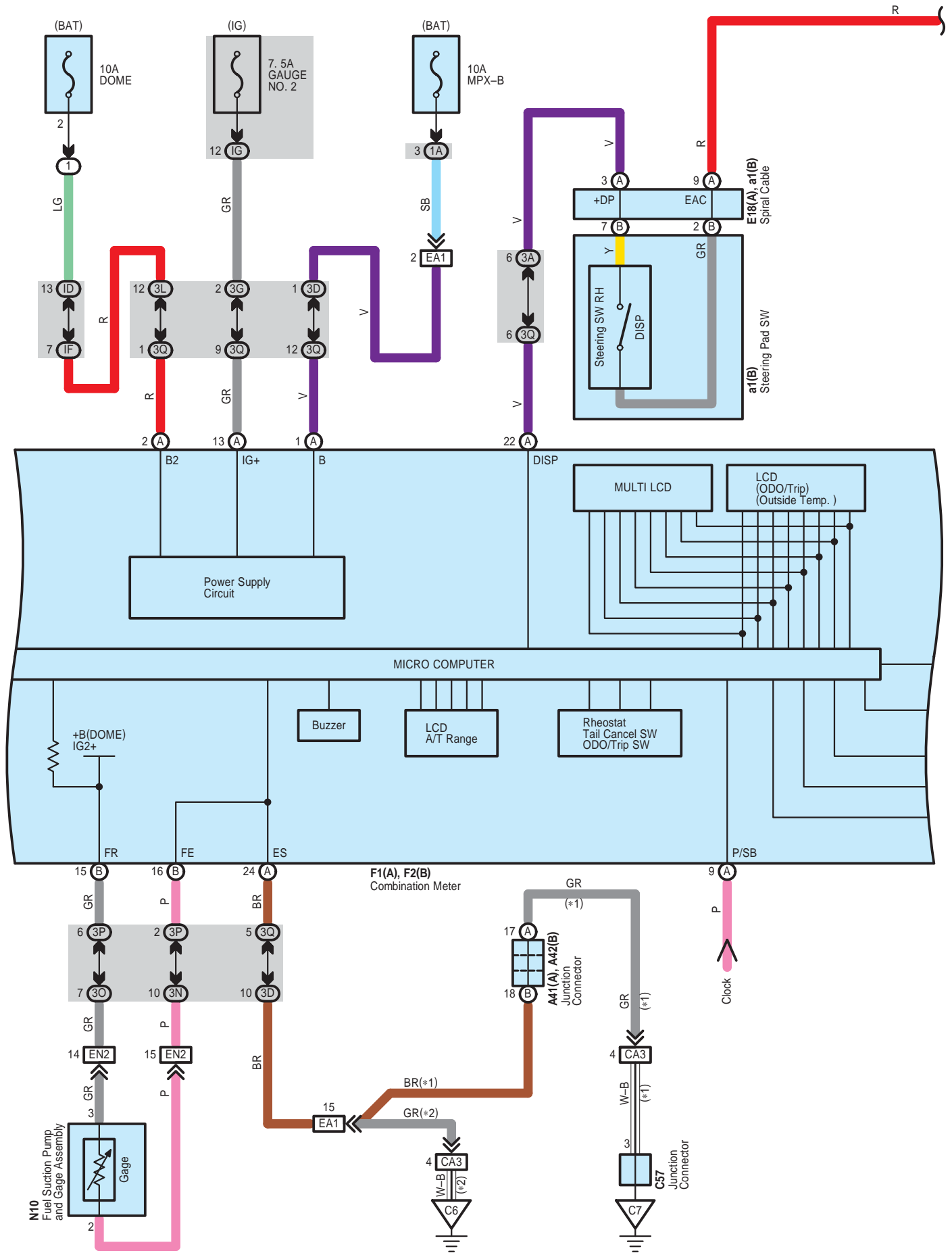



- \* 1 : 2GR-FE
- \* 2 : 2AZ-FE

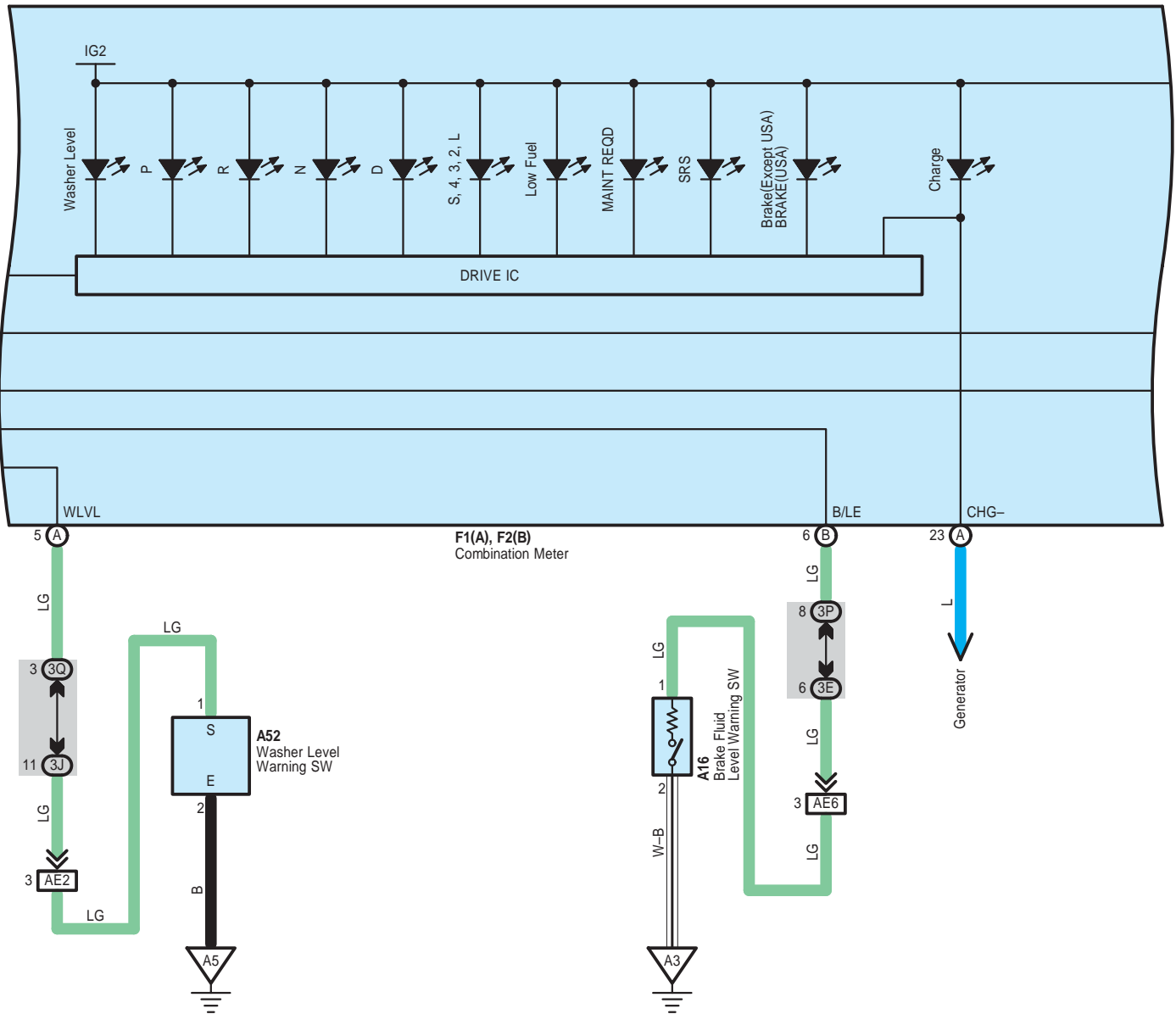

# Combination Meter

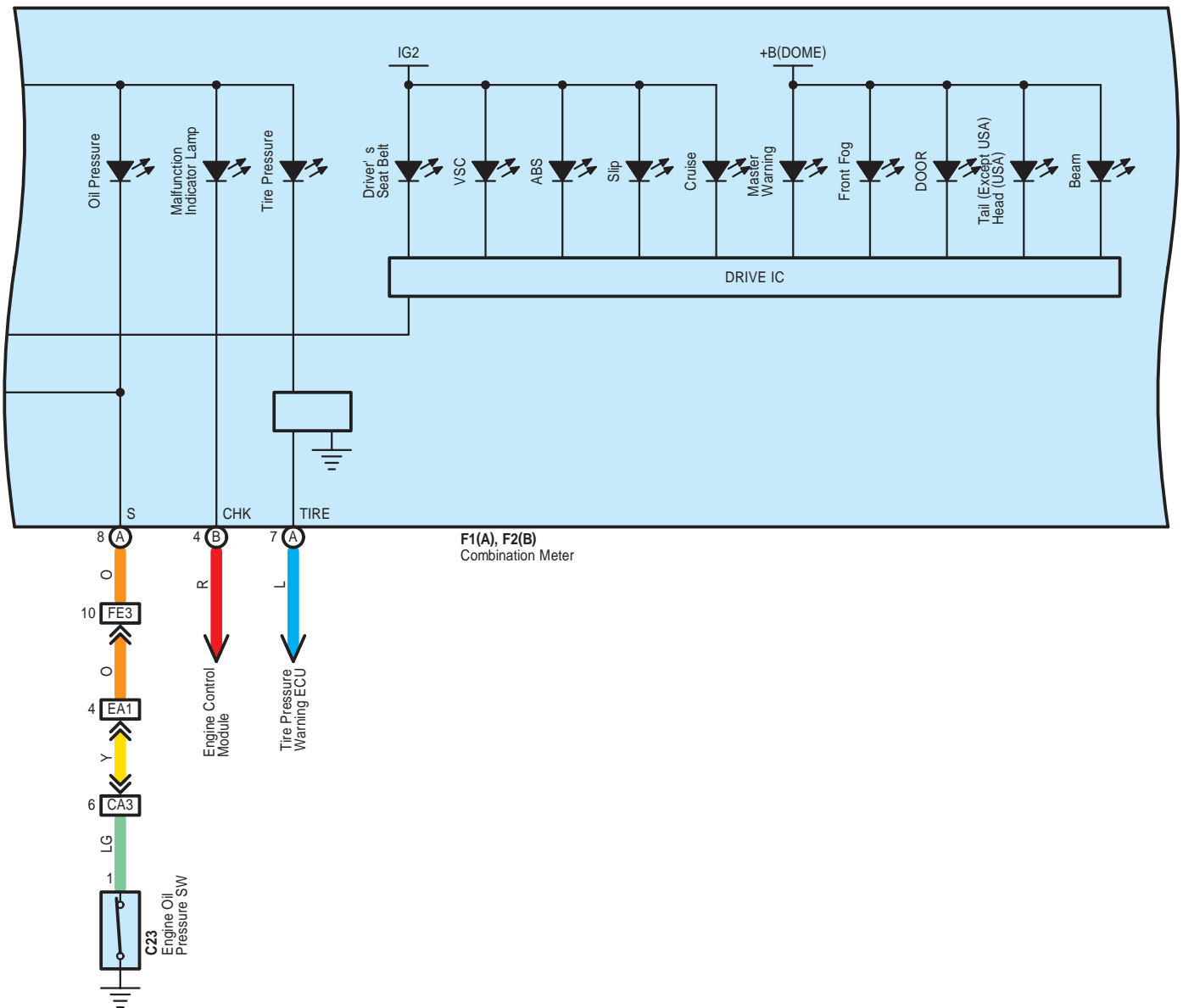

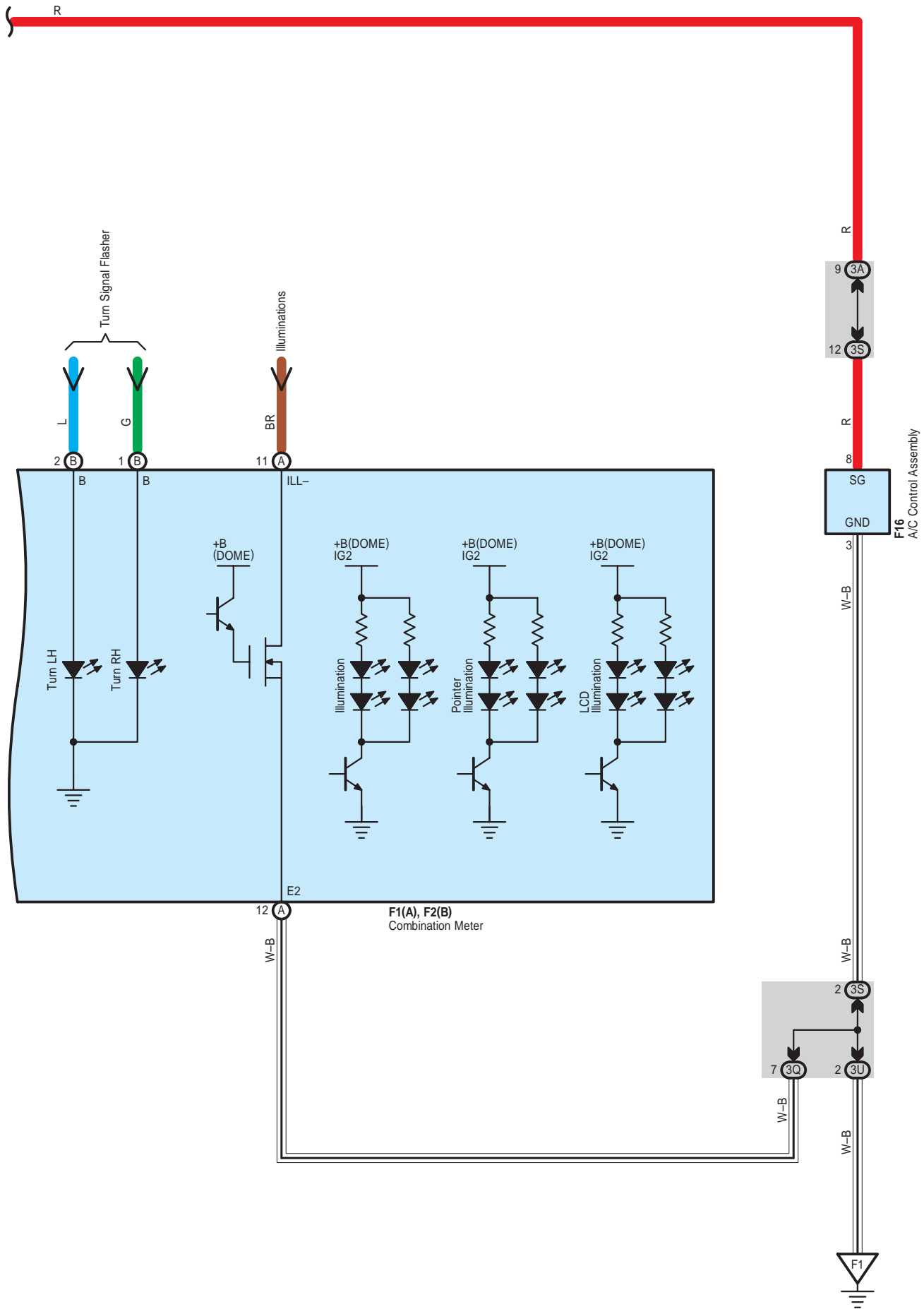

CAMRY (EM0250U)

# Combination Meter

## ○ : Parts Location

| Code | See Page      | Code            | See Page      | Code   | See Page |
|------|---------------|-----------------|---------------|--------|----------|
| A5   | 48 (2GR-FE)   | C4              | 54 (2AZ-FE)   | E58    | A 57     |
|      | 52 (2AZ-FE)   |                 |               | C7     | E59      |
| A16  | 48 (2GR-FE)   | C20             | 55 (2AZ-FE)   |        | E60 57   |
|      | 52 (2AZ-FE)   |                 |               | F1     | A 58     |
| A18  | 59            | C23             | 50 (2GR-FE)   | F2     | B 58     |
| A24  | A 52 (2AZ-FE) |                 | 55 (2AZ-FE)   | F8     | C 58     |
| A25  | 48 (2GR-FE)   | C24             | B 55 (2AZ-FE) | F13    | H 58     |
|      | 52 (2AZ-FE)   | C50 51 (2GR-FE) |               | F16 58 |          |
| A26  | 48 (2GR-FE)   | C55             | B 51 (2GR-FE) | F19    | B 58     |
|      | 52 (2AZ-FE)   | C56 51 (2GR-FE) |               | N6     | A 60     |
| A40  | A 59          | C57 51 (2GR-FE) |               |        | B 60     |
| A41  | A 59          | E6              | A 56          | N10 60 |          |
| A42  | B 59          | E7              | B 56          | N13    | A 60     |
| A43  | 49 (2GR-FE)   | E8              | C 56          |        | B 60     |
| A52  | 49 (2GR-FE)   | E18             | A 56          | N28 60 |          |
|      | 53 (2AZ-FE)   | E33 56          |               | O6 60  |          |
| A55  | A 49 (2GR-FE) | E41             | B 57          | O10 60 |          |
| A60  | 49 (2GR-FE)   | E42             | A 57          | S5 61  |          |
|      | 53 (2AZ-FE)   | E43             | B 57          | S15 61 |          |
| C4   | 50 (2GR-FE)   | E44             | C 57          | a1     | B 59     |

## ○ : Relay Blocks

| Code | See Page | Relay Blocks (Relay Block Location)       |
|------|----------|---|
| 1    | 22       | Engine Room R/B (Engine Compartment Left) |

## ○ : Junction Block and Wire Harness Connector

| Code | See Page | Junction Block and Wire Harness (Connector Location)                   |
|------|----------|--|
| 1A   | 25       | Engine Room Main Wire and Engine Room J/B (Engine Compartment Left)    |
| 3A   | 36       | Instrument Panel Wire and J/B No.3 (Behind the Combination Meter)      |
| 3B   |          |  |
| 3C   |          |  |
| 3D   |          |  |
| 3E   |          |  |
| 3F   |          |  |
| 3G   |          |  |
| 3J   |          |  |
| 3L   |          |  |
| 3M   |          |  |
| 3N   |          |  |
| 3O   | 36       | Instrument Panel No.2 Wire and J/B No.3 (Behind the Combination Meter) |
| 3P   |          |  |
| 3Q   |          |  |
| 3S   |          |  |
| 3T   |          |  |
| 3U   | 30       | Engine Room Main Wire and Instrument Panel J/B (Cowl Side Left)        |
| IC   |          |  |
| ID   |          |  |
| IF   | 30       | Instrument Panel Wire and Instrument Panel J/B (Cowl Side Left)        |
| IG   | 31       |  |
| IH   |          |  |
| IM   | 30       |  |
| IO   | 30       |  |

 : Connector Joining Wire Harness and Wire Harness

| Code | See Page    | Joining Wire Harness and Wire Harness (Connector Location)                                |
|------|-------------|---|
| AE2  | 66          | Engine Room Main Wire and Instrument Panel Wire (Right Side of the Instrument Panel J/B)  |
| AE5  | 66          | Engine Room Main Wire and Instrument Panel Wire (Instrument Panel Right)                  |
| AE6  |             |   |
| CA1  | 64 (2GR-FE) | Engine Wire and Engine Room Main Wire (Inside of the Engine Room R/B and Engine Room J/B) |
|      | 65 (2AZ-FE) |   |
| CA2  | 64 (2GR-FE) |   |
| CA3  | 64 (2GR-FE) |   |
|      | 65 (2AZ-FE) |   |
| EA1  | 66          |   |
| EN2  | 66          | Instrument Panel Wire and Floor Wire (Left Kick Panel)                                    |
| EO2  | 66          | Instrument Panel Wire and Floor No.2 Wire (Right Kick Panel)                              |
| FE3  | 66          | Instrument Panel No.2 Wire and Instrument Panel Wire (Instrument Panel Center)            |
| SN1  | 67          | Luggage Room Wire and Floor Wire (Luggage Room Left)                                      |

 : Ground Points

| Code | See Page    | Ground Points Location           |
|------|-------------|----------------------------------|
| A2   | 64 (2GR-FE) | Front Left Fender                |
|      | 65 (2AZ-FE) |                                  |
| A3   | 66          | Left Cowl Side Panel             |
| A5   | 64 (2GR-FE) | Front Right Fender               |
|      | 65 (2AZ-FE) |                                  |
| C4   | 65 (2AZ-FE) | Cylinder Block                   |
| C5   | 64 (2GR-FE) | Right Side of the Cylinder Block |
| C6   | 65 (2AZ-FE) | Cylinder Block                   |
| C7   | 64 (2GR-FE) | Left Side of the Cylinder Block  |
| F1   | 66          | Instrument Panel Left            |
| S1   | 67          | Lower Back Panel Center          |

# Cooling Fan for 2GR-FE

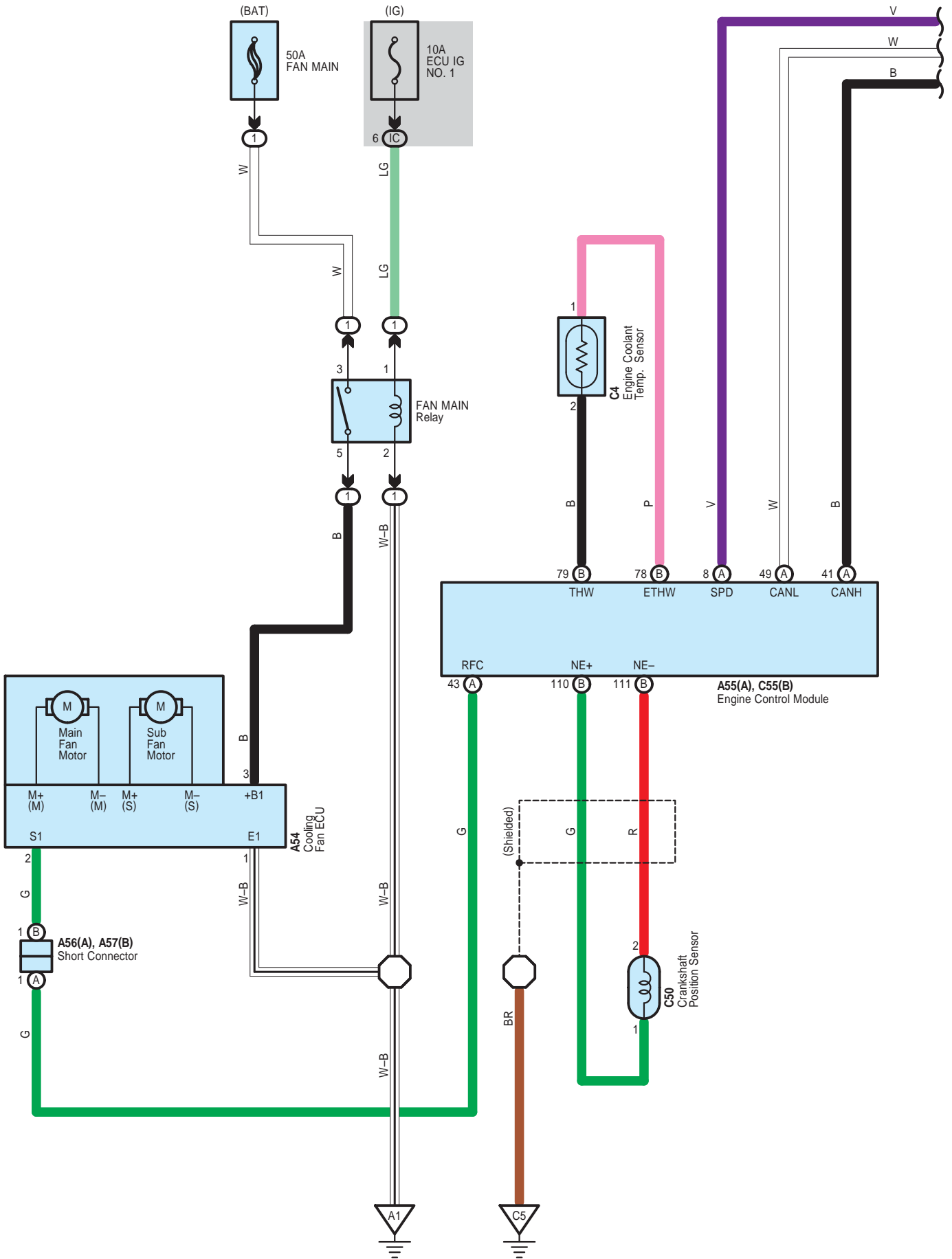

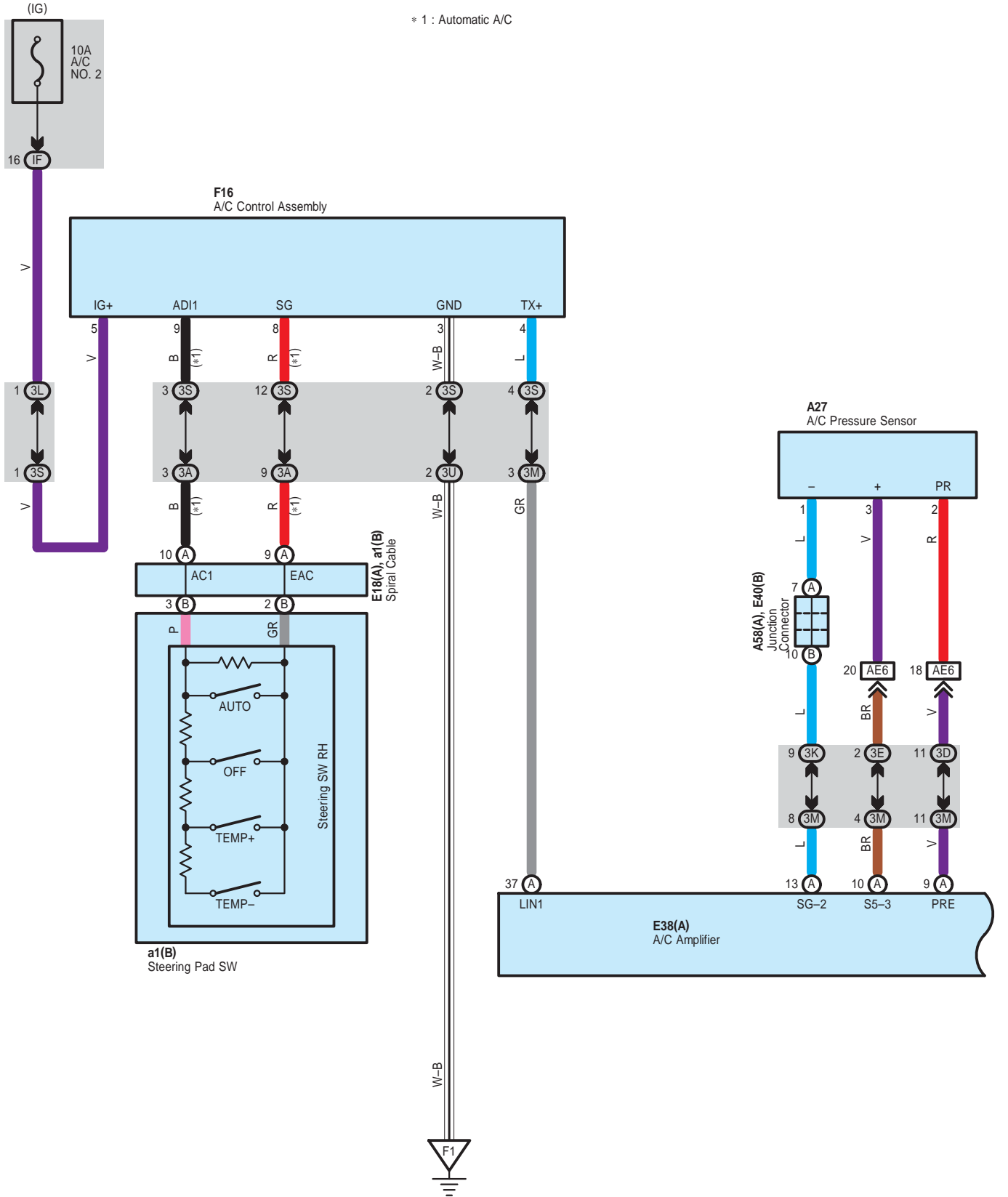
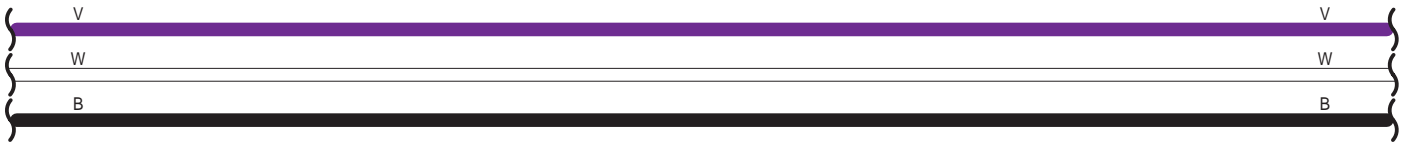



# Cooling Fan for 2GR-FE

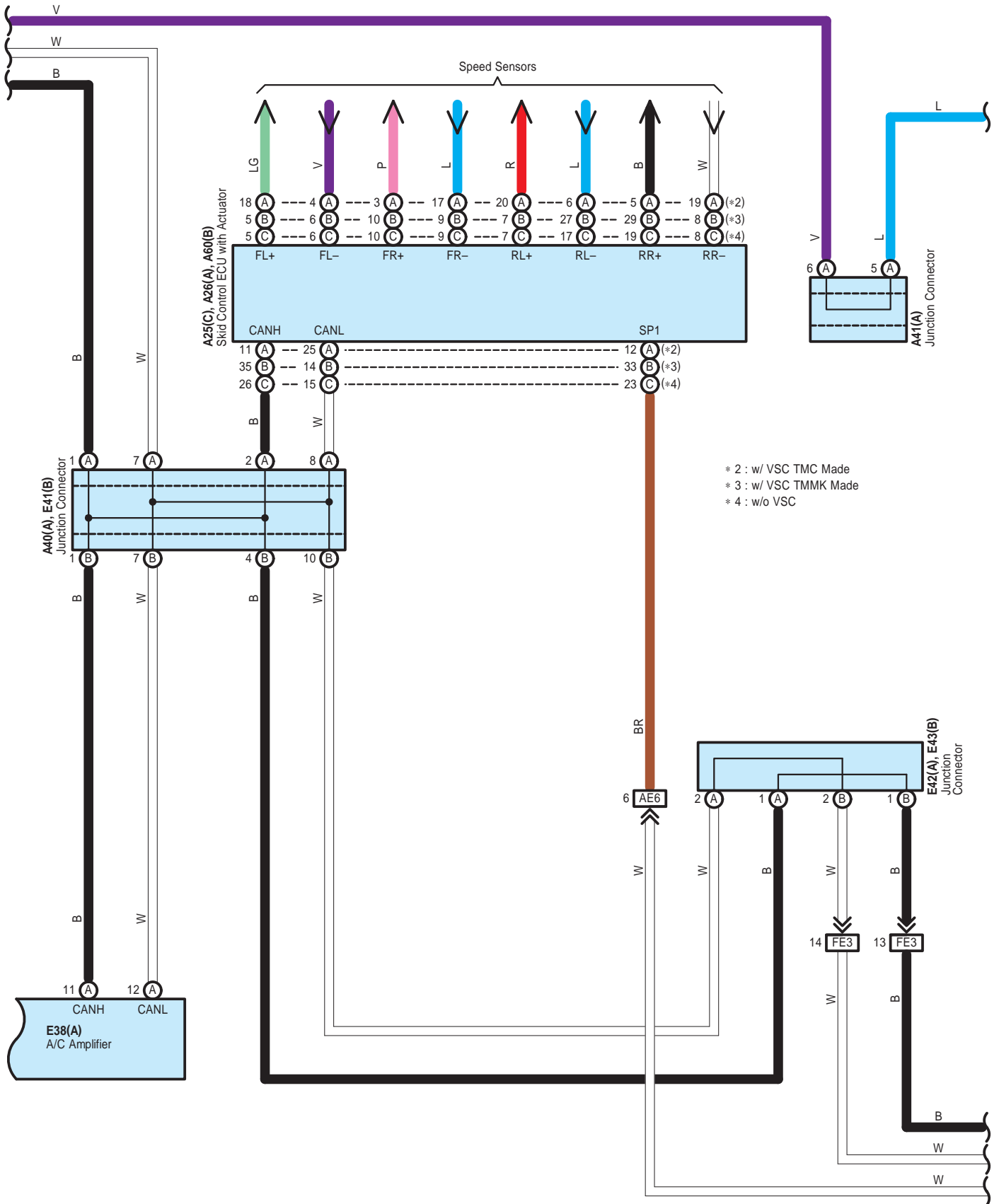

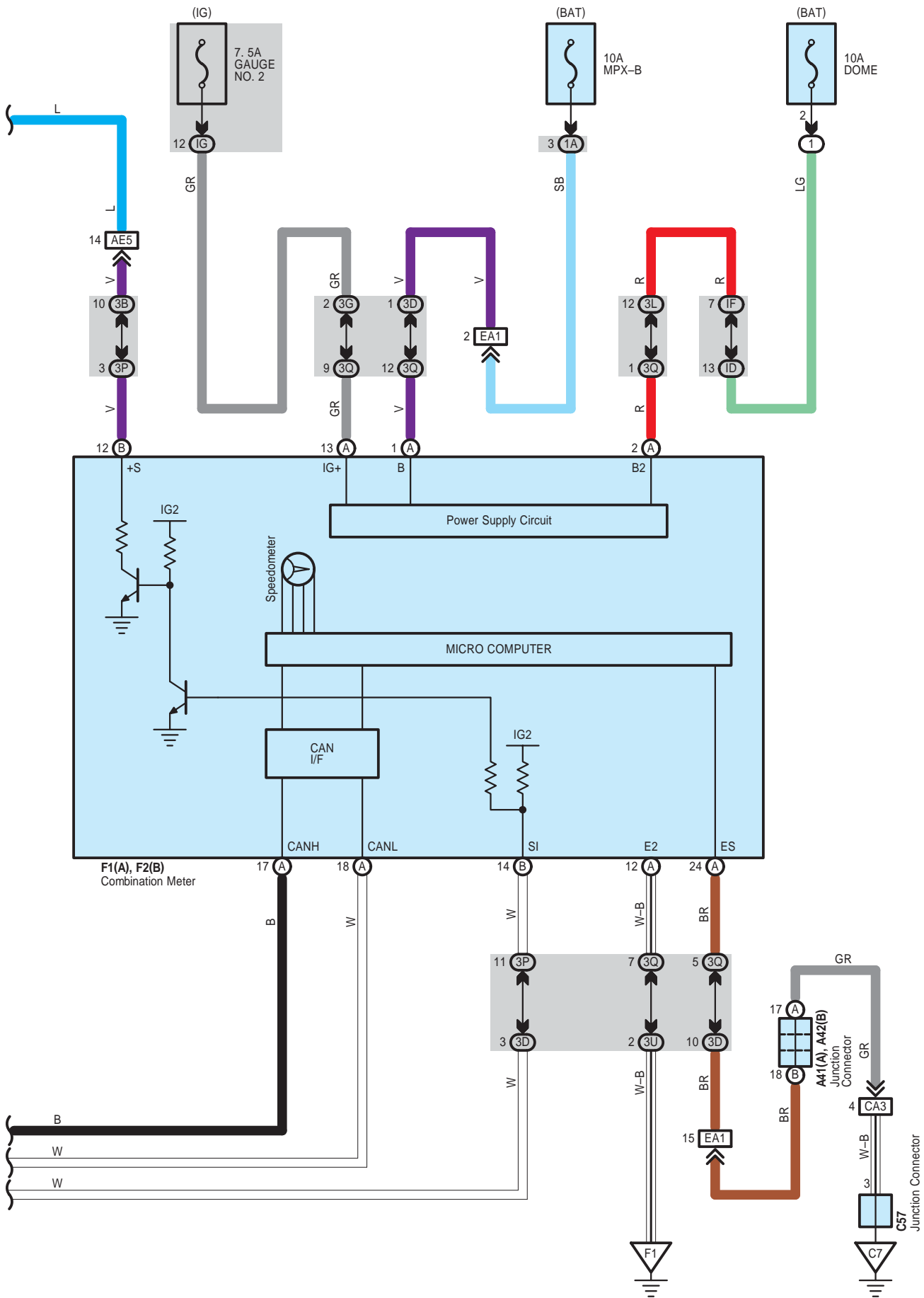

CAMRY (EM0250U)

# Cooling Fan for 2GR-FE

## System Outline

### System Operation

When the power SW is pushed to IG ON position (Power SW type), or when the ignition SW is turned to ON (Ignition SW type), the current from the ECU IG NO.1 fuse is sent to the coil side and the FAN MAIN relay is turned to ON. Then the current flows to TERMINAL 3 of the cooling fan ECU. At the same time, the conditions of the A/C SW, A/C pressure sensor, engine coolant temp. sensor and engine rotation are sent to the TERMINAL 2 as signals from engine control module. As a result of that, the cooling fan ECU continuously controls the rotation of the fan motor and keeps a balance between the cooling efficiency and silentness with the optimal fan rotation.

### ○ : Parts Location

| Code | See Page | Code        | See Page | Code | See Page    |    |
|------|----------|-------------|----------|------|-------------|----|
| A25  | C        | 48 (2GR-FE) | A57      | B    | 59          |    |
| A26  | A        | 48 (2GR-FE) | A58      | A    | 59          |    |
| A27  |          | 48 (2GR-FE) | A60      | B    | 49 (2GR-FE) |    |
| A40  | A        | 59          | C4       |      | 50 (2GR-FE) |    |
| A41  | A        | 59          | C50      |      | 51 (2GR-FE) |    |
| A42  | B        | 59          | C55      | B    | 51 (2GR-FE) |    |
| A54  |          | 49 (2GR-FE) | C57      |      | 51 (2GR-FE) |    |
| A55  | A        | 49 (2GR-FE) | E18      | A    | 56          |    |
| A56  | A        | 59          | E38      | A    | 57          |    |
|      |          |             |          | E40  | B           | 57 |
|      |          |             |          | E41  | B           | 57 |
|      |          |             |          | E42  | A           | 57 |
|      |          |             |          | E43  | B           | 57 |
|      |          |             |          | F1   | A           | 58 |
|      |          |             |          | F2   | B           | 58 |
|      |          |             |          | F16  |             | 58 |
|      |          |             |          | a1   | B           | 59 |

### ○ : Relay Blocks

| Code | See Page | Relay Blocks (Relay Block Location)       |
|------|----------|---|
| 1    | 22       | Engine Room R/B (Engine Compartment Left) |

### ○ : Junction Block and Wire Harness Connector

| Code | See Page | Junction Block and Wire Harness (Connector Location)                   |
|------|----------|--|
| 1A   | 25       | Engine Room Main Wire and Engine Room J/B (Engine Compartment Left)    |
| 3A   | 36       | Instrument Panel Wire and J/B No.3 (Behind the Combination Meter)      |
| 3B   |          |  |
| 3D   |          |  |
| 3E   |          |  |
| 3G   |          |  |
| 3K   |          |  |
| 3L   |          |  |
| 3M   |          |  |
| 3P   | 36       | Instrument Panel No.2 Wire and J/B No.3 (Behind the Combination Meter) |
| 3Q   |          |  |
| 3S   |          |  |
| 3U   |          |  |
| IC   | 30       | Engine Room Main Wire and Instrument Panel J/B (Cowl Side Left)        |
| ID   |          |  |
| IF   | 30       | Instrument Panel Wire and Instrument Panel J/B (Cowl Side Left)        |
| IG   | 31       |  |

### □ : Connector Joining Wire Harness and Wire Harness

| Code | See Page    | Joining Wire Harness and Wire Harness (Connector Location)                                |
|------|-------------|---|
| AE5  | 66          | Engine Room Main Wire and Instrument Panel Wire (Instrument Panel Right)                  |
| AE6  |             |   |
| CA3  | 64 (2GR-FE) | Engine Wire and Engine Room Main Wire (Inside of the Engine Room R/B and Engine Room J/B) |
| EA1  | 66          | Instrument Panel Wire and Engine Room Main Wire (Left Kick Panel)                         |
| FE3  | 66          | Instrument Panel No.2 Wire and Instrument Panel Wire (Instrument Panel Center)            |



**: Ground Points**

| Code | See Page    | Ground Points Location           |
|------|-------------|----------------------------------|
| A1   | 64 (2GR-FE) | Front Left Fender                |
| C5   | 64 (2GR-FE) | Right Side of the Cylinder Block |
| C7   | 64 (2GR-FE) | Left Side of the Cylinder Block  |
| F1   | 66          | Instrument Panel Left            |

# Radiator Fan and Condenser Fan for 2AZ-FE

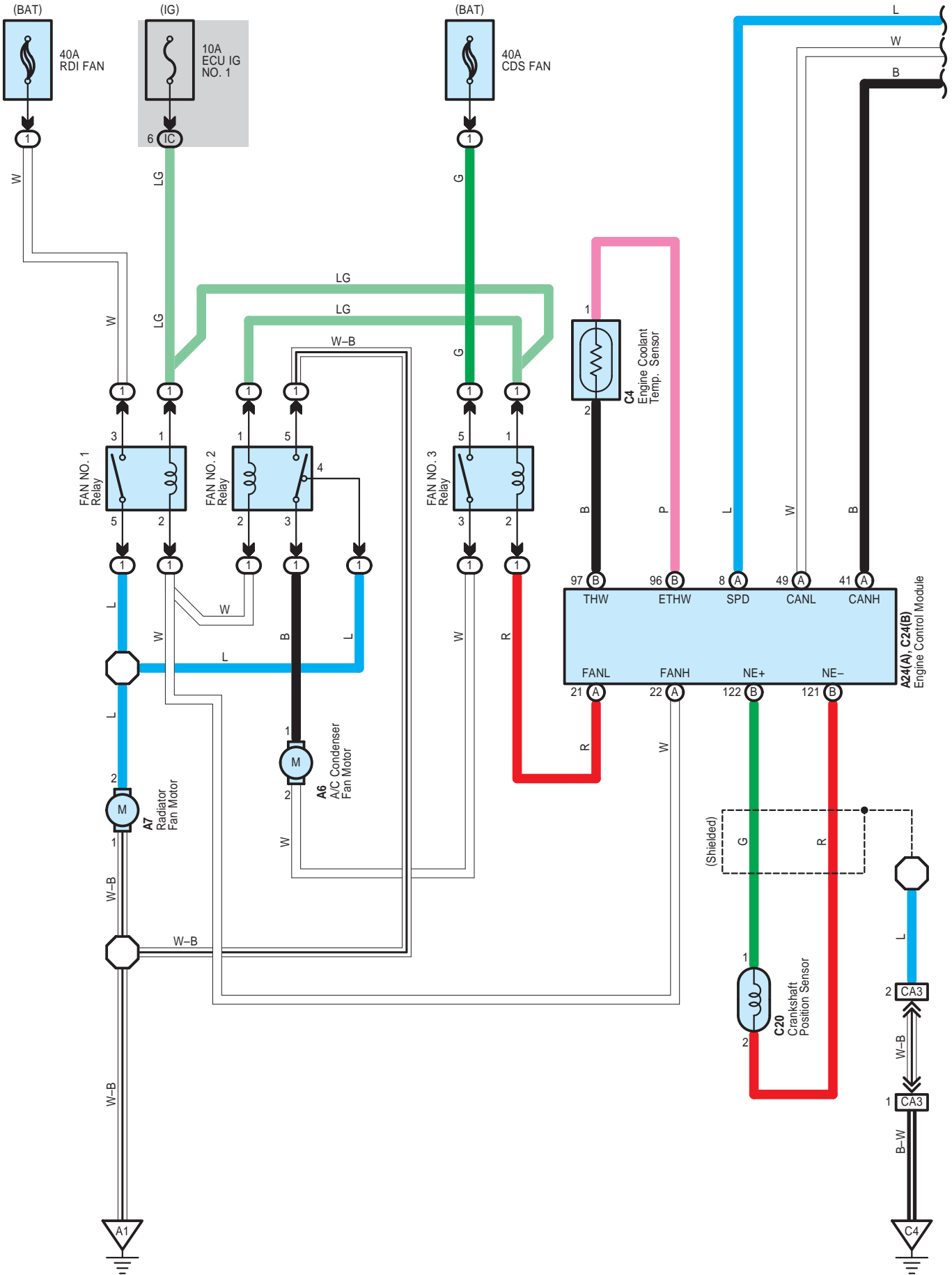

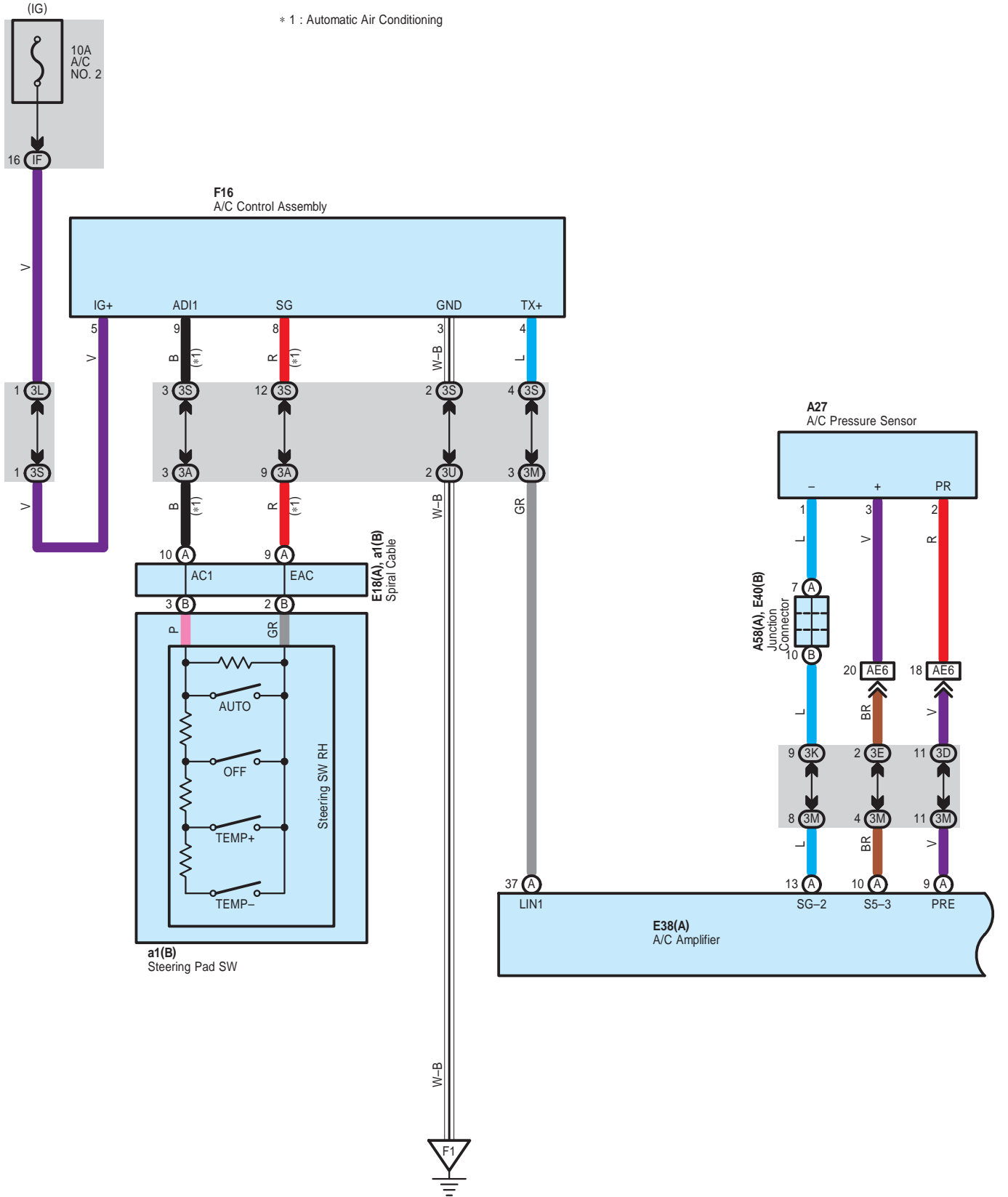

# Radiator Fan and Condenser Fan for 2AZ-FE

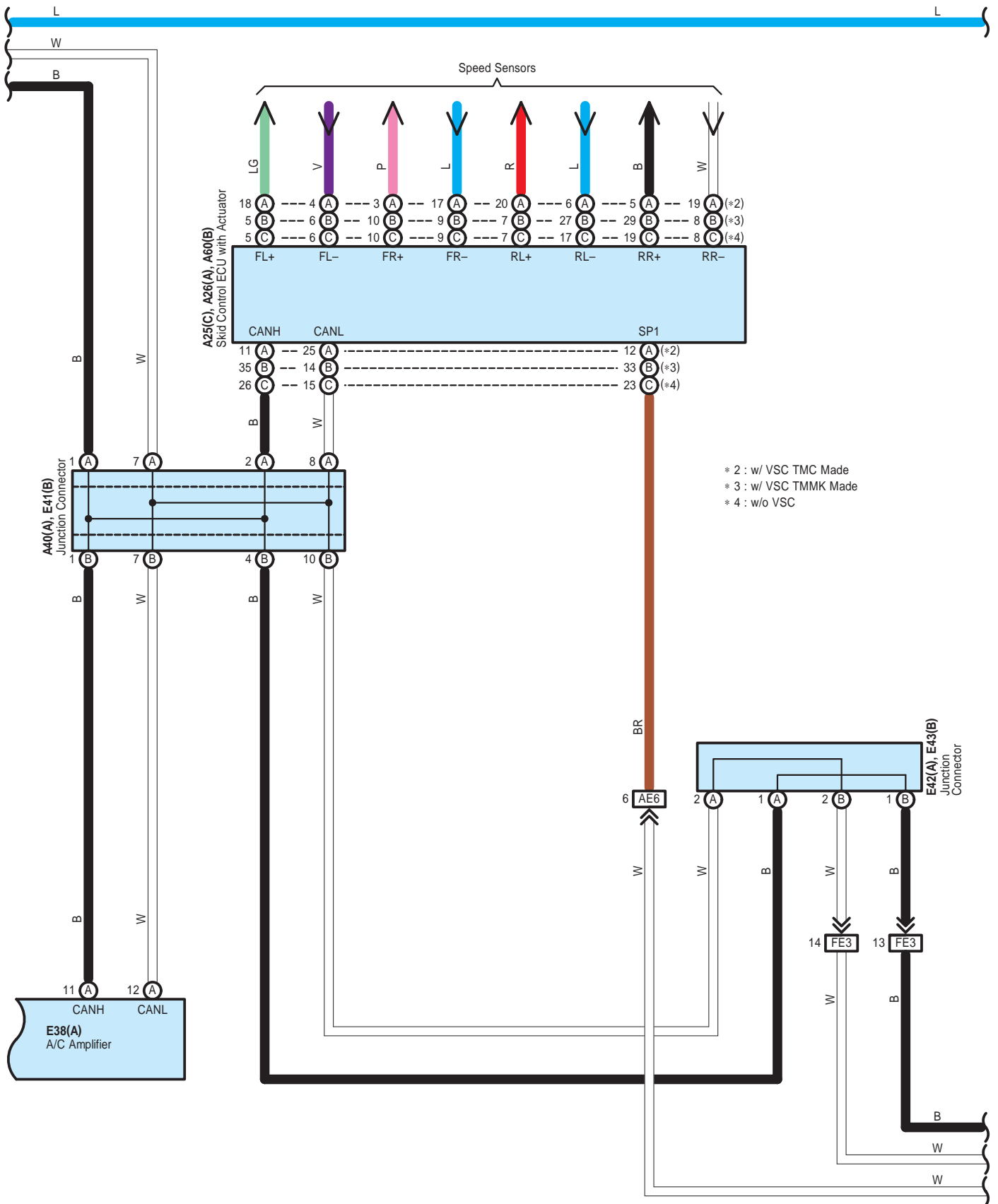

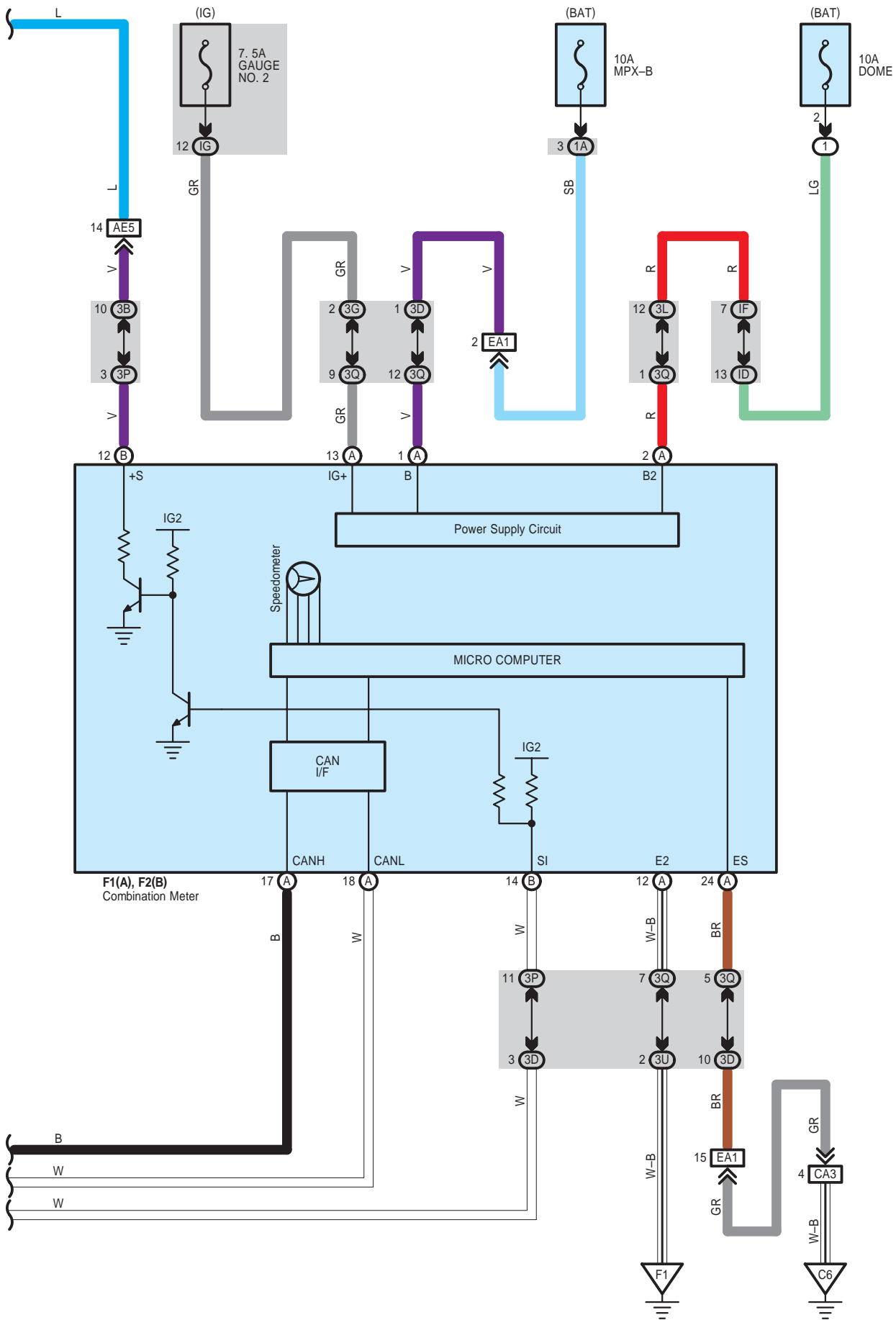

CAMRY (EM0250U)



# Radiator Fan and Condenser Fan for 2AZ-FE

## : Parts Location

| Code | See Page    | Code        | See Page | Code        | See Page    |     |    |    |
|------|-------------|-------------|----------|-------------|-------------|-----|----|----|
| A6   | 52 (2AZ-FE) | A60         | B        | 53 (2AZ-FE) | E42         | A   | 57 |    |
| A7   | 52 (2AZ-FE) | C4          |          | 54 (2AZ-FE) | E43         | B   | 57 |    |
| A24  | A           | 52 (2AZ-FE) | C20      | 55 (2AZ-FE) | F1          | A   | 58 |    |
| A25  | C           | 52 (2AZ-FE) | C24      | B           | 55 (2AZ-FE) | F2  | B  | 58 |
| A26  | A           | 52 (2AZ-FE) | E18      | A           | 56          | F16 |    | 58 |
| A27  |             | 52 (2AZ-FE) | E38      | A           | 57          | a1  | B  | 59 |
| A40  | A           | 59          | E40      | B           | 57          |     |    |    |
| A58  | A           | 59          | E41      | B           | 57          |     |    |    |

## : Relay Blocks

| Code | See Page | Relay Blocks (Relay Block Location)       |
|------|----------|---|
| 1    | 22       | Engine Room R/B (Engine Compartment Left) |

## : Junction Block and Wire Harness Connector

| Code | See Page | Junction Block and Wire Harness (Connector Location)                   |
|------|----------|--|
| 1A   | 25       | Engine Room Main Wire and Engine Room J/B (Engine Compartment Left)    |
| 3A   | 36       | Instrument Panel Wire and J/B No.3 (Behind the Combination Meter)      |
| 3B   |          |  |
| 3D   |          |  |
| 3E   |          |  |
| 3G   |          |  |
| 3K   |          |  |
| 3L   |          |  |
| 3M   |          |  |
| 3P   | 36       | Instrument Panel No.2 Wire and J/B No.3 (Behind the Combination Meter) |
| 3Q   |          |  |
| 3S   |          |  |
| 3U   |          |  |
| IC   | 30       | Engine Room Main Wire and Instrument Panel J/B (Cowl Side Left)        |
| ID   |          |  |
| IF   | 30       | Instrument Panel Wire and Instrument Panel J/B (Cowl Side Left)        |
| IG   | 31       |  |

## : Connector Joining Wire Harness and Wire Harness

| Code | See Page    | Joining Wire Harness and Wire Harness (Connector Location)                                |
|------|-------------|---|
| AE5  | 66          | Engine Room Main Wire and Instrument Panel Wire (Instrument Panel Right)                  |
| AE6  |             |   |
| CA3  | 65 (2AZ-FE) | Engine Wire and Engine Room Main Wire (Inside of the Engine Room R/B and Engine Room J/B) |
| EA1  | 66          | Instrument Panel Wire and Engine Room Main Wire (Left Kick Panel)                         |
| FE3  | 66          | Instrument Panel No.2 Wire and Instrument Panel Wire (Instrument Panel Center)            |

## : Ground Points

| Code | See Page    | Ground Points Location |
|------|-------------|------------------------|
| A1   | 65 (2AZ-FE) | Front Left Fender      |
| C4   | 65 (2AZ-FE) | Cylinder Block         |
| C6   |             |                        |
| F1   | 66          | Instrument Panel Left  |



# Air Conditioning

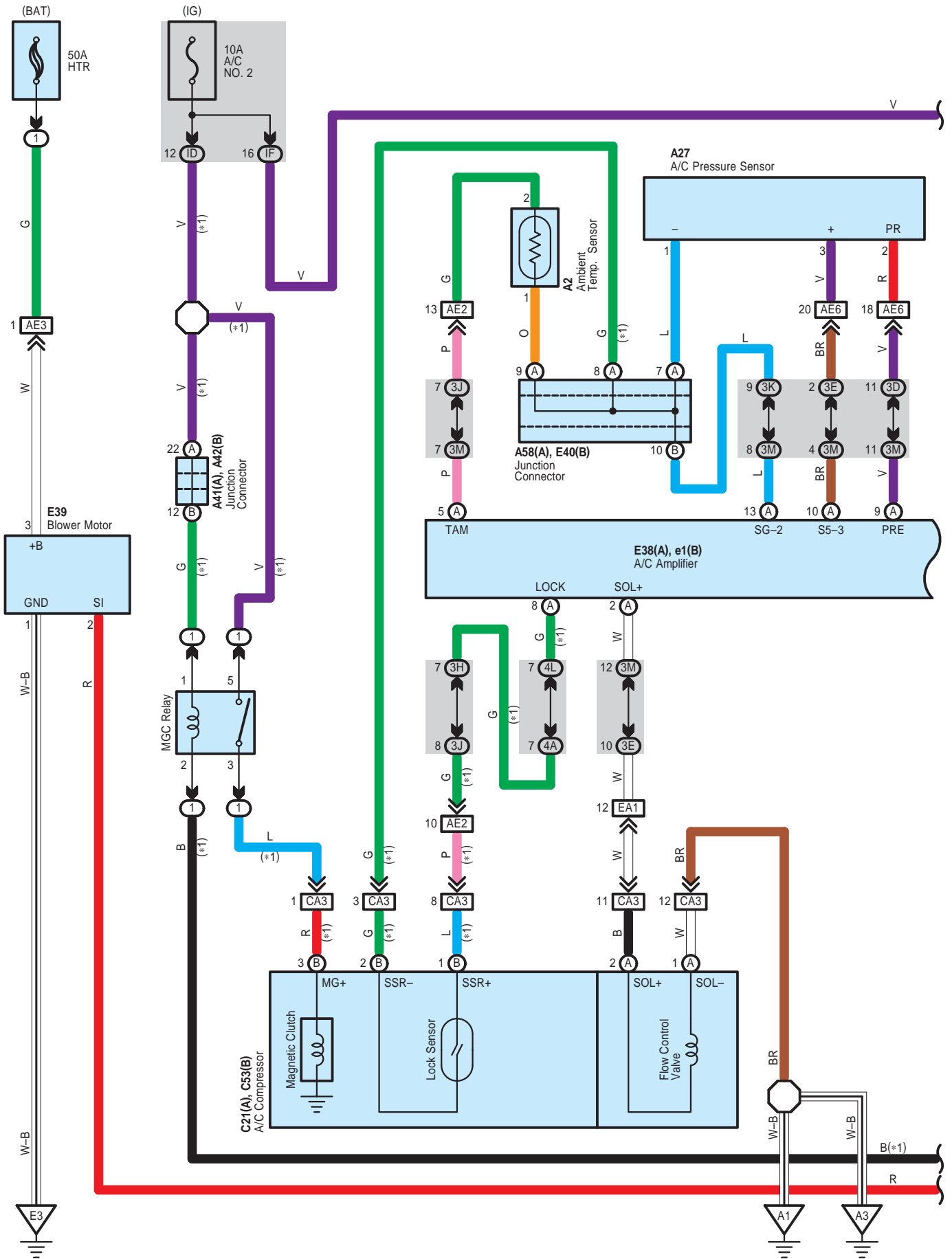

\* 1 : 2GR-FE  
 \* 2 : Automatic A/C

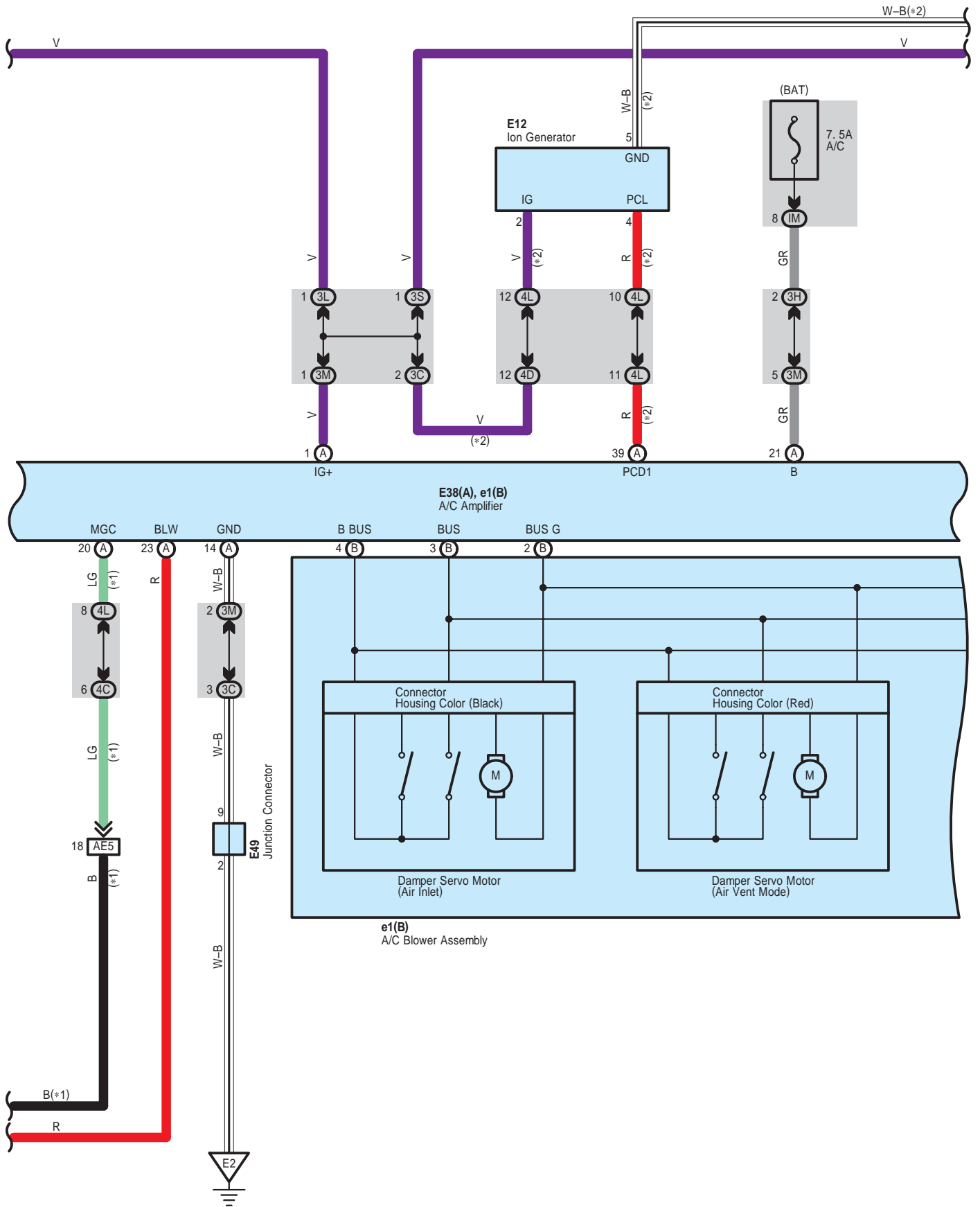

# Air Conditioning

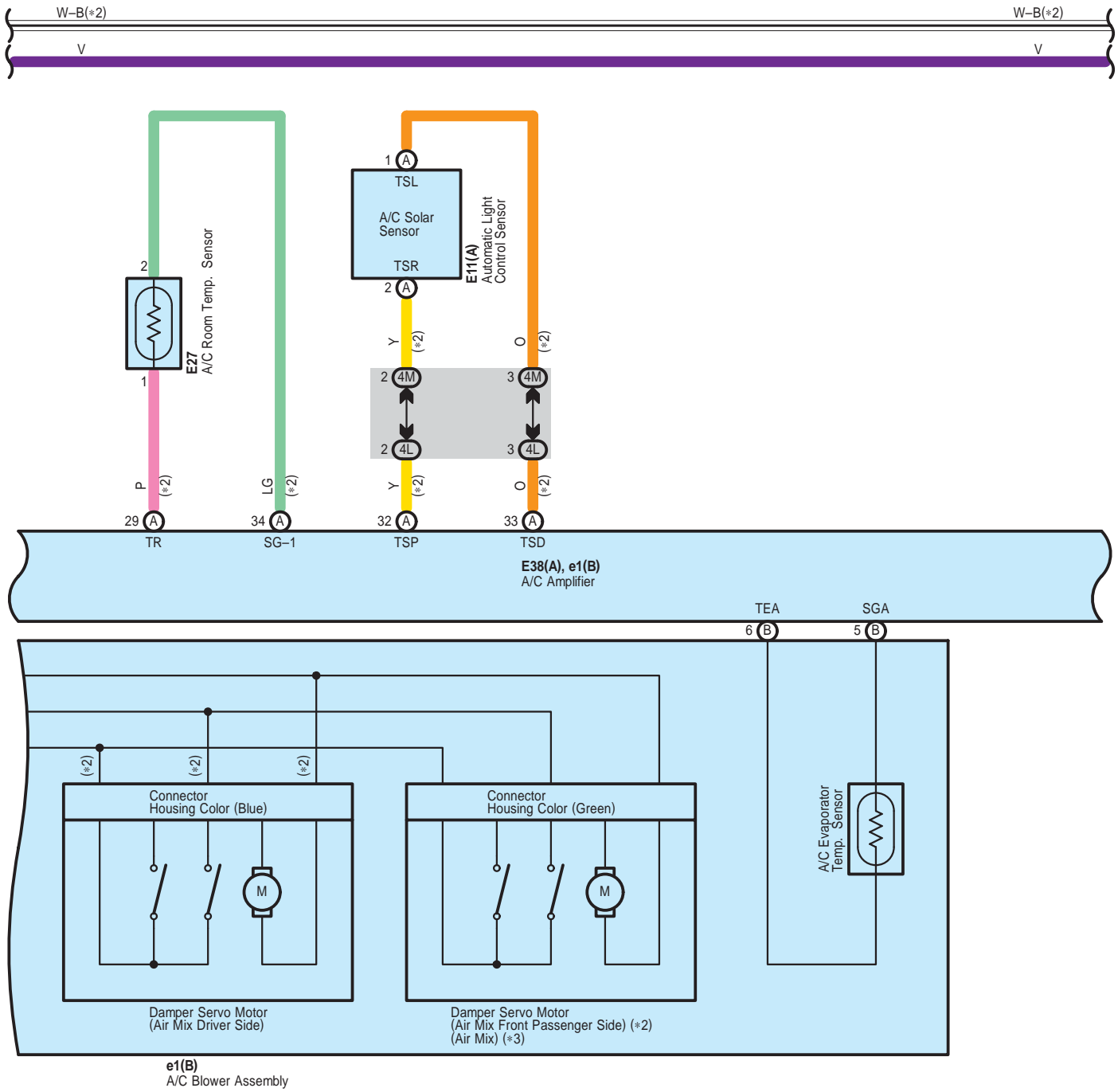

\* 2 : Automatic A/C  
 \* 3 : Manual A/C

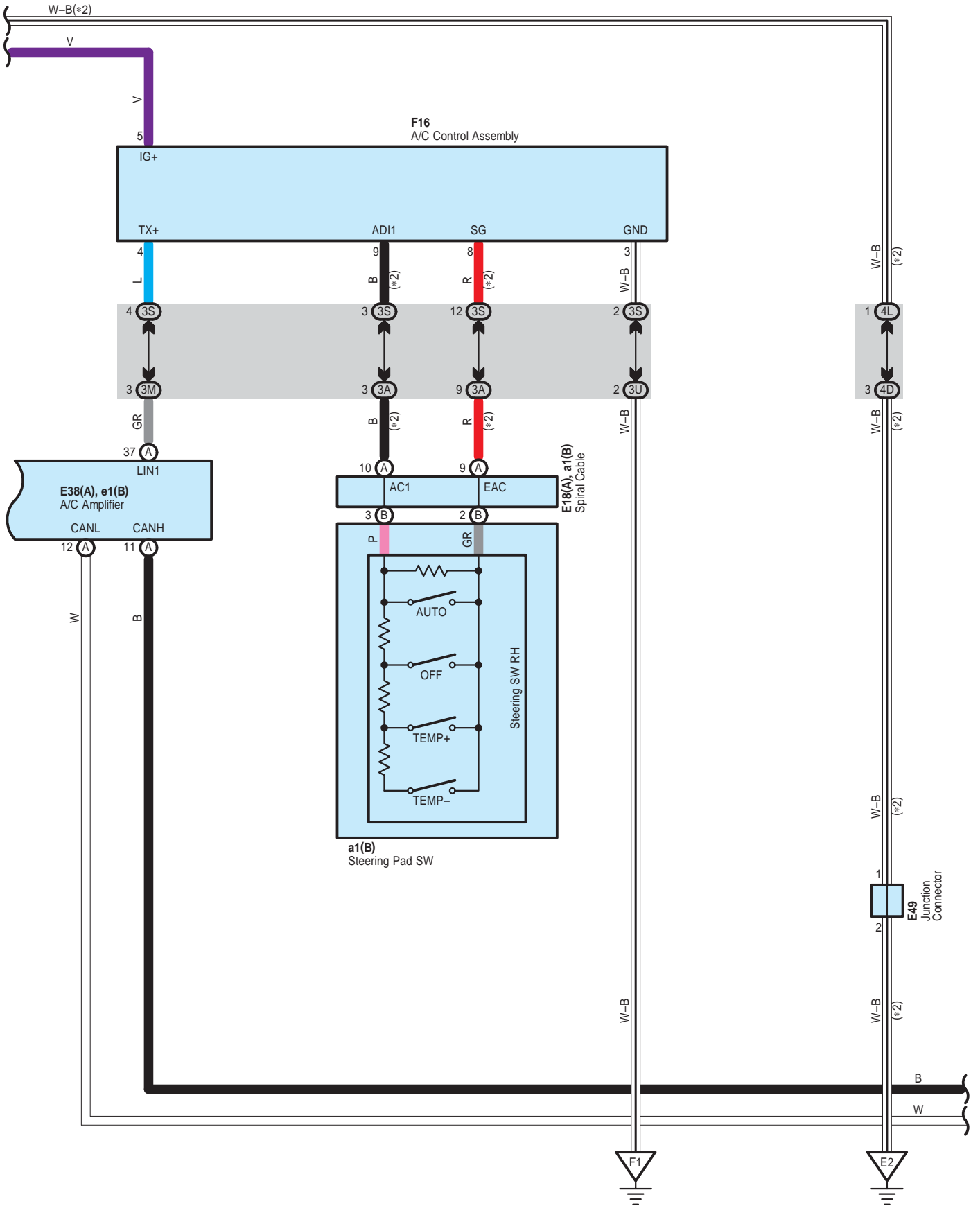

# Air Conditioning

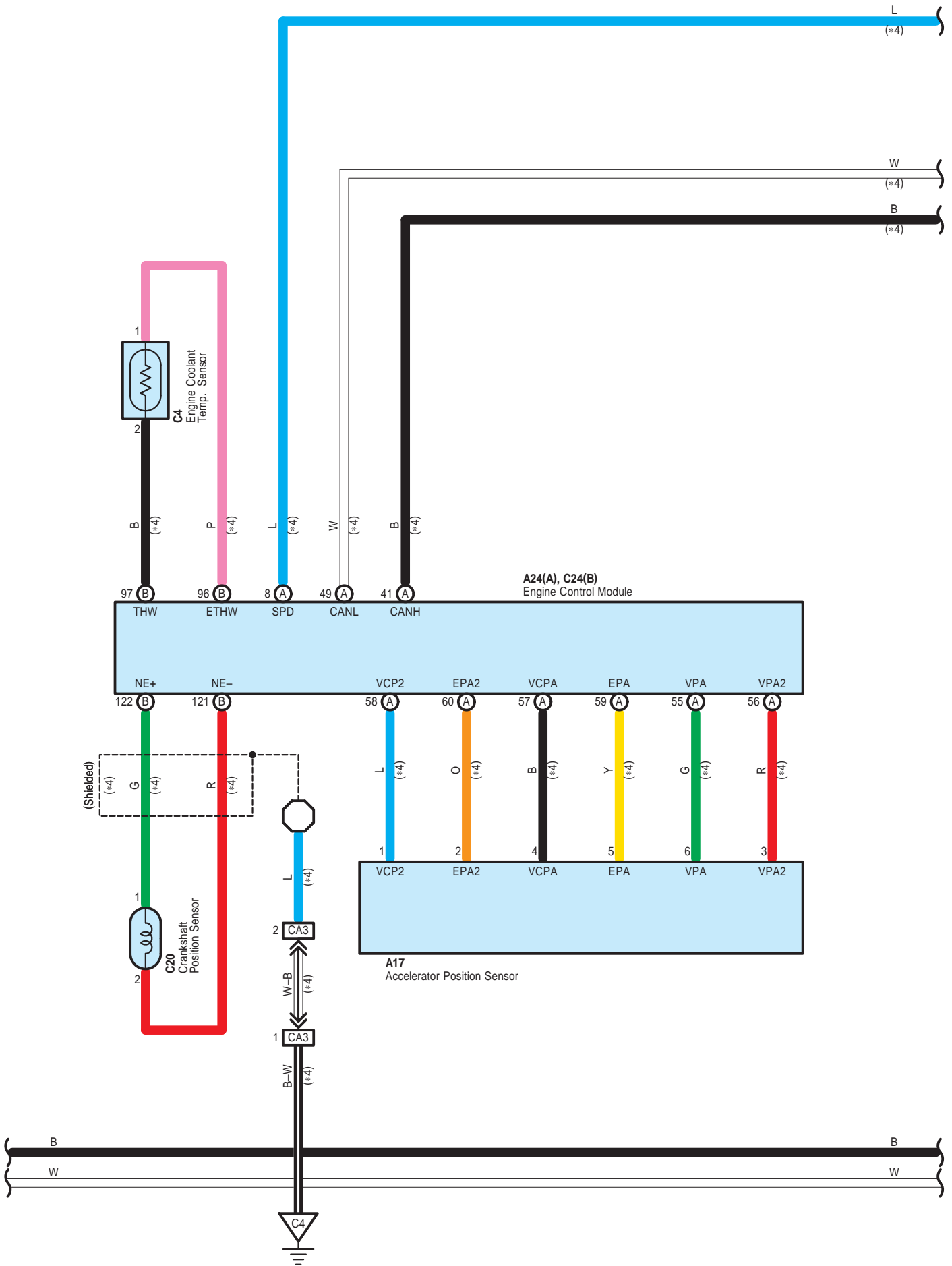

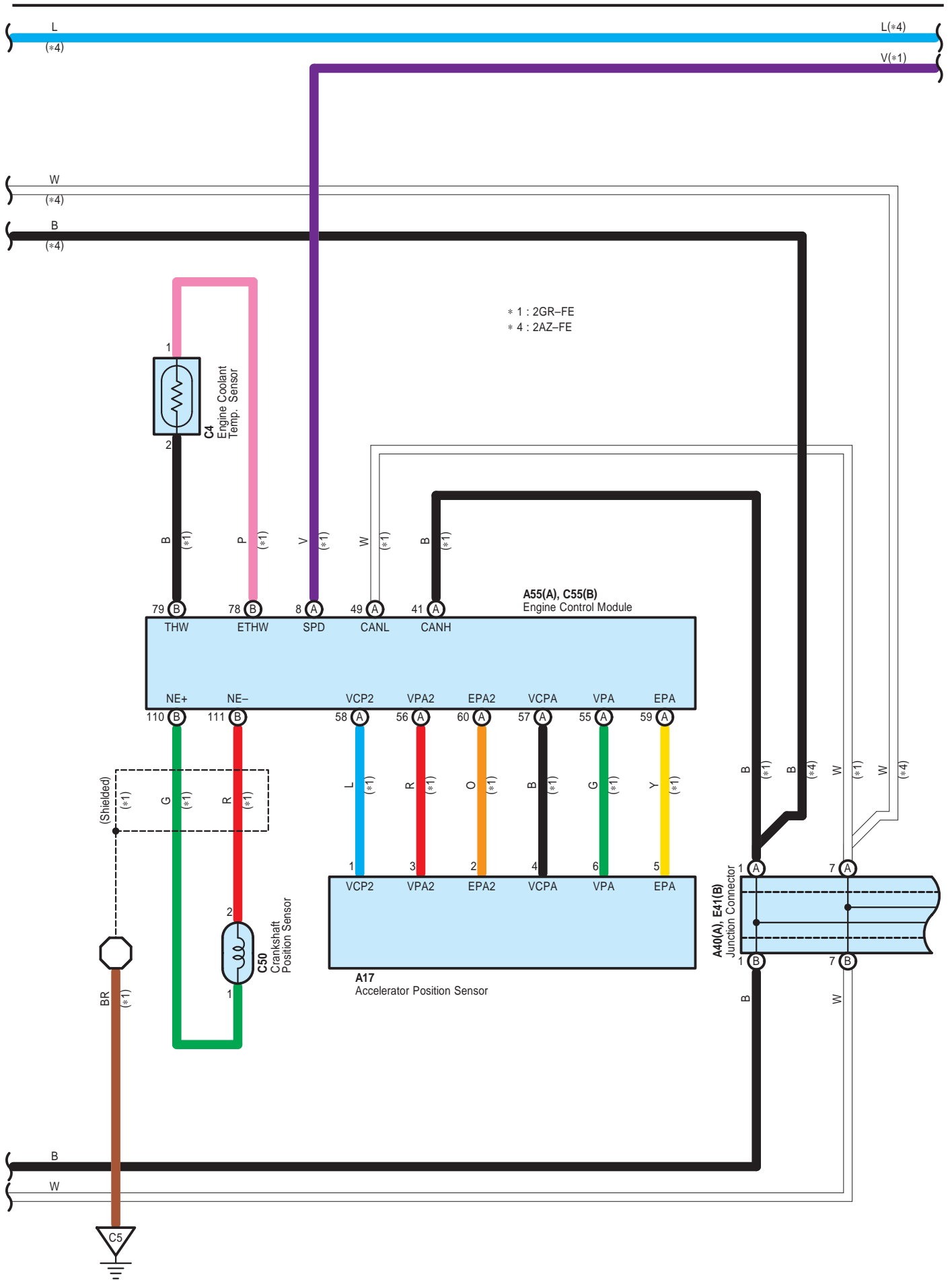



# Air Conditioning

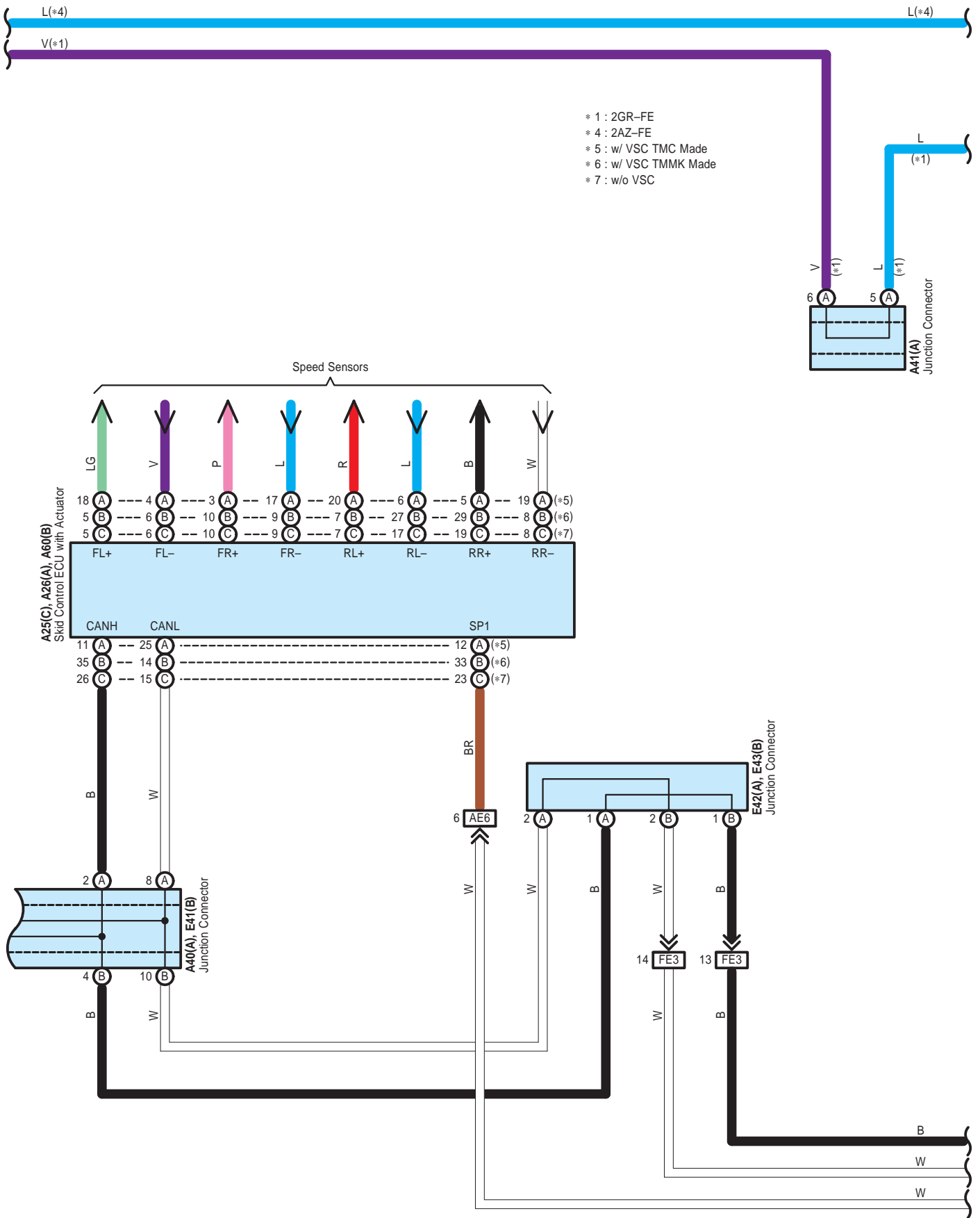

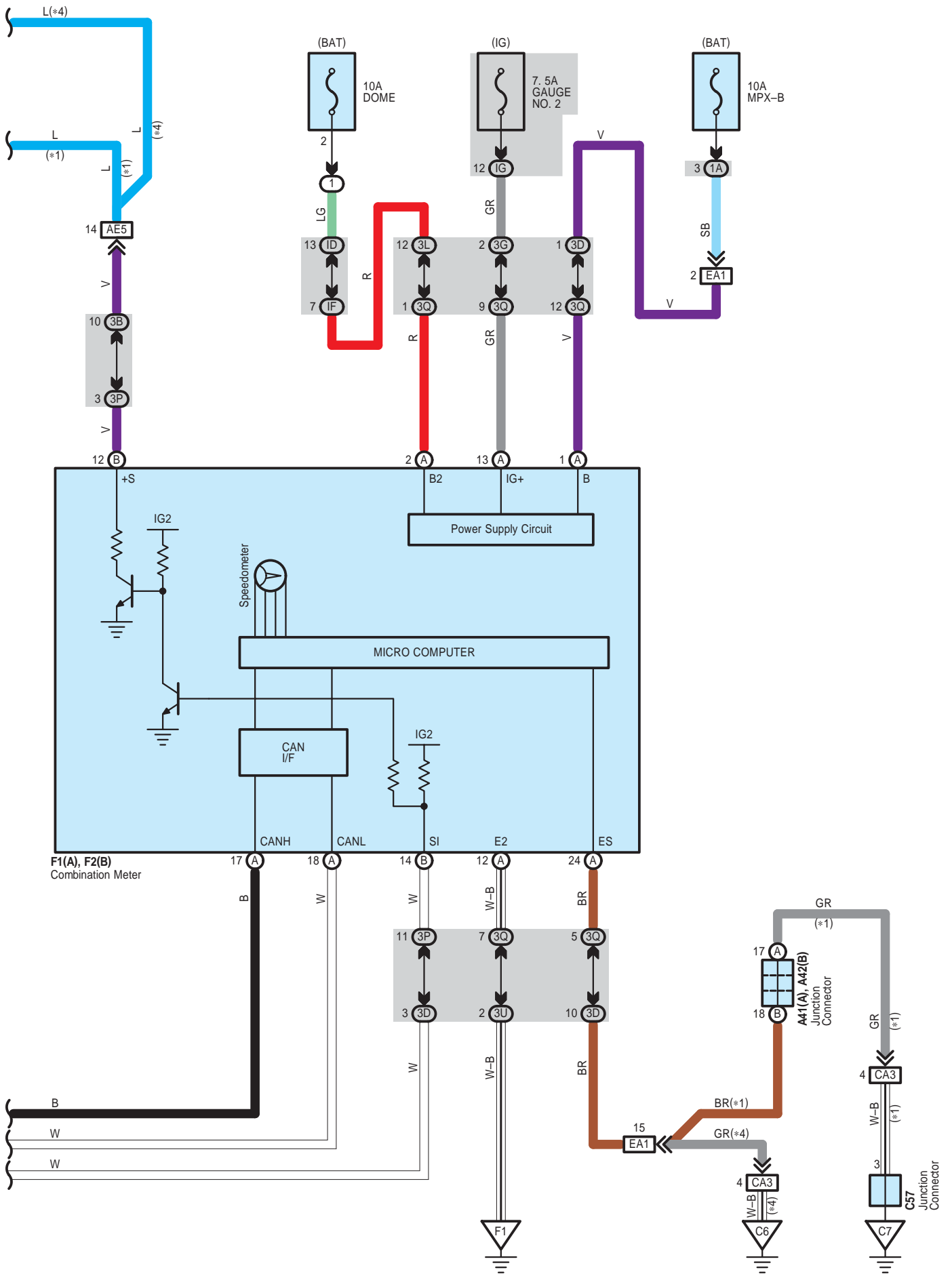

CAMRY (EM0250U)

# Air Conditioning

## ○ : Parts Location

| Code | See Page    | Code        | See Page | Code        | See Page    |     |    |    |
|------|-------------|-------------|----------|-------------|-------------|-----|----|----|
| A2   | 48 (2GR-FE) | A60         | B        | 49 (2GR-FE) | E27         | 56  |    |    |
|      | 52 (2AZ-FE) |             |          | 53 (2AZ-FE) | E38         | A   | 57 |    |
| A17  | 59          | C4          |          | 50 (2GR-FE) | E39         | 57  |    |    |
| A24  | A           |             |          | 52 (2AZ-FE) | E40         | B   | 57 |    |
| A25  | 48 (2GR-FE) | C20         |          | 55 (2AZ-FE) | E41         | B   | 57 |    |
|      | 52 (2AZ-FE) | C21         | A        | 50 (2GR-FE) | E42         | A   | 57 |    |
| A26  | 48 (2GR-FE) |             |          | 55 (2AZ-FE) | E43         | B   | 57 |    |
|      |             | 52 (2AZ-FE) | C24      | B           | 55 (2AZ-FE) | E49 | 57 |    |
| A27  | 48 (2GR-FE) | C50         |          | 51 (2GR-FE) | F1          | A   | 58 |    |
|      | 52 (2AZ-FE) | C53         | B        | 51 (2GR-FE) | F2          | B   | 58 |    |
| A40  | A           | 59          | C55      | B           | 51 (2GR-FE) | F16 | 58 |    |
| A41  | A           | 59          | C57      |             | 51 (2GR-FE) | a1  | B  | 59 |
| A42  | B           | 59          | E11      | A           | 56          | e1  | B  | 59 |
| A55  | A           | 49 (2GR-FE) | E12      |             | 56          |     |    |    |
| A58  | A           | 59          | E18      | A           | 56          |     |    |    |

## ○ : Relay Blocks

| Code | See Page | Relay Blocks (Relay Block Location)       |
|------|----------|---|
| 1    | 22       | Engine Room R/B (Engine Compartment Left) |

## ○ : Junction Block and Wire Harness Connector

| Code | See Page | Junction Block and Wire Harness (Connector Location)                   |
|------|----------|--|
| 1A   | 25       | Engine Room Main Wire and Engine Room J/B (Engine Compartment Left)    |
| 3A   | 36       | Instrument Panel Wire and J/B No.3 (Behind the Combination Meter)      |
| 3B   |          |  |
| 3C   |          |  |
| 3D   |          |  |
| 3E   |          |  |
| 3G   |          |  |
| 3H   |          |  |
| 3J   |          |  |
| 3K   |          |  |
| 3L   |          |  |
| 3M   |          |  |
| 3P   | 36       | Instrument Panel No.2 Wire and J/B No.3 (Behind the Combination Meter) |
| 3Q   |          |  |
| 3S   |          |  |
| 3U   |          |  |
| 4A   | 42       | Instrument Panel Wire and J/B No.4 (Instrument Panel Brace Center)     |
| 4C   |          |  |
| 4D   |          |  |
| 4L   |          |  |
| 4M   |          |  |
| ID   | 30       | Engine Room Main Wire and Instrument Panel J/B (Cowl Side Left)        |
| IF   | 30       | Instrument Panel Wire and Instrument Panel J/B (Cowl Side Left)        |
| IG   | 31       |  |
| IM   | 30       |  |

 : Connector Joining Wire Harness and Wire Harness

| Code | See Page                   | Joining Wire Harness and Wire Harness (Connector Location)                                |
|------|----------------------------|---|
| AE2  | 66                         | Engine Room Main Wire and Instrument Panel Wire (Right Side of the Instrument Panel J/B)  |
| AE3  | 66                         | Engine Room Main Wire and Instrument Panel Wire (Instrument Panel Right)                  |
| AE5  |                            |   |
| AE6  |                            |   |
| CA3  | 64 (2GR-FE)<br>65 (2AZ-FE) | Engine Wire and Engine Room Main Wire (Inside of the Engine Room R/B and Engine Room J/B) |
| EA1  | 66                         | Instrument Panel Wire and Engine Room Main Wire (Left Kick Panel)                         |
| FE3  | 66                         | Instrument Panel No.2 Wire and Instrument Panel Wire (Instrument Panel Center)            |

 : Ground Points

| Code | See Page    | Ground Points Location           |
|------|-------------|----------------------------------|
| A1   | 64 (2GR-FE) | Front Left Fender                |
|      | 65 (2AZ-FE) |                                  |
| A3   | 66          | Left Cowl Side Panel             |
| C4   | 65 (2AZ-FE) | Cylinder Block                   |
| C5   | 64 (2GR-FE) | Right Side of the Cylinder Block |
| C6   | 65 (2AZ-FE) | Cylinder Block                   |
| C7   | 64 (2GR-FE) | Left Side of the Cylinder Block  |
| E2   | 66          | Instrument Panel Brace LH        |
| E3   | 66          | Instrument Panel Right           |
| F1   | 66          | Instrument Panel Left            |

# I GROUND POINT

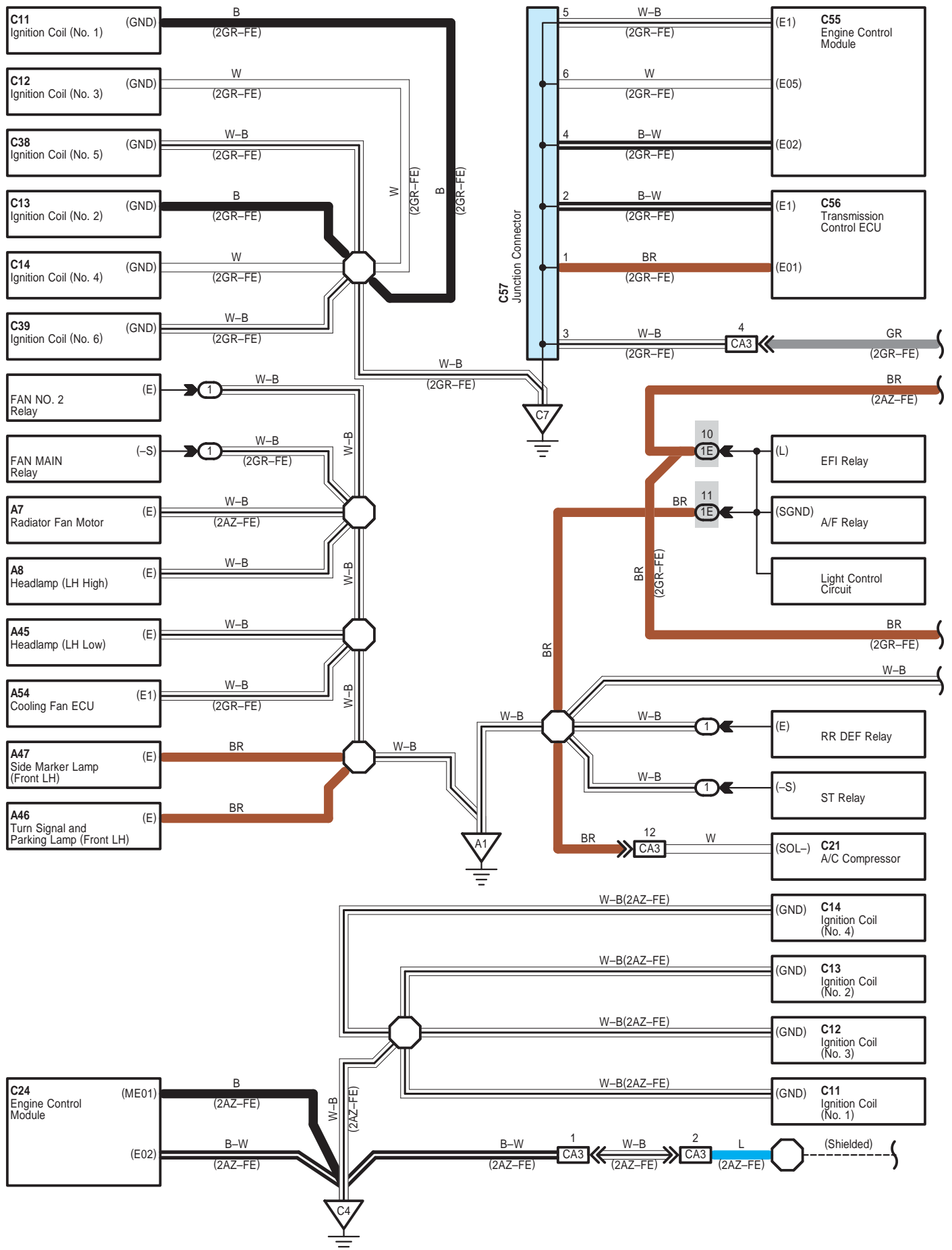

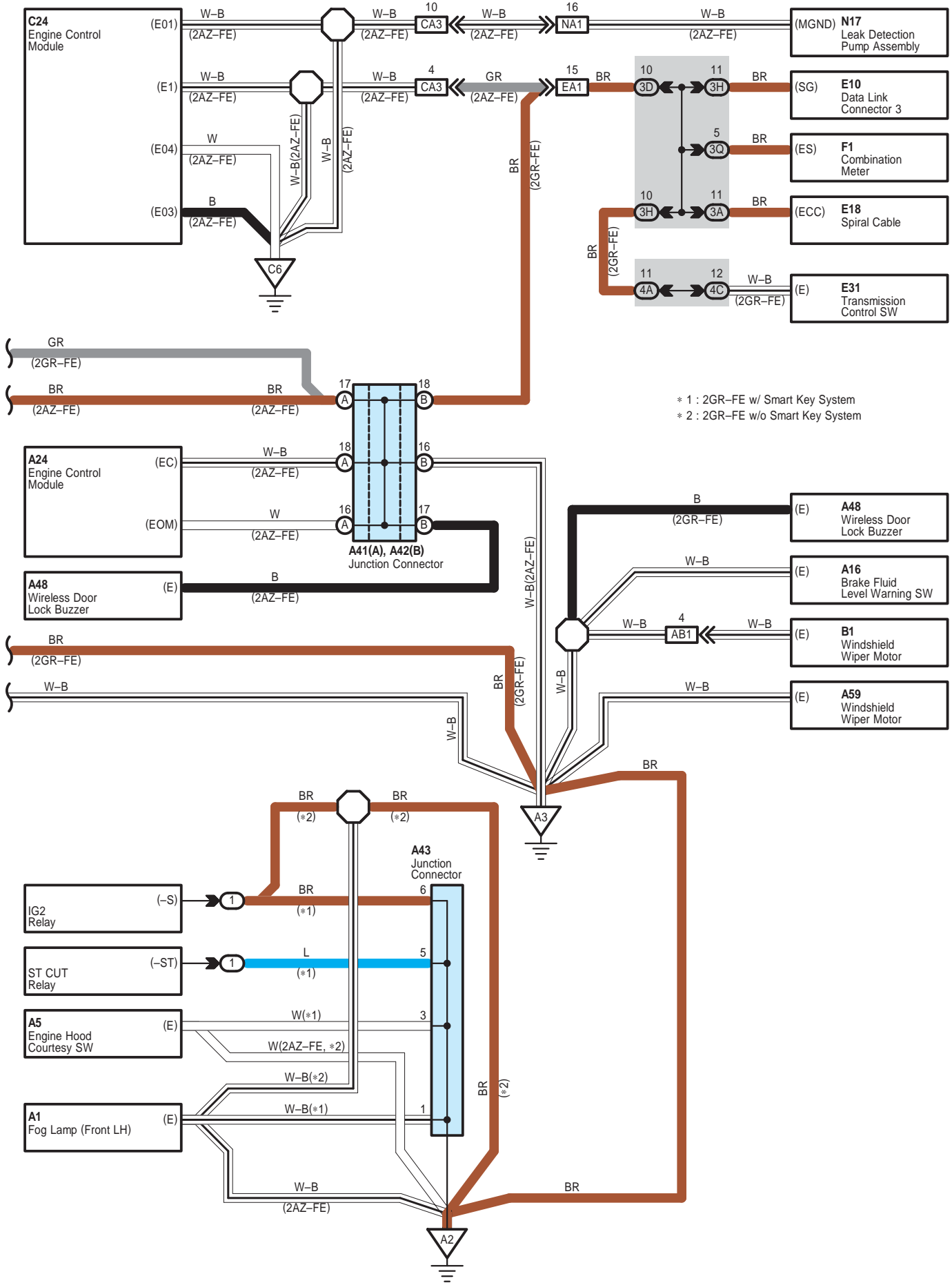

\* 1 : 2GR-FE w/ Smart Key System  
 \* 2 : 2GR-FE w/o Smart Key System

# I GROUND POINT

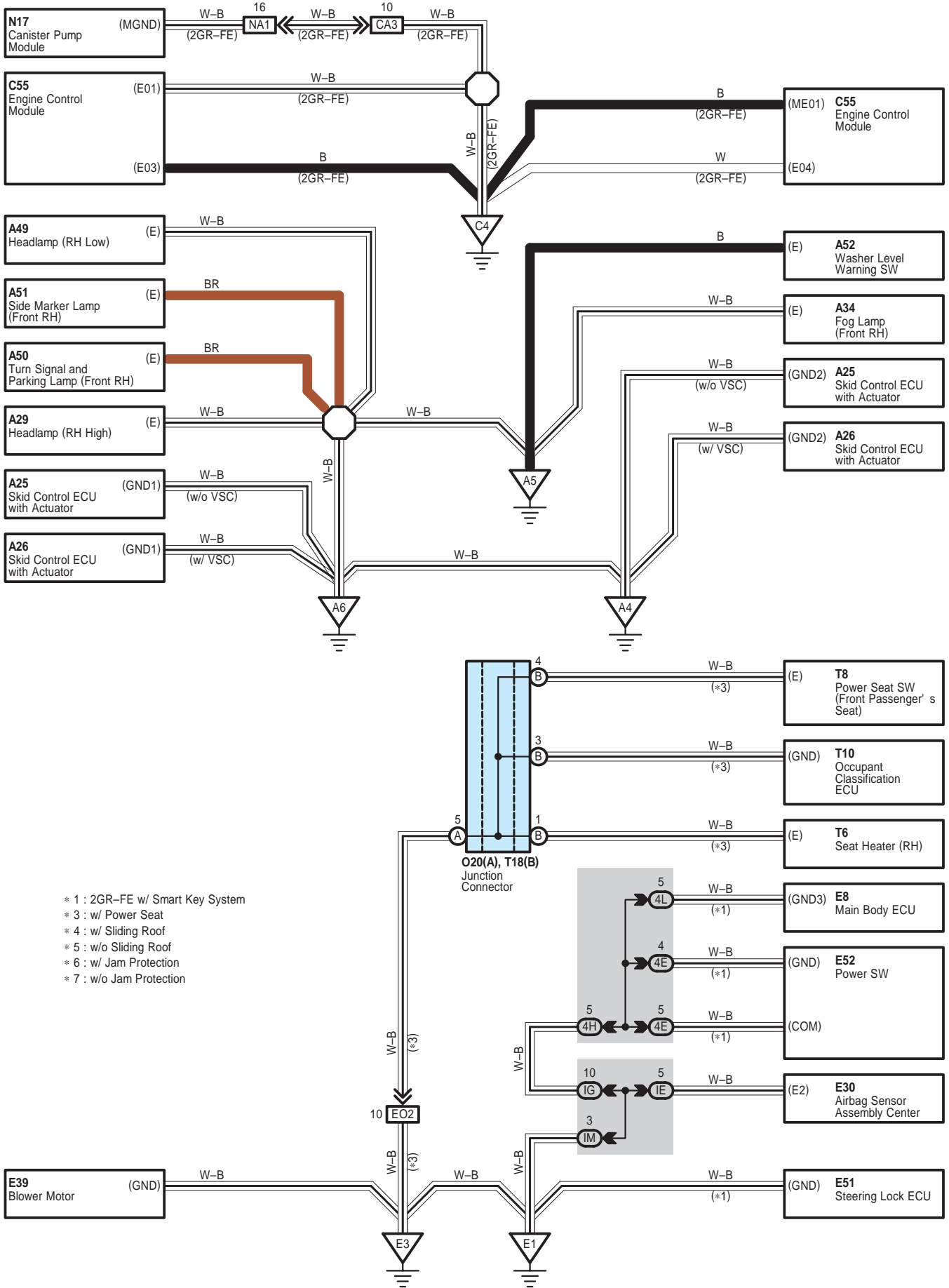

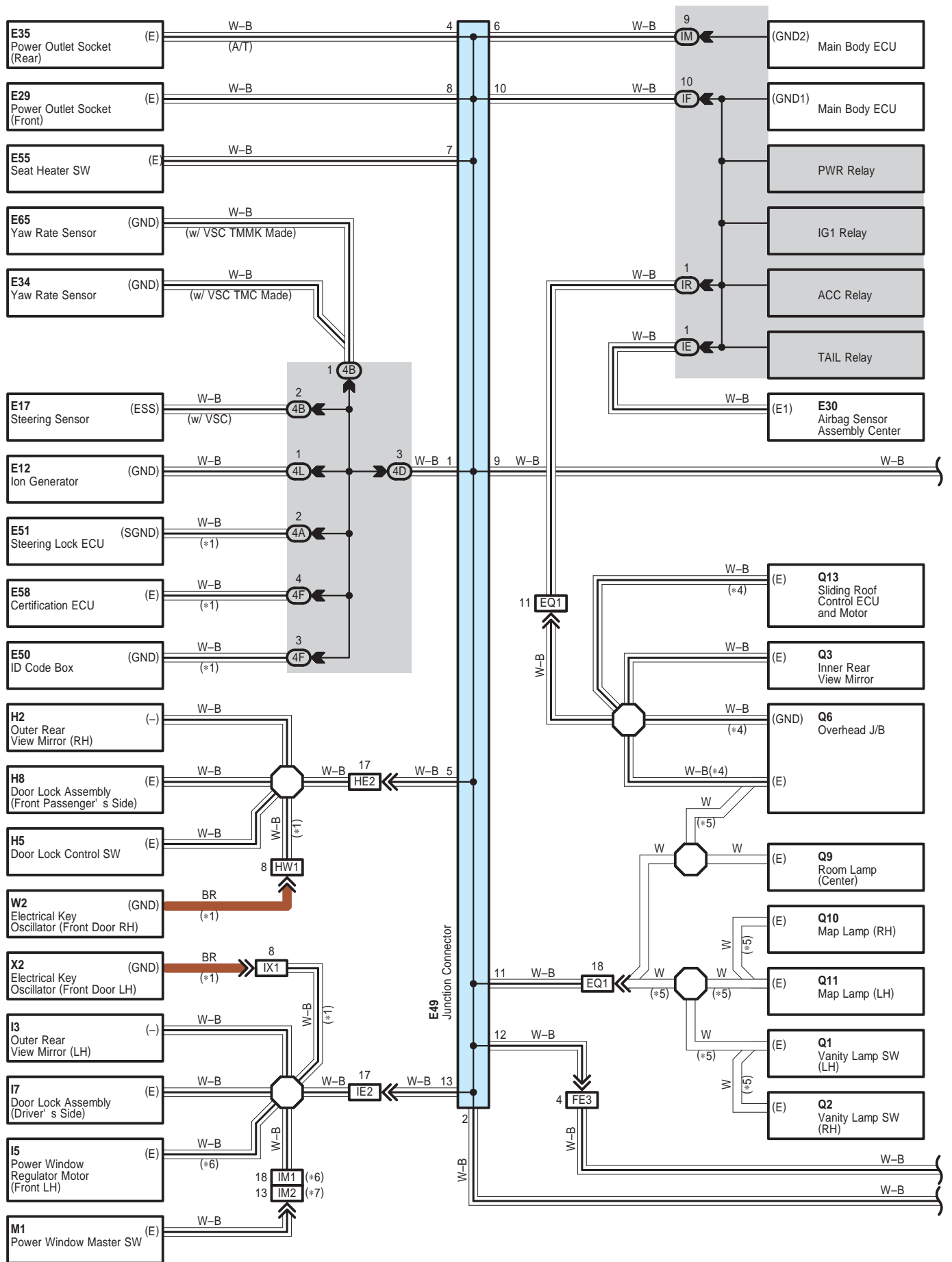



# I GROUND POINT

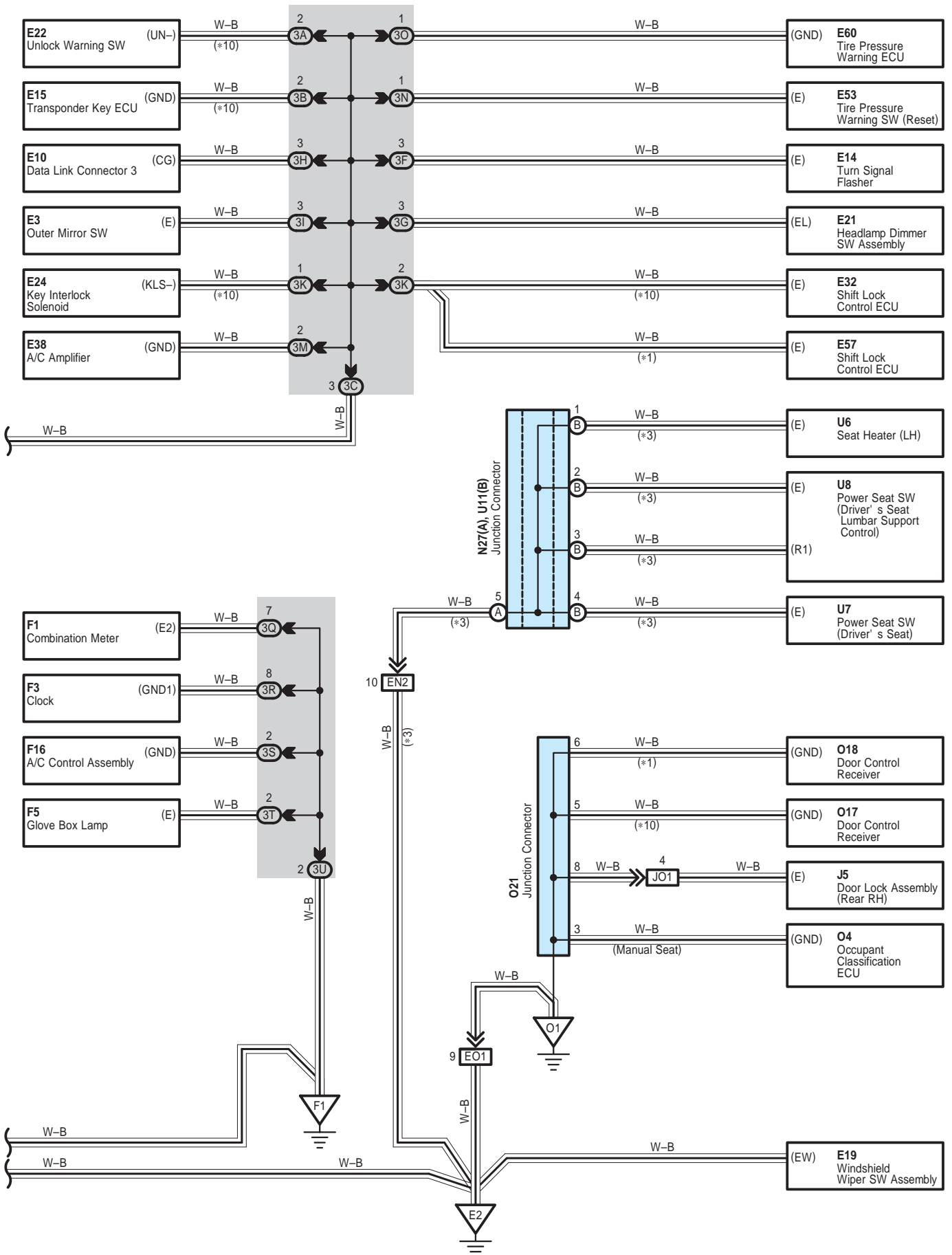

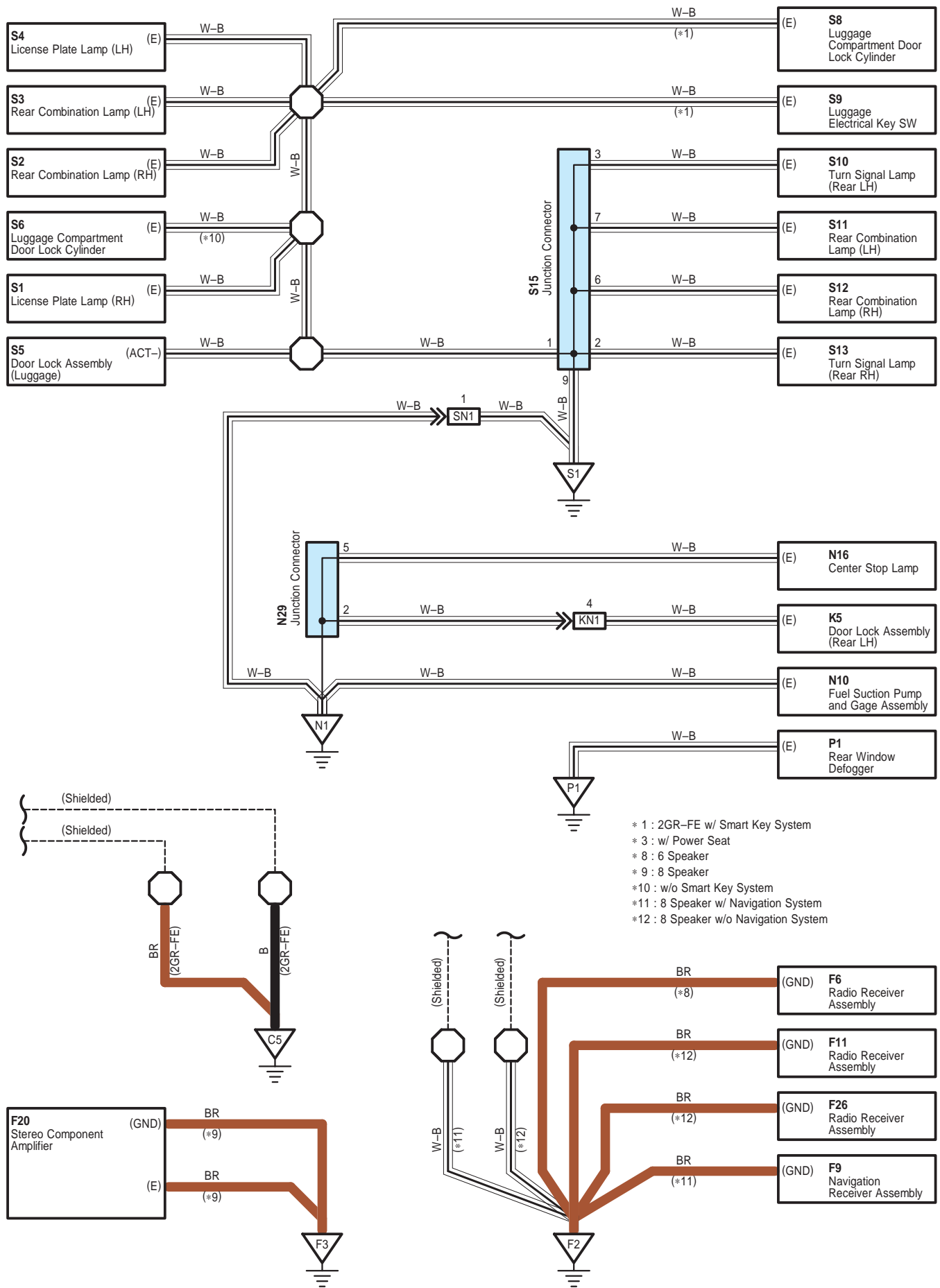

# I GROUND POINT

## ○ : Parts Location

| Code |   | See Page    | Code |   | See Page | Code |   | See Page |
|------|---|-------------|------|---|----------|------|---|----------|
| A41  | A | 59          | E49  |   | 57       | O21  |   | 60       |
| A42  | B | 59          | N27  | A | 62 (*1)  | S15  |   | 61       |
| A43  |   | 49 (2GR-FE) | N29  |   | 60       | T18  | B | 62 (*1)  |
| C57  |   | 51 (2GR-FE) | O20  | A | 62 (*1)  | U11  | B | 62 (*1)  |

## ○ : Relay Blocks

| Code | See Page | Relay Blocks (Relay Block Location)       |
|------|----------|---|
| 1    | 22       | Engine Room R/B (Engine Compartment Left) |

## ○ : Junction Block and Wire Harness Connector

| Code | See Page | Junction Block and Wire Harness (Connector Location)                   |
|------|----------|--|
| 1E   | 25       | Engine Room Main Wire and Engine Room J/B (Engine Compartment Left)    |
| 3A   | 36       | Instrument Panel Wire and J/B No.3 (Behind the Combination Meter)      |
| 3B   |          |  |
| 3C   |          |  |
| 3D   |          |  |
| 3F   |          |  |
| 3G   |          |  |
| 3H   |          |  |
| 3I   |          |  |
| 3K   |          |  |
| 3M   |          |  |
| 3N   |          |  |
| 3O   | 36       | Instrument Panel No.2 Wire and J/B No.3 (Behind the Combination Meter) |
| 3Q   |          |  |
| 3R   |          |  |
| 3S   |          |  |
| 3T   |          |  |
| 3U   | 42       | Instrument Panel Wire and J/B No.4 (Instrument Panel Brace Center)     |
| 4A   |          |  |
| 4B   |          |  |
| 4C   |          |  |
| 4D   |          |  |
| 4E   |          |  |
| 4F   |          |  |
| 4H   | 30       | Instrument Panel Wire and Instrument Panel J/B (Cowl Side Left)        |
| 4L   |          |  |
| IE   |          |  |
| IF   |          |  |
| IG   |          |  |
| IM   | 30       |  |
| IR   |          |  |

\* 1 : w/ Power Seat      \* 2 : w/o Power Seat

 : Connector Joining Wire Harness and Wire Harness

| Code | See Page    | Joining Wire Harness and Wire Harness (Connector Location)                                |
|------|-------------|---|
| AB1  | 64 (2GR-FE) | Engine Room Main Wire and Engine Room No.2 Wire (Near the Windshield Wiper Motor)         |
|      | 65 (2AZ-FE) |   |
| CA3  | 64 (2GR-FE) | Engine Wire and Engine Room Main Wire (Inside of the Engine Room R/B and Engine Room J/B) |
|      | 65 (2AZ-FE) |   |
| EA1  | 66          | Instrument Panel Wire and Engine Room Main Wire (Left Kick Panel)                         |
| EN2  | 66          | Instrument Panel Wire and Floor Wire (Left Kick Panel)                                    |
| EO1  | 66          | Instrument Panel Wire and Floor No.2 Wire (Right Kick Panel)                              |
| EO2  |             |   |
| EQ1  | 66          | Instrument Panel Wire and Roof Wire (Lower Part of Front Pillar LH)                       |
| FE3  | 66          | Instrument Panel No.2 Wire and Instrument Panel Wire (Instrument Panel Center)            |
| HE2  | 66          | Front Door RH Wire and Instrument Panel Wire (Right Kick Panel)                           |
| HW1  | 67          | Front Door RH Wire and Electrical Key Wire Harness RH (Inside of the Front Door RH)       |
| IE2  | 66          | Front Door LH Wire and Instrument Panel Wire (Left Kick Panel)                            |
| IM1  | 67          | Front Door LH Wire and Front Door LH No.2 Wire (Inside of the Front Door LH)              |
| IM2  |             |   |
| IX1  | 67          | Front Door LH Wire and Electrical Key Wire Harness LH (Inside of the Front Door LH)       |
| JO1  | 67          | Rear Door No.1 Wire and Floor No.2 Wire (Right Center Pillar)                             |
| KN1  | 67          | Rear Door No.2 Wire and Floor Wire (Left Center Pillar)                                   |
| NA1  | 66          | Floor Wire and Engine Room Main Wire (Left Kick Panel)                                    |
| QR1  | 67          | Roof Wire and Roof No.2 Wire (Near the Overhead J/B)                                      |
| SN1  | 67          | Luggage Room Wire and Floor Wire (Luggage Room Left)                                      |

 : Ground Points

| Code | See Page    | Ground Points Location                  |
|------|-------------|---|
| A1   | 64 (2GR-FE) | Front Left Fender                       |
|      | 65 (2AZ-FE) |   |
| A2   | 64 (2GR-FE) |   |
|      | 65 (2AZ-FE) |   |
| A3   | 66          | Left Cowl Side Panel                    |
| A4   | 64 (2GR-FE) | Near the Skid Control ECU with Actuator |
|      | 65 (2AZ-FE) |   |
| A5   | 64 (2GR-FE) | Front Right Fender                      |
|      | 65 (2AZ-FE) |   |
| A6   | 66          | Right Cowl Side Panel                   |
| C4   | 64 (2GR-FE) | Cylinder Head                           |
|      | 65 (2AZ-FE) | Cylinder Block                          |
| C5   | 64 (2GR-FE) | Right Side of the Cylinder Block        |
| C6   | 65 (2AZ-FE) | Cylinder Block                          |
| C7   | 64 (2GR-FE) | Left Side of the Cylinder Block         |
| E1   | 66          | Instrument Panel Left                   |
| E2   | 66          | Instrument Panel Brace LH               |
| E3   | 66          | Instrument Panel Right                  |
| F1   | 66          | Instrument Panel Left                   |
| F2   | 66          | Instrument Panel Brace RH               |
| F3   | 66          | Under the Front Passenger's Seat        |
| N1   | 67          | Left Rear Quarter Panel                 |
| O1   | 67          | Right Rear Quarter Panel                |
| P1   |             |   |
| S1   | 67          | Lower Back Panel Center                 |

# J POWER SOURCE (Current Flow Chart)

The chart below shows the route by which current flows from the battery to each electrical source (Fusible Link, Circuit Breaker, Fuse, etc.) and other Parts.

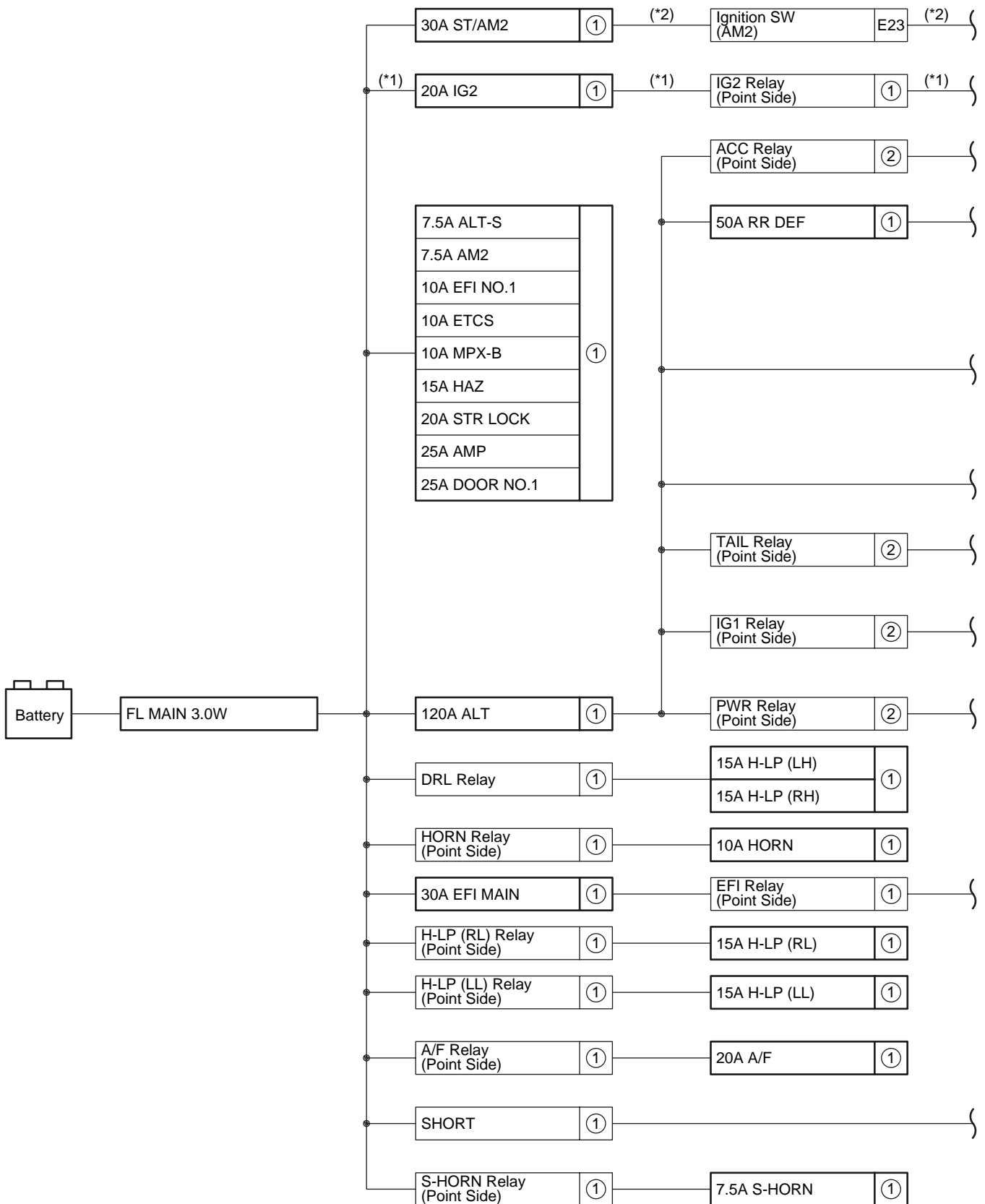

① : Engine Room R/B and Engine Room J/B (See Page 22)

② : Instrument Panel J/B (See Page 30)

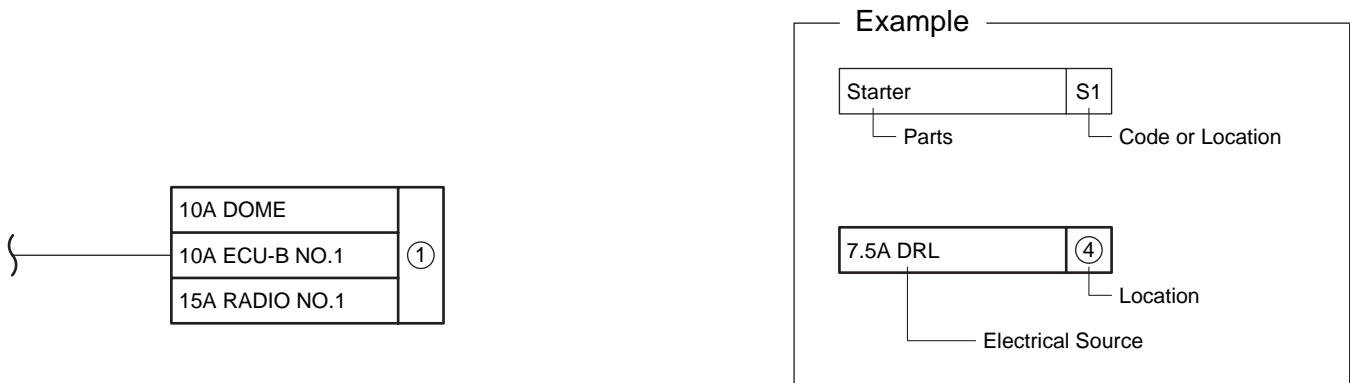
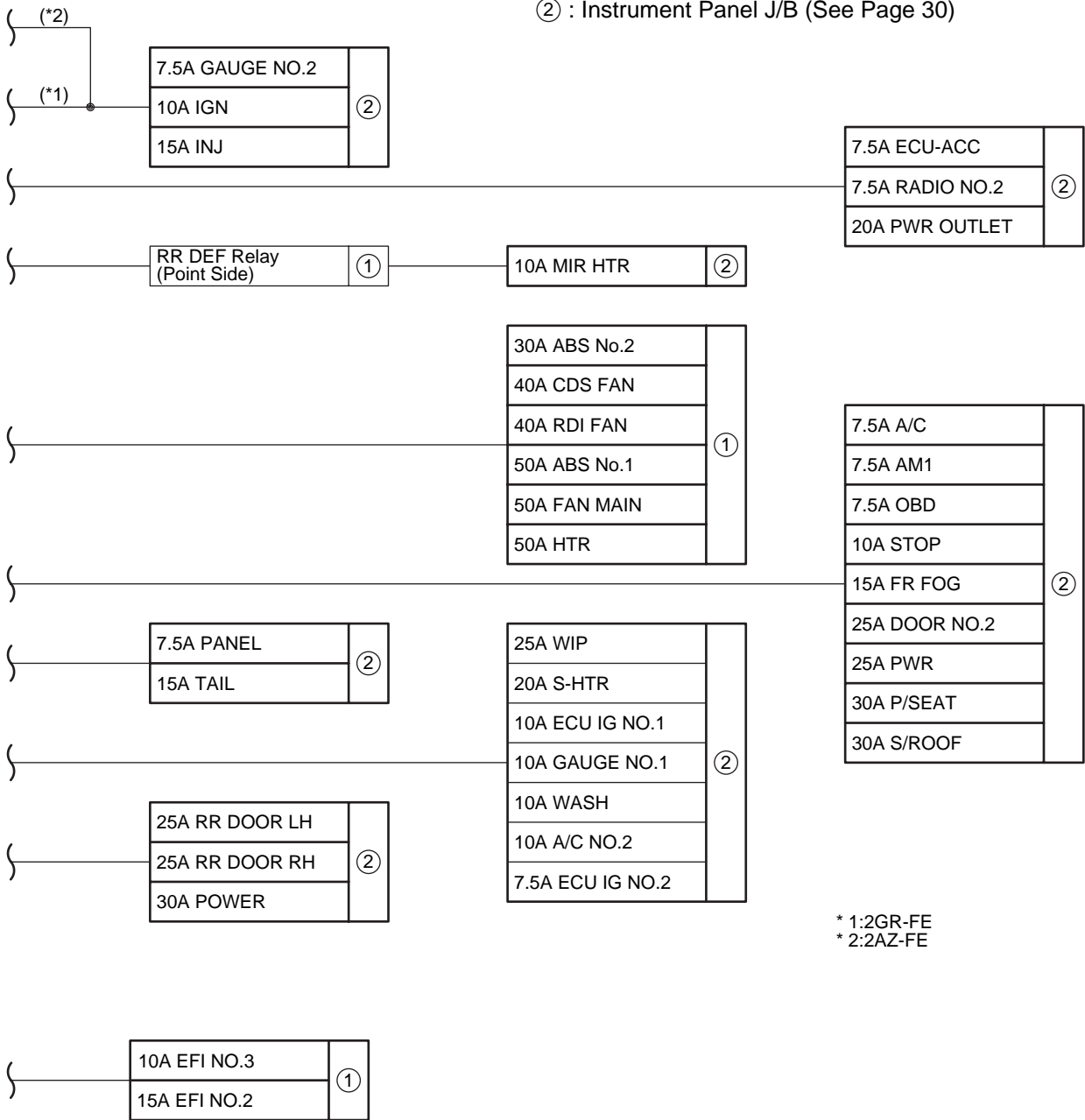

## J POWER SOURCE (Current Flow Chart)

### Engine Room R/B and Engine Room J/B (See Page 22)

| Fuse  |            | System  | Page |
|---|------------|---|------|
| 7.5A  | ALT-S      | Charging  | 100  |
| 7.5A  | AM2        | Electronically Controlled Transmission and A/T Indicator (2GR-FE) | 300  |
|   |            | Engine Control (2GR-FE)   | 108  |
|   |            | Ignition (2GR-FE)   | 102  |
|   |            | Smart Key System  | 78   |
| 7.5A  | S-HORN     | Smart Key System  | 78   |
|   |            | Theft Deterrent   | 230  |
| 10A   | DOME       | ABS (w/ VSC), TRAC and VSC (TMC Made)                             | 242  |
|   |            | ABS (w/ VSC), TRAC and VSC (TMMK Made)                            | 252  |
|   |            | ABS (w/o VSC)   | 262  |
|   |            | Air Conditioning  | 386  |
|   |            | Audio System (6 Speaker)  | 360  |
|   |            | Audio System (8 Speaker w/o Navigation System)                    | 354  |
|   |            | Clock   | 202  |
|   |            | Combination Meter   | 364  |
|   |            | Cooling Fan (2GR-FE)  | 374  |
|   |            | Cruise Control (2AZ-FE)   | 292  |
|   |            | Cruise Control (2GR-FE)   | 282  |
|   |            | Door Lock Control and Luggage Compartment Door Opener             | 214  |
|   |            | Electronically Controlled Transmission and A/T Indicator (2AZ-FE) | 312  |
|   |            | Electronically Controlled Transmission and A/T Indicator (2GR-FE) | 300  |
|   |            | Engine Control (2AZ-FE)   | 126  |
|   |            | Engine Control (2GR-FE)   | 108  |
|   |            | Fog Light   | 150  |
|   |            | Garage Door Opener  | 336  |
|   |            | Headlight   | 144  |
|   |            | Interior Light  | 164  |
|   |            | Key Reminder (w/o Smart Key System) and Seat Belt Warning         | 190  |
|   |            | Navigation System and Audio System (8 Speaker)                    | 346  |
|   |            | Radiator Fan and Condenser Fan (2AZ-FE)                           | 380  |
|   |            | Sliding Roof  | 330  |
|   |            | Smart Key System  | 78   |
|   |            | SRS   | 273  |
|   |            | Taillight and Illumination  | 172  |
| Theft Deterrent                                   | 230        |   |      |
| Tire Pressure Warning System                      | 270        |   |      |
| Wireless Door Lock Control (w/o Smart Key System) | 224        |   |      |
| 10A   | ECU-B NO.1 | ABS (w/ VSC), TRAC and VSC (TMC Made)                             | 242  |
|   |            | ABS (w/ VSC), TRAC and VSC (TMMK Made)                            | 252  |
|   |            | Automatic Light Control and Light Auto Turn Off System            | 160  |
|   |            | Door Lock Control and Luggage Compartment Door Opener             | 214  |
|   |            | Fog Light   | 150  |

\* These are the page numbers of the first page on which the related system is shown.

| Fuse |            | System  | Page |
|------|------------|---|------|
| 10A  | ECU-B NO.1 | Headlight   | 144  |
|      |            | Interior Light  | 164  |
|      |            | Key Reminder (w/o Smart Key System) and Seat Belt Warning         | 190  |
|      |            | Power Window  | 206  |
|      |            | Sliding Roof  | 330  |
|      |            | SRS   | 273  |
|      |            | Taillight and Illumination  | 172  |
|      |            | Theft Deterrent   | 230  |
|      |            | Wireless Door Lock Control (w/o Smart Key System)                 | 224  |
| 10A  | EFI NO.1   | Cruise Control (2AZ-FE)   | 292  |
|      |            | Cruise Control (2GR-FE)   | 282  |
|      |            | Electronically Controlled Transmission and A/T Indicator (2AZ-FE) | 312  |
|      |            | Electronically Controlled Transmission and A/T Indicator (2GR-FE) | 300  |
|      |            | Engine Control (2AZ-FE)   | 126  |
|      |            | Engine Control (2GR-FE)   | 108  |
|      |            | Engine Immobiliser System (w/o Smart Key System)                  | 138  |
|      |            | Smart Key System  | 78   |
| 10A  | EFI NO.3   | Electronically Controlled Transmission and A/T Indicator (2AZ-FE) | 312  |
|      |            | Electronically Controlled Transmission and A/T Indicator (2GR-FE) | 300  |
|      |            | Engine Control (2AZ-FE)   | 126  |
|      |            | Engine Control (2GR-FE)   | 108  |
| 10A  | ETCS       | Cruise Control (2AZ-FE)   | 292  |
|      |            | Cruise Control (2GR-FE)   | 282  |
|      |            | Electronically Controlled Transmission and A/T Indicator (2AZ-FE) | 312  |
|      |            | Electronically Controlled Transmission and A/T Indicator (2GR-FE) | 300  |
|      |            | Engine Control (2AZ-FE)   | 126  |
|      |            | Engine Control (2GR-FE)   | 108  |
| 10A  | HORN       | Horn  | 204  |
|      |            | Smart Key System  | 78   |
|      |            | Theft Deterrent   | 230  |
| 10A  | MPX-B      | ABS (w/ VSC), TRAC and VSC (TMC Made)                             | 242  |
|      |            | ABS (w/ VSC), TRAC and VSC (TMMK Made)                            | 252  |
|      |            | ABS (w/o VSC)   | 262  |
|      |            | Air Conditioning  | 386  |
|      |            | Audio System (6 Speaker)  | 360  |
|      |            | Audio System (8 Speaker w/o Navigation System)                    | 354  |
|      |            | Combination Meter   | 364  |
|      |            | Cooling Fan (2GR-FE)  | 374  |
|      |            | Cruise Control (2AZ-FE)   | 292  |
|      |            | Cruise Control (2GR-FE)   | 282  |
|      |            | Door Lock Control and Luggage Compartment Door Opener             | 214  |
|      |            | Electronically Controlled Transmission and A/T Indicator (2AZ-FE) | 312  |
|      |            | Electronically Controlled Transmission and A/T Indicator (2GR-FE) | 300  |
|      |            | Engine Control (2AZ-FE)   | 126  |

\* These are the page numbers of the first page on which the related system is shown.



## J POWER SOURCE (Current Flow Chart)

| Fuse |            | System  | Page |
|------|------------|---|------|
| 10A  | MPX-B      | Engine Control (2GR-FE)   | 108  |
|      |            | Fog Light   | 150  |
|      |            | Headlight   | 144  |
|      |            | Key Reminder (w/o Smart Key System) and Seat Belt Warning         | 190  |
|      |            | Navigation System and Audio System (8 Speaker)                    | 346  |
|      |            | Radiator Fan and Condenser Fan (2AZ-FE)                           | 380  |
|      |            | Sliding Roof  | 330  |
|      |            | Smart Key System  | 78   |
|      |            | SRS   | 273  |
|      |            | Taillight and Illumination  | 172  |
|      |            | Tire Pressure Warning System                                      | 270  |
| 15A  | EFI NO.2   | Cruise Control (2AZ-FE)   | 292  |
|      |            | Cruise Control (2GR-FE)   | 282  |
|      |            | Electronically Controlled Transmission and A/T Indicator (2AZ-FE) | 312  |
|      |            | Electronically Controlled Transmission and A/T Indicator (2GR-FE) | 300  |
|      |            | Engine Control (2AZ-FE)   | 126  |
|      |            | Engine Control (2GR-FE)   | 108  |
| 15A  | HAZ        | Turn Signal and Hazard Warning Light                              | 182  |
| 15A  | H-LP (LH)  | Headlight   | 144  |
| 15A  | H-LP (LL)  | Headlight   | 144  |
| 15A  | H-LP (RH)  | Headlight   | 144  |
| 15A  | H-LP (RL)  | Headlight   | 144  |
| 15A  | RADIO NO.1 | Audio System (6 Speaker)  | 360  |
|      |            | Audio System (8 Speaker w/o Navigation System)                    | 354  |
|      |            | Navigation System and Audio System (8 Speaker)                    | 346  |
| 20A  | A/F        | Engine Control (2GR-FE)   | 108  |
| 20A  | IG2        | Combination Meter   | 364  |
|      |            | Engine Control (2GR-FE)   | 108  |
|      |            | Ignition (2GR-FE)   | 102  |
|      |            | Smart Key System  | 78   |
| 20A  | STR LOCK   | Smart Key System  | 78   |
| 25A  | AMP        | Audio System (8 Speaker w/o Navigation System)                    | 354  |
|      |            | Navigation System and Audio System (8 Speaker)                    | 346  |
| 25A  | DOOR NO.1  | Automatic Light Control and Light Auto Turn Off System            | 160  |
|      |            | Door Lock Control and Luggage Compartment Door Opener             | 214  |
|      |            | Fog Light   | 150  |
|      |            | Headlight   | 144  |
|      |            | Interior Light  | 164  |
|      |            | Power Window  | 206  |
|      |            | Sliding Roof  | 330  |
|      |            | Smart Key System  | 78   |
|      |            | Taillight and Illumination  | 172  |
|      |            | Theft Deterrent   | 230  |

\* These are the page numbers of the first page on which the related system is shown.

| Fuse |          | System  | Page |
|------|----------|---|------|
| 30A  | ABS No.2 | ABS (w/ VSC), TRAC and VSC (TMC Made)                             | 242  |
|      |          | ABS (w/ VSC), TRAC and VSC (TMMK Made)                            | 252  |
|      |          | ABS (w/o VSC)   | 262  |
| 30A  | EFI MAIN | Cruise Control (2AZ-FE)   | 292  |
|      |          | Cruise Control (2GR-FE)   | 282  |
|      |          | Electronically Controlled Transmission and A/T Indicator (2AZ-FE) | 312  |
|      |          | Electronically Controlled Transmission and A/T Indicator (2GR-FE) | 300  |
|      |          | Engine Control (2AZ-FE)   | 126  |
|      |          | Engine Control (2GR-FE)   | 108  |
| 30A  | S/ROOF   | Sliding Roof  | 330  |
| 30A  | ST/AM2   | Engine Control (2GR-FE)   | 108  |
|      |          | Ignition (2GR-FE)   | 102  |
|      |          | Smart Key System  | 78   |
|      |          | Starting (w/o Smart Key System)                                   | 96   |
| 40A  | CDS FAN  | Radiator Fan and Condenser Fan (2AZ-FE)                           | 380  |
| 40A  | RDI FAN  | Radiator Fan and Condenser Fan (2AZ-FE)                           | 380  |
| 50A  | ABS No.1 | ABS (w/ VSC), TRAC and VSC (TMC Made)                             | 242  |
|      |          | ABS (w/ VSC), TRAC and VSC (TMMK Made)                            | 252  |
|      |          | ABS (w/o VSC)   | 262  |
| 50A  | FAN MAIN | Cooling Fan (2GR-FE)  | 374  |
| 50A  | HTR      | Air Conditioning  | 386  |
| 50A  | RR DEF   | Rear Window Defogger and Mirror Heater                            | 342  |
| 120A | ALT      | Automatic Light Control and Light Auto Turn Off System            | 160  |
|      |          | Charging  | 100  |
|      |          | Fog Light   | 150  |
|      |          | Power Window  | 206  |
|      |          | Starting (w/o Smart Key System)                                   | 96   |
|      |          | Taillight and Illumination  | 172  |
|      |          | Theft Deterrent   | 230  |

### Instrument Panel J/B (See Page 30)

| Fuse |             | System  | Page |
|------|-------------|---|------|
| 7.5A | A/C         | Air Conditioning  | 386  |
| 7.5A | AM1         | Electronically Controlled Transmission and A/T Indicator (2GR-FE) | 300  |
|      |             | Engine Control (2AZ-FE)   | 126  |
|      |             | Engine Control (2GR-FE)   | 108  |
|      |             | Starting (w/o Smart Key System)                                   | 96   |
| 7.5A | ECU IG NO.2 | ABS (w/ VSC), TRAC and VSC (TMC Made)                             | 242  |
|      |             | ABS (w/ VSC), TRAC and VSC (TMMK Made)                            | 252  |
|      |             | ABS (w/o VSC)   | 262  |
|      |             | Cruise Control (2AZ-FE)   | 292  |
|      |             | Cruise Control (2GR-FE)   | 282  |
|      |             | Electronically Controlled Transmission and A/T Indicator (2GR-FE) | 300  |
|      |             | Shift Lock  | 320  |

\* These are the page numbers of the first page on which the related system is shown.

## J POWER SOURCE (Current Flow Chart)

| Fuse                         |            | System  | Page |
|------------------------------|------------|---|------|
| 7.5A                         | ECU-ACC    | Automatic Light Control and Light Auto Turn Off System            | 160  |
|                              |            | Clock   | 202  |
|                              |            | Door Lock Control and Luggage Compartment Door Opener             | 214  |
|                              |            | Fog Light   | 150  |
|                              |            | Headlight   | 144  |
|                              |            | Interior Light  | 164  |
|                              |            | Power Window  | 206  |
|                              |            | Remote Control Mirror   | 340  |
|                              |            | Shift Lock  | 320  |
|                              |            | Sliding Roof  | 330  |
|                              |            | Smart Key System  | 78   |
|                              |            | Taillight and Illumination  | 172  |
|                              |            | Theft Deterrent   | 230  |
|                              |            | Wireless Door Lock Control (w/o Smart Key System)                 | 224  |
| 7.5A                         | GAUGE NO.2 | ABS (w/ VSC), TRAC and VSC (TMC Made)                             | 242  |
|                              |            | ABS (w/ VSC), TRAC and VSC (TMMK Made)                            | 252  |
|                              |            | ABS (w/o VSC)   | 262  |
|                              |            | Air Conditioning  | 386  |
|                              |            | Audio System (6 Speaker)  | 360  |
|                              |            | Audio System (8 Speaker w/o Navigation System)                    | 354  |
|                              |            | Charging  | 100  |
|                              |            | Combination Meter   | 364  |
|                              |            | Cooling Fan (2GR-FE)  | 374  |
|                              |            | Cruise Control (2AZ-FE)   | 292  |
|                              |            | Cruise Control (2GR-FE)   | 282  |
|                              |            | Door Lock Control and Luggage Compartment Door Opener             | 214  |
|                              |            | Electronically Controlled Transmission and A/T Indicator (2AZ-FE) | 312  |
|                              |            | Electronically Controlled Transmission and A/T Indicator (2GR-FE) | 300  |
|                              |            | Engine Control (2AZ-FE)   | 126  |
|                              |            | Engine Control (2GR-FE)   | 108  |
|                              |            | Fog Light   | 150  |
|                              |            | Headlight   | 144  |
|                              |            | Key Reminder (w/o Smart Key System) and Seat Belt Warning         | 190  |
|                              |            | Navigation System and Audio System (8 Speaker)                    | 346  |
|                              |            | Radiator Fan and Condenser Fan (2AZ-FE)                           | 380  |
|                              |            | Sliding Roof  | 330  |
|                              |            | Smart Key System  | 78   |
|                              |            | SRS   | 273  |
| Taillight and Illumination   | 172        |   |      |
| Tire Pressure Warning System | 270        |   |      |
| 7.5A                         | OBD        | Data Link Connector 3   | 140  |
| 7.5A                         | PANEL      | Taillight and Illumination  | 172  |

\* These are the page numbers of the first page on which the related system is shown.

| Fuse  |             | System  | Page |
|---|-------------|---|------|
| 7.5A  | RADIO NO.2  | Audio System (6 Speaker)  | 360  |
|   |             | Audio System (8 Speaker w/o Navigation System)                    | 354  |
|   |             | Navigation System and Audio System (8 Speaker)                    | 346  |
| 10A   | A/C NO.2    | Air Conditioning  | 386  |
|   |             | Cooling Fan (2GR-FE)  | 374  |
|   |             | Radiator Fan and Condenser Fan (2AZ-FE)                           | 380  |
|   |             | Rear Window Defogger and Mirror Heater                            | 342  |
| 10A   | ECU IG NO.1 | Automatic Glare-Resistant EC Mirror                               | 338  |
|   |             | Automatic Light Control and Light Auto Turn Off System            | 160  |
|   |             | Cooling Fan (2GR-FE)  | 374  |
|   |             | Door Lock Control and Luggage Compartment Door Opener             | 214  |
|   |             | Fog Light   | 150  |
|   |             | Headlight   | 144  |
|   |             | Interior Light  | 164  |
|   |             | Power Window  | 206  |
|   |             | Radiator Fan and Condenser Fan (2AZ-FE)                           | 380  |
|   |             | Sliding Roof  | 330  |
|   |             | Smart Key System  | 78   |
|   |             | Taillight and Illumination  | 172  |
|   |             | Theft Deterrent   | 230  |
| Tire Pressure Warning System                              | 270         |   |      |
| Wireless Door Lock Control (w/o Smart Key System)         | 224         |   |      |
| 10A   | GAUGE NO.1  | ABS (w/ VSC), TRAC and VSC (TMC Made)                             | 242  |
|   |             | ABS (w/ VSC), TRAC and VSC (TMMK Made)                            | 252  |
|   |             | ABS (w/o VSC)   | 262  |
|   |             | Back-Up Light   | 188  |
|   |             | Charging  | 100  |
|   |             | Cruise Control (2AZ-FE)   | 292  |
|   |             | Cruise Control (2GR-FE)   | 282  |
|   |             | Door Lock Control and Luggage Compartment Door Opener             | 214  |
|   |             | Electronically Controlled Transmission and A/T Indicator (2AZ-FE) | 312  |
|   |             | Electronically Controlled Transmission and A/T Indicator (2GR-FE) | 300  |
|   |             | Navigation System and Audio System (8 Speaker)                    | 346  |
|   |             | Shift Lock  | 320  |
| Turn Signal and Hazard Warning Light                      | 182         |   |      |
| 10A   | IGN         | Cruise Control (2AZ-FE)   | 292  |
|   |             | Cruise Control (2GR-FE)   | 282  |
|   |             | Electronically Controlled Transmission and A/T Indicator (2AZ-FE) | 312  |
|   |             | Electronically Controlled Transmission and A/T Indicator (2GR-FE) | 300  |
|   |             | Engine Control (2AZ-FE)   | 126  |
|   |             | Engine Control (2GR-FE)   | 108  |
|   |             | Engine Immobiliser System (w/o Smart Key System)                  | 138  |
| Key Reminder (w/o Smart Key System) and Seat Belt Warning | 190         |   |      |

\* These are the page numbers of the first page on which the related system is shown.

## J POWER SOURCE (Current Flow Chart)

| Fuse             |            | System  | Page |
|------------------|------------|---|------|
| 10A              | IGN        | Smart Key System  | 78   |
|                  |            | SRS   | 273  |
| 10A              | MIR HTR    | Rear Window Defogger and Mirror Heater                            | 342  |
| 10A              | STOP       | ABS (w/ VSC), TRAC and VSC (TMC Made)                             | 242  |
|                  |            | ABS (w/ VSC), TRAC and VSC (TMMK Made)                            | 252  |
|                  |            | ABS (w/o VSC)   | 262  |
|                  |            | Cruise Control (2AZ-FE)   | 292  |
|                  |            | Cruise Control (2GR-FE)   | 282  |
|                  |            | Electronically Controlled Transmission and A/T Indicator (2AZ-FE) | 312  |
|                  |            | Electronically Controlled Transmission and A/T Indicator (2GR-FE) | 300  |
|                  |            | Engine Control (2AZ-FE)   | 126  |
|                  |            | Engine Control (2GR-FE)   | 108  |
|                  |            | Shift Lock  | 320  |
| Smart Key System | 78         |   |      |
| Stop Light       | 186        |   |      |
| 10A              | WASH       | Wiper and Washer  | 196  |
| 15A              | FR FOG     | Fog Light   | 150  |
| 15A              | INJ        | Combination Meter   | 364  |
|                  |            | Engine Control (2AZ-FE)   | 126  |
|                  |            | Ignition (2AZ-FE)   | 106  |
| 15A              | TAIL       | Fog Light   | 150  |
|                  |            | Taillight and Illumination  | 172  |
| 20A              | PWR OUTLET | Power Outlet  | 200  |
| 20A              | S-HTR      | Seat Heater   | 328  |
| 25A              | DOOR NO.2  | Automatic Light Control and Light Auto Turn Off System            | 160  |
|                  |            | Door Lock Control and Luggage Compartment Door Opener             | 214  |
|                  |            | Fog Light   | 150  |
|                  |            | Headlight   | 144  |
|                  |            | Interior Light  | 164  |
|                  |            | Power Window  | 206  |
|                  |            | Sliding Roof  | 330  |
|                  |            | Smart Key System  | 78   |
|                  |            | Taillight and Illumination  | 172  |
| Theft Deterrent  | 230        |   |      |
| 25A              | PWR        | Power Window  | 206  |
| 25A              | RR DOOR LH | Power Window  | 206  |
| 25A              | RR DOOR RH | Power Window  | 206  |
| 25A              | WIP        | Wiper and Washer  | 196  |
| 30A              | POWER      | Power Window  | 206  |
| 30A              | P/SEAT     | Power Seat (Driver's Seat)  | 322  |
|                  |            | Power Seat (Front Passenger's Seat)                               | 326  |

\* These are the page numbers of the first page on which the related system is shown.



# K CONNECTOR LIST

**A1**  
Black

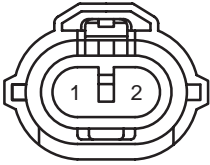

**A2**  
Black



**A3**  
Black



**A4**  
Black



**A5**  
Black



**A6**  
Gray



**A7**  
Black



**A8**  
Black

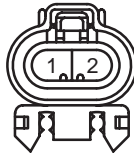

**A13**  
Yellow

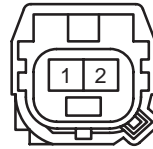

**A14**  
Black



**A16**  
Gray



**A17**  
Black

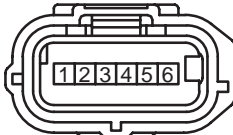

**A18**



**A19**  
Blue

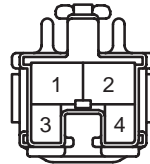

**A21**



**A22**  
Black



**A23**  
Black



**A24**  
Black

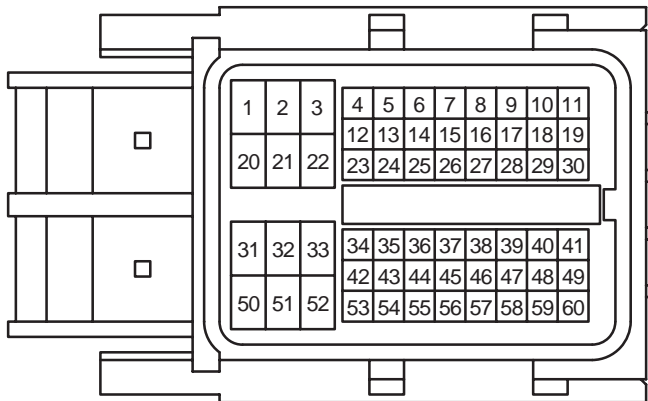

**A25**  
Black

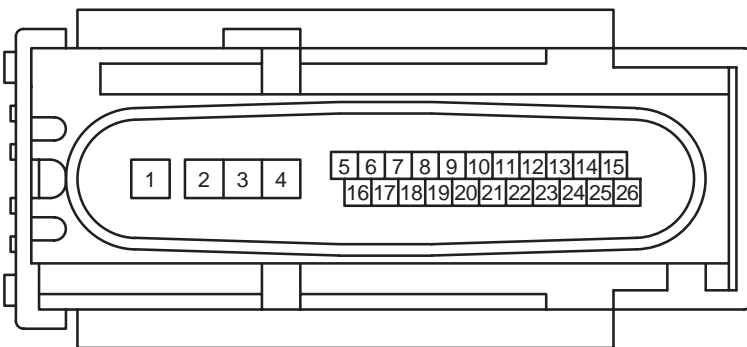

**A26**  
Black

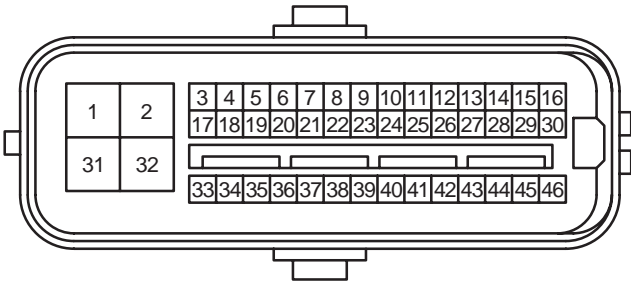

**A27**  
Black



**A28**  
Yellow

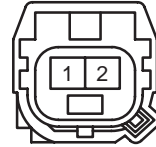

**A29**  
Black

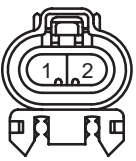

**A34**  
Black

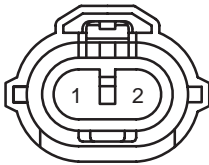

**A35**  
Gray



**A37**  
Black



**A40**  
Blue

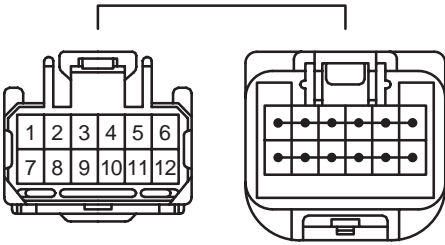

**A41**

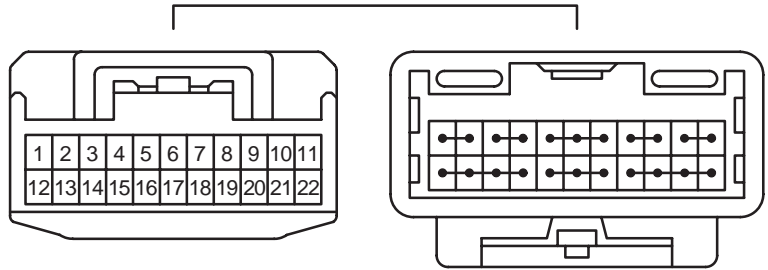

**A42**

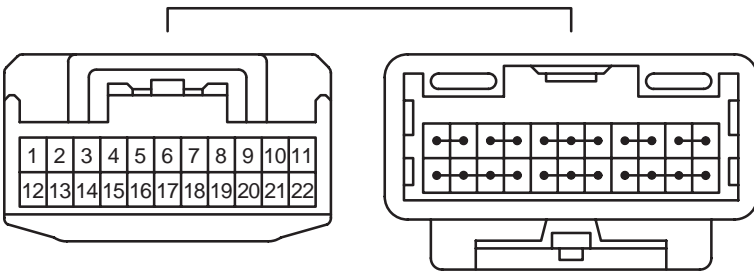

**A43**  
Gray

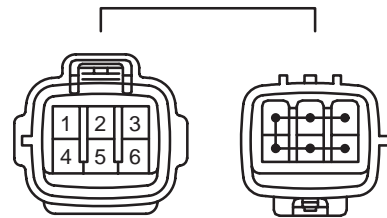

**A45**  
Black

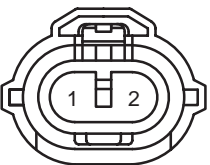

**A46**  
Gray



**A47**  
Black



**A48**  
Black



**A49**  
Black

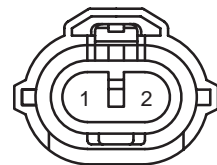



# K CONNECTOR LIST

**A50**  
Gray



**A51**  
Black



**A52**



**A53**  
Black

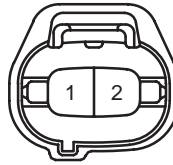

**A54**  
Black

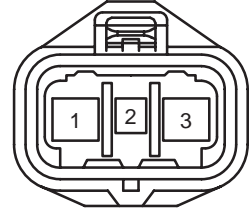

**A55**  
Black

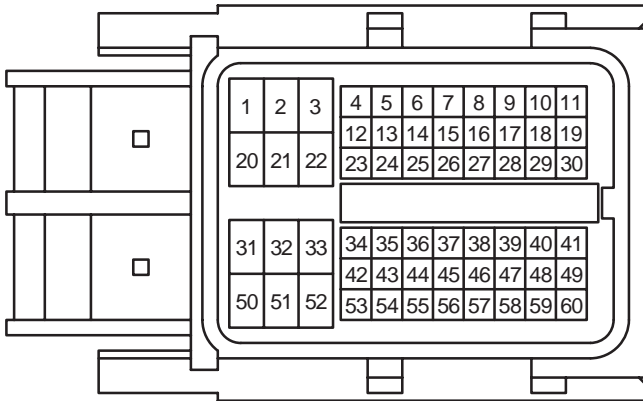

**A56**

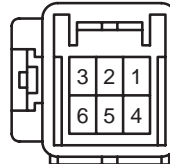

**A57**

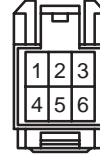

**A58**  
Black

**A59**  
Black

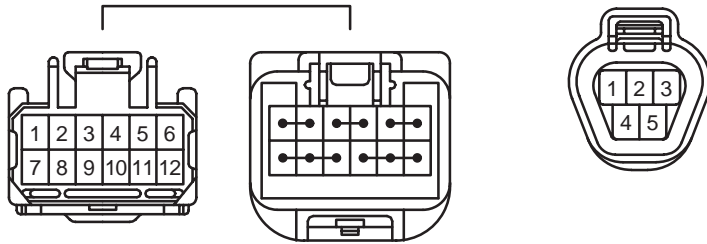

**A60**  
Black

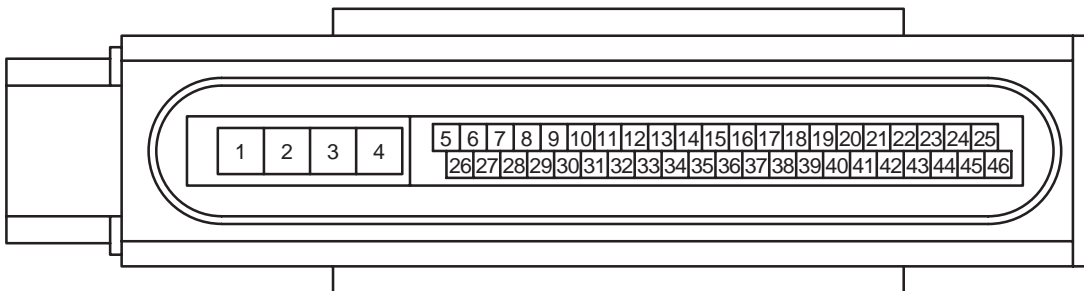

**B1**  
Black



**C1**  
Gray

**C2**  
Black

**C3**  
Black

**C4**  
Black

**C5**  
Black

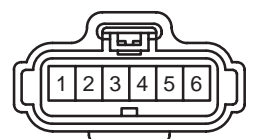
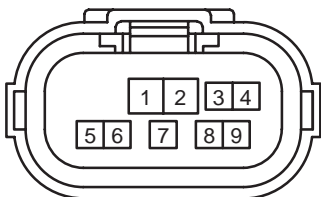

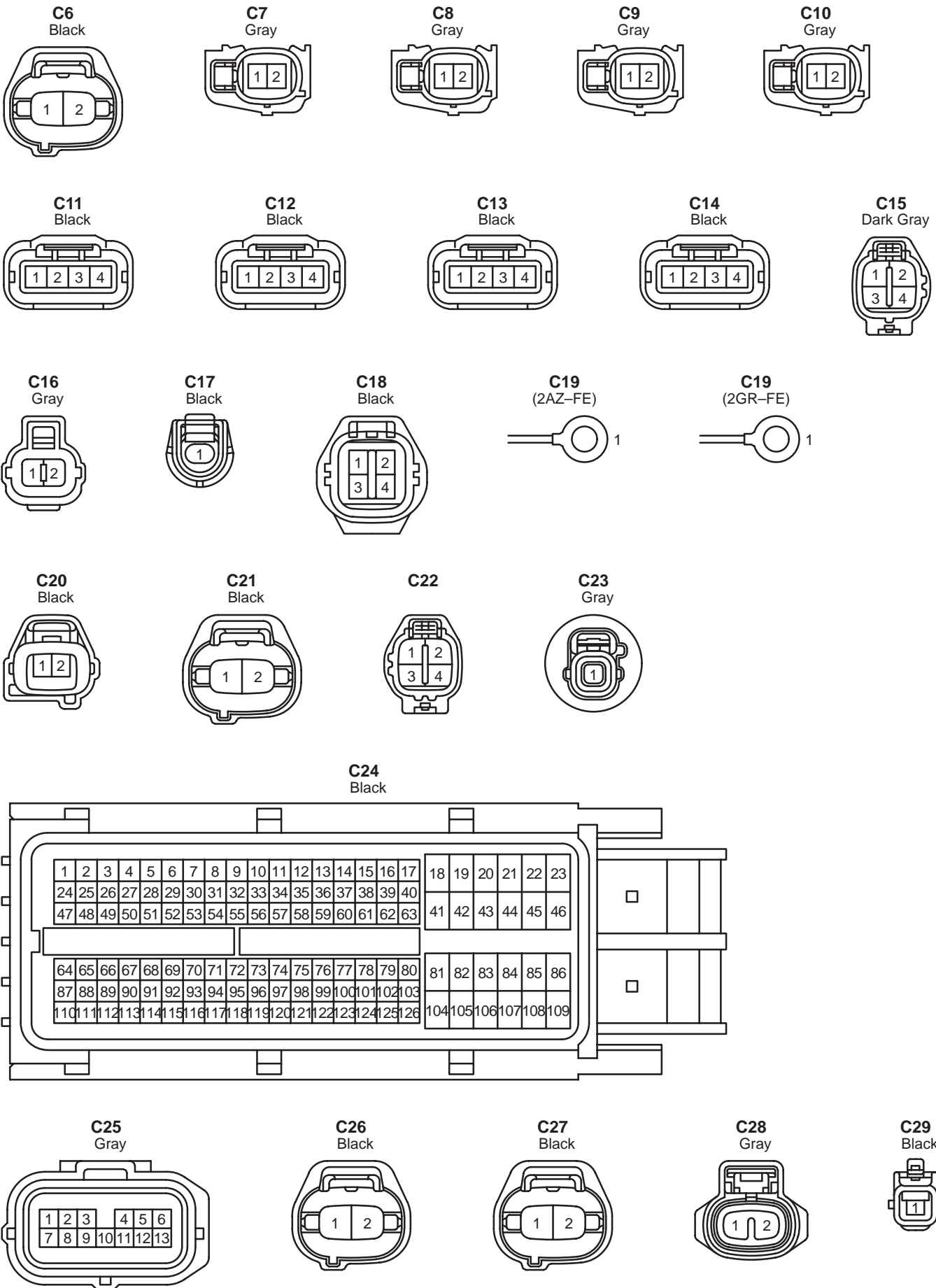

# K CONNECTOR LIST

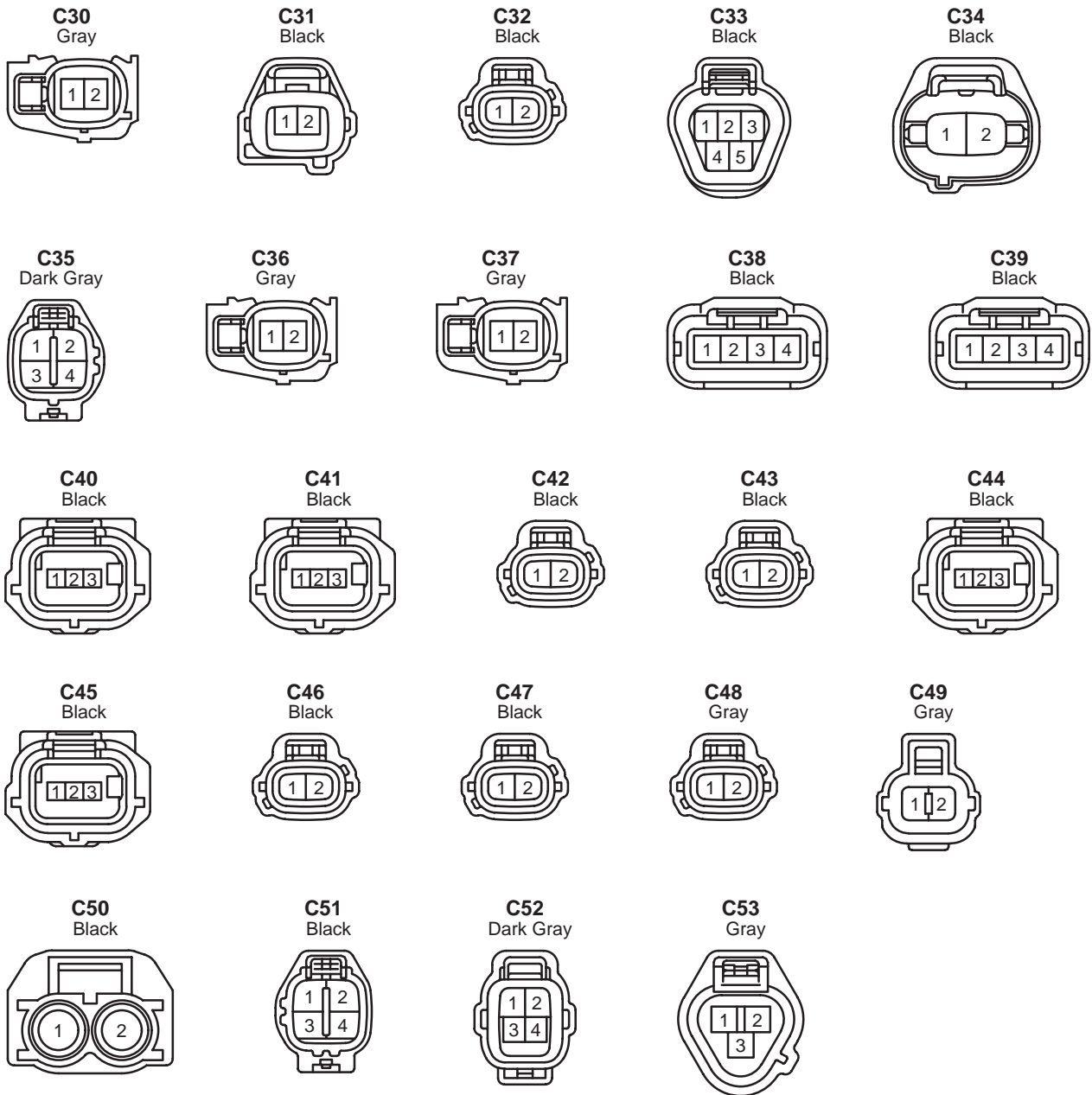

**C55**  
Black

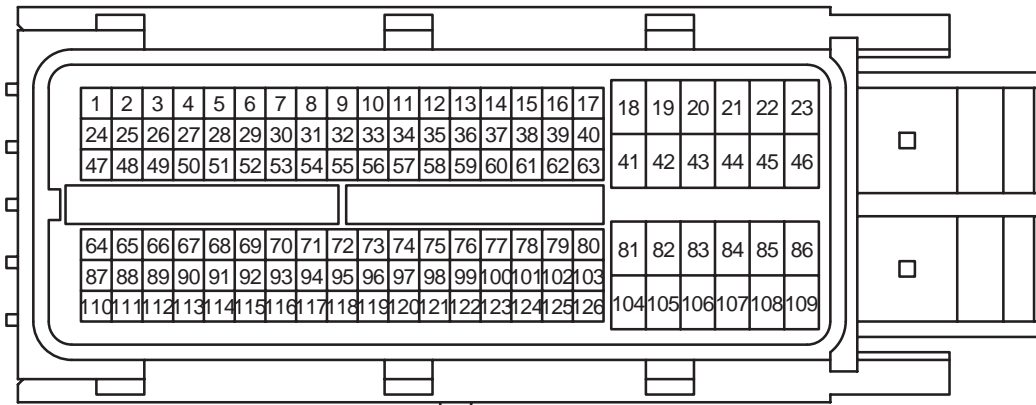

**C56**  
Black

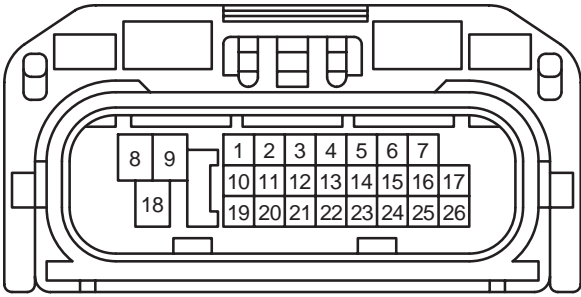

**C57**  
Gray

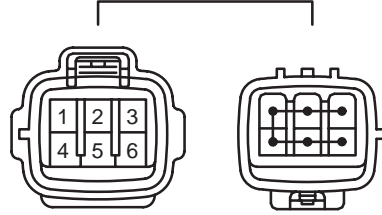

**D1**

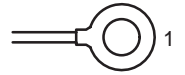

**E1**  
Black



**E2**  
Black



**E3**

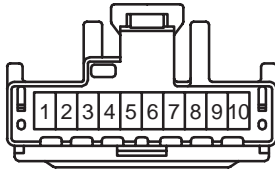

**E5**  
Black



**E6**

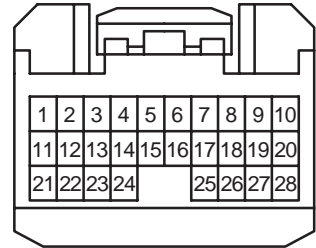

**E7**

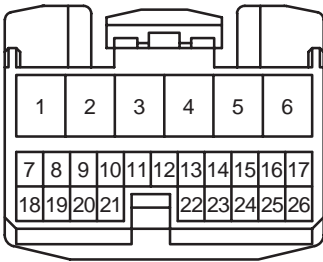

**E8**

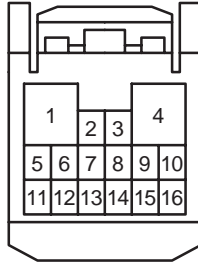

**E9**

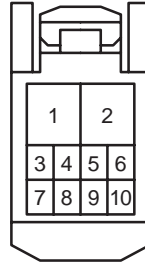

**E10**  
Black

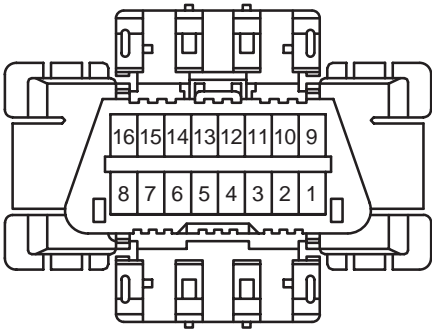

**E11**  
(Automatic A/C) Blue

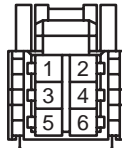

**E11**  
(Manual A/C) Black

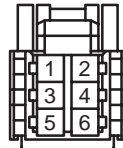

**E12**



**E13**  
Black



**E14**  
Black



**E15**

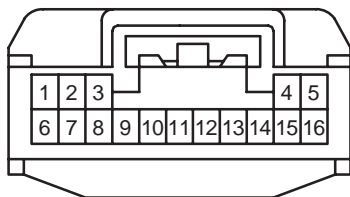

**E16**  
Yellow

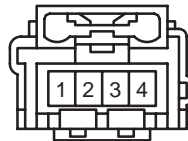

**E17**  
Black

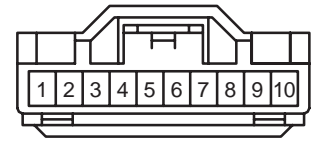

# K CONNECTOR LIST

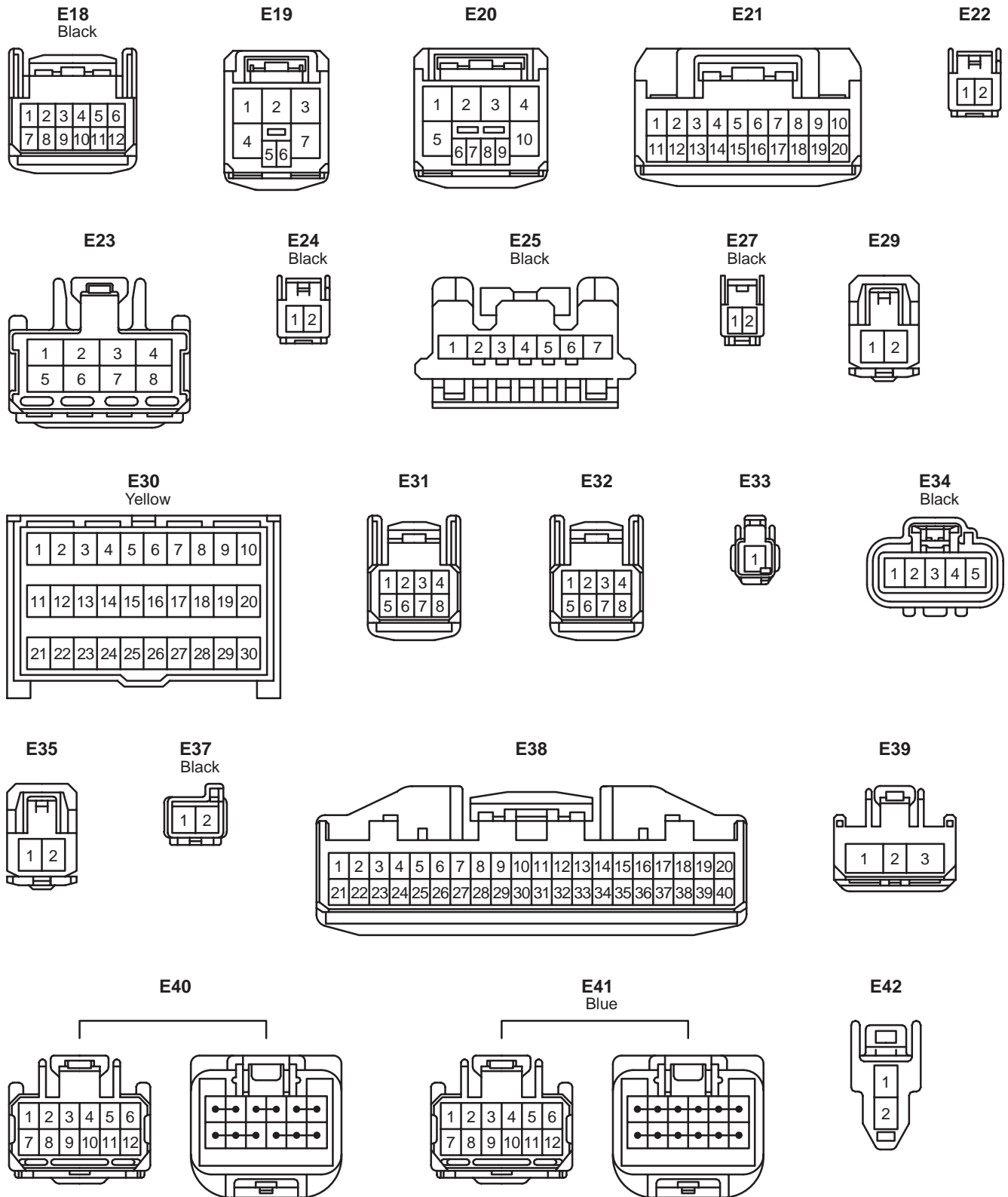

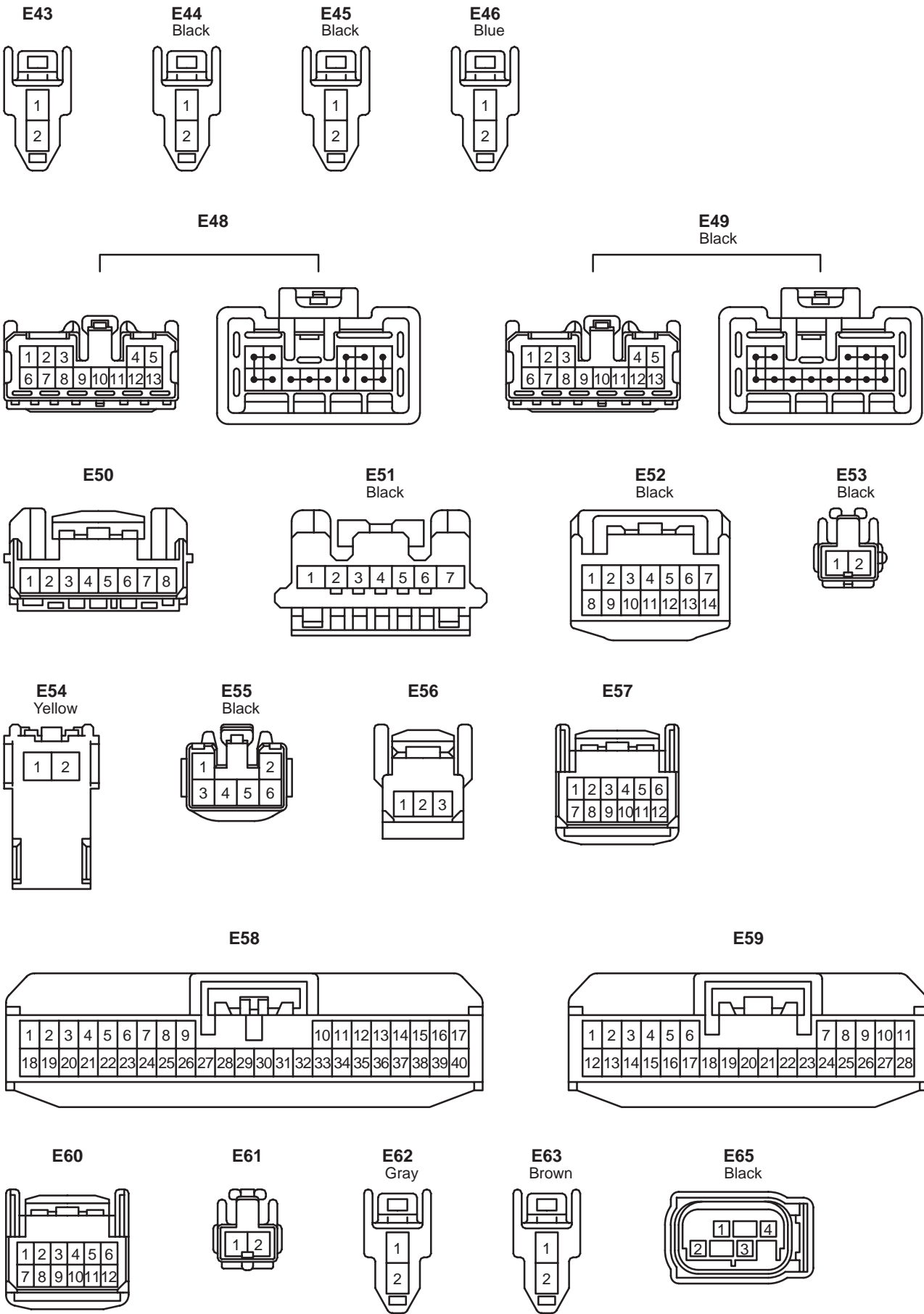

# K CONNECTOR LIST

F1

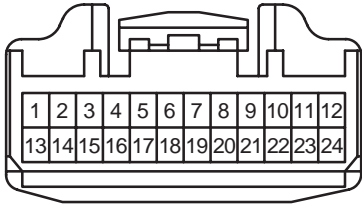

F2

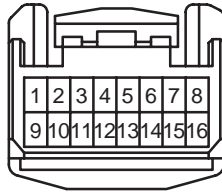

F3

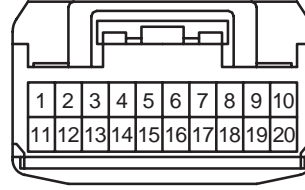

F4

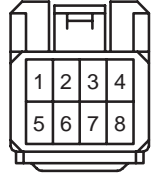

F5



F6

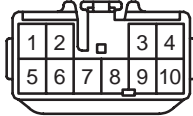

F7



F8

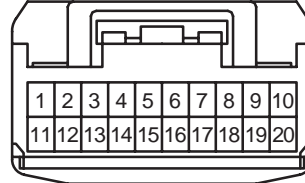

F9

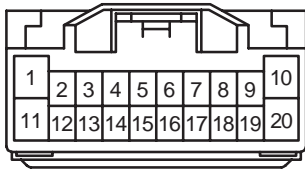

F10

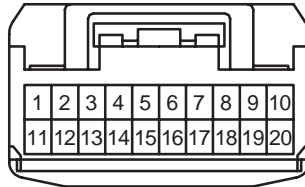

F11

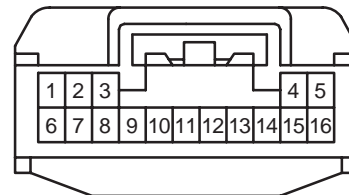

F12

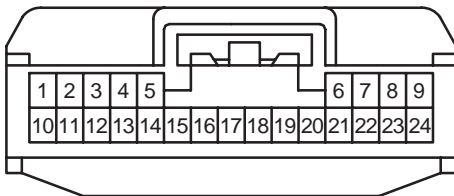

F13  
Gray

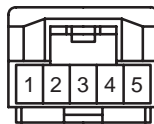

F14  
Blue

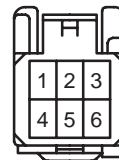

F15



F16  
Gray

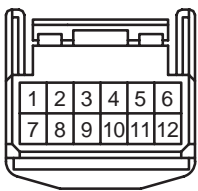

F17  
Gray

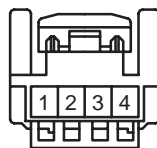

F18  
Blue

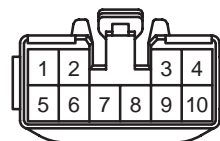

F19

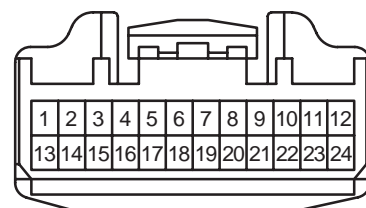

F20

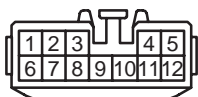

F21



F22

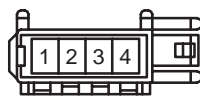

F23



F24

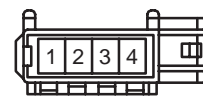

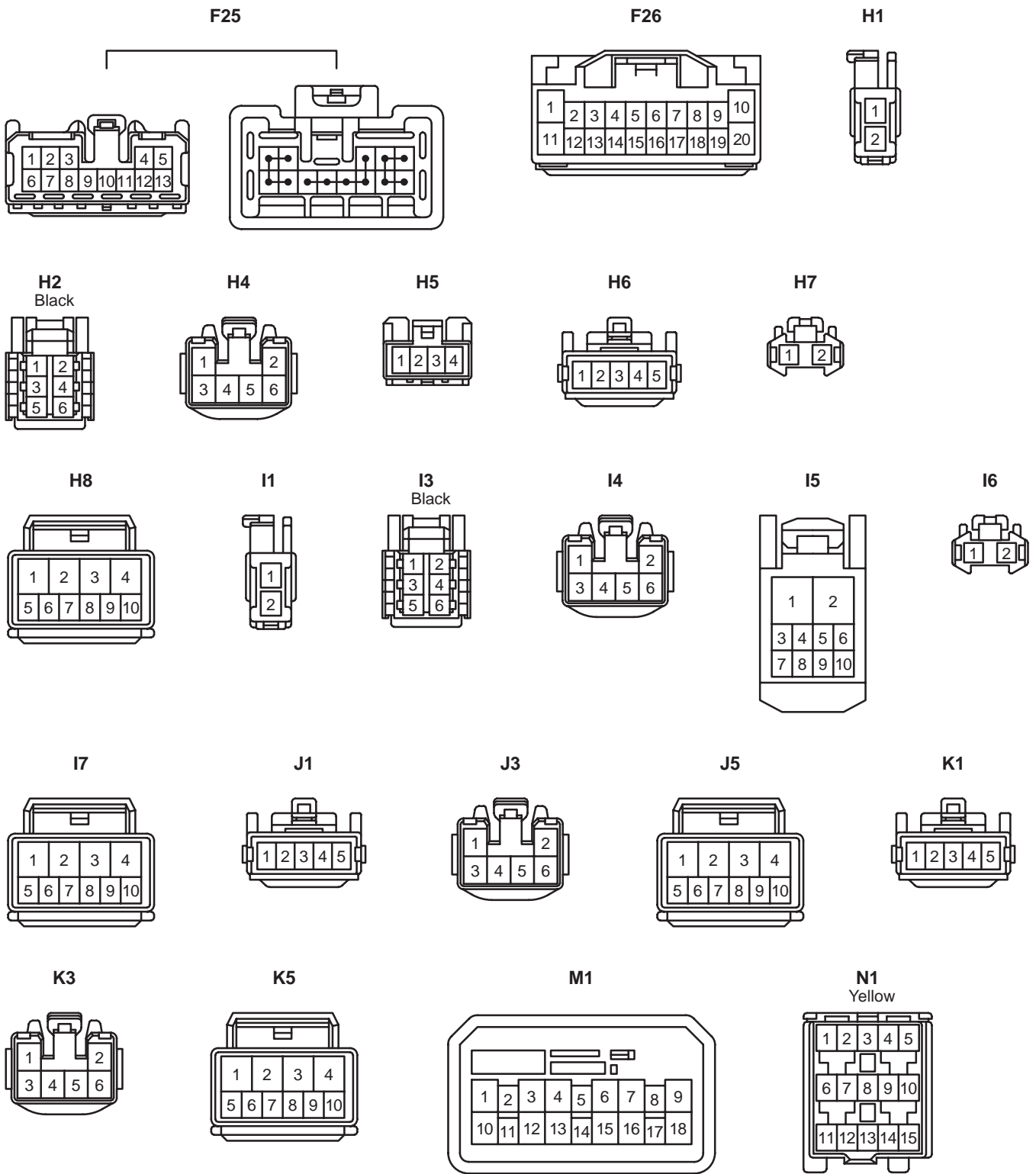



# K CONNECTOR LIST

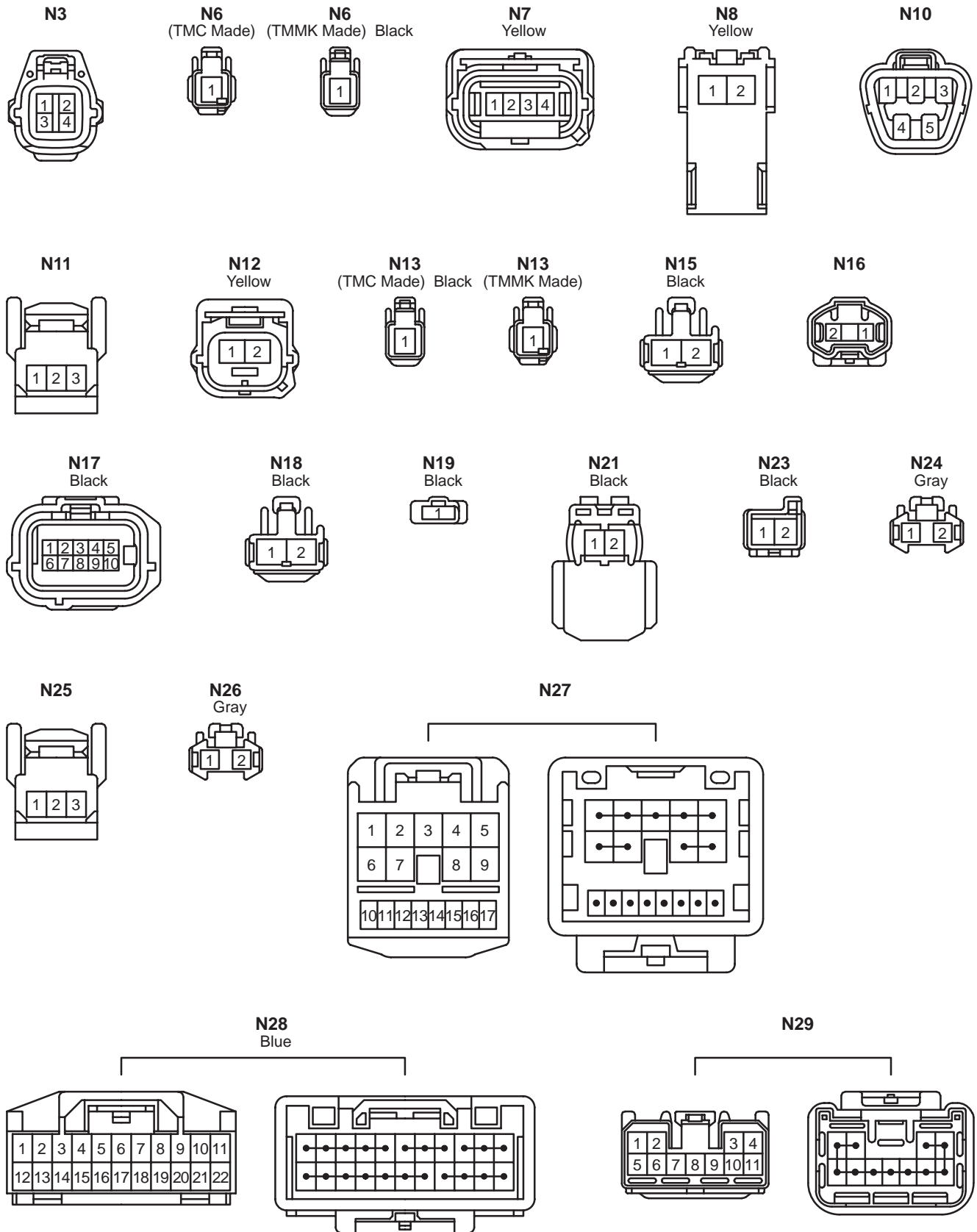

N34

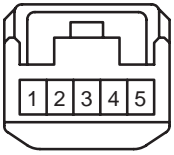

O1  
Yellow

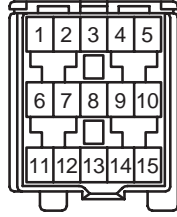

O3

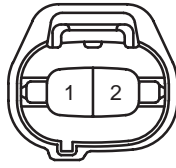

O4  
Black

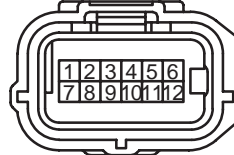

O6



O7  
Yellow



O8  
Yellow

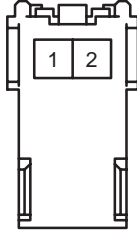

O9  
Yellow



O10  
Black



O12



O13



O14

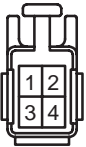

O15

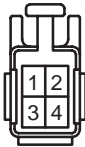

O16  
Black

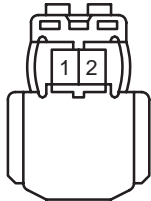

O17

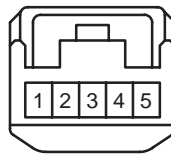

O18

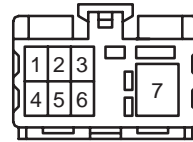

O19  
Gray



O20

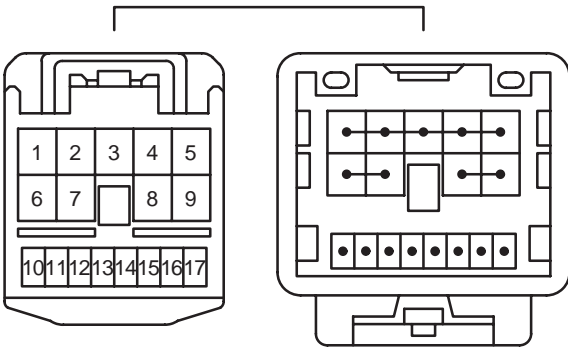

O21

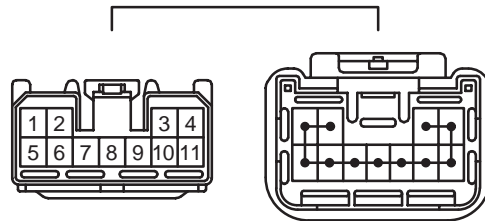

P1  
Black



Q1

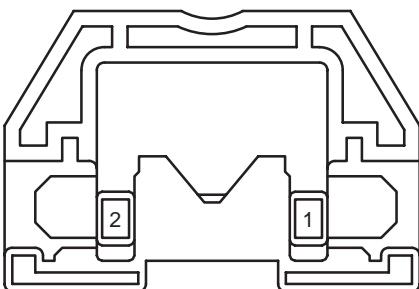

Q2

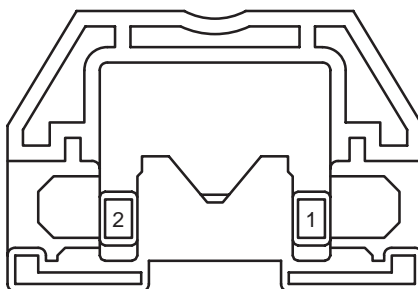

Q3

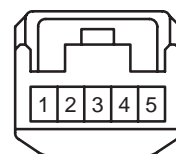

# K CONNECTOR LIST

**Q5**

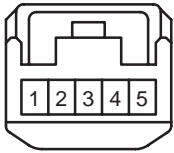

**Q6**

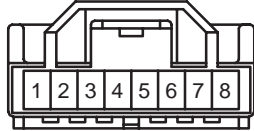

**Q7**  
Gray

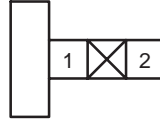

**Q8**  
Gray

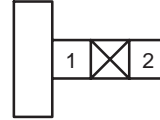

**Q9**  
Gray

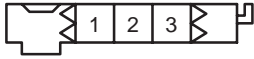

**Q10**  
Brown

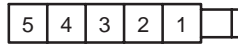

**Q11**  
Gray

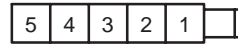

**Q12**  
Black

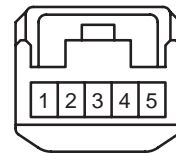

**Q13**

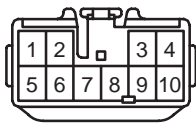

**S1**



**S2**

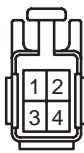

**S3**



**S4**



**S5**  
Black

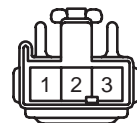

**S6**



**S8**

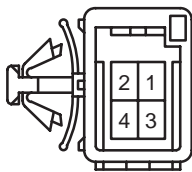

**S9**

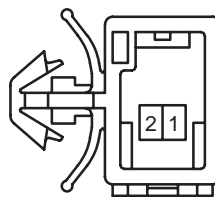

**S10**  
Gray



**S11**  
Black

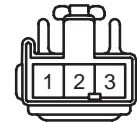

**S12**  
Black



**S13**  
Gray



**S14**



**S15**

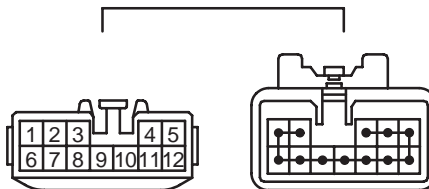

**S16**

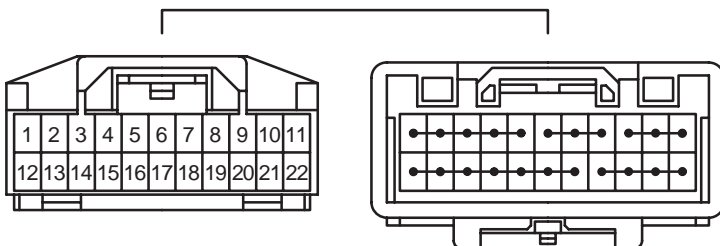

**T1**  
Black



**T3**  
Black



**T6**



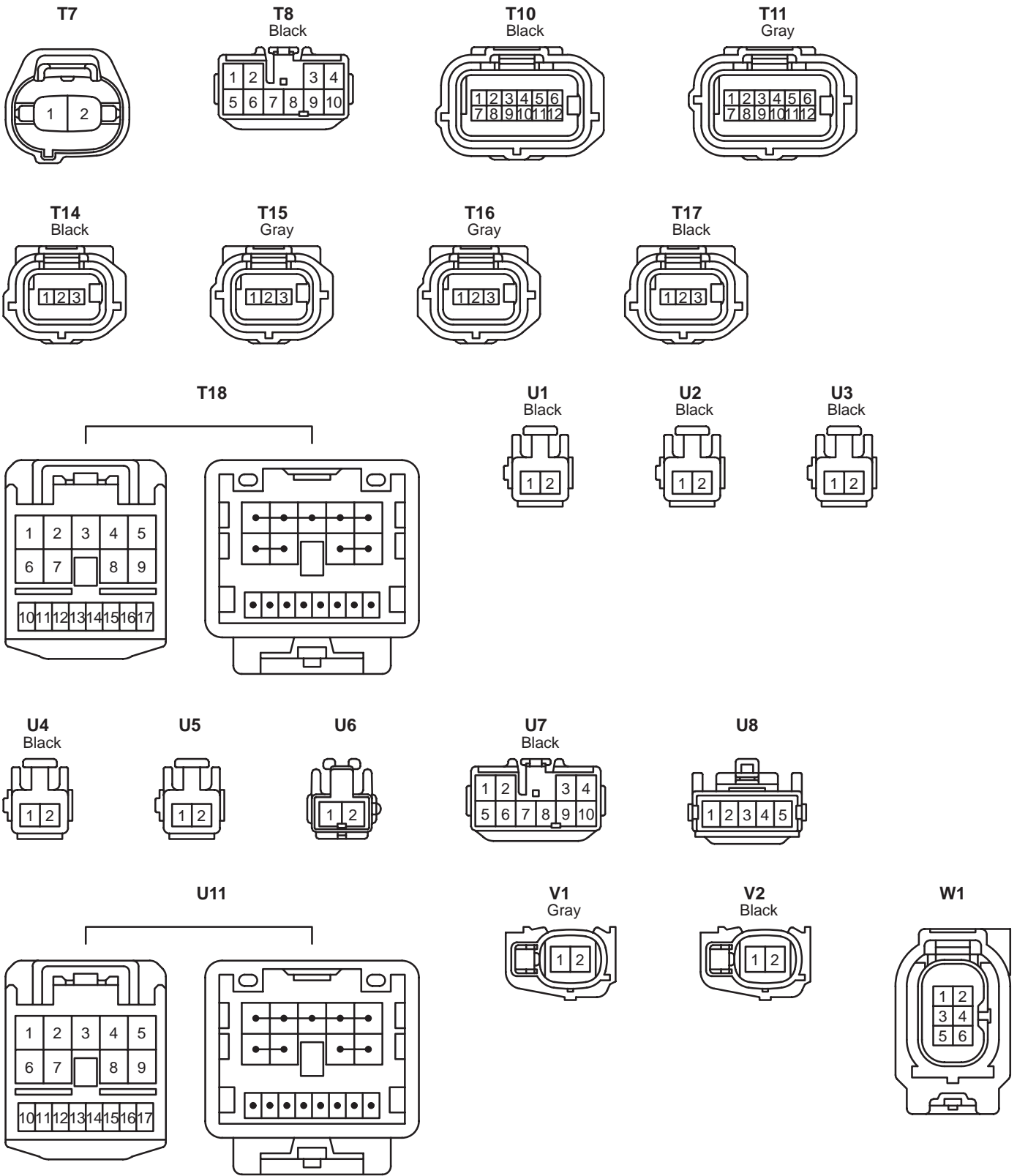

# K CONNECTOR LIST

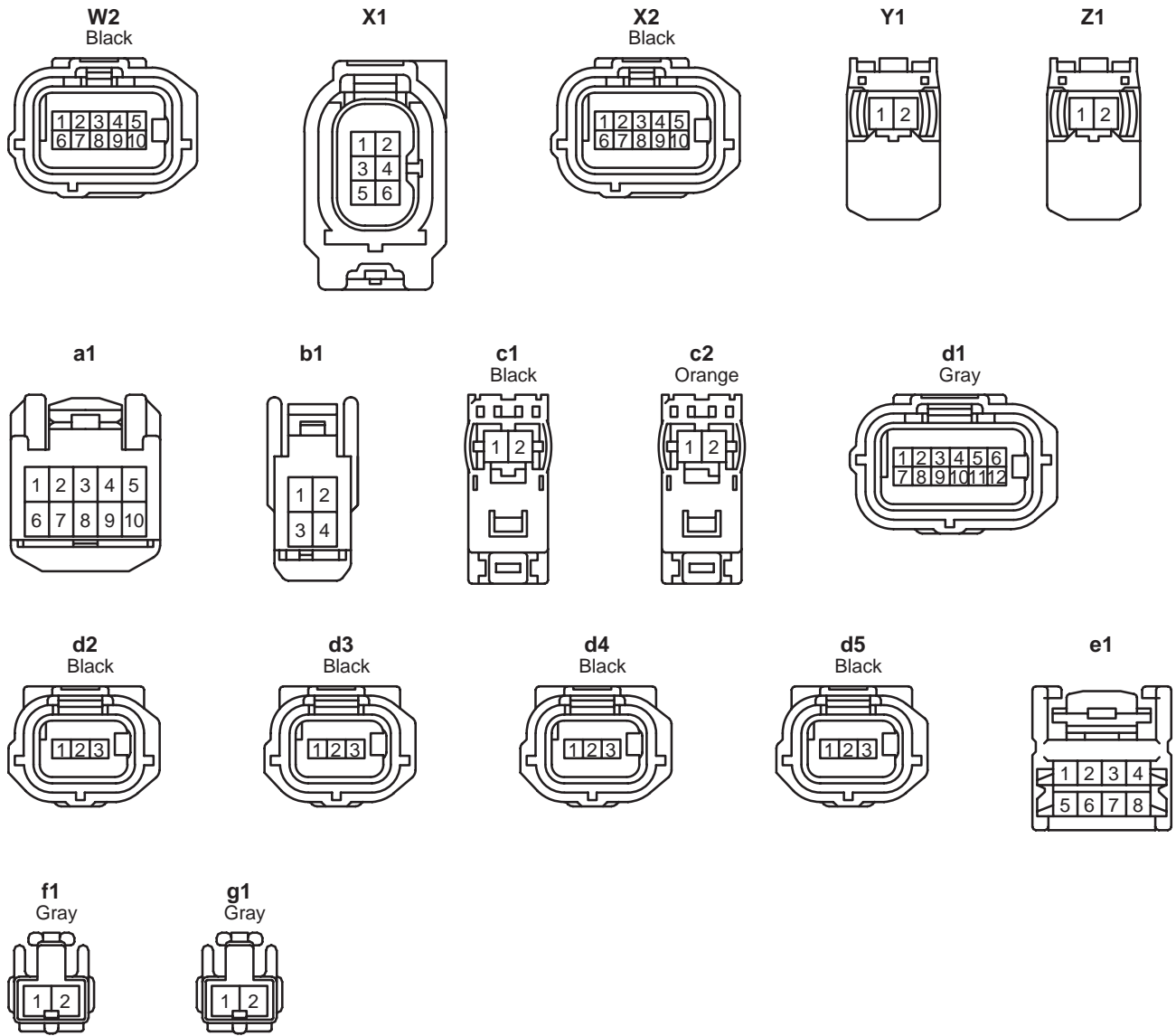



# K CONNECTOR LIST

**AB1** Gray

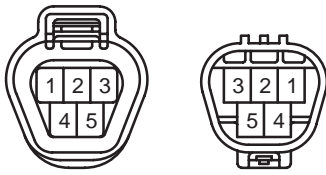

**AE2** Gray

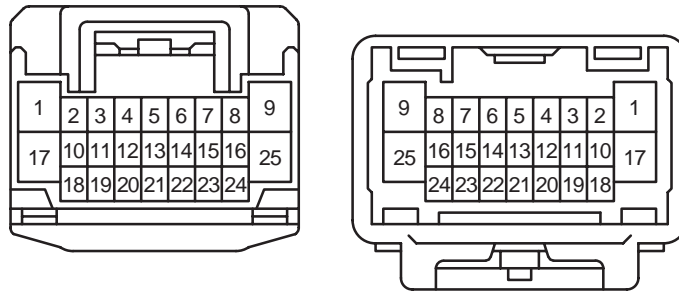

**AE3**

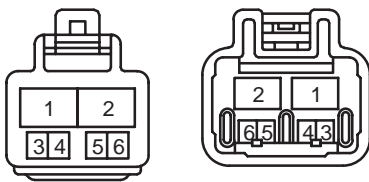

**AE4** Yellow

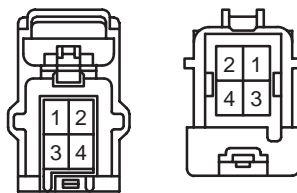

**AE5**

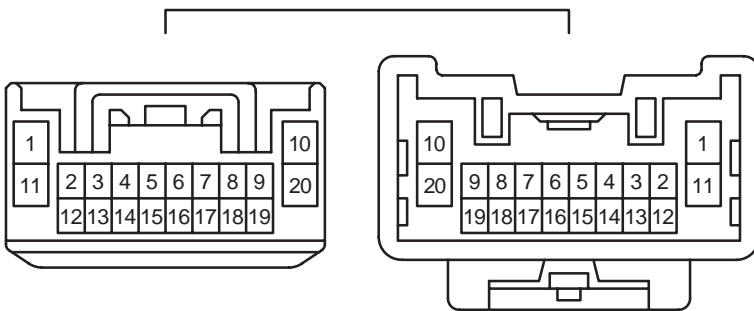

**AE6** Gray

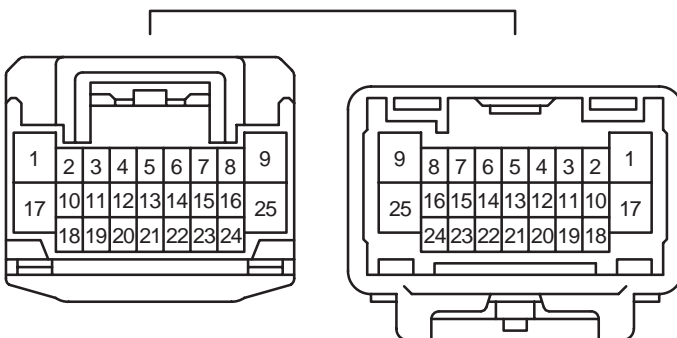

**AE7**

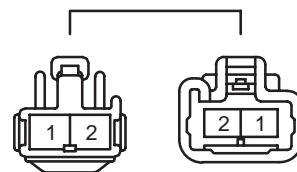

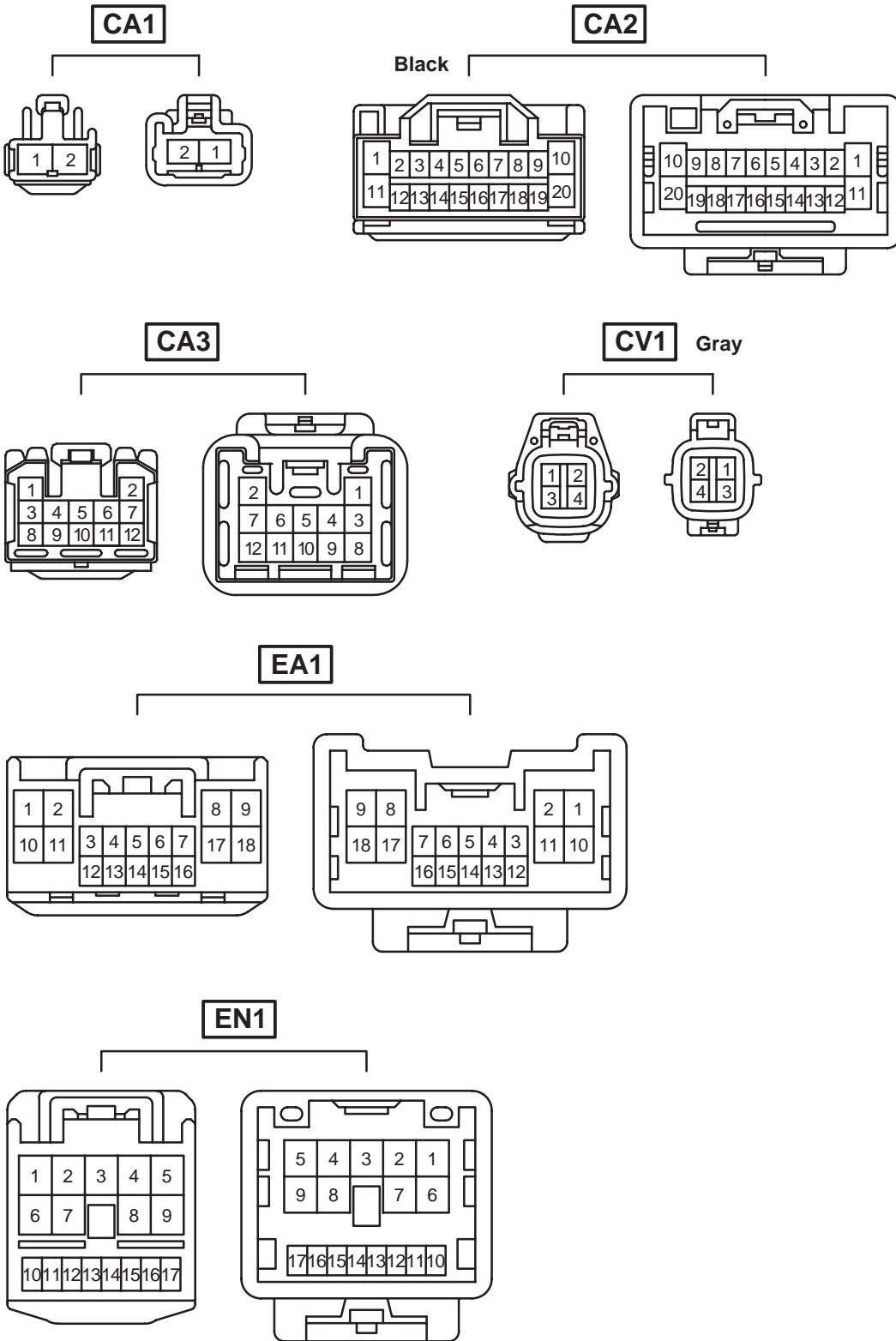



# K CONNECTOR LIST

**EN2** Blue

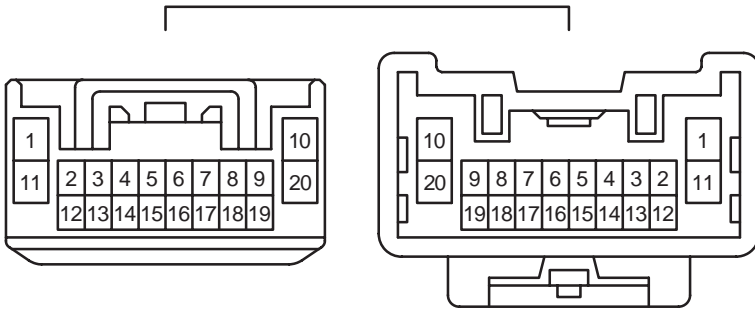

**EO1**

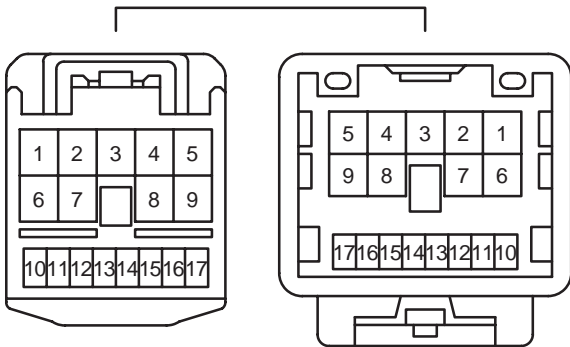

**EO2** Blue

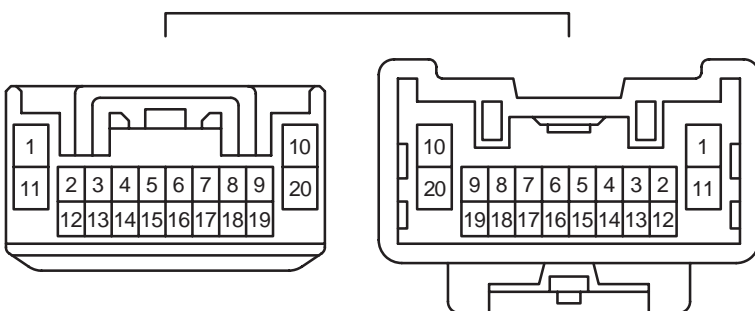

**EQ1**

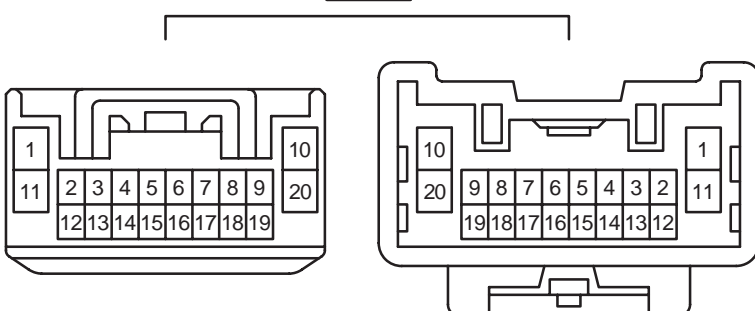

**Ec1** Yellow

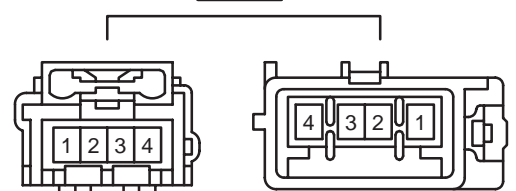

**FE2** Blue

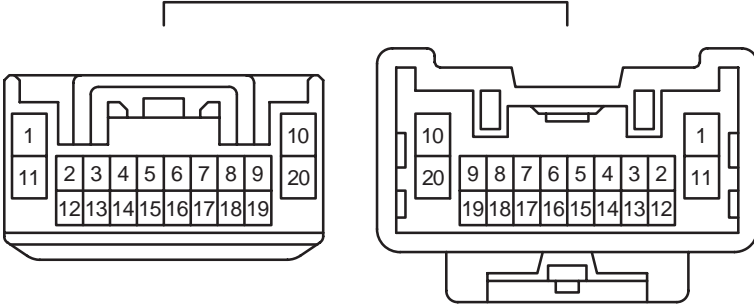

**FE3** Gray

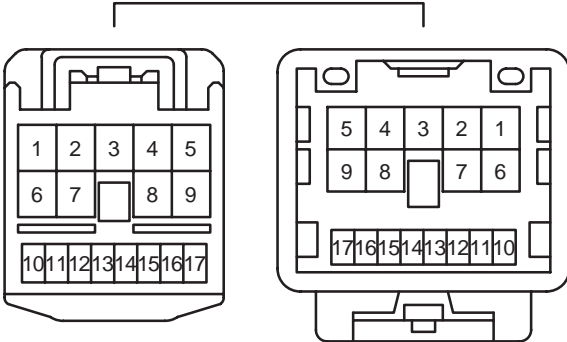

**HE1** Gray

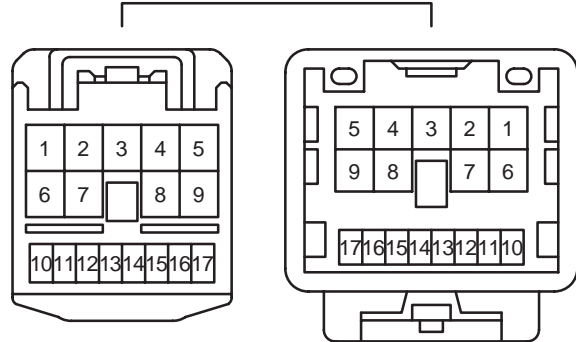

**HE2**

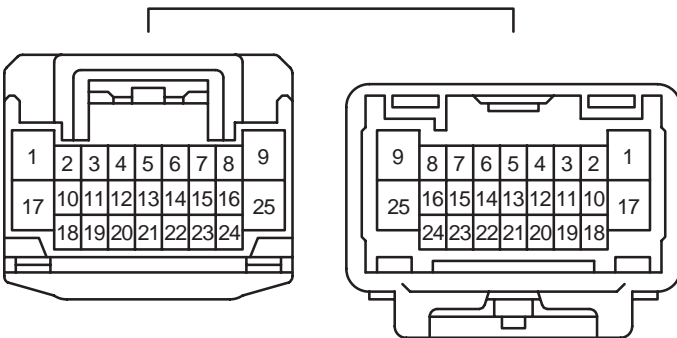

**HW1** Gray

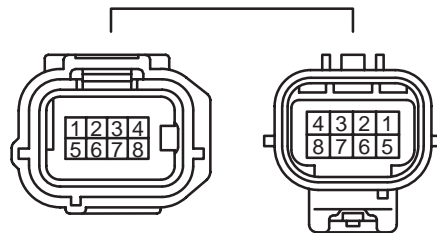

**IE1** Gray

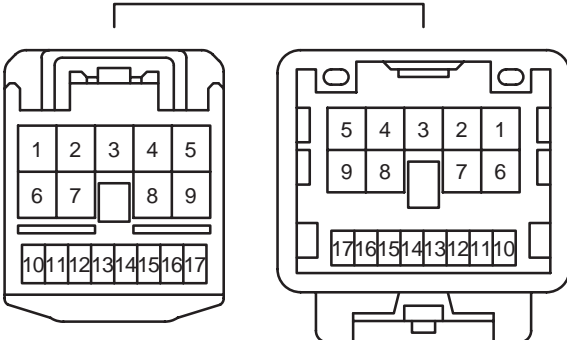

**IE2**

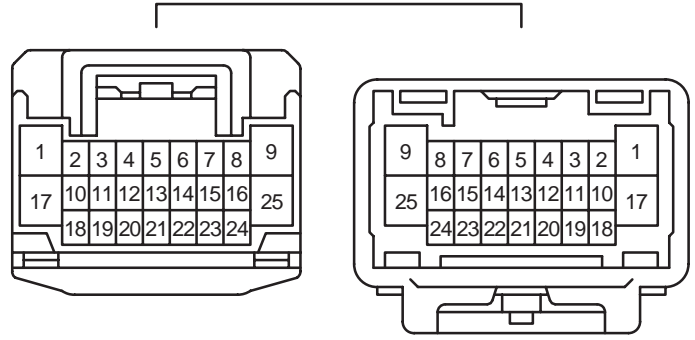

# K CONNECTOR LIST

## IM1

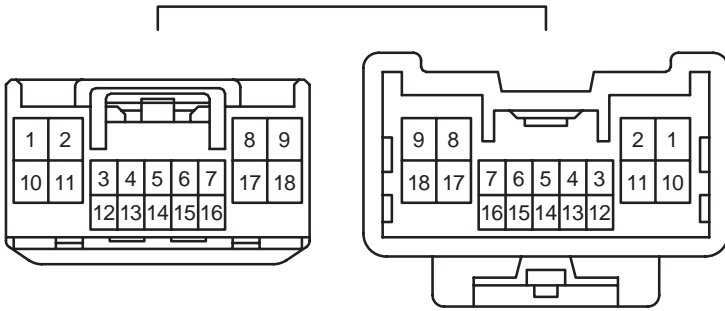

## IM2 Blue

## IX1 Gray

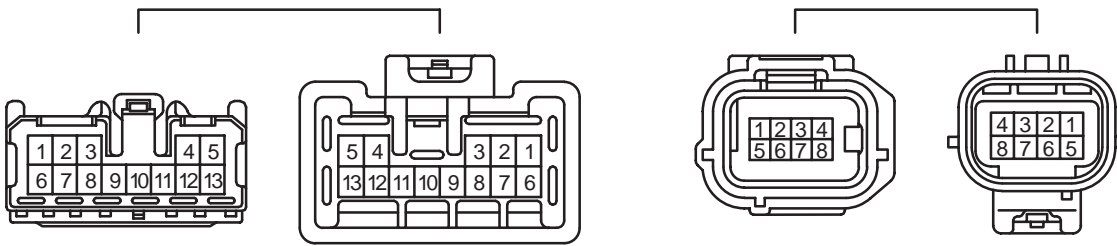

## JO1

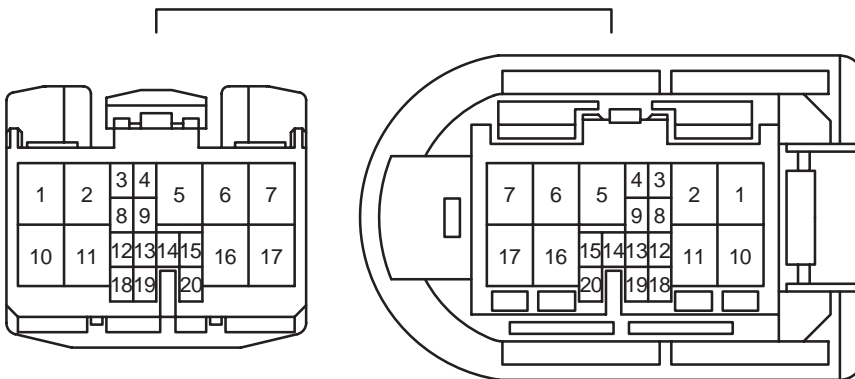

## KN1

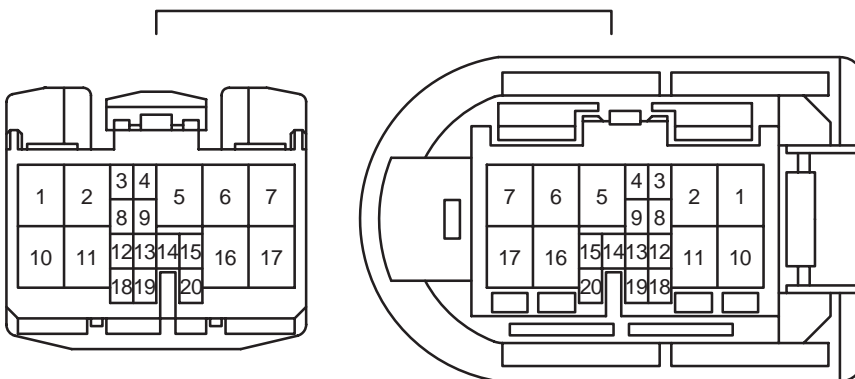

**NA1** Black

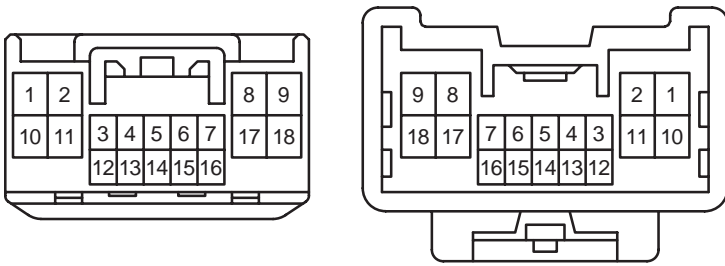

**NZ2**

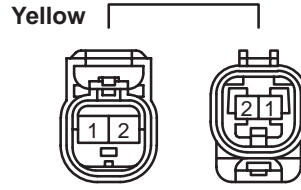

**OA1** Black

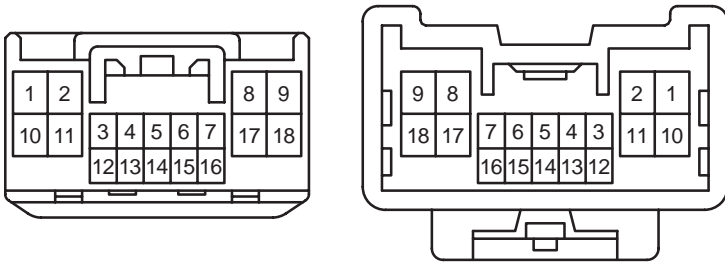

**OF1** Black

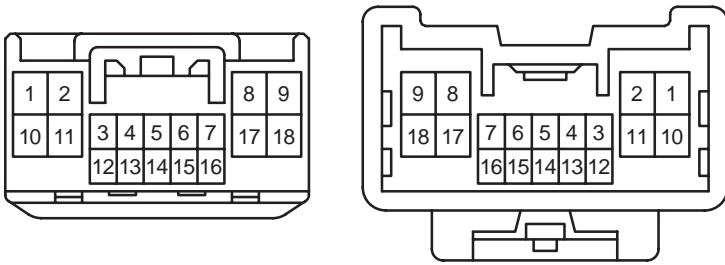

**OT1** Gray

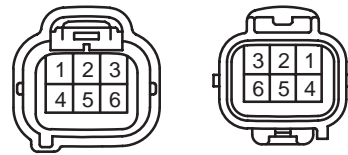

**OY2**

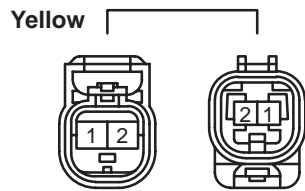

**SN1**

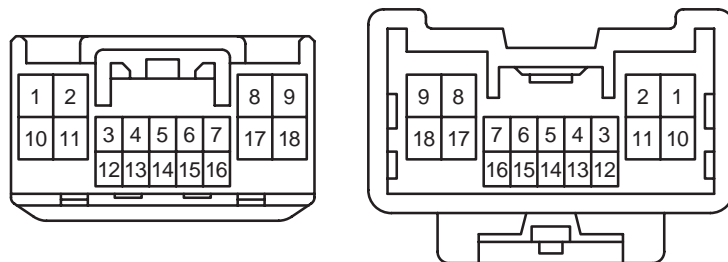

**f01**

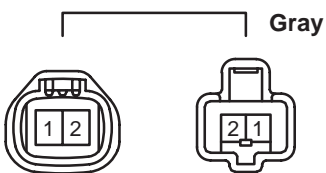

**gN1**

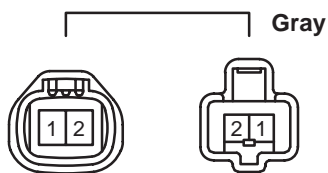

## L PART NUMBER OF CONNECTORS

| Code | Part Name                               | Part Number | Code | Part Name                                       | Part Number                              |
|------|---|-------------|------|---|--|
| A1   | Fog Lamp (Front LH)                     | 82824-60460 | B1   | Windshield Wiper Motor                          | 90980-11599                              |
| A2   | Ambient Temp. Sensor                    | 90980-11070 | C1   | Park/Neutral Position SW                        | 90980-12362                              |
| A3   | Horn (High)                             | 90980-10619 | C2   | Mass Air Flow Meter                             | 90980-12292                              |
| A4   | Horn (Low)                              |             | C3   | Starter   | 90980-11400                              |
| A5   | Engine Hood Courtesy SW                 | 90980-11002 | C4   | Engine Coolant Temp. Sensor                     | 90980-10735                              |
| A6   | A/C Condenser Fan Motor                 | 90980-10928 | C5   | Throttle Body Assembly                          | 90980-11858                              |
| A7   | Radiator Fan Motor                      |             | C6   | VSV (Purge)                                     | 90980-11156                              |
| A8   | Headlamp (LH High)                      | 90980-11659 | C7   | Fuel Injector (No.1)                            | 90980-11875                              |
| A13  | Airbag Sensor (Front LH)                | 90980-12490 | C8   | Fuel Injector (No.3)                            |  |
| A14  | Speed Sensor (Front LH)                 | 90980-11002 | C9   | Fuel Injector (No.2)                            |  |
| A16  | Brake Fluid Level Warning SW            | 90980-11207 | C10  | Fuel Injector (No.4)                            |  |
| A17  | Accelerator Position Sensor             | 90980-12303 | C11  | Ignition Coil (No.1)                            | 90980-11885                              |
| A18  | Parking Brake SW                        | 90980-10871 | C12  | Ignition Coil (No.3)                            |  |
| A19  | Stop Lamp SW                            | 90980-11118 | C13  | Ignition Coil (No.2)                            |  |
| A21  | Cruise Control Clutch SW                | 90980-10906 | C14  | Ignition Coil (No.4)                            |  |
| A22  | Clutch Start SW                         | 90980-10825 | C15  | Air Fuel Ratio Sensor (Bank 1 Sensor 1)         | 90980-11178                              |
| A23  | Security Horn                           | 90980-10619 | C16  | Noise Filter (Ignition RH)                      | 90980-10843                              |
| A24  | Engine Control Module                   | 90980-12461 | C17  | Power Steering Oil Pressure SW                  | 90980-11428                              |
| A25  | Skid Control ECU with Actuator          | 90980-WB001 | C18  | Generator                                       | 90980-11964                              |
| A26  | Skid Control ECU with Actuator          | 90980-12297 | C19  | Generator (2AZ-FE)                              | 90980-09213                              |
| A27  | A/C Pressure Sensor                     | 90980-10845 |      | Generator (2GR-FE)                              | 90980-09983                              |
| A28  | Airbag Sensor (Front RH)                | 90980-12490 | C20  | Crankshaft Position Sensor                      | 90980-10947                              |
| A29  | Headlamp (RH High)                      | 90980-11659 | C21  | A/C Compressor                                  | 90980-11156                              |
| A34  | Fog Lamp (Front RH)                     | 82824-60460 | C22  | Heated Oxygen Sensor (Bank 1 Sensor 2)          | 90980-11028                              |
| A35  | Speed Sensor (Front RH)                 | 90980-11002 | C23  | Engine Oil Pressure SW                          | 90980-11363                              |
| A37  | Windshield Washer Motor                 | 90980-11019 | C24  | Engine Control Module                           | 90980-12398                              |
| A40  | Junction Connector                      | 90980-11661 | C25  | Electronically Controlled Transmission Solenoid | 90980-12326                              |
| A41  | Junction Connector                      | 90980-12372 |      | C26   | Transmission Revolution Sensor (Turbine) |
| A42  | Junction Connector                      |             | C27  | Transmission Revolution Sensor (Counter Gear)   |  |
| A43  | Junction Connector                      | 90980-11194 | C28  | Back-Up Lamp SW                                 | 90980-11250                              |
| A45  | Headlamp (LH Low)                       | 82824-60460 | C29  | Starter   | 90980-11400                              |
| A46  | Turn Signal and Parking Lamp (Front LH) | 90980-11020 | C30  | Knock Control Sensor (Bank 1)                   | 90980-11875                              |
| A47  | Side Marker Lamp (Front LH)             | 90980-11162 | C31  | Camshaft Position Sensor                        | 90980-10947                              |
| A48  | Wireless Door Lock Buzzer               | 90980-11142 | C32  | Camshaft Timing Oil Control Valve               | 90980-11162                              |
| A49  | Headlamp (RH Low)                       | 82824-60460 | C33  | Intake Air Control Valve                        | 90980-11599                              |
| A50  | Turn Signal and Parking Lamp (Front RH) | 90980-11020 | C34  | VSV (ACM)                                       | 90980-11156                              |
| A51  | Side Marker Lamp (Front RH)             | 90980-11162 | C35  | Air Fuel Ratio Sensor (Bank 2 Sensor 1)         | 90980-11178                              |
| A52  | Washer Level Warning SW                 | 90980-11068 | C36  | Fuel Injector (No.5)                            | 90980-11875                              |
| A53  | VSV (Air Intake Control)                | 90980-11156 |      | C37   |  |
| A54  | Cooling Fan ECU                         | 90980-12058 | C38  | Ignition Coil (No.5)                            | 90980-11885                              |
| A55  | Engine Control Module                   | 90980-12462 |      | C39   |  |
| A56  | Short Connector                         | 90980-12204 | C40  | VVT Sensor (Bank 1 Exhaust Side)                | 90980-12353                              |
| A57  | Short Connector                         | 90980-12012 |      | C41   |  |
| A58  | Junction Connector                      | 90980-11661 |      |   |  |
| A59  | Windshield Wiper Motor                  | 90980-11599 |      |   |  |
| A60  | Skid Control ECU with Actuator          | 90980-WA008 |      |   |  |

Note: Not all of the above part numbers of the connector are established for the supply.

| Code | Part Name   | Part Number | Code | Part Name                           | Part Number |
|------|---|-------------|------|-------------------------------------|-------------|
| C42  | Camshaft Timing Oil Control Valve (RH Exhaust Side) | 90980-11162 | E31  | Transmission Control SW             | 90980-12551 |
| C43  | Camshaft Timing Oil Control Valve (RH Intake Side)  |             | E32  | Shift Lock Control ECU              |             |
| C44  | VVT Sensor (Bank 2 Exhaust Side)                    | 90980-12353 | E33  | Parking Brake SW                    | 90980-10871 |
| C45  | VVT Sensor (Bank 2 Intake Side)                     |             | E34  | Yaw Rate Sensor                     | 90980-11904 |
| C46  | Camshaft Timing Oil Control Valve (LH Exhaust Side) | 90980-11162 | E35  | Power Outlet Socket (Rear)          | 90980-12498 |
| C47  | Camshaft Timing Oil Control Valve (LH Intake Side)  |             | E37  | Diode (Door Courtesy Front RH)      | 90980-10962 |
| C48  | VSV (ACIS)  |             | E38  | A/C Amplifier                       | 90980-12557 |
| C49  | Noise Filter (Ignition LH)                          |             | E39  | Blower Motor                        | 90980-11667 |
| C50  | Crankshaft Position Sensor                          | 90980-10843 | E40  | Junction Connector                  | 90980-11661 |
| C51  | Heated Oxygen Sensor (Bank 2 Sensor 2)              | 90980-12611 | E41  | Junction Connector                  |             |
| C52  | Heated Oxygen Sensor (Bank 1 Sensor 2)              | 90980-11028 | E42  | Junction Connector                  | 90980-12355 |
| C53  | A/C Compressor                                      | 90980-10869 | E43  | Junction Connector                  |             |
| C55  | Engine Control Module                               | 90980-11016 | E44  | Junction Connector                  |             |
| C56  | Transmission Control ECU                            | 90980-12396 | E45  | Junction Connector                  |             |
| C57  | Junction Connector                                  | 90980-12649 | E46  | Junction Connector                  |             |
| D1   | Starter   | 90980-11194 | E48  | Junction Connector                  | 90980-11542 |
| E1   | Diode (Door Courtesy Rear LH)                       | 90980-10962 | E49  | Junction Connector                  |             |
| E2   | Diode (Door Courtesy Rear RH)                       |             | E50  | ID Code Box                         | 90980-12558 |
| E3   | Outer Mirror SW                                     | 90980-11657 | E51  | Steering Lock ECU                   | 90980-12092 |
| E5   | Diode (Door Courtesy Front LH)                      | 90980-10962 | E52  | Power SW                            | 90980-12370 |
| E6   | Main Body ECU                                       | 90980-12330 | E53  | Tire Pressure Warning SW (Reset)    | 90980-10906 |
| E7   | Main Body ECU                                       | 90980-12561 | E54  | Airbag Squib (Knee Airbag)          | 90980-12253 |
| E8   | Main Body ECU                                       | 90980-12329 | E55  | Seat Heater SW                      | 90980-10797 |
| E9   | Main Body ECU                                       | 90980-12328 | E56  | Electrical Key Oscillator (Console) | 90980-12296 |
| E10  | Data Link Connector 3                               | 90980-11665 | E57  | Shift Lock Control ECU              | 90980-12552 |
| E11  | Automatic Light Control Sensor                      | 90980-12056 | E58  | Certification ECU                   | 90980-12567 |
| E12  | Ion Generator                                       | 90980-11909 | E59  | Certification ECU                   | 90980-12566 |
| E13  | VSC Warning Buzzer                                  | 90980-10906 | E60  | Tire Pressure Warning ECU           | 90980-12552 |
| E14  | Turn Signal Flasher                                 | 90980-10799 | E61  | Option Connector (Bus Buffer)       | 90980-10860 |
| E15  | Transponder Key ECU                                 | 90980-12423 | E62  | Junction Connector                  | 90980-12355 |
| E16  | Airbag Squib (Steering Wheel Pad)                   | 90980-12160 | E63  | Junction Connector                  |             |
| E17  | Steering Sensor                                     | 90980-12162 | E65  | Yaw Rate Sensor                     | 90080-98249 |
| E18  | Spiral Cable  | 90980-12552 | F1   | Combination Meter                   | 90980-12554 |
| E19  | Windshield Wiper SW Assembly                        | 90980-12358 | F2   | Combination Meter                   | 90980-12553 |
| E20  | Windshield Wiper SW Assembly                        | 90980-12359 | F3   | Clock                               | 90980-12460 |
| E21  | Headlamp Dimmer SW Assembly                         | 90980-12460 | F4   | Hazard Warning Signal SW            | 90980-12113 |
| E22  | Unlock Warning SW                                   | 90980-12063 | F5   | Glove Box Lamp                      | 90980-11098 |
| E23  | Ignition SW   | 90980-11615 | F6   | Radio Receiver Assembly             | 90980-10997 |
| E24  | Key Interlock Solenoid                              | 90980-12063 | F7   | Radio Receiver Assembly             | 90980-10996 |
| E25  | Transponder Key Amplifier                           | 90980-12092 | F8   | Radio Receiver Assembly             | 90980-12460 |
| E27  | A/C Room Temp. Sensor                               | 90980-11918 | F9   | Navigation Receiver Assembly        | 90980-12038 |
| E29  | Power Outlet Socket (Front)                         | 90980-12498 | F10  | Navigation Receiver Assembly        | 90980-12460 |
| E30  | Airbag Sensor Assembly Center                       | 90980-12391 | F11  | Radio Receiver Assembly             | 90980-12423 |
|      |   |             | F12  | Navigation Receiver Assembly        | 90980-12404 |
|      |   |             | F13  | Navigation Receiver Assembly        | 90980-11909 |

## L PART NUMBER OF CONNECTORS

| Code | Part Name   | Part Number | Code | Part Name                                       | Part Number |
|------|---|-------------|------|---|-------------|
| F14  | Navigation Receiver Assembly                          | 90980-12209 | N12  | Side Airbag Sensor (Rear LH)                    | 90980-11856 |
| F15  | Antenna Amplifier                                     | 90980-10871 | N13  | Door Courtesy SW (Rear LH) (TMC Made)           | 82824-33280 |
| F16  | A/C Control Assembly                                  | 90980-12559 |      | Door Courtesy SW (Rear LH) (TMMK Made)          | 90980-10871 |
| F17  | Stereo Jack Adapter                                   | 82824-21030 | N15  | Noise Filter (Dome and Stop)                    | 90980-10916 |
| F18  | Stereo Component Amplifier                            | 90980-10801 | N16  | Center Stop Lamp                                | 90980-11159 |
| F19  | Stereo Component Amplifier                            | 90980-12554 | N17  | Canister Pump Module                            | 90980-12380 |
| F20  | Stereo Component Amplifier                            | 90980-10803 | N18  | Noise Filter (Rear Window Defogger)             | 90980-10916 |
| F21  | Tweeter (Front LH)                                    | 90980-10860 | N19  | Rear Window Defogger                            | 90980-10913 |
| F22  | Tweeter (Front LH)                                    | 90980-12304 | N21  | Curtain Shield Airbag Squib (LH)                | 90980-12575 |
| F23  | Tweeter (Front RH)                                    | 90980-10860 | N23  | Diode (Luggage Compartment Lamp)                | 90980-10962 |
| F24  | Tweeter (Front RH)                                    | 90980-12304 | N24  | Luggage Compartment Lamp                        | 90980-11148 |
| F25  | Junction Connector                                    | 90980-11542 | N25  | Electrical Key Oscillator (Inside Luggage Room) | 90980-12296 |
| F26  | Radio Receiver Assembly                               | 90980-12038 | N26  | Luggage Compartment Lamp                        | 90980-11148 |
| H1   | Speaker (Front Door RH)                               | 90980-10935 | N27  | Junction Connector                              | 90980-12374 |
| H2   | Outer Rear View Mirror (RH)                           | 90980-12056 | N28  | Junction Connector                              | 90980-11915 |
| H4   | Power Window Regulator Motor (Front Passenger's Side) | 90980-10797 | N29  | Junction Connector                              | 90980-11539 |
| H5   | Door Lock Control SW                                  | 90980-11950 | N34  | Tire Pressure Warning Antenna and Receiver      | 90980-12366 |
| H6   | Power Window SW (Front Passenger's Side)              | 90980-10789 | O1   | Airbag Sensor Assembly Center                   | 90980-12450 |
| H7   | Courtesy Lamp (Front Door RH)                         | 90980-11148 | O3   | Front Seat Inner Belt (Front Passenger's Side)  | 90980-11156 |
| H8   | Door Lock Assembly (Front Passenger's Side)           | 90980-12226 | O4   | Occupant Classification ECU                     | 90980-12356 |
| I1   | Speaker (Front Door LH)                               | 90980-10935 | O6   | Door Courtesy SW (Front Passenger's Side)       | 90980-10871 |
| I3   | Outer Rear View Mirror (LH)                           | 90980-12056 | O7   | Side Airbag Sensor (Front RH)                   | 90980-12225 |
| I4   | Power Window Regulator Motor (Front LH)               | 90980-10797 | O8   | Pretensioner (RH)                               | 90980-12253 |
| I5   | Power Window Regulator Motor (Front LH)               | 90980-12328 | O9   | Side Airbag Sensor (Rear RH)                    | 90980-11856 |
| I6   | Courtesy Lamp (Front Door LH)                         | 90980-11148 | O10  | Door Courtesy SW (Rear RH)                      | 82824-33280 |
| I7   | Door Lock Assembly (Driver's Side)                    | 90980-12226 | O12  | Speaker (Rear LH)                               | 90980-11299 |
| J1   | Power Window SW (Rear RH)                             | 90980-10789 | O13  | Speaker (Rear RH)                               |             |
| J3   | Power Window Regulator Motor (Rear RH)                | 90980-10797 | O14  | Speaker (Rear LH)                               | 90980-10795 |
| J5   | Door Lock Assembly (Rear RH)                          | 90980-12226 | O15  | Speaker (Rear RH)                               |             |
| K1   | Power Window SW (Rear LH)                             | 90980-10789 | O16  | Curtain Shield Airbag Squib (RH)                | 90980-12575 |
| K3   | Power Window Regulator Motor (Rear LH)                | 90980-10797 | O17  | Door Control Receiver                           | 90980-12366 |
| K5   | Door Lock Assembly (Rear LH)                          | 90980-12226 | O18  | Door Control Receiver                           | 90980-50011 |
| M1   | Power Window Master SW                                | 90980-12122 | O19  | Electrical Key Antenna                          | 90980-12043 |
| N1   | Airbag Sensor Assembly Center                         | 90980-12449 | O20  | Junction Connector                              | 90980-12374 |
| N3   | Front Seat Inner Belt (Driver's Side)                 | 90980-10942 | O21  | Junction Connector                              | 90980-11539 |
| N6   | Door Courtesy SW (Driver's Side) (TMC Made)           | 90980-10871 | P1   | Rear Window Defogger                            | 90980-10914 |
|      | Door Courtesy SW (Driver's Side) (TMMK Made)          | 82824-33280 | Q1   | Vanity Lamp SW (LH)                             | 90980-12322 |
| N7   | Side Airbag Sensor (Front LH)                         | 90980-12225 | Q2   | Vanity Lamp SW (RH)                             |             |
| N8   | Pretensioner (LH)                                     | 90980-12253 | Q3   | Inner Rear View Mirror                          | 90980-12366 |
| N10  | Fuel Suction Pump and Gage Assembly                   | 90980-11077 | Q5   | Microphone (Navigation)                         |             |
| N11  | Electrical Key Oscillator (Rear Seat)                 | 90980-12296 | Q6   | Overhead J/B                                    | 90980-11989 |

Note: Not all of the above part numbers of the connector are established for the supply.

| Code | Part Name   | Part Number | Code | Part Name   | Part Number |
|------|---|-------------|------|---|-------------|
| Q7   | Vanity Lamp (LH)  | -           | U1   | Power Seat Motor (Driver's Seat Slide Control)              | 90980-10825 |
| Q8   | Vanity Lamp (RH)  |             | U2   | Power Seat Motor (Driver's Seat Front Vertical Control)     |             |
| Q9   | Room Lamp (Center)  |             | U3   | Power Seat Motor (Driver's Seat Reclining Control)          |             |
| Q10  | Map Lamp (RH)   |             | U4   | Power Seat Motor (Driver's Seat Lifter Control)             |             |
| Q11  | Map Lamp (LH)   |             | U5   | Power Seat Motor (Driver's Seat Lumbar Support Control)     |             |
| Q12  | Microphone (Navigation)                                     | 90980-12366 | U6   | Seat Heater (LH)  | 90980-10906 |
| Q13  | Sliding Roof Control ECU and Motor                          | 90980-10997 | U7   | Power Seat SW (Driver's Seat)                               | 90980-10997 |
| S1   | License Plate Lamp (RH)                                     | 90980-11148 | U8   | Power Seat SW (Driver's Seat Lumbar Support Control)        | 90980-10789 |
| S2   | Rear Combination Lamp (RH)                                  | 90980-10795 | U11  | Junction Connector  | 90980-12374 |
| S3   | Rear Combination Lamp (LH)                                  |             | V1   | Knock Control Sensor (Bank 2)                               | 90980-11875 |
| S4   | License Plate Lamp (LH)                                     | 90980-11148 | V2   | Knock Control Sensor (Bank 1)                               |             |
| S5   | Door Lock Assembly (Luggage)                                | 90980-10908 | W1   | Door Outside Handle (Front RH)                              | 90980-12382 |
| S6   | Luggage Compartment Door Lock Cylinder                      | 90980-11060 | W2   | Electrical Key Oscillator (Front Door RH)                   | 90980-12380 |
| S8   | Luggage Compartment Door Lock Cylinder                      | 90980-12212 | X1   | Door Outside Handle (Front LH)                              | 90980-12382 |
| S9   | Luggage Electrical Key SW                                   | 90980-11967 | X2   | Electrical Key Oscillator (Front Door LH)                   | 90980-12380 |
| S10  | Turn Signal Lamp (Rear LH)                                  | 90980-10906 | Y1   | Side Airbag Squib (RH)                                      | 90980-12452 |
| S11  | Rear Combination Lamp (LH)                                  | 90980-10908 | Z1   | Side Airbag Squib (LH)                                      |             |
| S12  | Rear Combination Lamp (RH)                                  |             | S14  | Electrical Key Oscillator (Outside Luggage Room)            | 90980-12381 |
| S13  | Turn Signal Lamp (Rear RH)                                  | 90980-10906 | S15  | Junction Connector  | 90980-10803 |
| S14  | Electrical Key Oscillator (Outside Luggage Room)            | 90980-12381 | S16  | Junction Connector  | 90980-11915 |
| S15  | Junction Connector  | 90980-10803 | T1   | Power Seat Motor (Front Passenger's Seat Slide Control)     | 90980-10825 |
| S16  | Junction Connector  | 90980-11915 | T3   | Power Seat Motor (Front Passenger's Seat Reclining Control) |             |
| T1   | Power Seat Motor (Front Passenger's Seat Slide Control)     | 90980-10825 | T6   | Seat Heater (RH)  | 90980-10906 |
| T3   | Power Seat Motor (Front Passenger's Seat Reclining Control) |             | T7   | Front Seat Inner Belt (Front Passenger's Side)              | 90980-11156 |
| T6   | Seat Heater (RH)  | 90980-10906 | T8   | Power Seat SW (Front Passenger's Seat)                      | 90980-10997 |
| T7   | Front Seat Inner Belt (Front Passenger's Side)              | 90980-11156 | T10  | Occupant Classification ECU                                 | 90980-12356 |
| T8   | Power Seat SW (Front Passenger's Seat)                      | 90980-10997 | T11  | Occupant Classification ECU                                 | 90980-12357 |
| T10  | Occupant Classification ECU                                 | 90980-12356 | T14  | Occupant Classification Sensor (Front LH)                   | 90980-12353 |
| T11  | Occupant Classification ECU                                 | 90980-12357 | T15  | Occupant Classification Sensor (Rear LH)                    | 90980-12354 |
| T14  | Occupant Classification Sensor (Front LH)                   | 90980-12353 | T16  | Occupant Classification Sensor (Front RH)                   |             |
| T15  | Occupant Classification Sensor (Rear LH)                    | 90980-12354 | T17  | Occupant Classification Sensor (Rear RH)                    | 90980-12353 |
| T16  | Occupant Classification Sensor (Front RH)                   |             | T18  | Junction Connector  | 90980-12374 |
| T17  | Occupant Classification Sensor (Rear RH)                    | 90980-12353 |      |   |             |
| T18  | Junction Connector  | 90980-12374 |      |   |             |
|      |   |             | U1   | Power Seat Motor (Driver's Seat Slide Control)              | 90980-10825 |
|      |   |             | U2   | Power Seat Motor (Driver's Seat Front Vertical Control)     |             |
|      |   |             | U3   | Power Seat Motor (Driver's Seat Reclining Control)          |             |
|      |   |             | U4   | Power Seat Motor (Driver's Seat Lifter Control)             |             |
|      |   |             | U5   | Power Seat Motor (Driver's Seat Lumbar Support Control)     |             |
|      |   |             | U6   | Seat Heater (LH)  | 90980-10906 |
|      |   |             | U7   | Power Seat SW (Driver's Seat)                               | 90980-10997 |
|      |   |             | U8   | Power Seat SW (Driver's Seat Lumbar Support Control)        | 90980-10789 |
|      |   |             | U11  | Junction Connector  | 90980-12374 |
|      |   |             | V1   | Knock Control Sensor (Bank 2)                               | 90980-11875 |
|      |   |             | V2   | Knock Control Sensor (Bank 1)                               |             |
|      |   |             | W1   | Door Outside Handle (Front RH)                              | 90980-12382 |
|      |   |             | W2   | Electrical Key Oscillator (Front Door RH)                   | 90980-12380 |
|      |   |             | X1   | Door Outside Handle (Front LH)                              | 90980-12382 |
|      |   |             | X2   | Electrical Key Oscillator (Front Door LH)                   | 90980-12380 |
|      |   |             | Y1   | Side Airbag Squib (RH)                                      | 90980-12452 |
|      |   |             | Z1   | Side Airbag Squib (LH)                                      |             |
|      |   |             | a1   | Spiral Cable  | 90980-12361 |
|      |   |             |      | Steering Pad SW   |             |
|      |   |             | b1   | Cruise Control SW   | 90980-12360 |
|      |   |             |      | Spiral Cable  |             |
|      |   |             | c1   | Airbag Squib (Front Passenger's Airbag Assembly)            | 90980-12219 |
|      |   |             | c2   | Airbag Squib (Front Passenger's Airbag Assembly)            | 90980-12224 |
|      |   |             | d1   | Occupant Classification ECU                                 | 90980-12357 |
|      |   |             | d2   | Occupant Classification Sensor (Front LH)                   | 90980-12353 |
|      |   |             | d3   | Occupant Classification Sensor (Rear LH)                    |             |
|      |   |             | d4   | Occupant Classification Sensor (Front RH)                   |             |
|      |   |             | d5   | Occupant Classification Sensor (Rear RH)                    |             |
|      |   |             | e1   | A/C Amplifier   |             |
|      |   |             |      | A/C Blower Assembly   |             |
|      |   |             | f1   | Speed Sensor (Rear LH)                                      | 90980-10860 |
|      |   |             | g1   | Speed Sensor (Rear RH)                                      |             |



HOW TO READ THIS SECTION

\* The system shown here is an EXAMPLE ONLY. It is different to the actual circuit shown in the wiring diagram section.

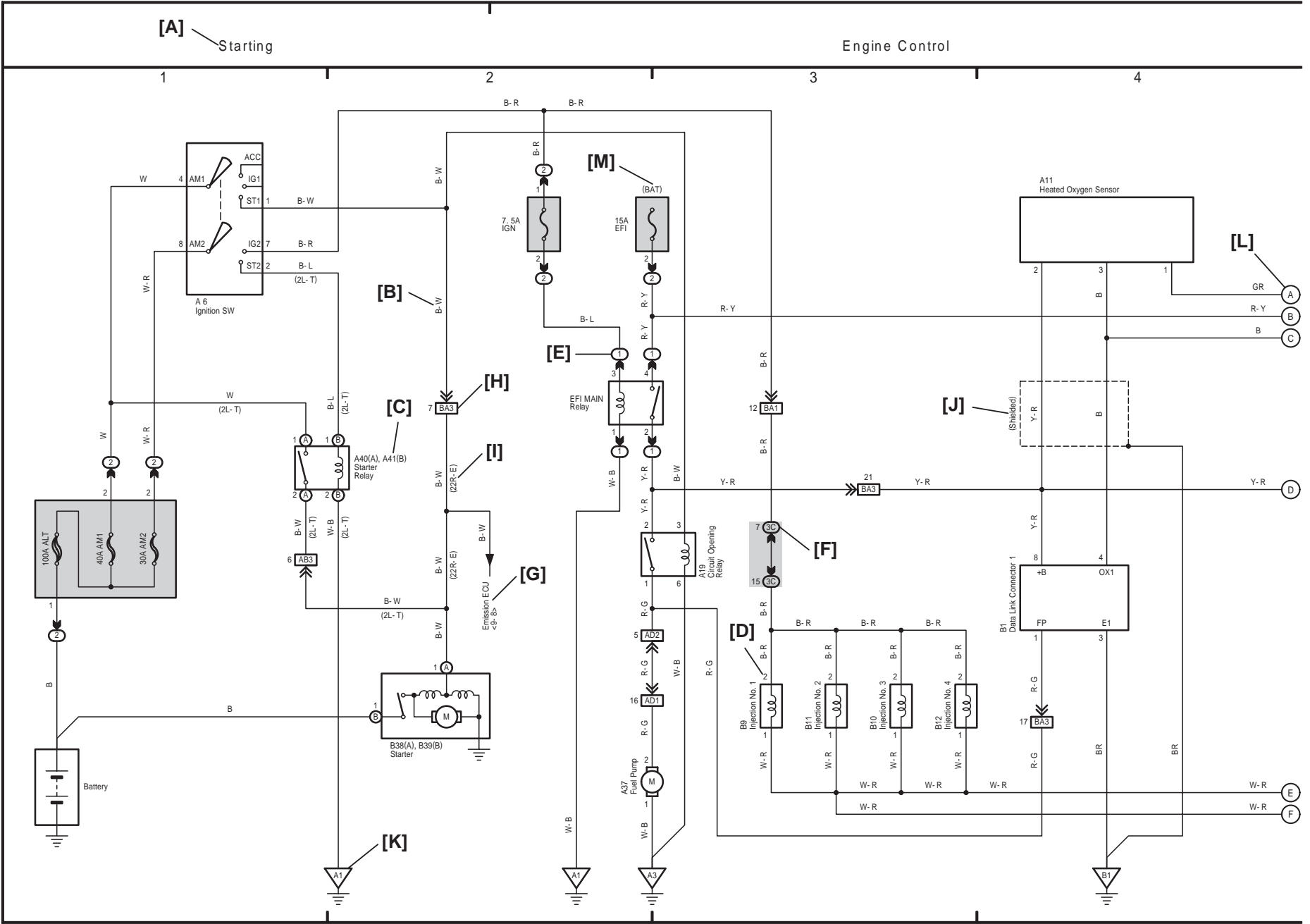

**[A]** : System Title

**[B]** : Indicates the wiring color.

Wire colors are indicated by an alphabetical code.

B = Black    W = White    BR = Brown  
 L = Blue    V = Violet    SB = Sky Blue  
 R = Red    G = Green    LG = Light Green  
 P = Pink    Y = Yellow    GR = Gray  
 O = Orange

The first letter indicates the basic wire color and the second letter indicates the color of the stripe.

Example: L – Y

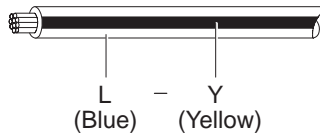

**[C]** : The position of the parts is the same as shown in the wiring diagram and wire routing.

**[D]** : Indicates the pin number of the connector. The numbering system is different for female and male connectors.

Example: Numbered in order from upper left to lower right

Numbered in order from upper right to lower left

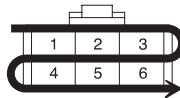

Female

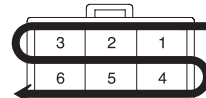

Male

The numbering system for the overall wiring diagram is the same as above

**[E]** : Indicates a Relay Block. No shading is used and only the Relay Block No. is shown to distinguish it from the J/B.

Example:  Indicates Relay Block No.1

**[F]** : Junction Block (The number in the circle is the J/B No. and the connector code is shown beside it). Junction Blocks are shaded to clearly separate them from other parts.

Example:

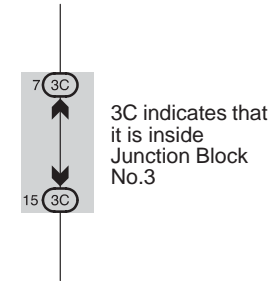

**[G]** : Indicates related system.

**[H]** : Indicates the wiring harness and wiring harness connector. The wiring harness with male terminal is shown with arrows (↘). Outside numerals are pin numbers.

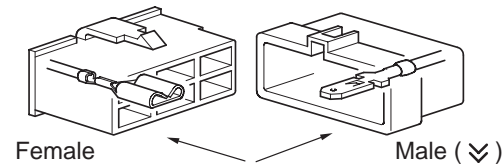

**[I]** : ( ) is used to indicate different wiring and connector, etc. when the vehicle model, engine type, or specification is different.

**[J]** : Indicates a shielded cable.



**[K]** : Indicates a ground point.

**[L]** : The same code occurring on the next page indicates that the wire harness is continuous.

**[M]** : Indicates the ignition key position(s) when the power is supplied to the fuse(s).

## SYSTEM INDEX

| SYSTEMS  | LOCATION | SYSTEMS   | LOCATION |
|--|----------|---|----------|
| ABS (w/ VSC TMC Made) .....  | 12-1     | * Key Reminder                                      |          |
| ABS (w/ VSC TMMK Made) .....   | 13-1     | * Light Auto Turn Off System                        |          |
| ABS (w/o VSC) .....  | 14-1     | * Luggage Compartment Door Opener                   |          |
| Air Conditioning .....   | 27-1     | * Power Window                                      |          |
| Audio System (6 Speaker) .....   | 24-1     | * Seat Belt Warning                                 |          |
| Audio System (8 Speaker w/ Navigation System) .....                        | 22-1     | * Taillight   |          |
| Audio System (8 Speaker w/o Navigation System) .....                       | 23-1     | * Theft Deterrent                                   |          |
| Automatic Glare-Resistant EC Mirror .....                                  | 17-4     | * Wireless Door Lock Control (w/o Smart Key System) |          |
| Back-Up Light .....  | 10-1     | Navigation System .....                             | 22-1     |
| Charging .....   | 4-3      | Power Outlet .....                                  | 21-1     |
| Clock .....  | 17-1     | Power Seat (Driver's Seat) .....                    | 20-1     |
| Combination Meter .....  | 25-1     | Power Seat (Front Passenger's Seat) .....           | 20-3     |
| Cooling Fan (2GR-FE) .....   | 26-1     | Power Source .....                                  | 1-1      |
| Cruise Control (2AZ-FE) .....  | 8-13     | Radiator Fan and Condenser Fan (2AZ-FE) .....       | 26-3     |
| Cruise Control (2GR-FE) .....  | 2-18     | Rear Window Defogger .....                          | 18-3     |
| Data Link Connector 3 .....  | 9-1      | Remote Control Mirror .....                         | 18-1     |
| Electronically Controlled Transmission and A/T Indicator<br>(2AZ-FE) ..... | 8-14     | Seat Heater .....                                   | 19-3     |
| Electronically Controlled Transmission and A/T Indicator<br>(2GR-FE) ..... | 2-19     | Shift Lock .....                                    | 21-4     |
| Engine Control (2AZ-FE) .....  | 8-1      | Sliding Roof .....                                  | 17-2     |
| Engine Control (2GR-FE) .....  | 7-1      | Smart Key System .....                              | 3-1      |
| Engine Immobiliser System (w/o Smart Key System) .....                     | 9-3      | * Engine Immobiliser                                |          |
| Horn .....   | 21-2     | * Push Button Start System                          |          |
| Ignition (2AZ-FE) .....  | 6-1      | * Steering Lock                                     |          |
| Ignition (2GR-FE) .....  | 5-1      | * Wireless Door Lock Control                        |          |
| Mirror Heater .....  | 18-3     | SRS .....   | 15-1     |
| Multiplex Communication System (CAN) .....                                 | 2-1      | Starting (w/o Smart Key System) .....               | 4-1      |
| * Automatic Light Control  |          | Stop Light .....                                    | 10-3     |
| * Door Lock Control  |          | Tire Pressure Warning System .....                  | 16-1     |
| * Fog Light  |          | TRAC (TMC Made) .....                               | 12-1     |
| * Garage Door Opener   |          | TRAC (TMMK Made) .....                              | 13-1     |
| * Headlight  |          | Turn Signal and Hazard Warning Light .....          | 11-1     |
| * Illumination   |          | VSC (TMC Made) .....                                | 12-1     |
| * Interior Light   |          | VSC (TMMK Made) .....                               | 13-1     |
|  |          | Wiper and Washer .....                              | 19-1     |

1 CAMRY

(Cont. next page)

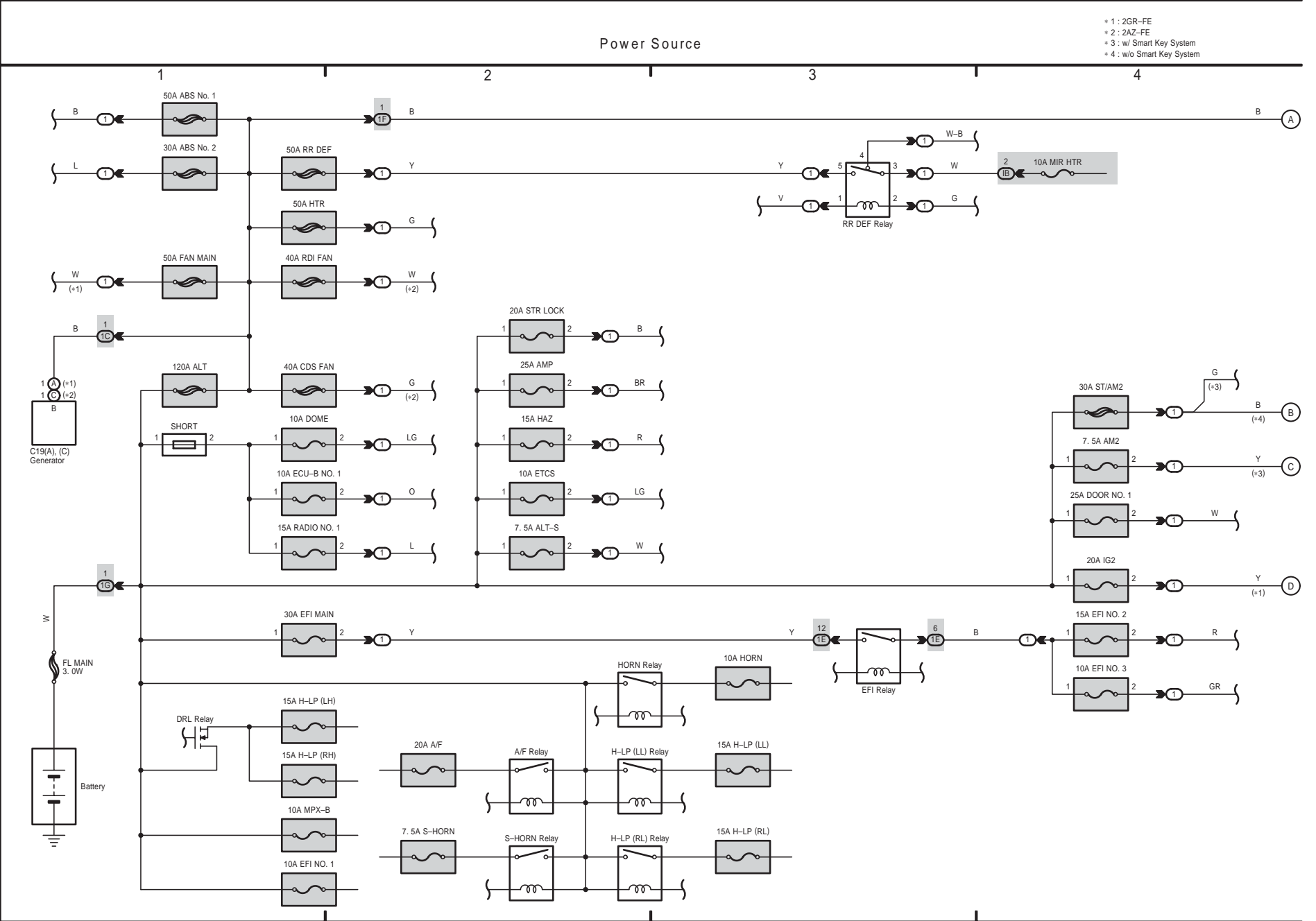

1 CAMRY (Cont' d)

Power Source

- \* 1 : 2GR-FE
- \* 2 : 2AZ-FE
- \* 3 : w/ Smart Key System
- \* 4 : w/o Smart Key System

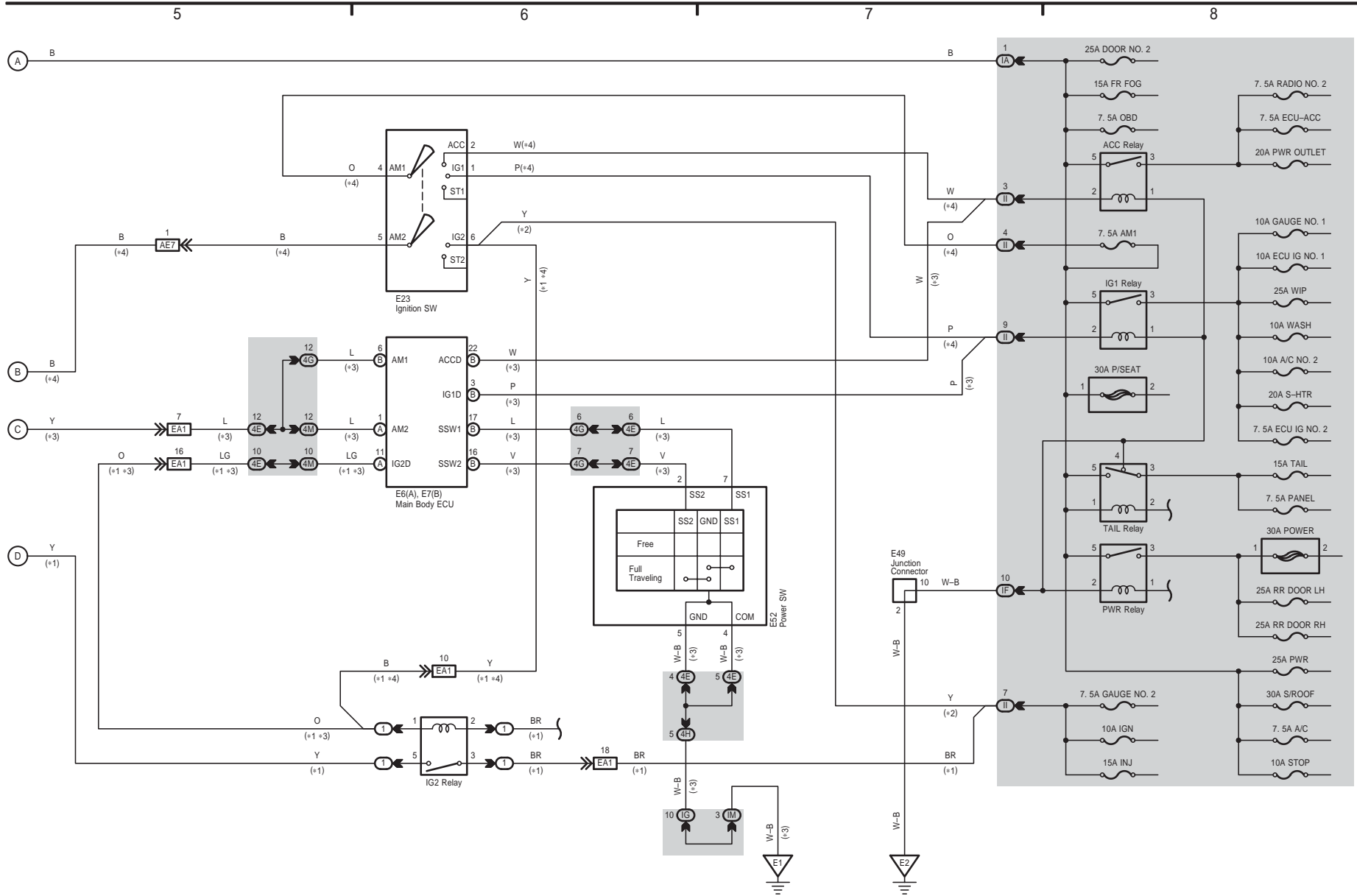

CAMRY (EM0250U)

Multiplex Communication System (CAN)

• 1 : TMC Made  
• 2 : TMMK Made

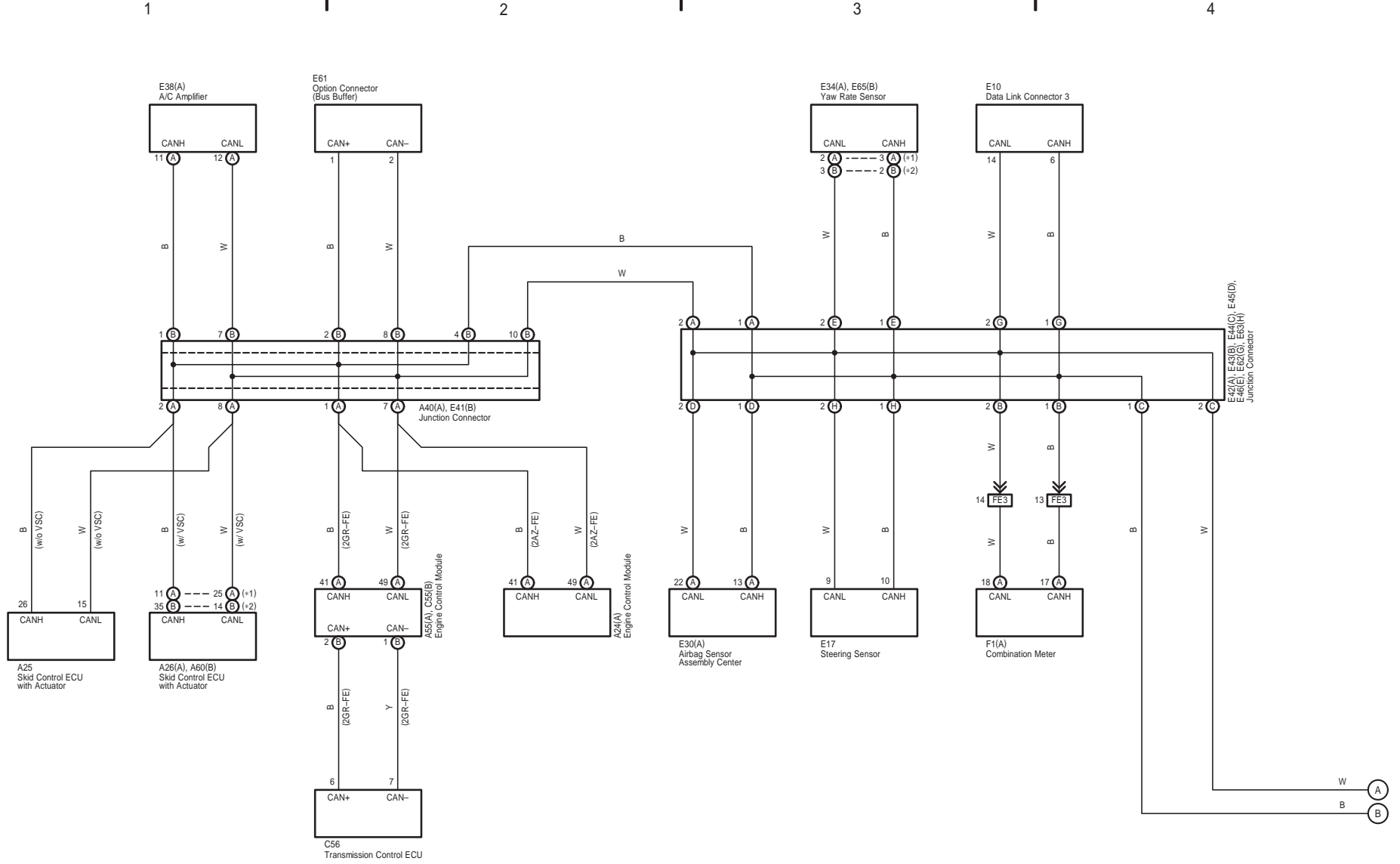

Multiplex Communication System (CAN)

\* 3 : w/ Smart Key System  
 \* 4 : w/o Smart Key System

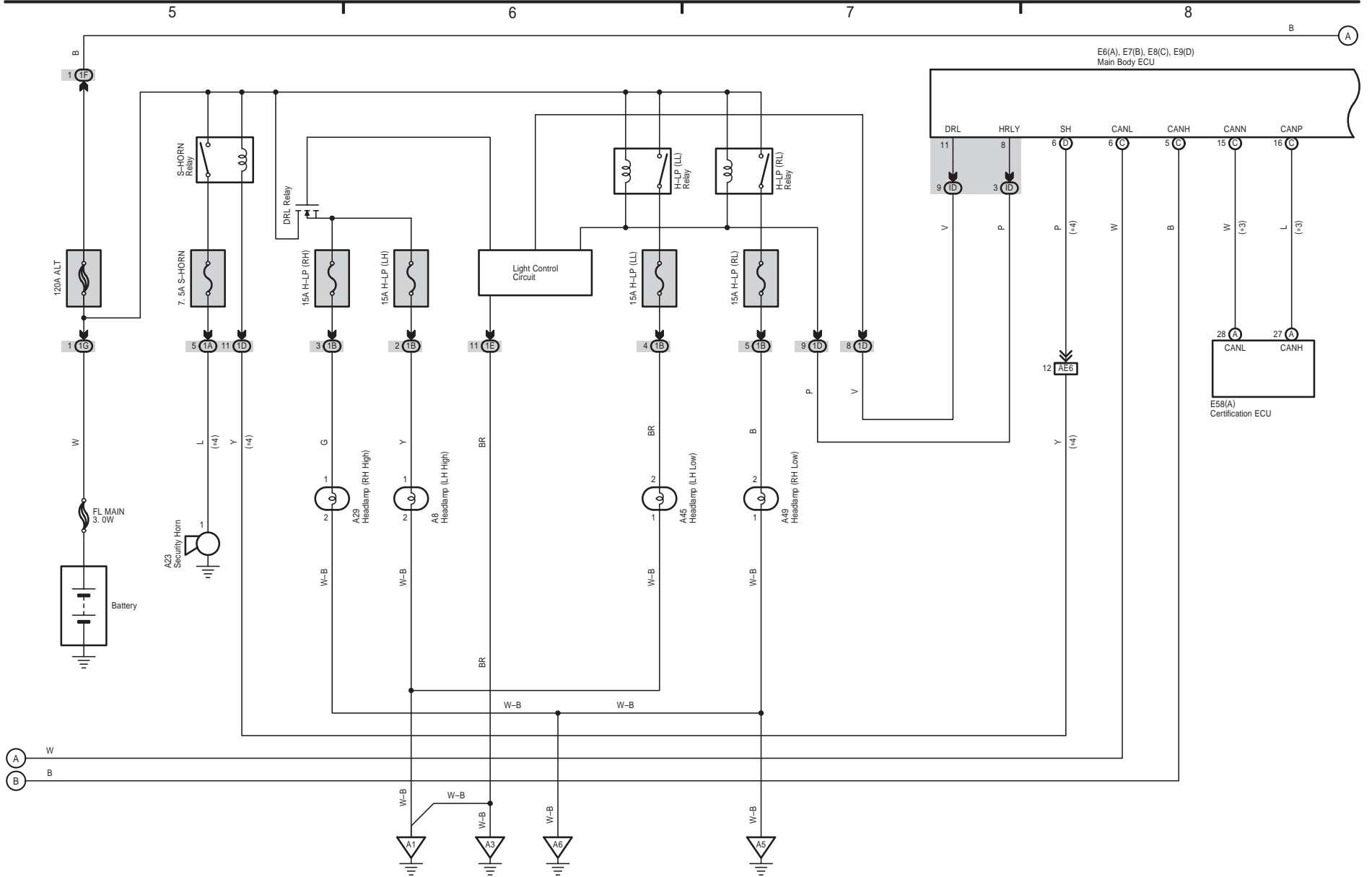

CAMRY (EM0250U)



Multiplex Communication System (CAN)

\* 3 : w/ Smart Key System  
\* 4 : w/o Smart Key System

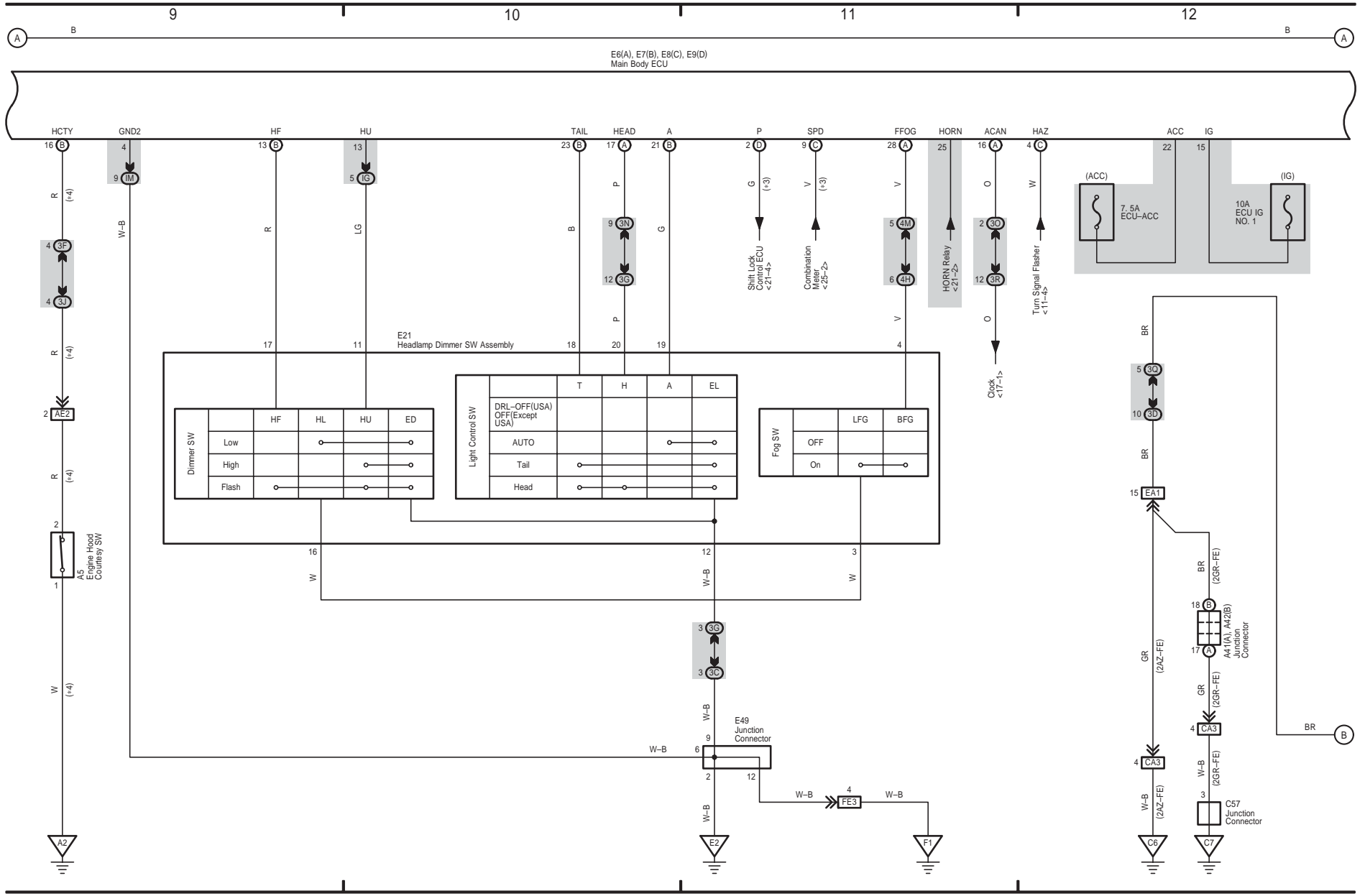





Multiplex Communication System (CAN)

- 3 : w/ Smart Key System
- 4 : w/o Smart Key System
- 5 : w/ Jam Protection
- 6 : w/o Jam Protection

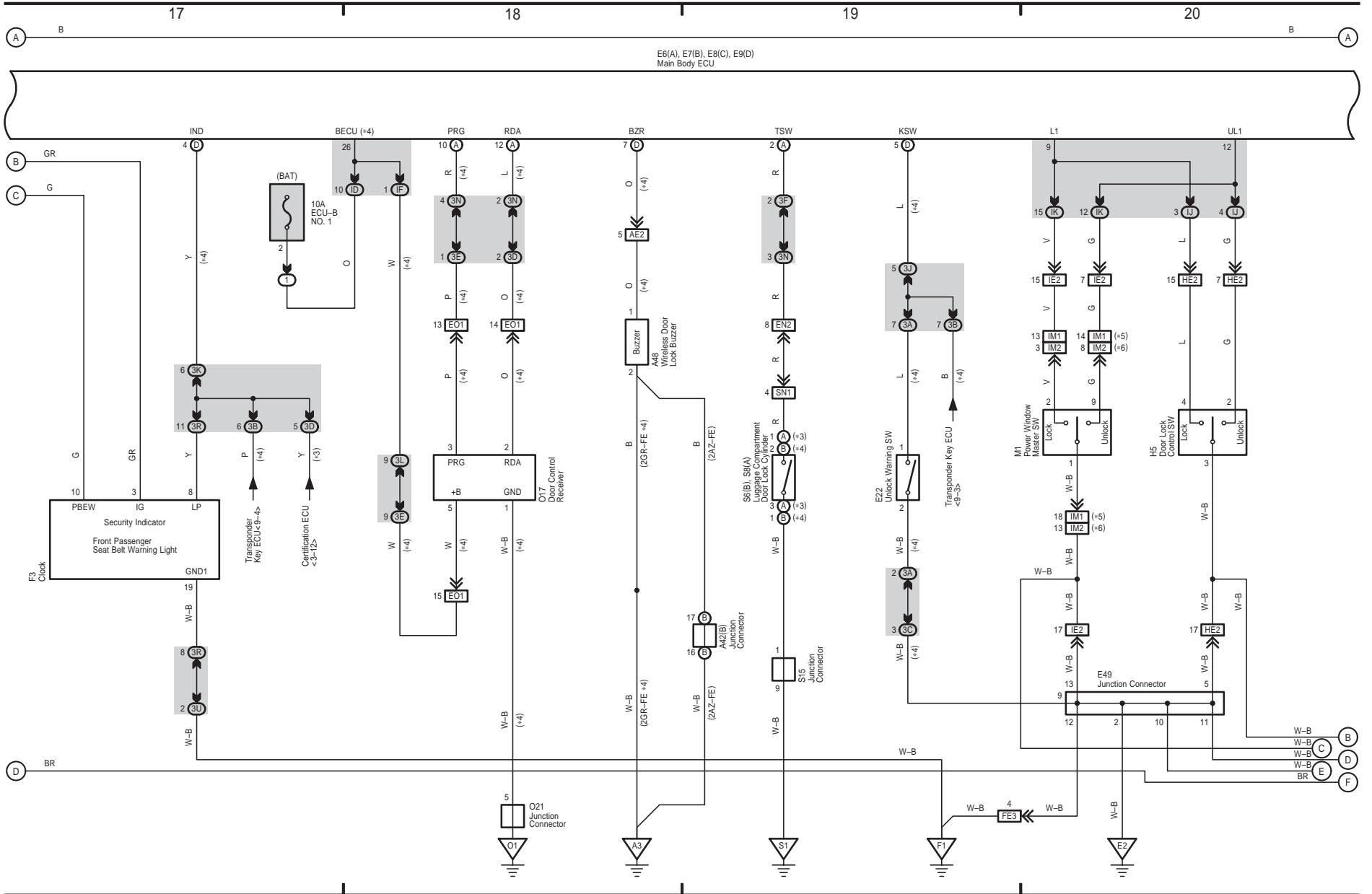

Multiplex Communication System (CAN)

- \* 1 : TMC Made
- \* 2 : TMMK Made
- \* 3 : w/ Smart Key System
- \* 4 : w/o Smart Key System
- \* 7 : w/ Sliding Roof

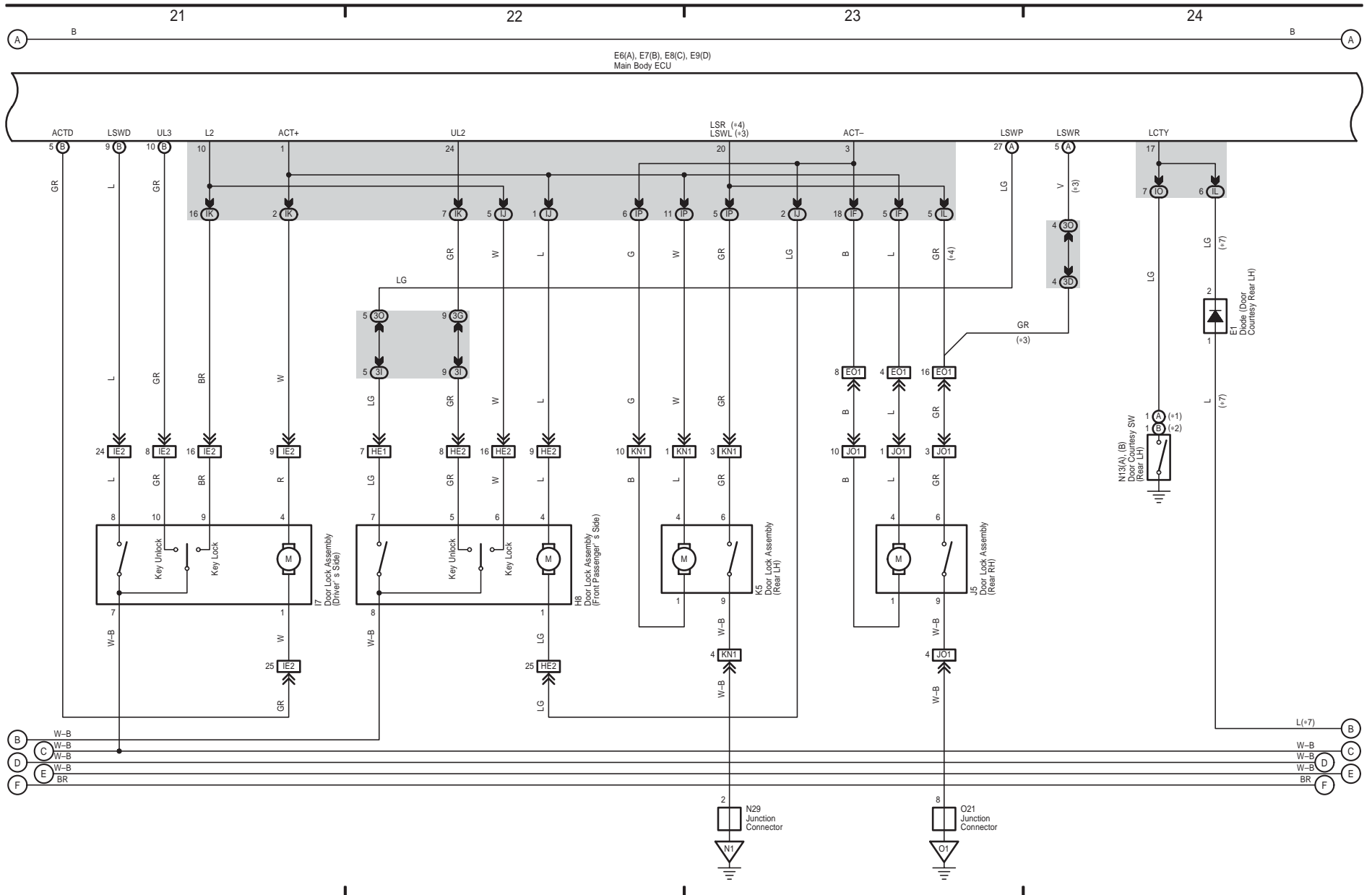

CAMRY (EM0250U)



Multiplex Communication System (CAN)

- \* 1 : TMC Made
- \* 2 : TMMK Made
- \* 3 : w/ Smart Key System
- \* 4 : w/o Smart Key System
- \* 7 : w/ Sliding Roof
- \* 8 : w/o Sliding Roof
- \* 9 : Automatic A/C
- \* 10 : Manual A/C

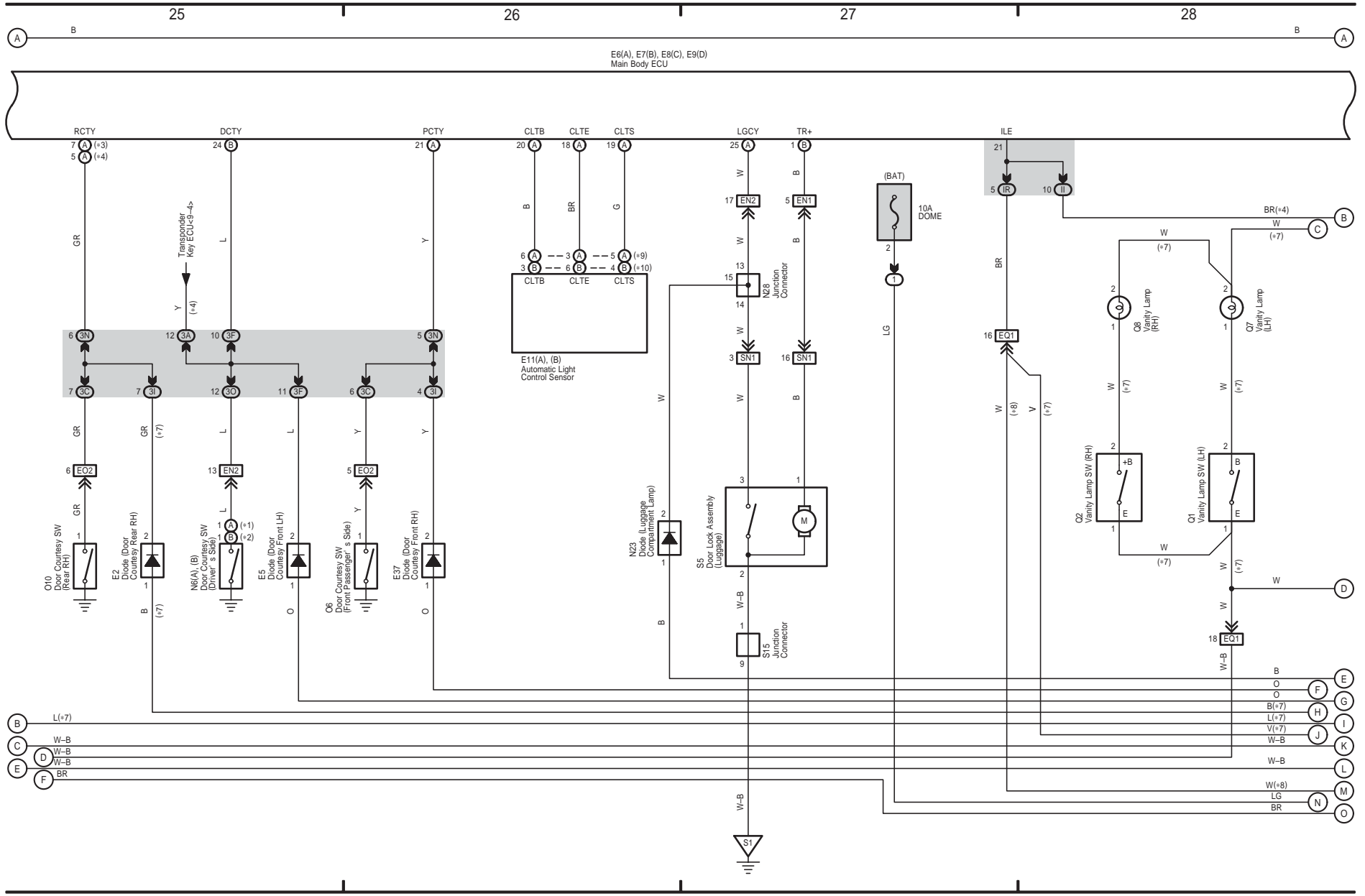

Multiplex Communication System (CAN)

- \* 3 : w/ Smart Key System
- \* 4 : w/o Smart Key System
- \* 7 : w/ Sliding Roof
- \* 8 : w/o Sliding Roof

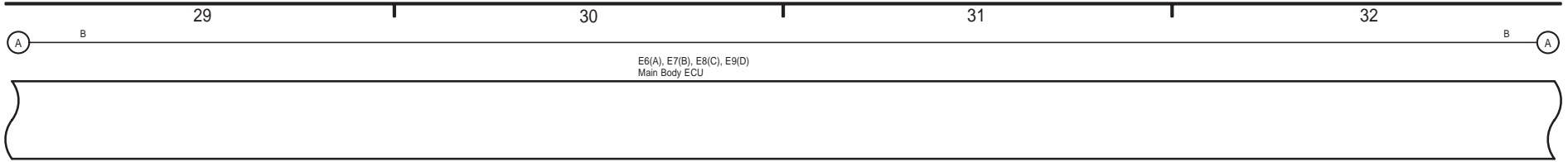

CAMRY (EM0250U)

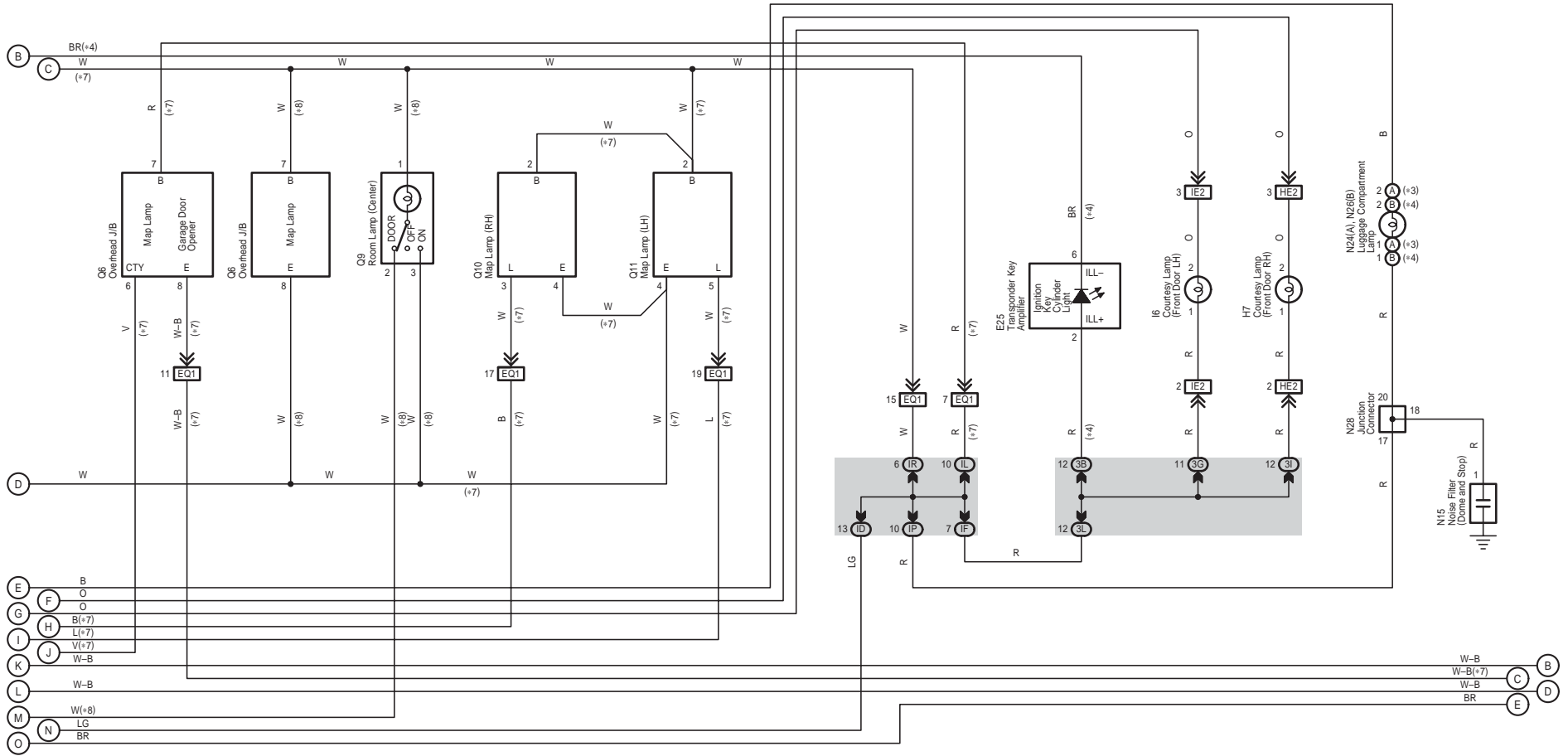

Multiplex Communication System (CAN)

- \* 5 : w/ Jam Protection
- \* 6 : w/o Jam Protection
- \* 7 : w/ Sliding Roof

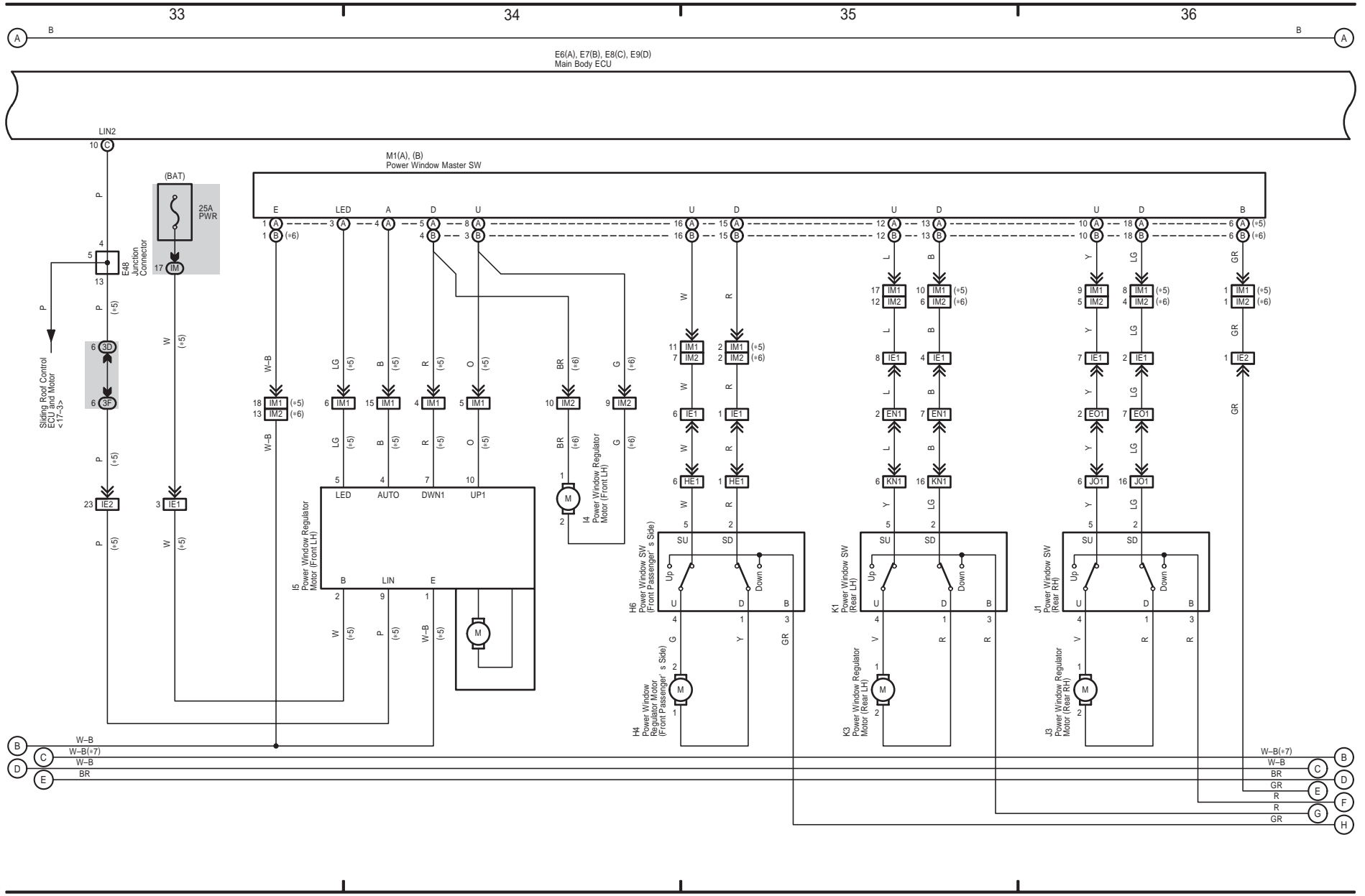

Multiplex Communication System (CAN)

- \* 3 : w/ Smart Key System
- \* 4 : w/o Smart Key System
- \* 7 : w/ Sliding Roof

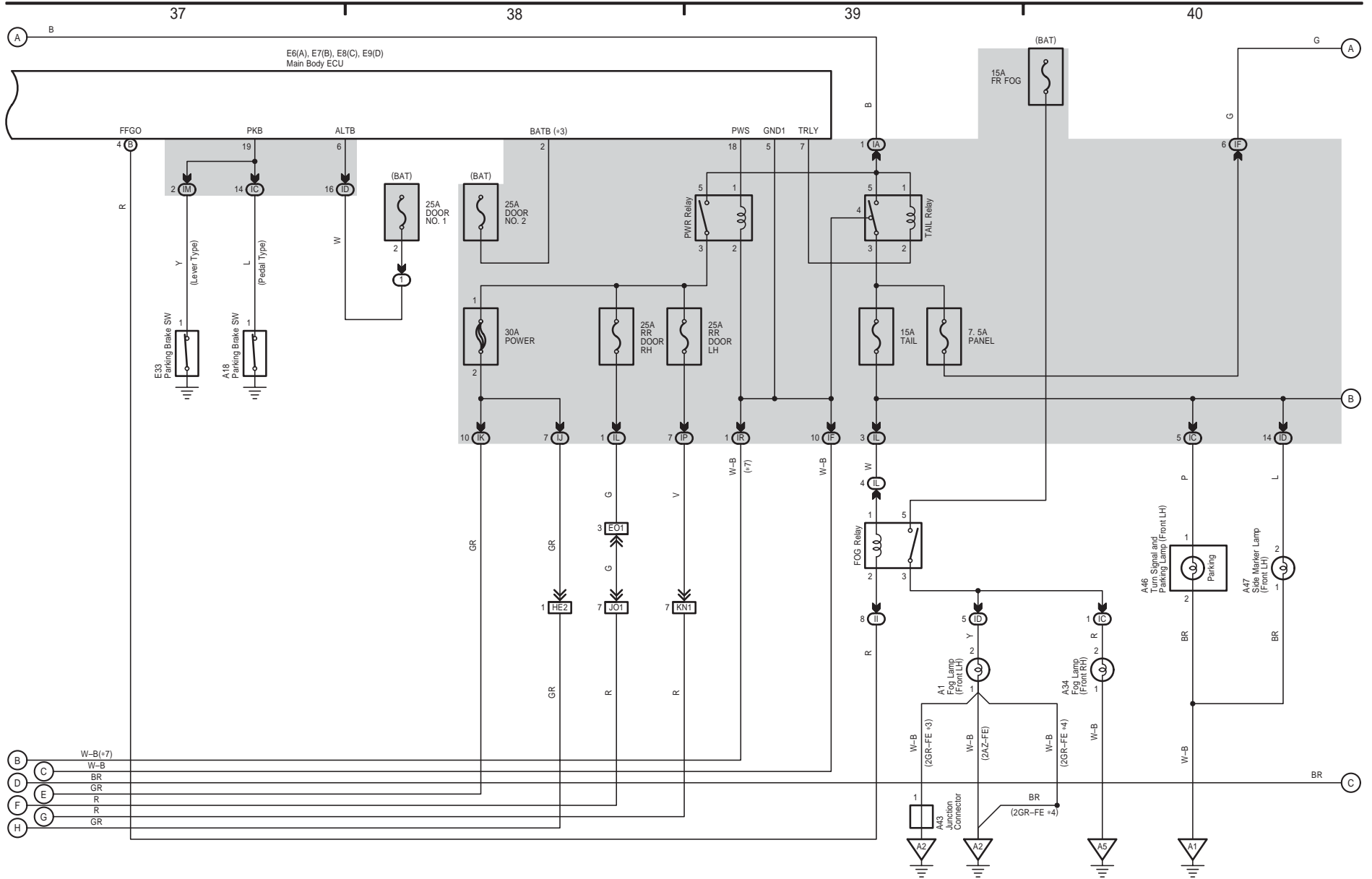

CAMRY (EM0250U)



Multiplex Communication System (CAN)

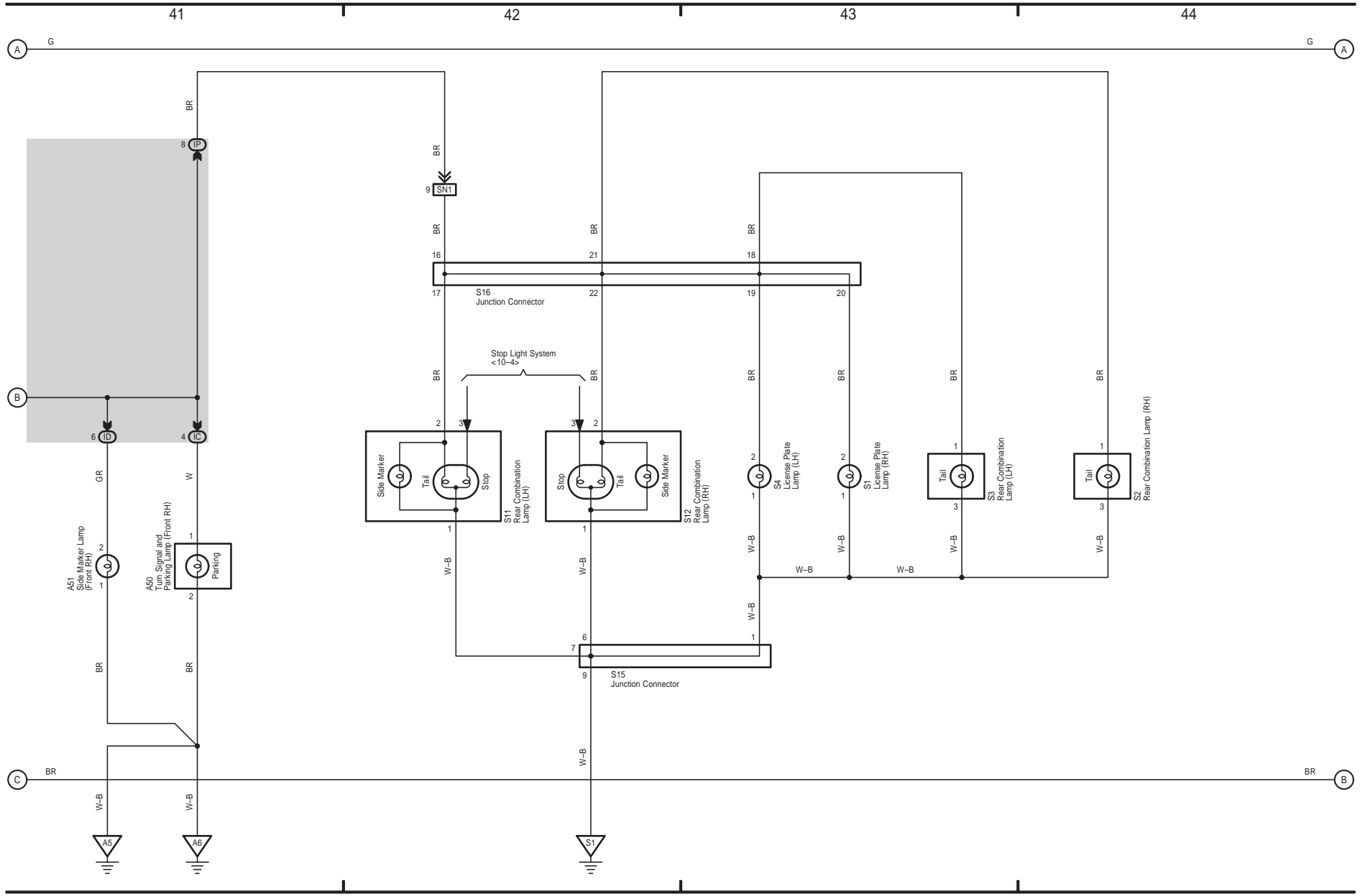





Smart Key System

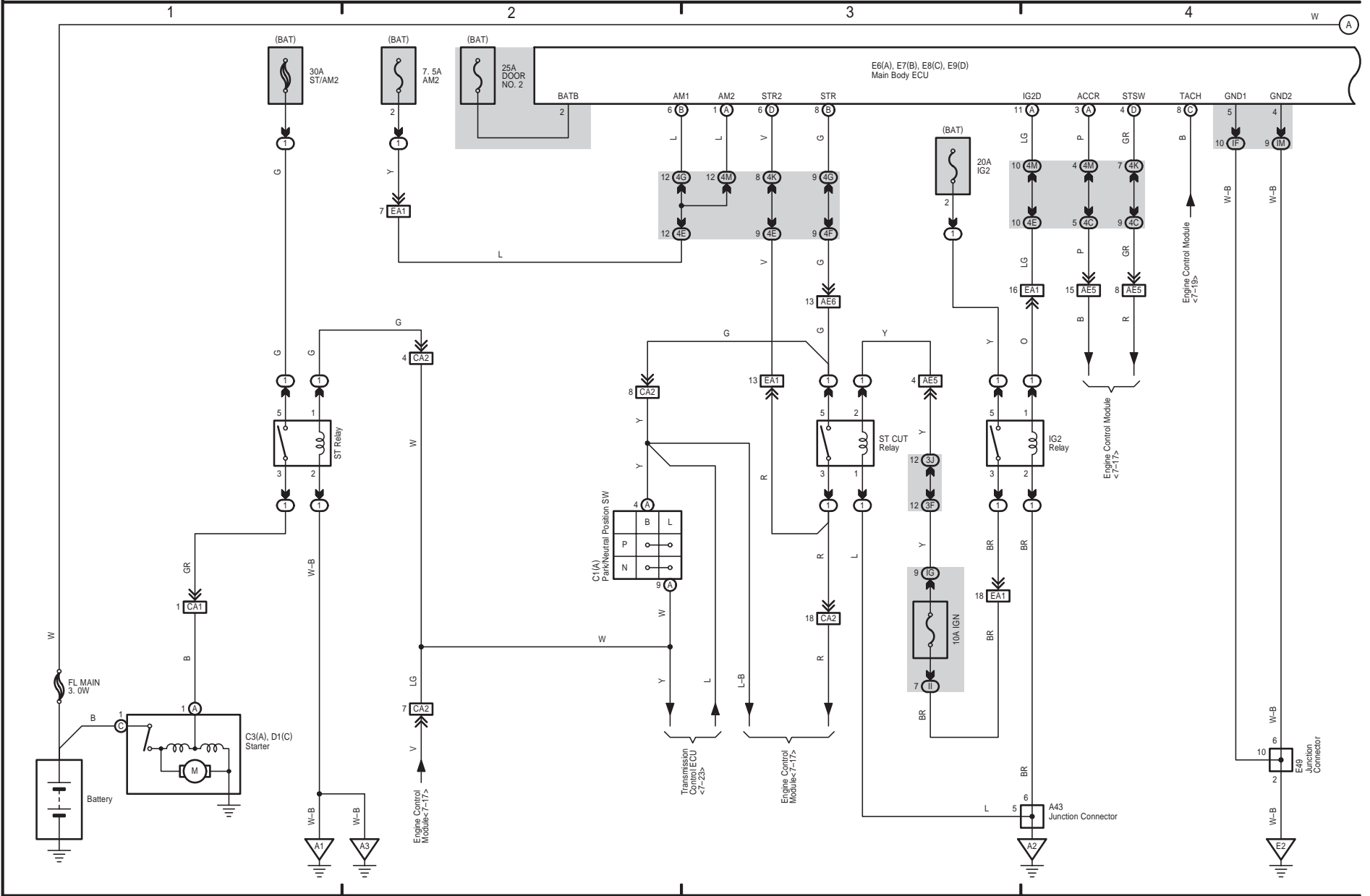

Smart Key System

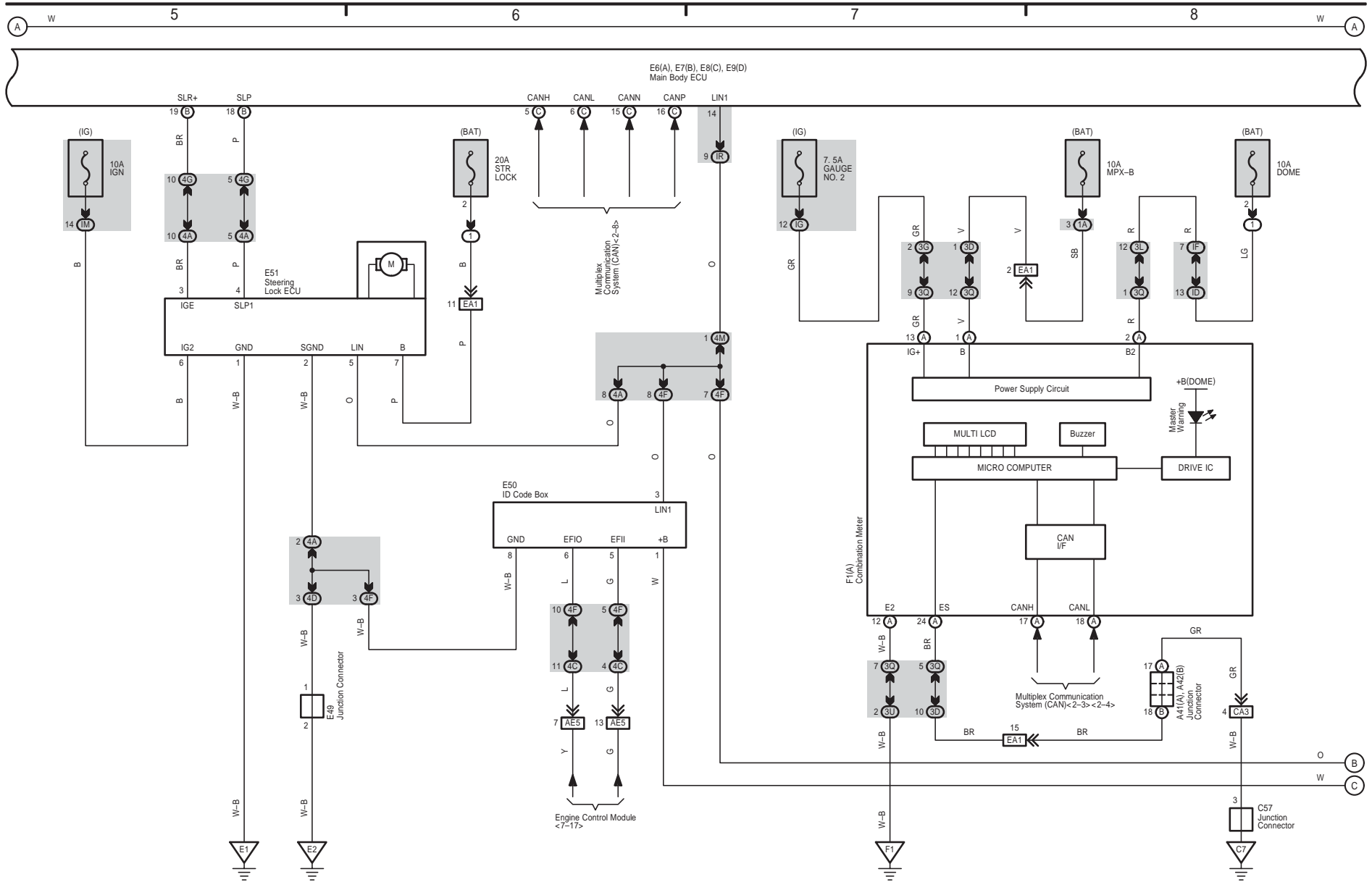

CAMRY (EM0250U)





Smart Key System

CAMRY (EM0250U)

461

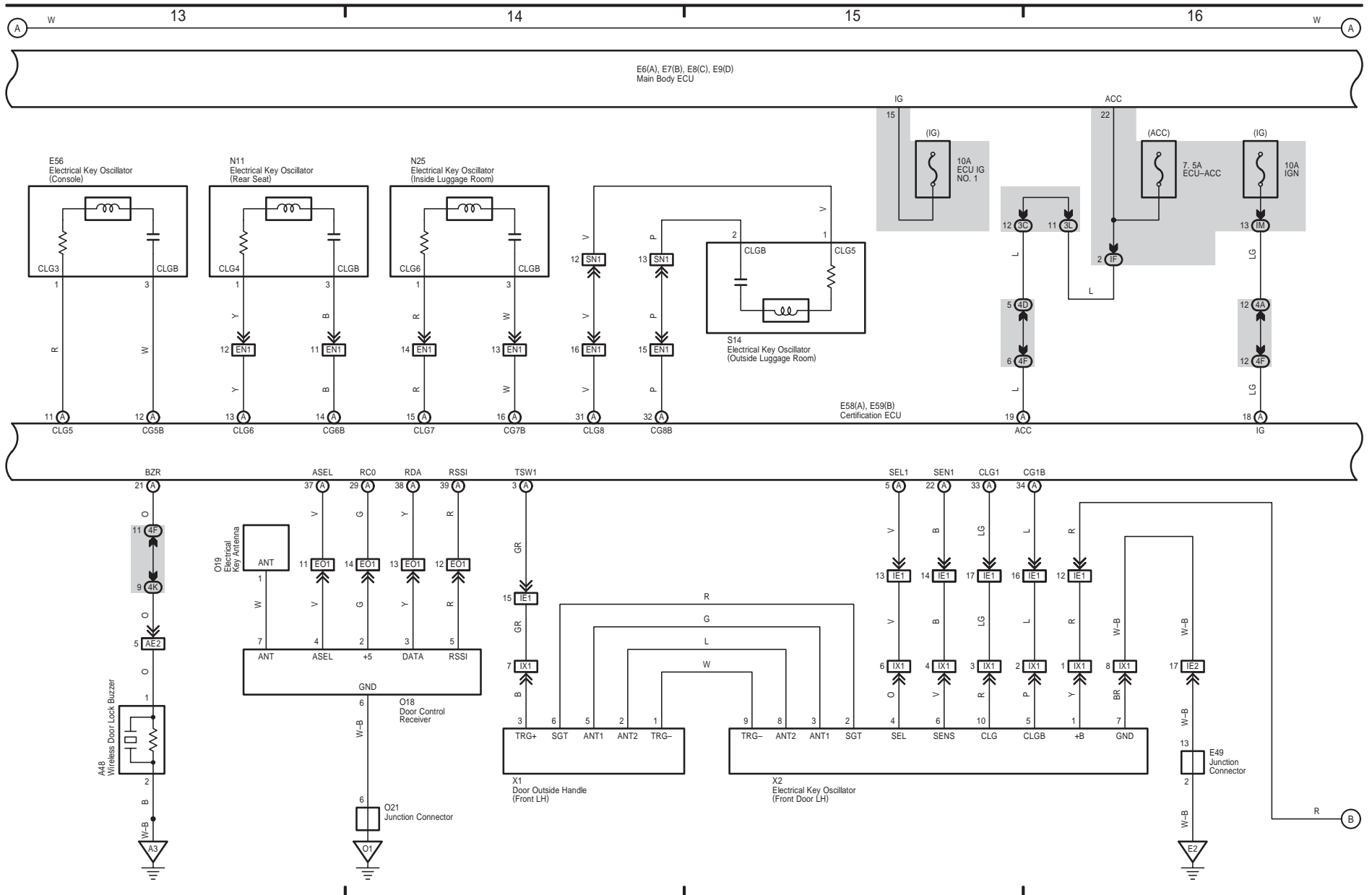

3 CAMRY (Cont' d)

Smart Key System

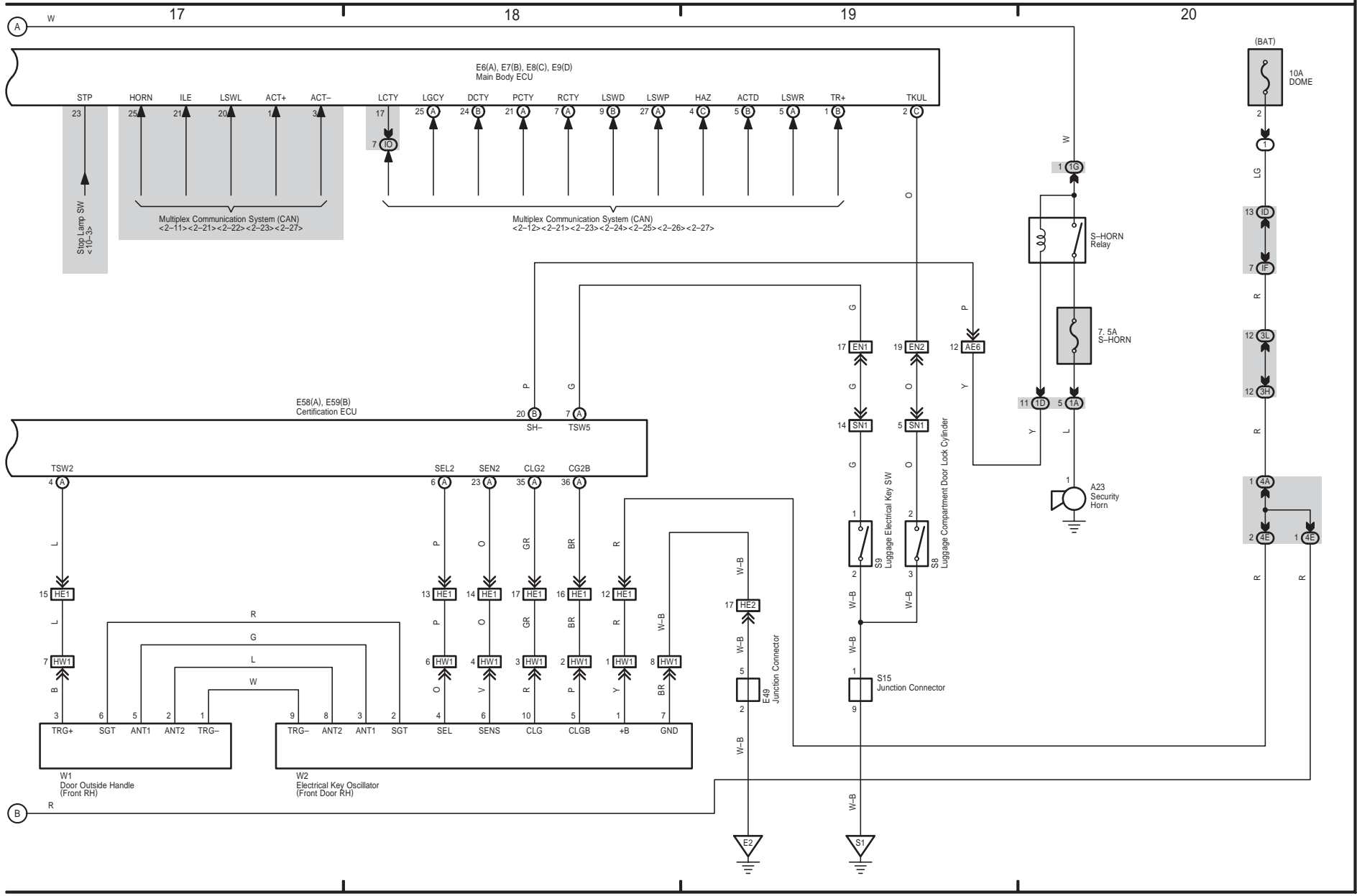

4 CAMRY

Starting (w/o Smart Key System)

Charging

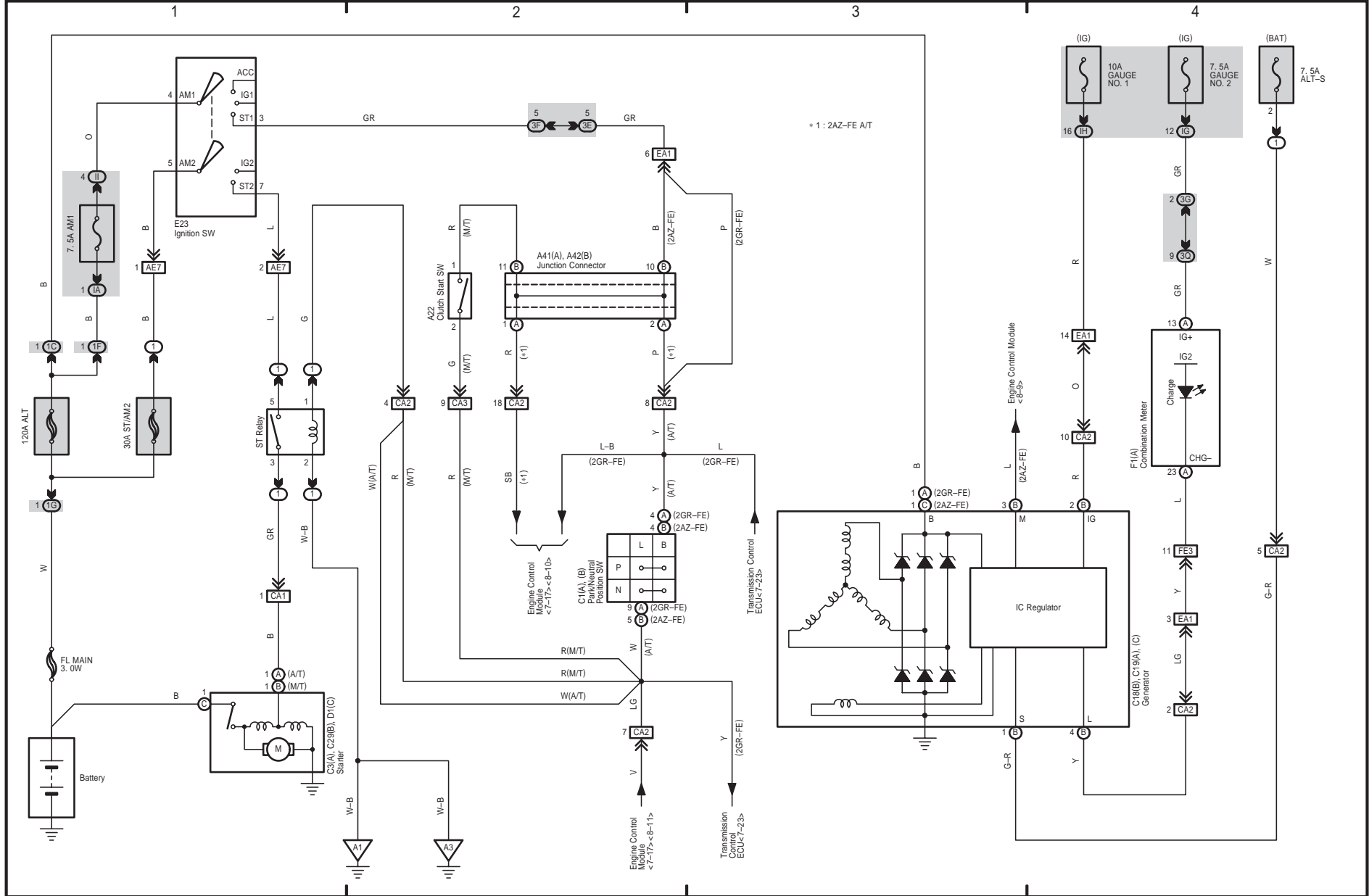

CAMRY (EM0250U)



5 CAMRY

Ignition (2GR-FE)

\* 1 : w/ Smart Key System  
\* 2 : w/o Smart Key System

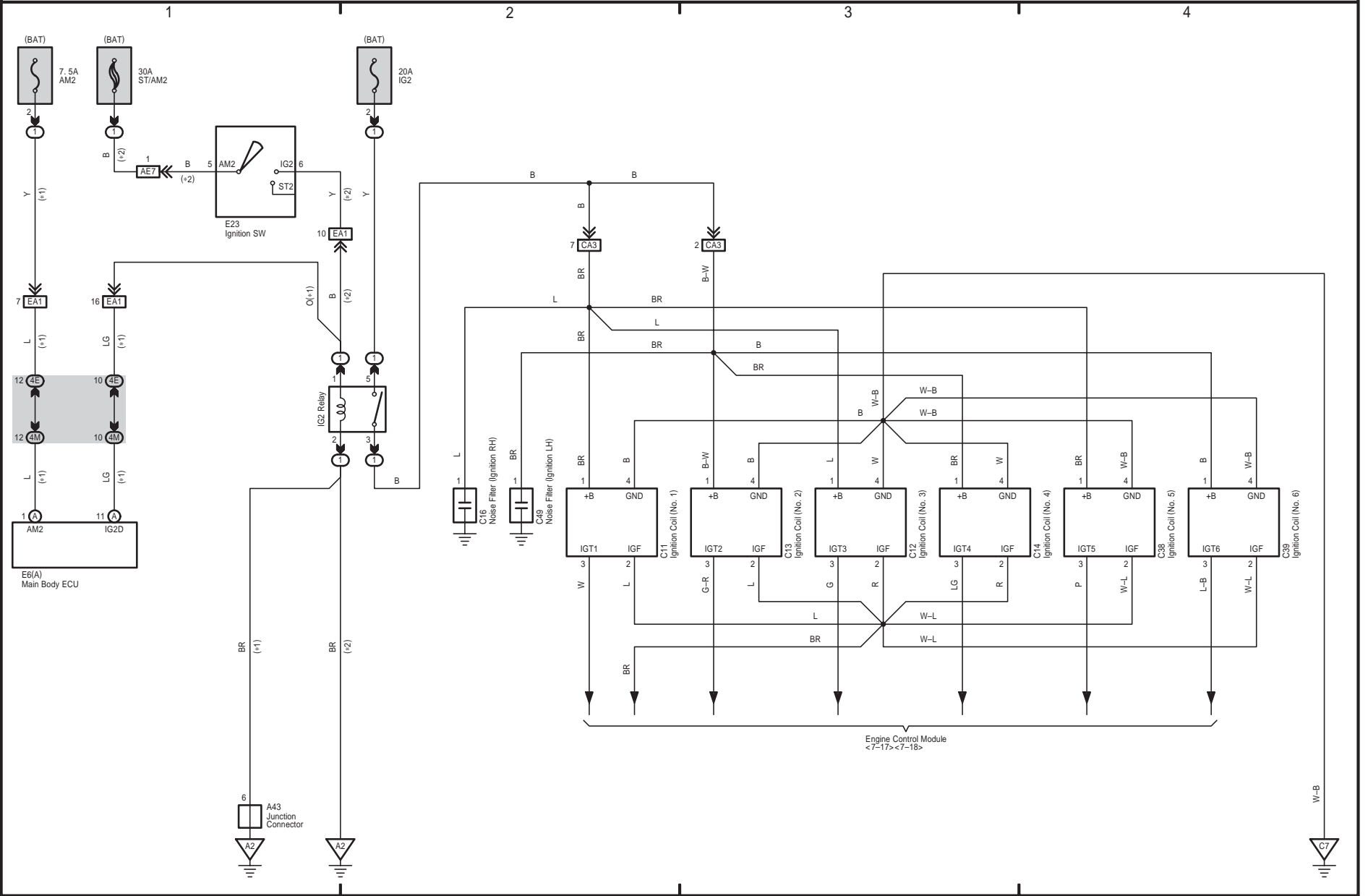



Ignition (2AZ-FE)

1 2 3 4

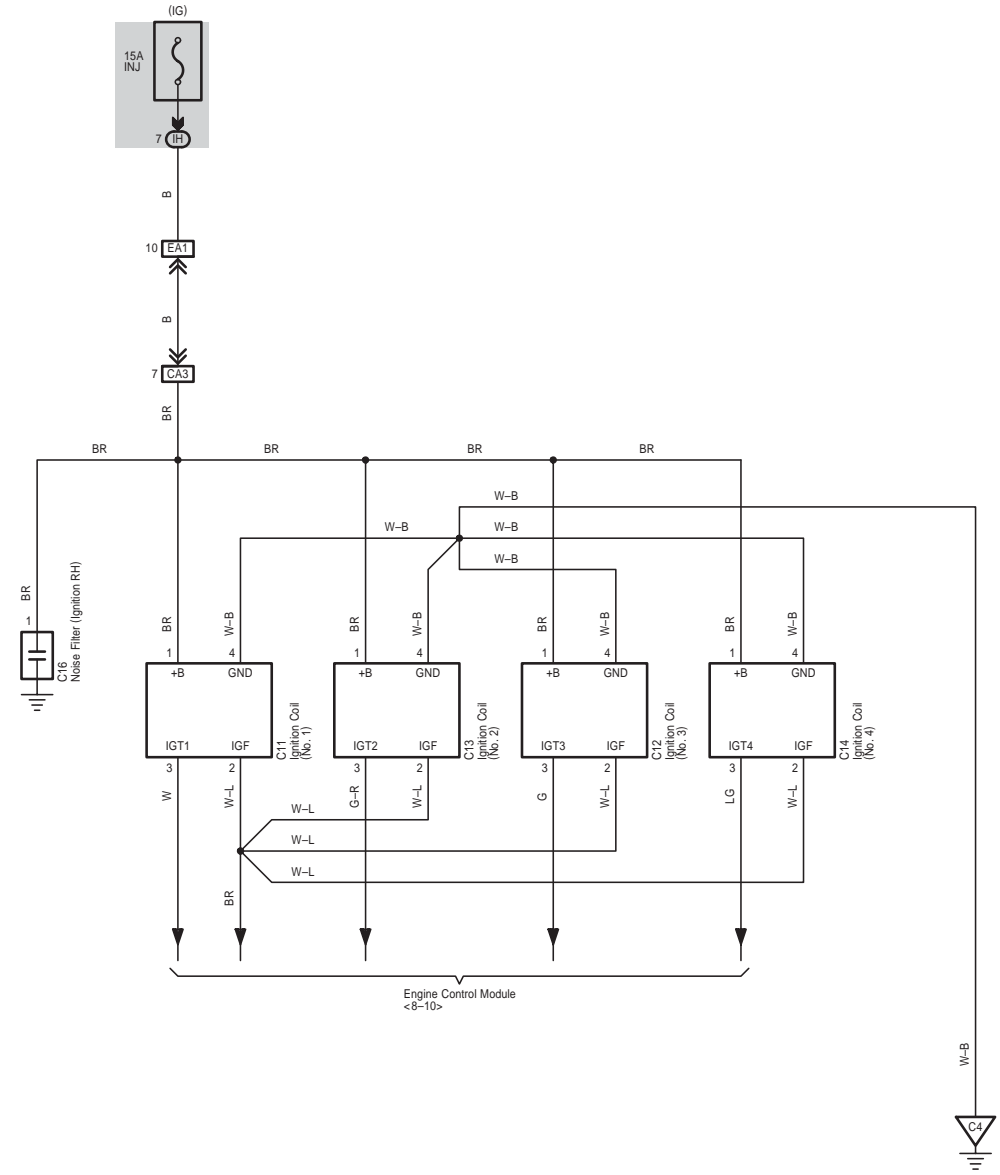

CAMRY (EM0250U)



Engine Control (2GR-FE)

\* 1 : w/ Smart Key System  
\* 2 : w/o Smart Key System

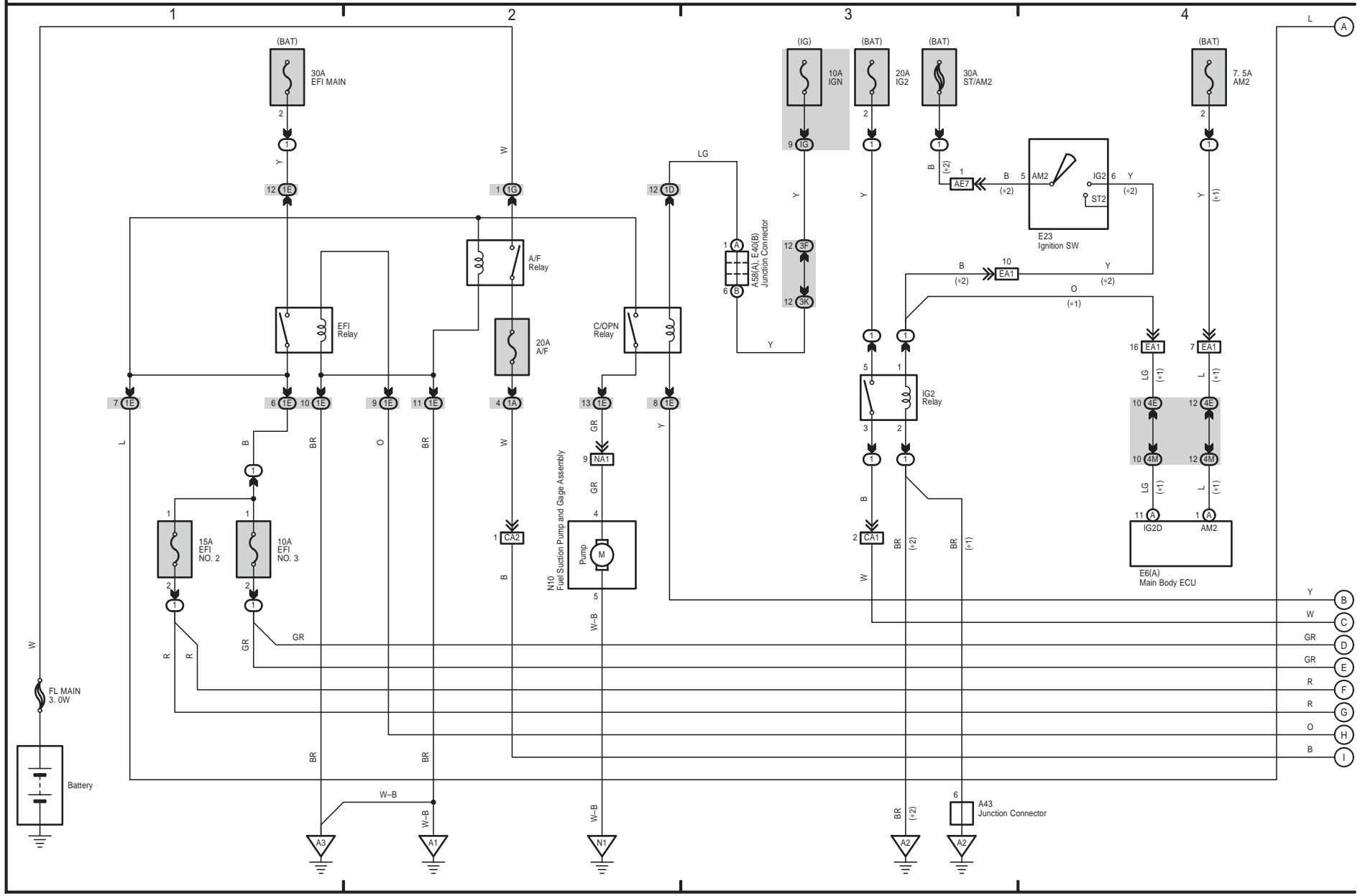

Engine Control (2GR-FE)

CAMRY (EM0250U)

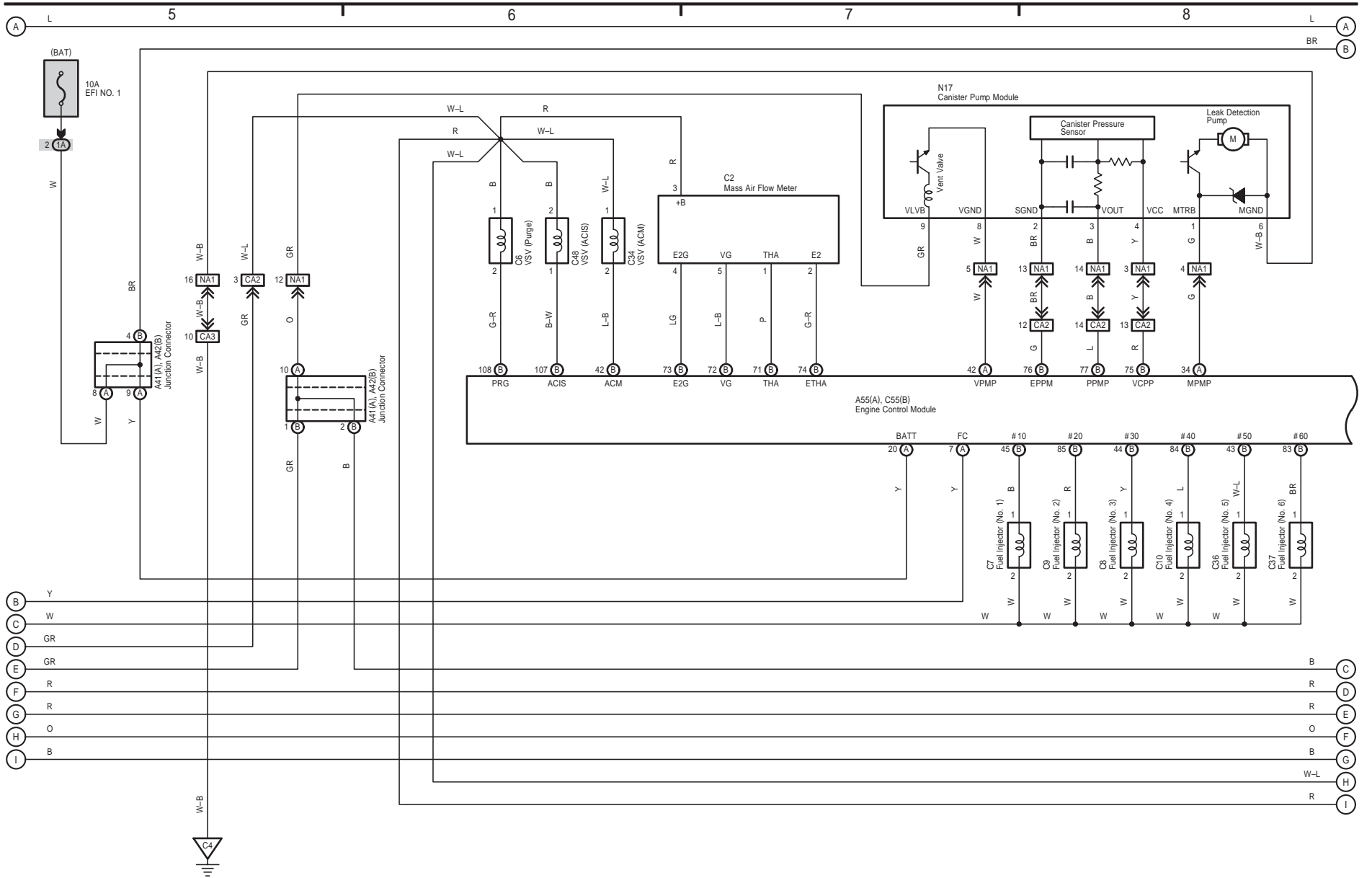



Engine Control (2GR-FE)

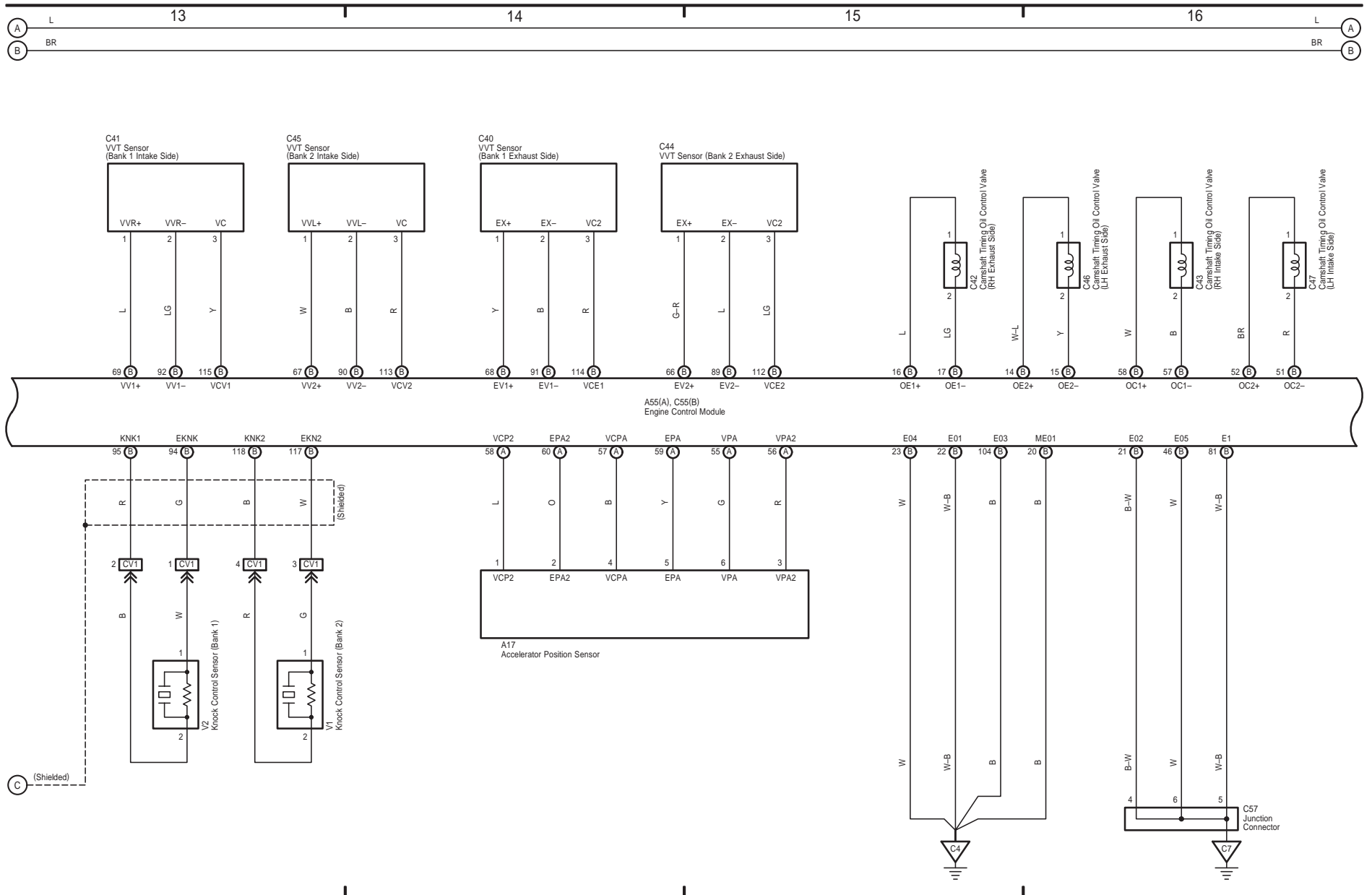

CAMRY (EM0250U)



7 CAMRY (Cont' d)

(Cont. next page)

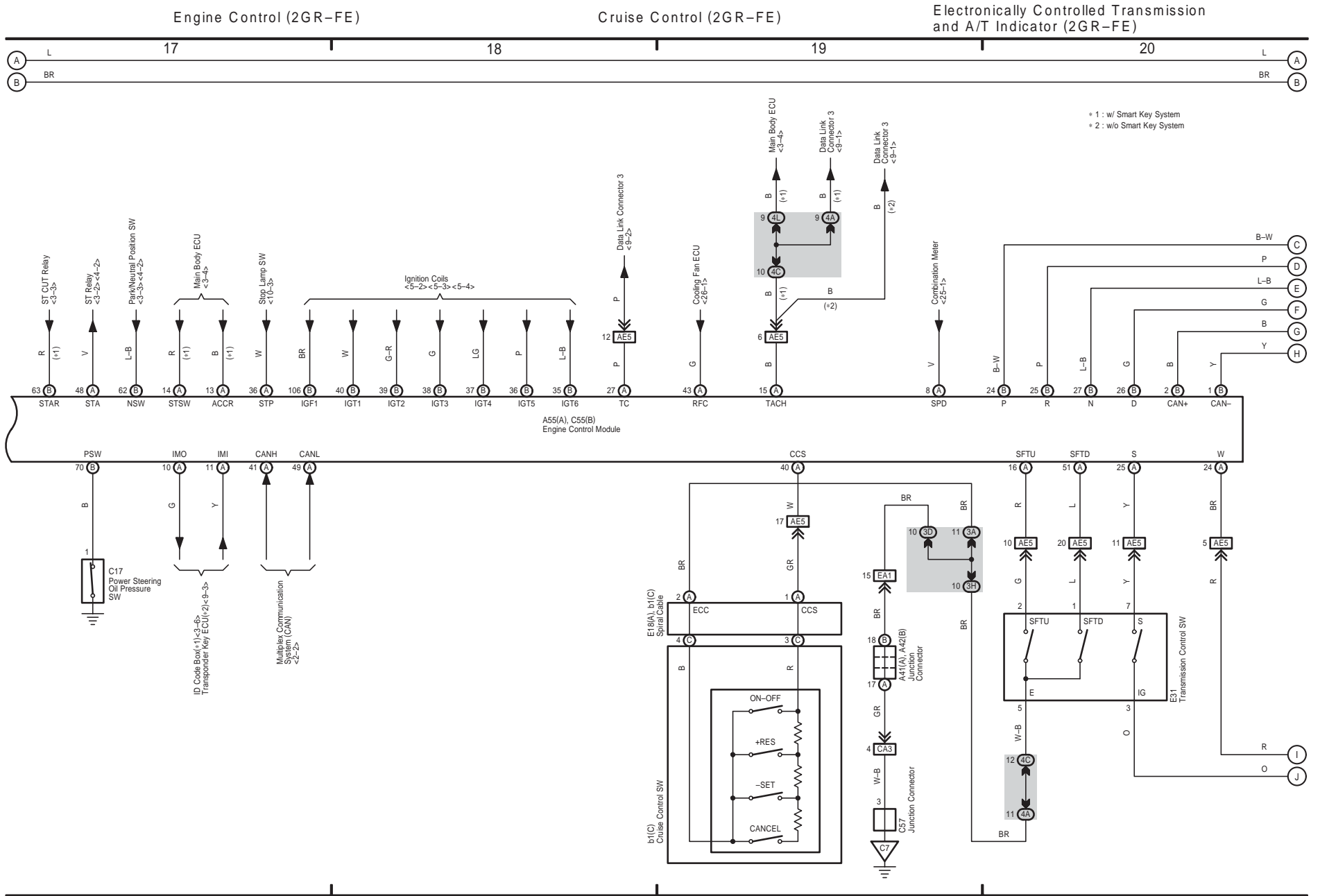

Electronically Controlled Transmission and A/T Indicator (2GR-FE)

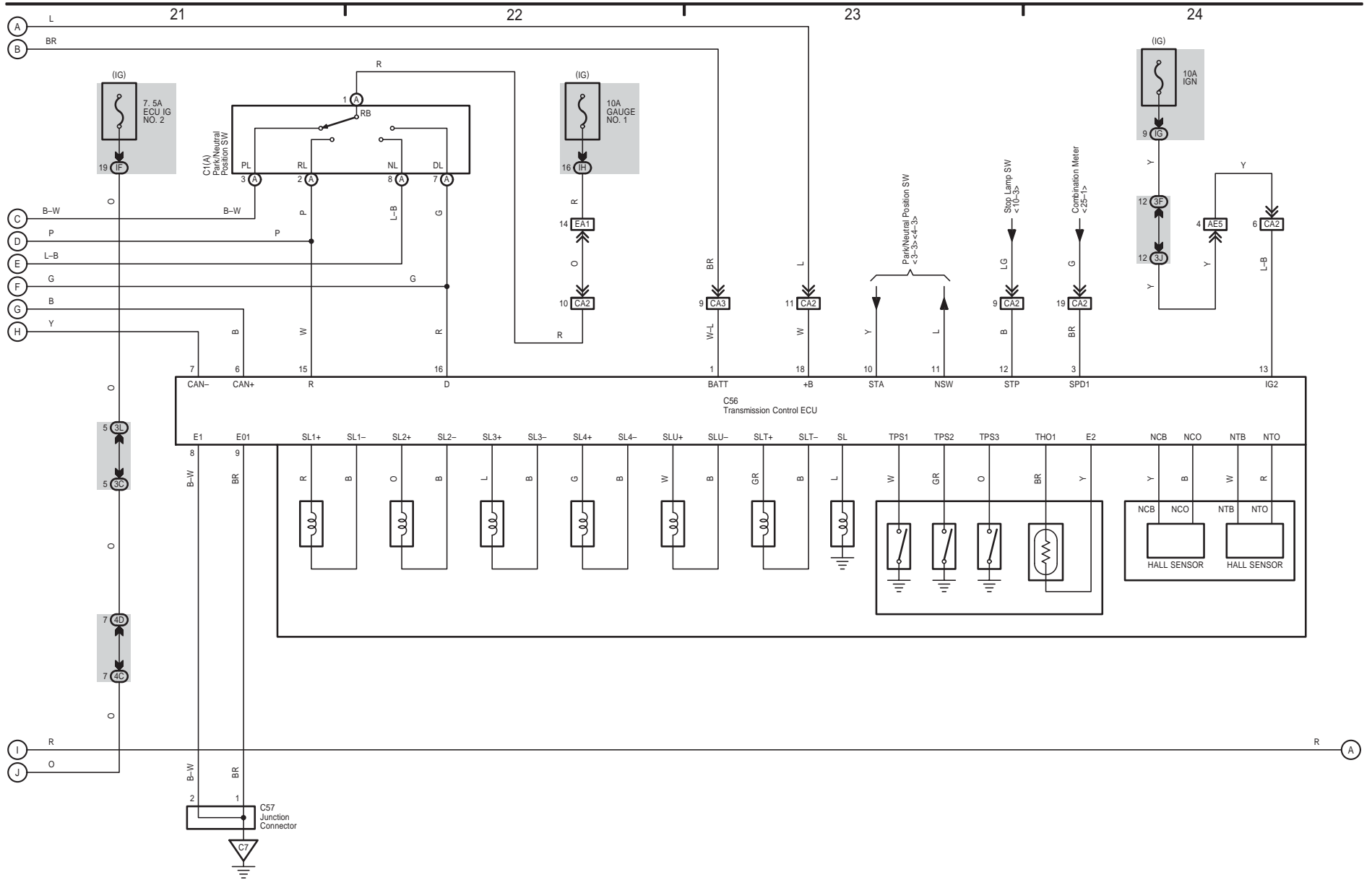

CAMRY (EM0250U)



7 CAMRY (Cont' d)

Electronically Controlled Transmission and A/T Indicator (2GR-FE)

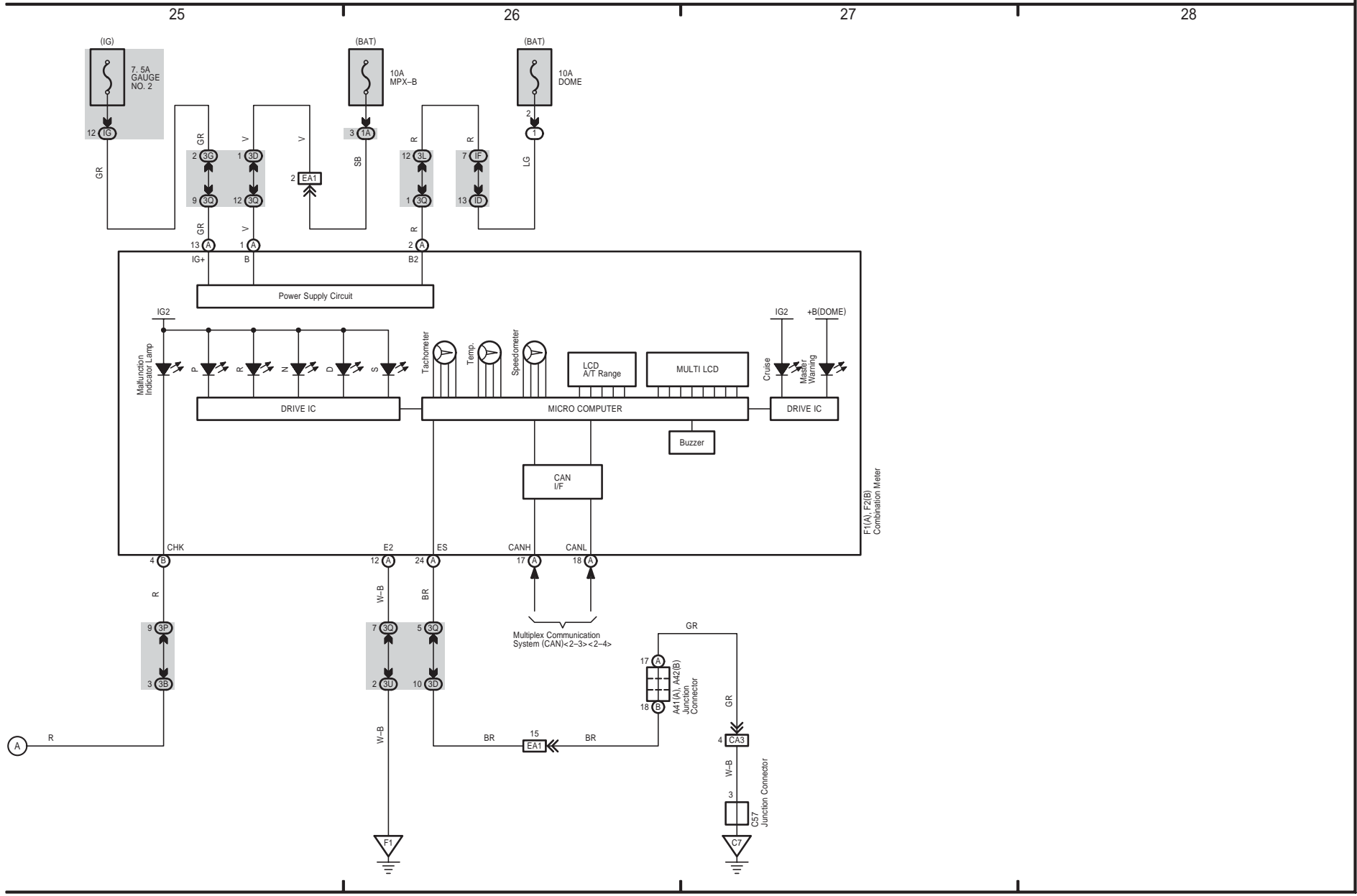



CAMRY (EM0250U)

Engine Control (2AZ-FE)

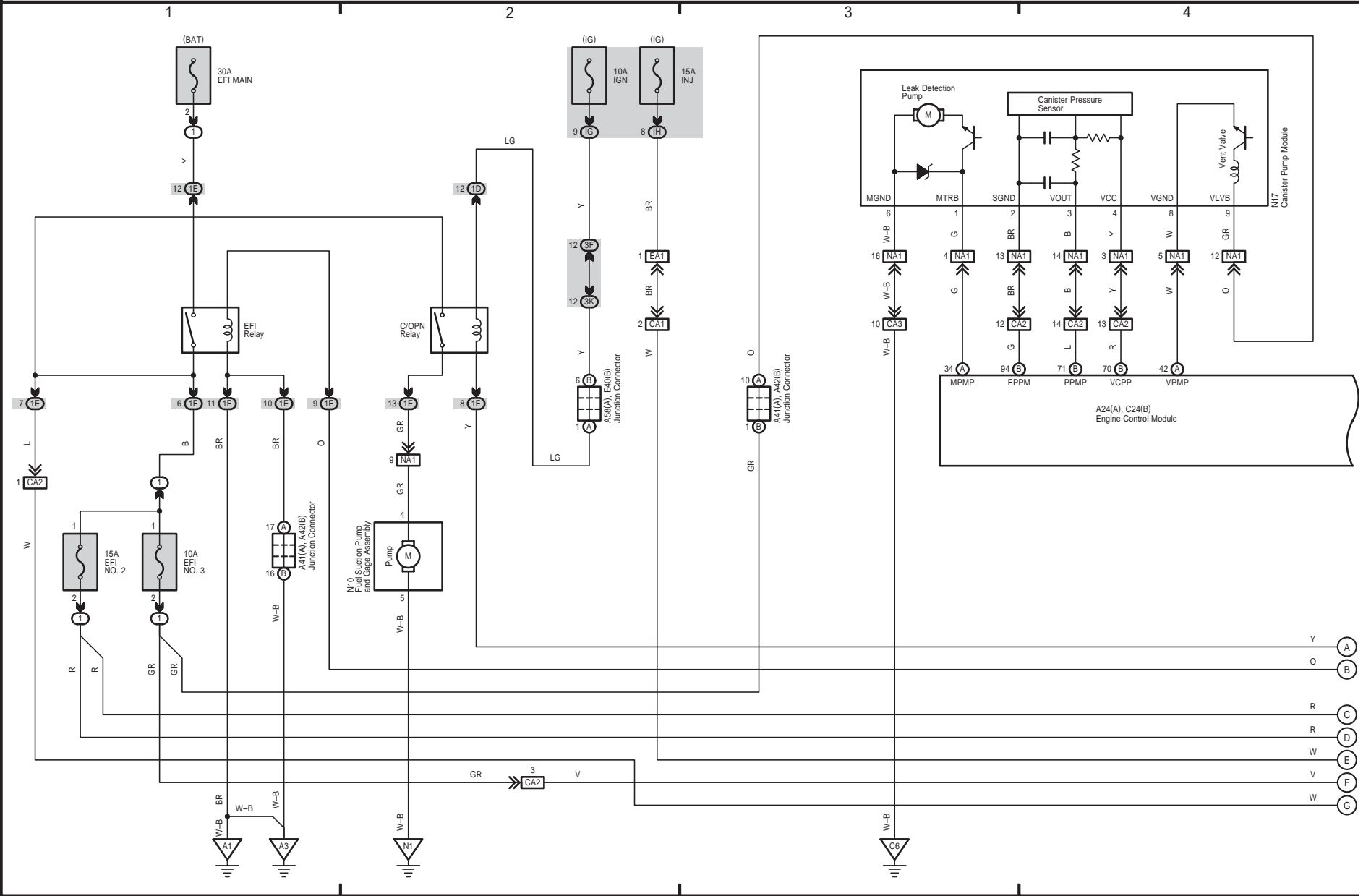

Engine Control (2AZ-FE)

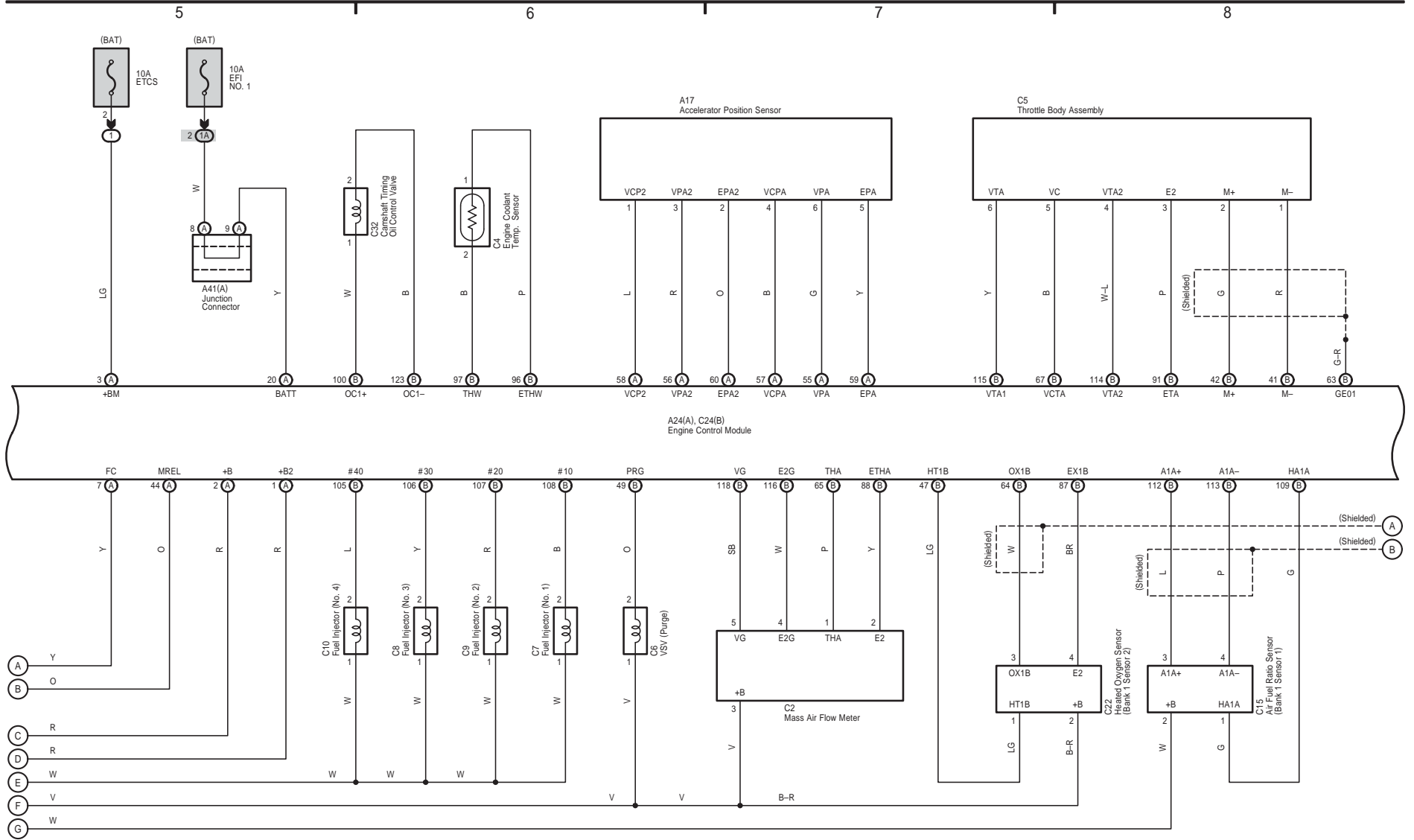

CAMRY (EM0250U)





Cruise Control (2AZ-FE)

Electronically Controlled Transmission and A/T Indicator (2AZ-FE)

13

14

15

16

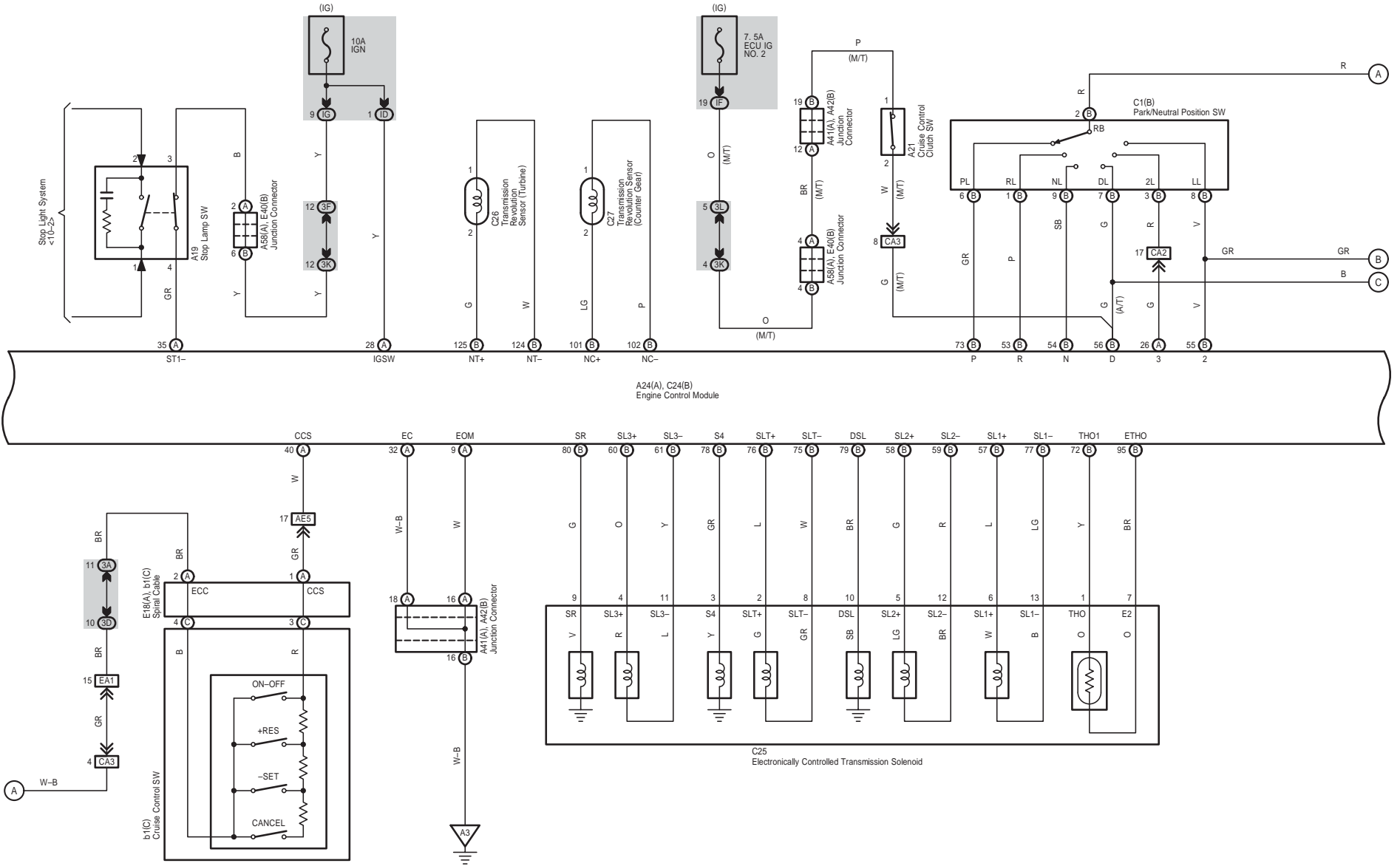

CAMRY (EM0250U)





Data Link Connector 3

Engine Immobiliser System  
(w/o Smart Key System)

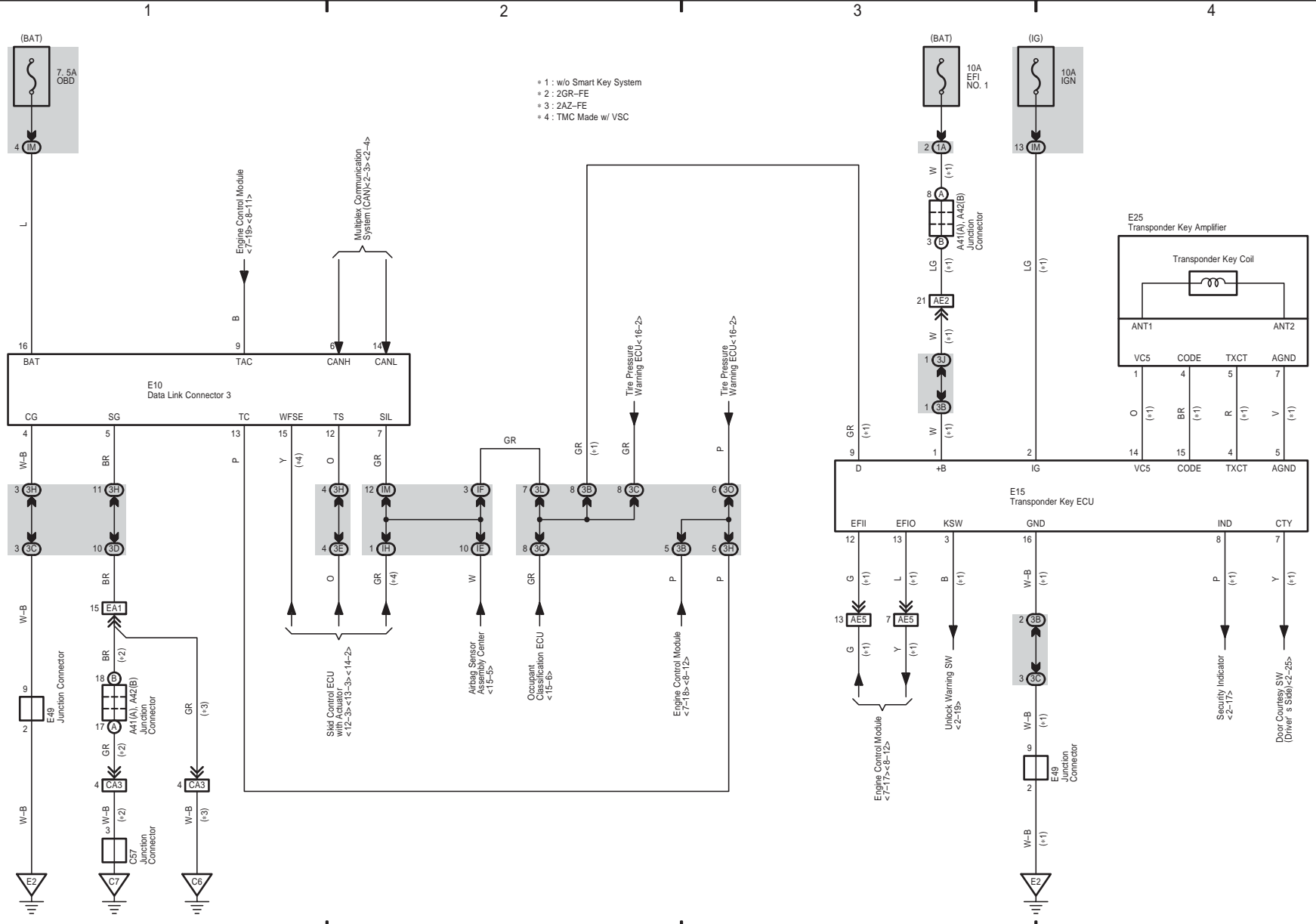





Turn Signal and Hazard Warning Light

+ 1 : 2GR-FE  
 + 2 : 2AZ-FE

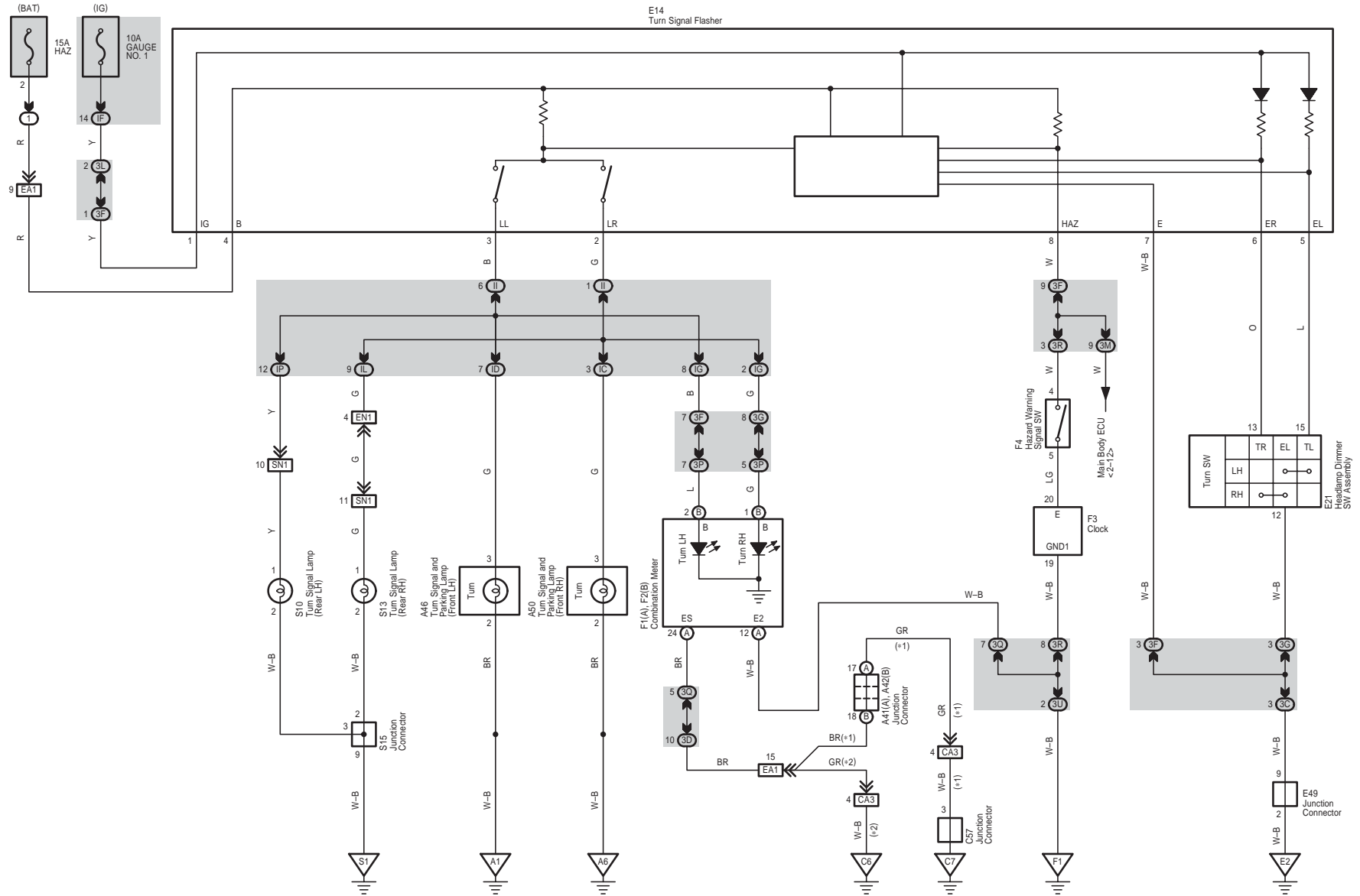

CAMRY (EM0250U)





ABS (w/ VSC), TRAC and VSC (TMC Made)

CAMRY (EM0250U)

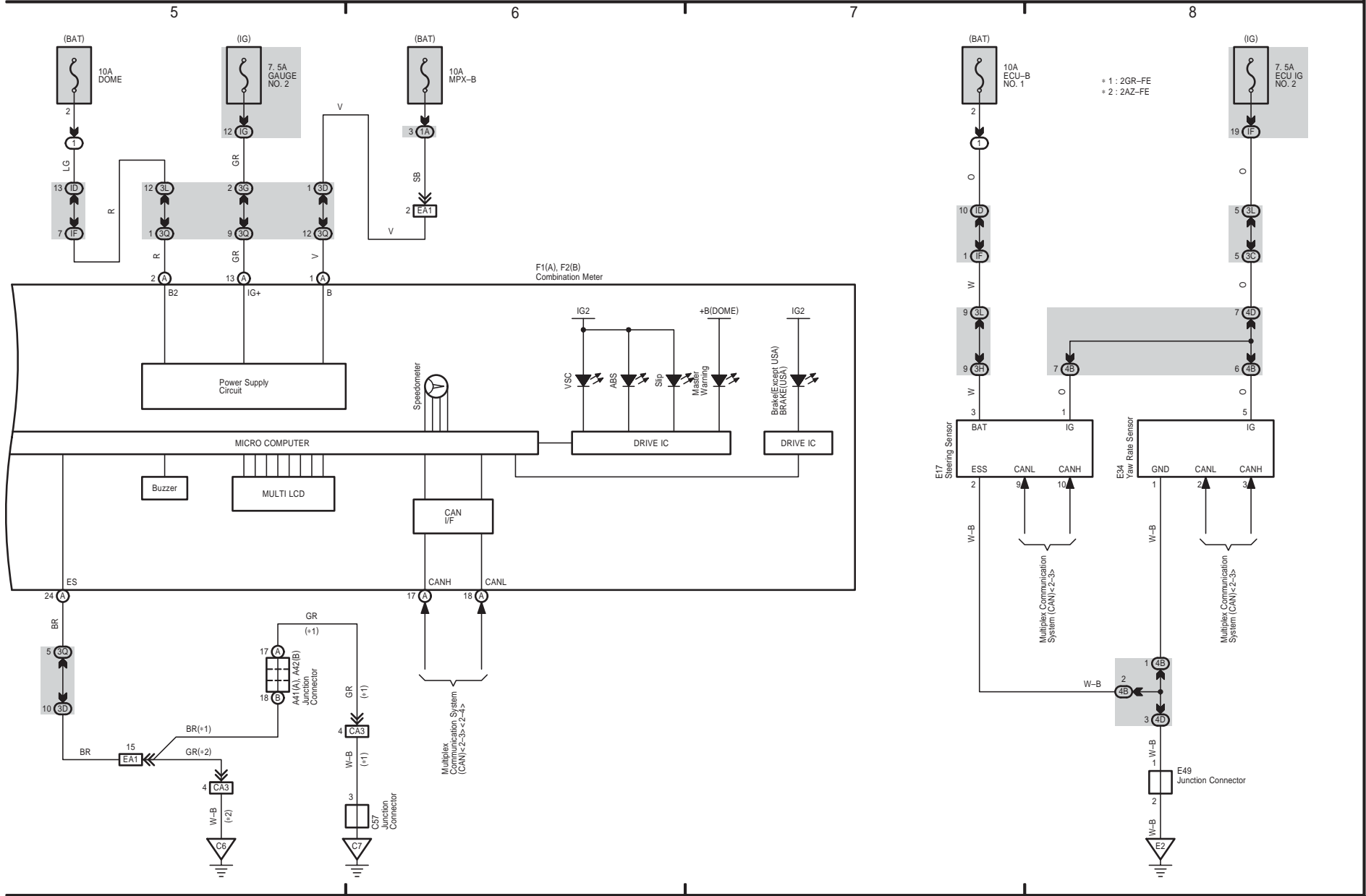

ABS (w/ VSC), TRAC and VSC (TMMK Made)

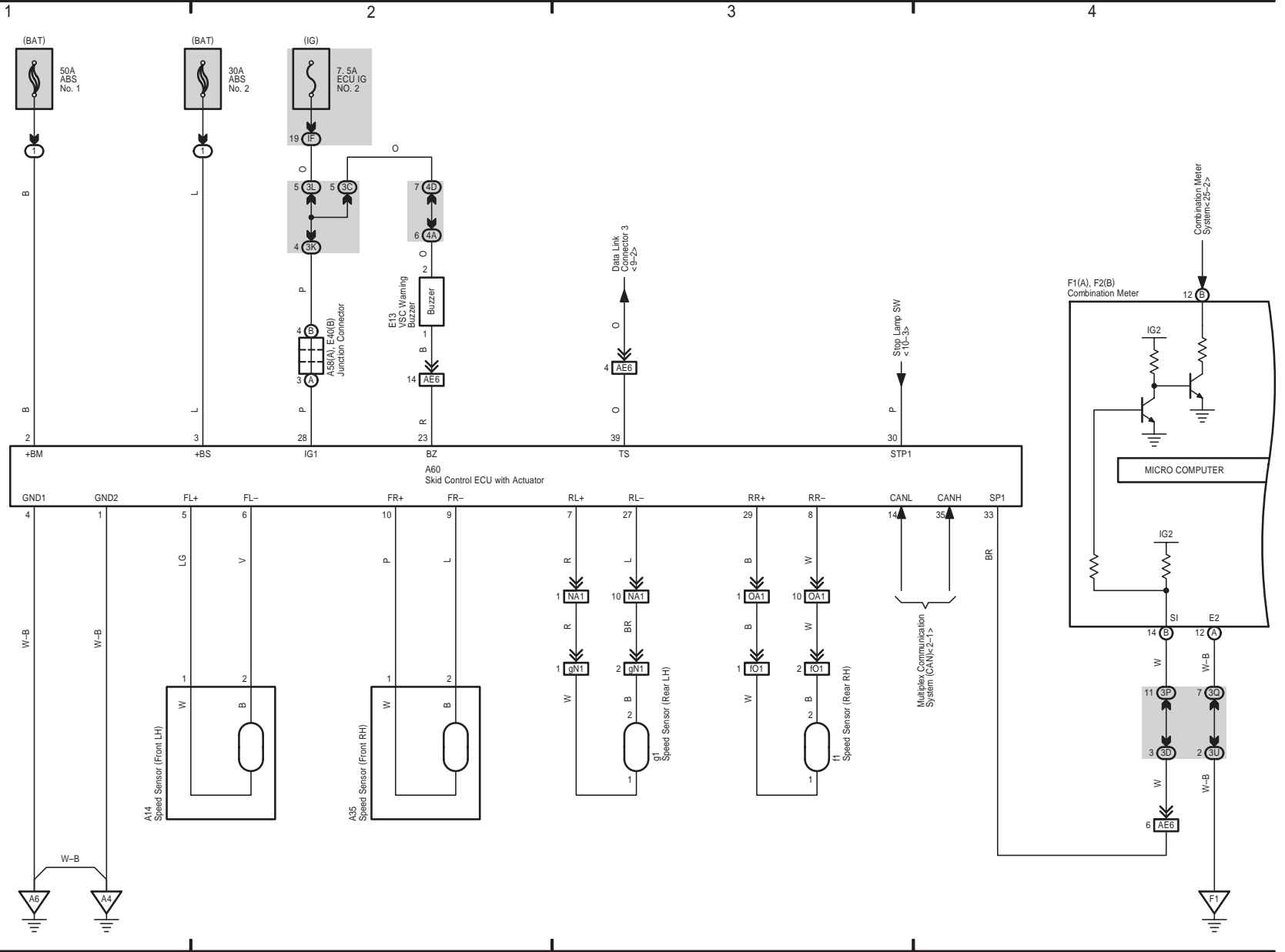

ABS (w/ VSC), TRAC and VSC (TMMK Made)

CAMRY (EM0250U)

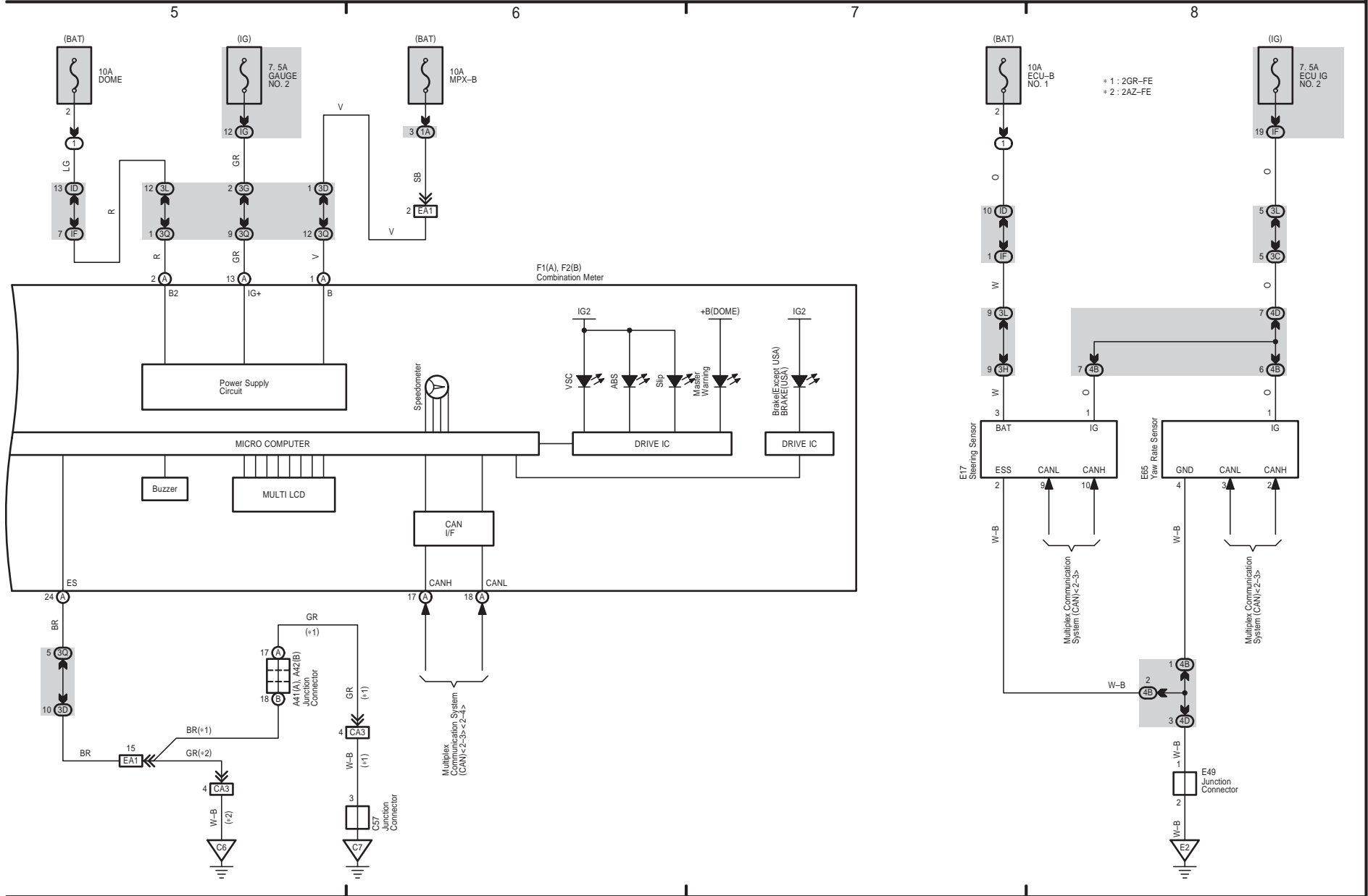

14 CAMRY

ABS (w/o VSC)

- + 1 : TMC Made
- + 2 : TMMK Made
- + 3 : 2GR-FE
- + 4 : 2AZ-FE

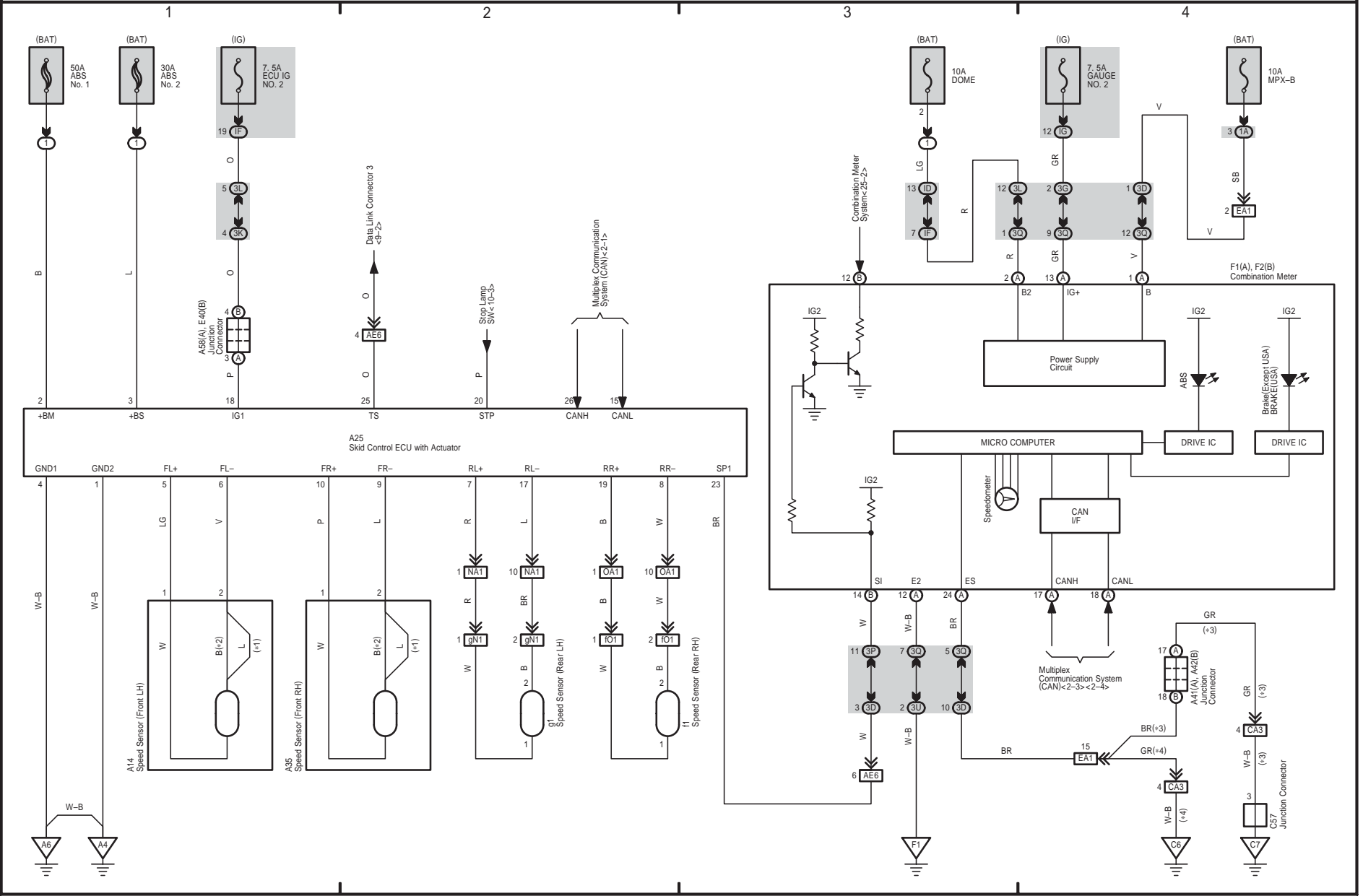

CAMRY (EM0250U)

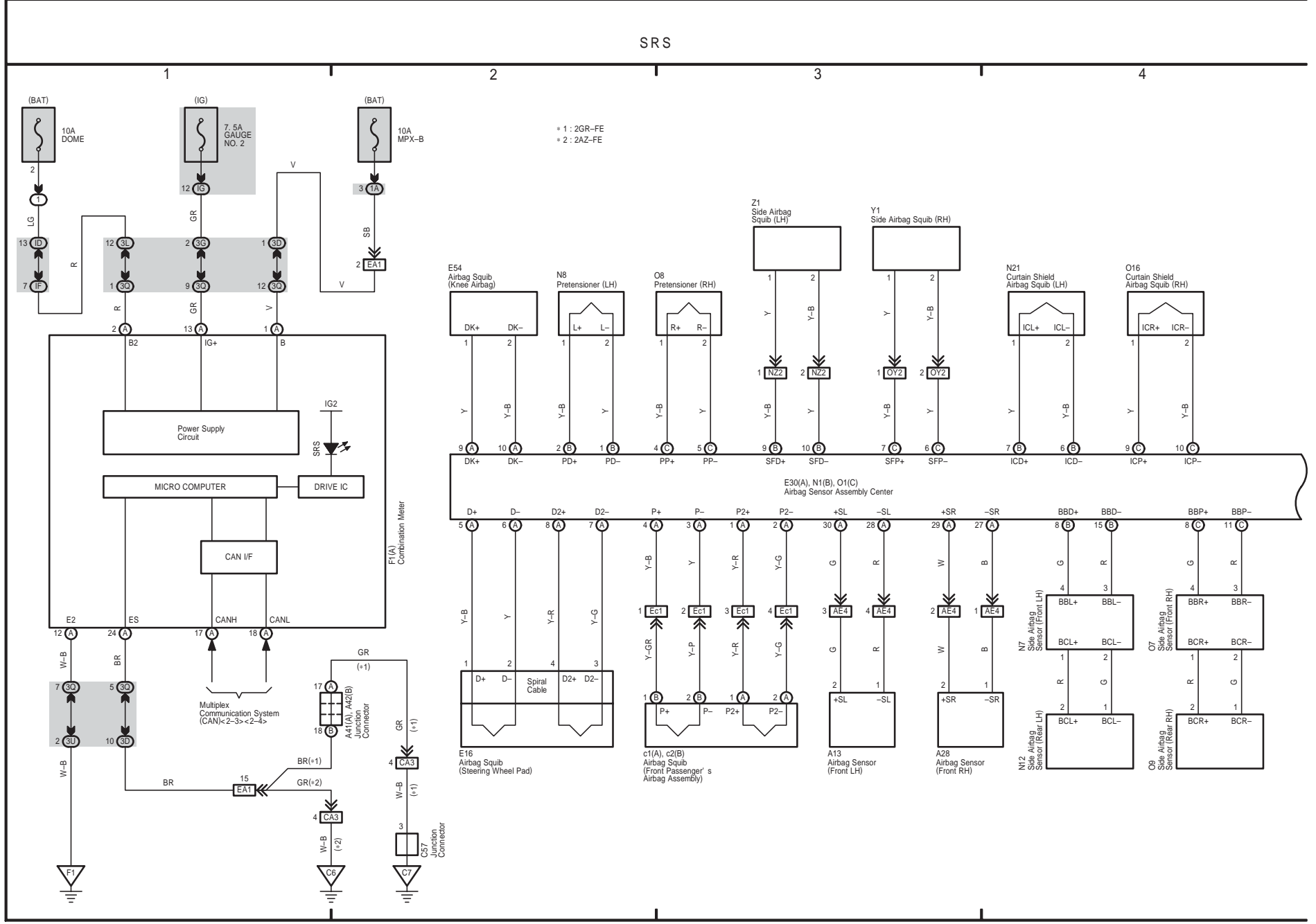



SRS

\* 3 : w/ Power Seat  
 \* 4 : w/o Power Seat

CAMRY (EM0250U)

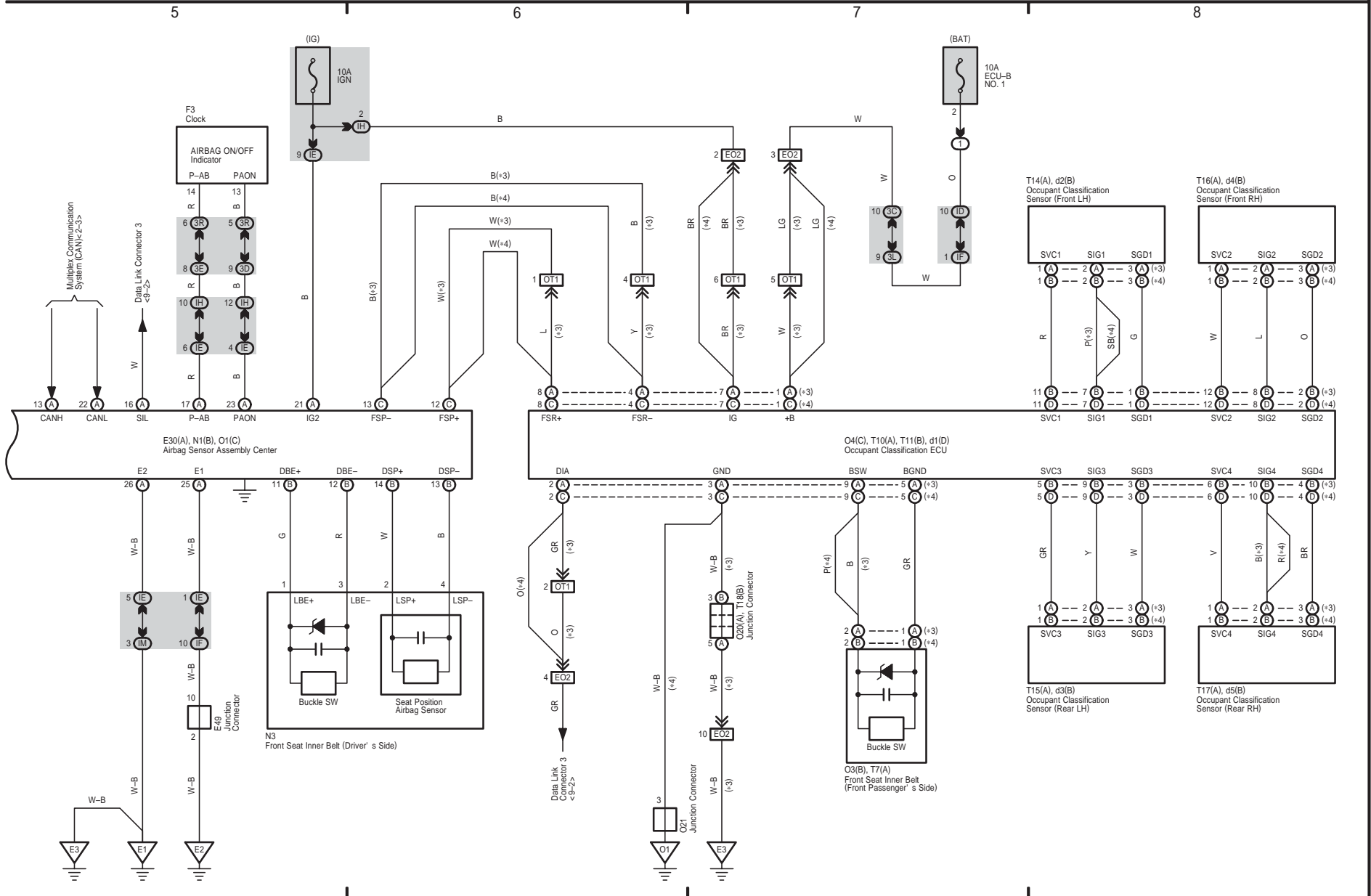

16 CAMRY

Tire Pressure Warning System

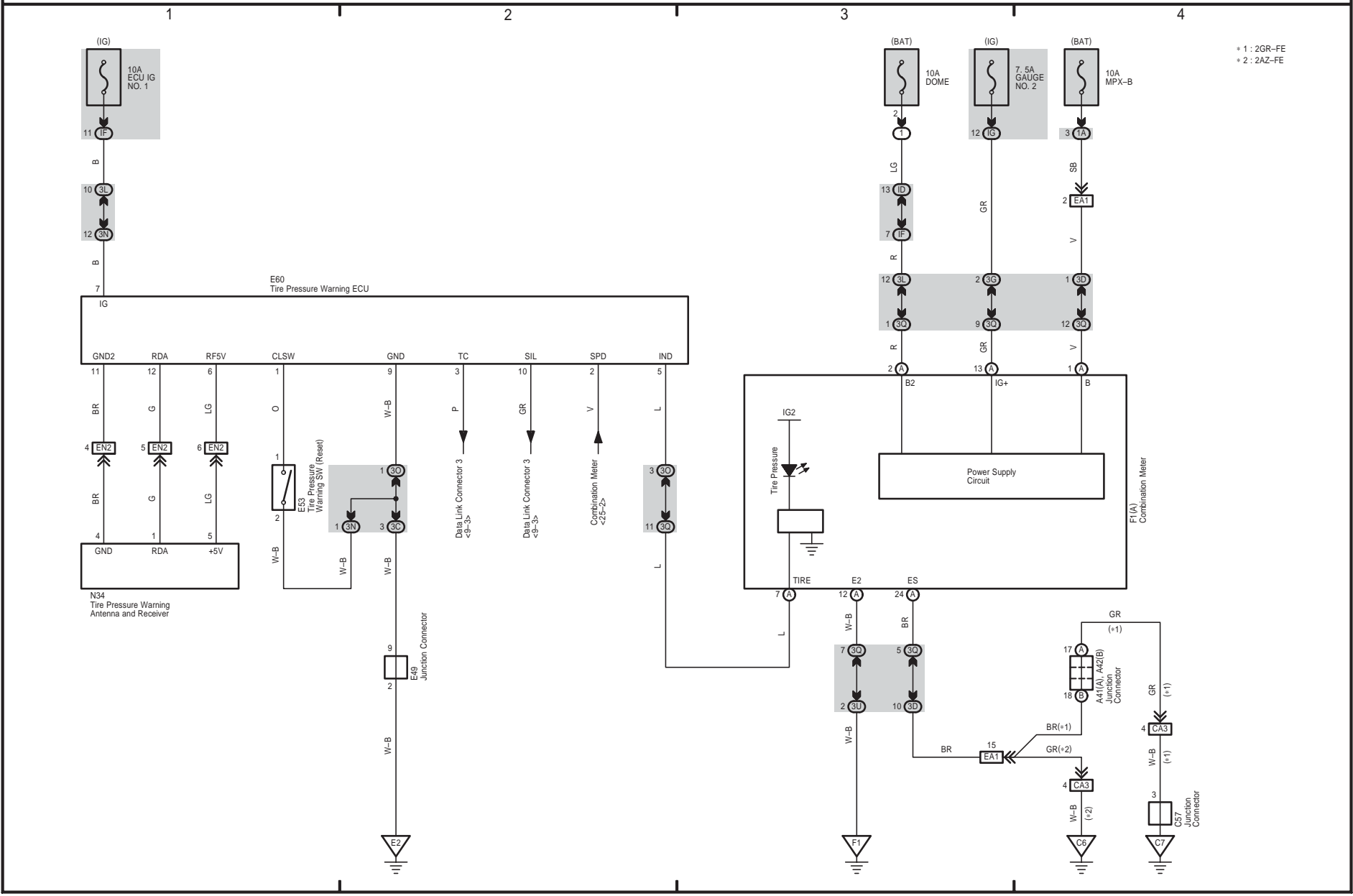

\* 1 : 2GR-FE  
\* 2 : 2AZ-FE



18 CAMRY

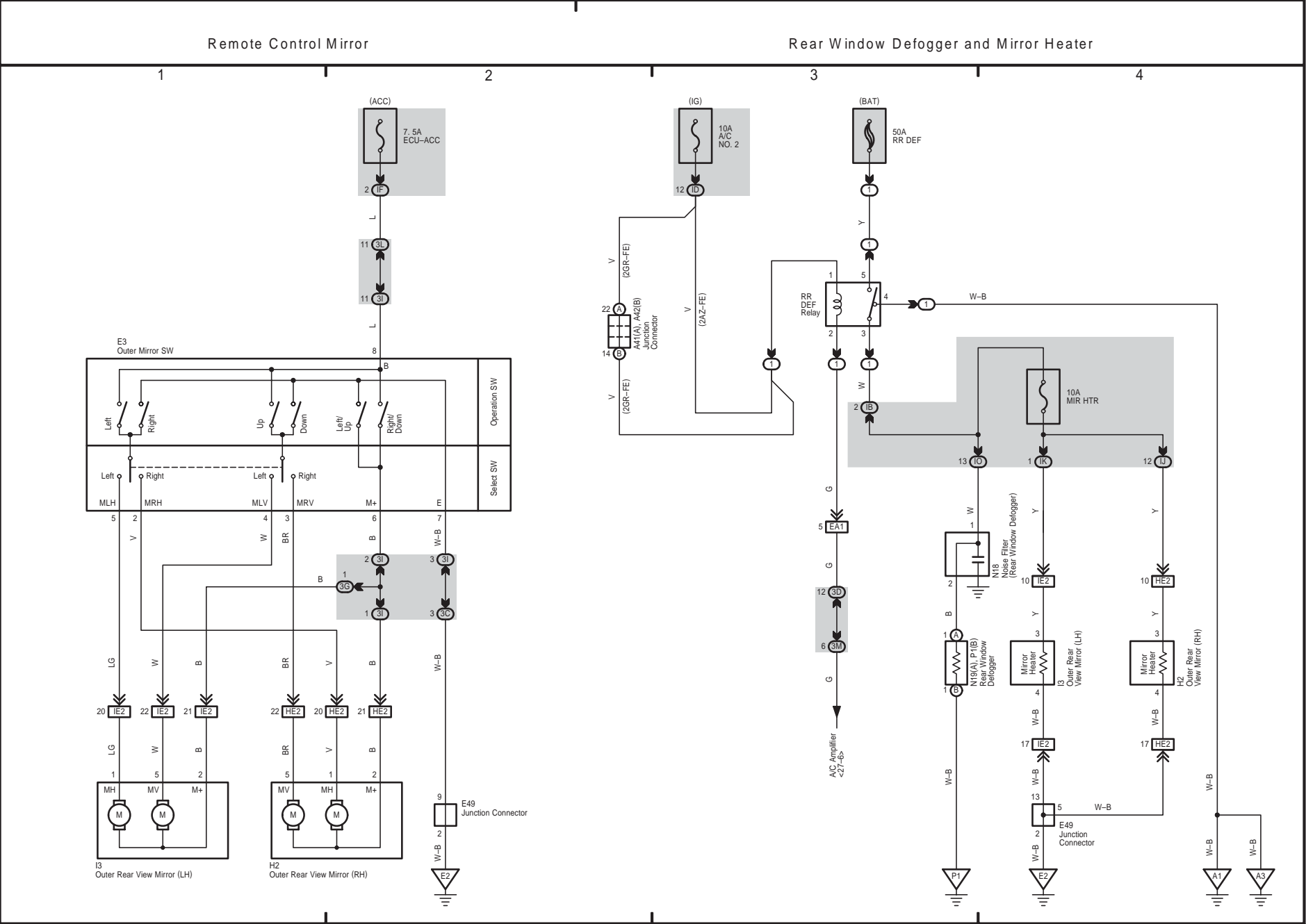



20 CAMRY

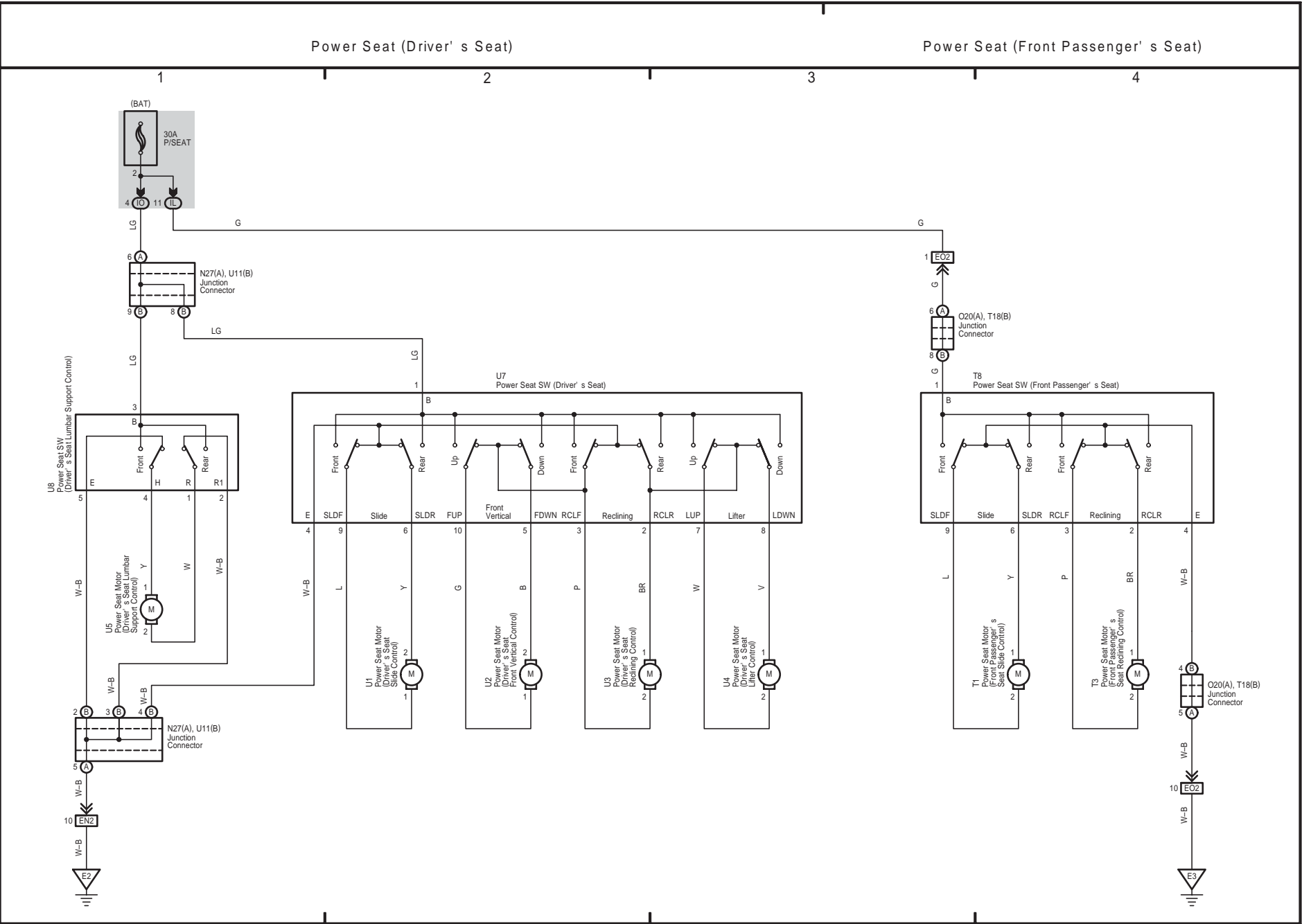

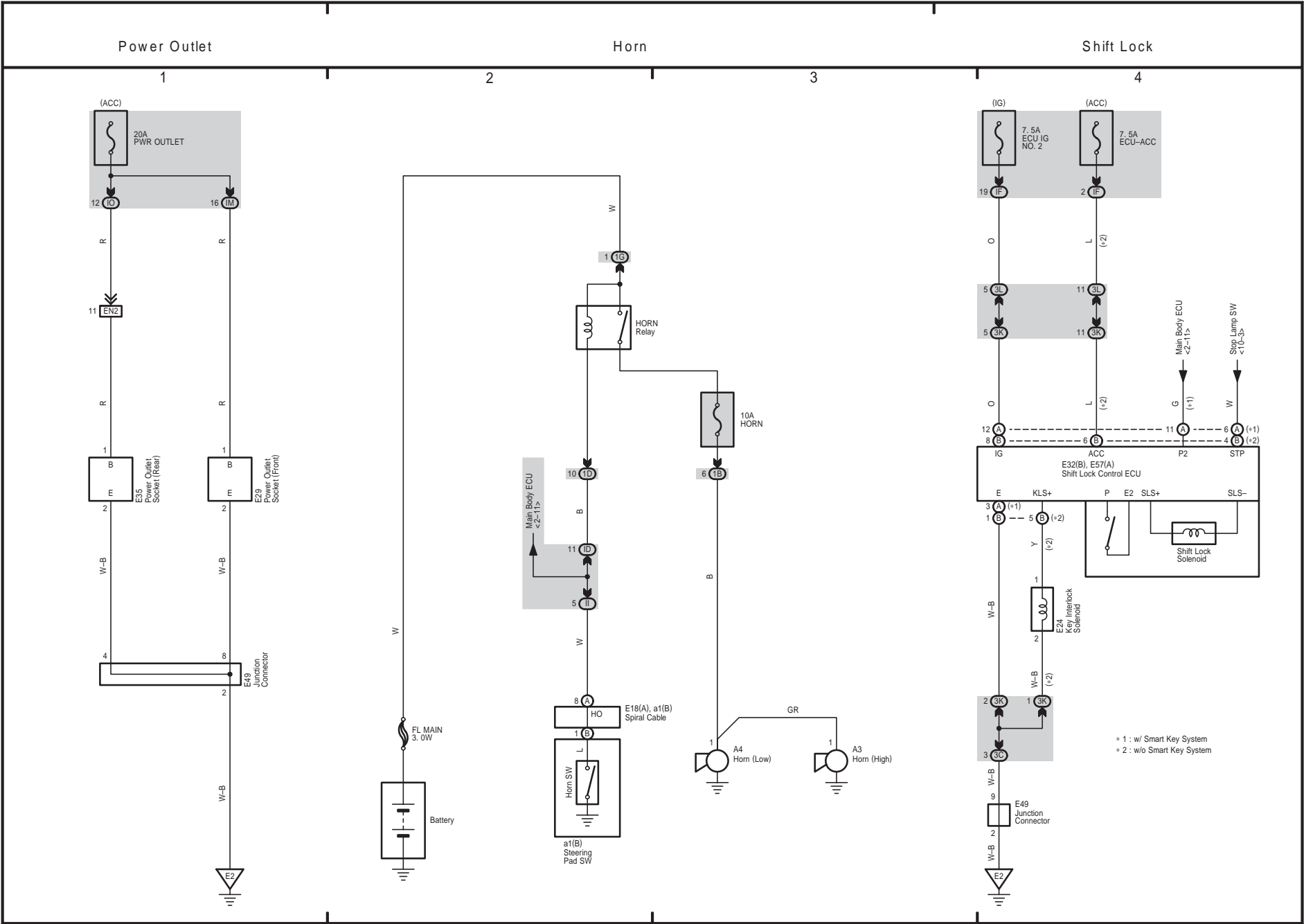

Navigation System and Audio System (8 Speaker)

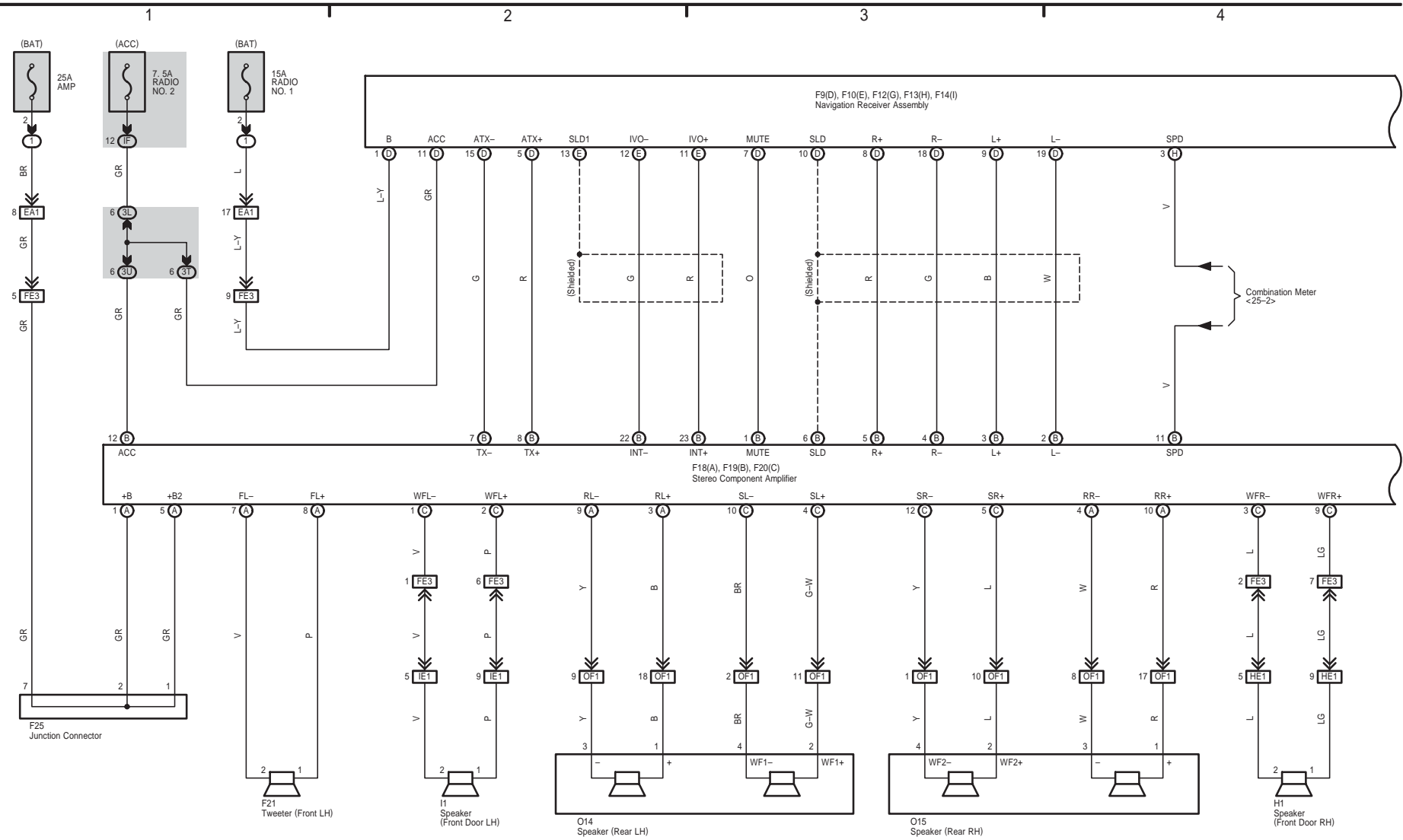



Navigation System and Audio System (8 Speaker)

\* 1 : TMC Made  
 \* 2 : TMMK Made

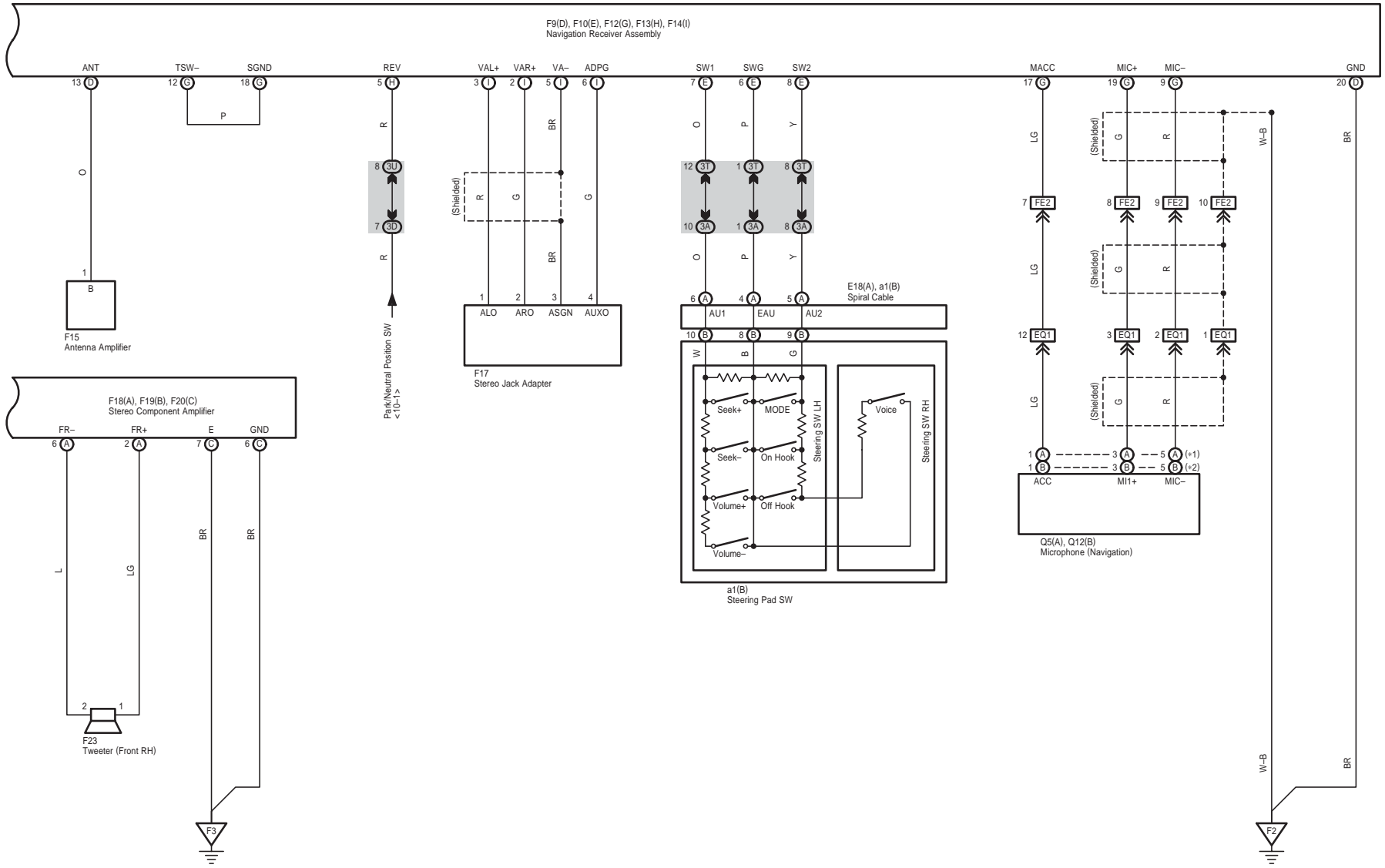

CAMRY (EM0250U)



Audio System (8 Speaker w/o Navigation System)

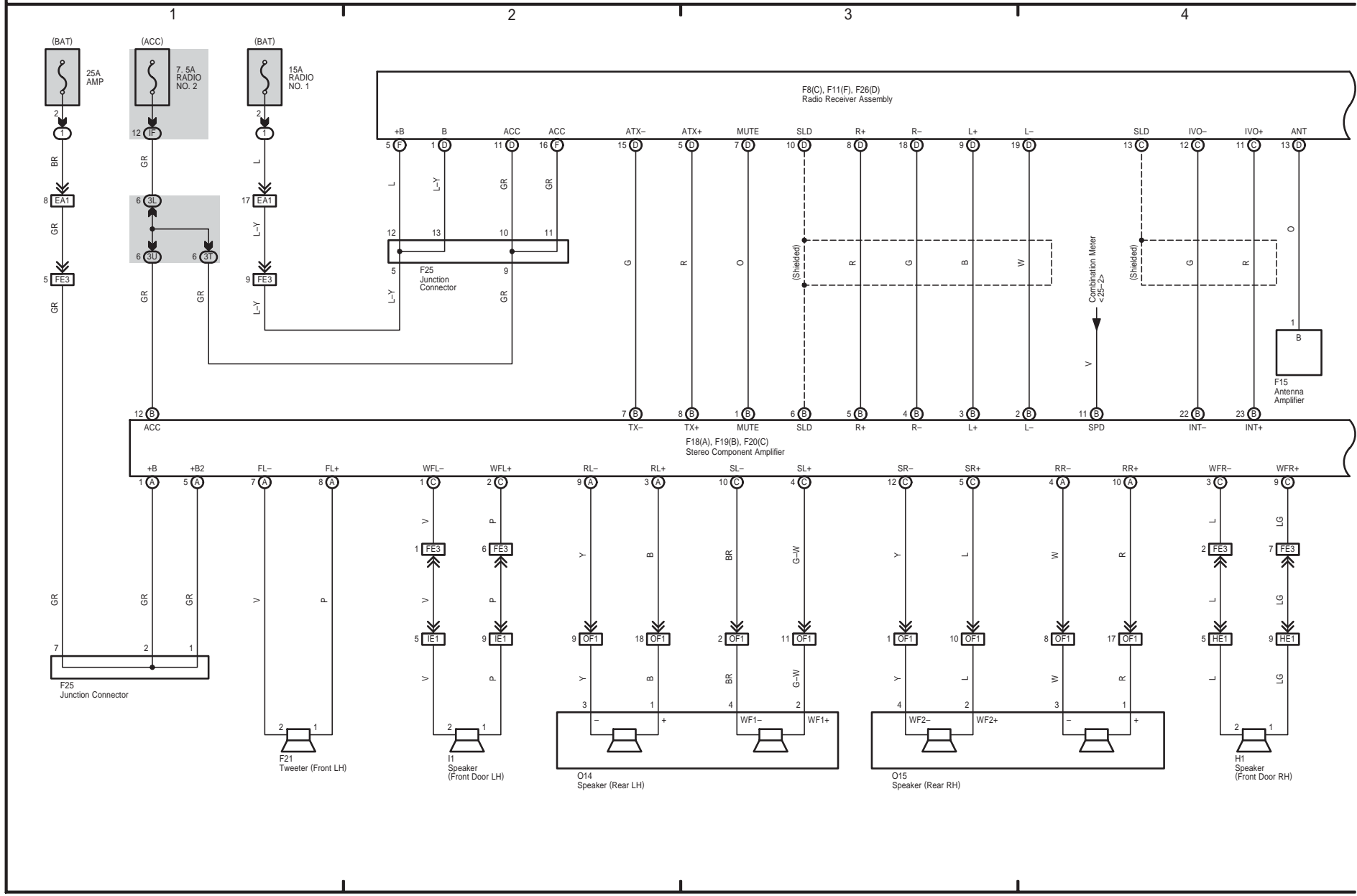

Audio System (8 Speaker w/o Navigation System)

5 6 7 8

\* 1 : TMC Made  
 \* 2 : TMMK Made

CAMRY (EM0250U)

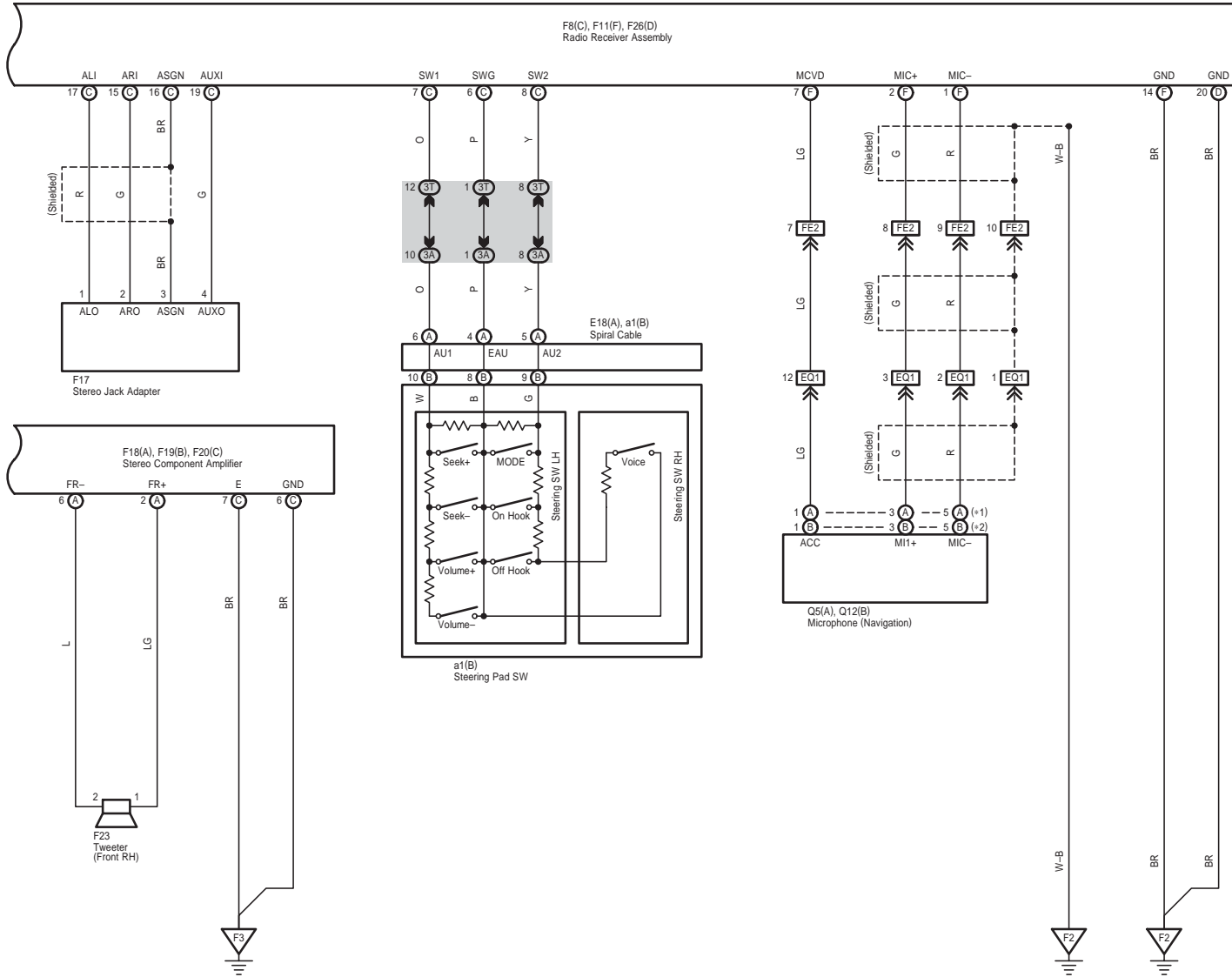

24 CAMRY

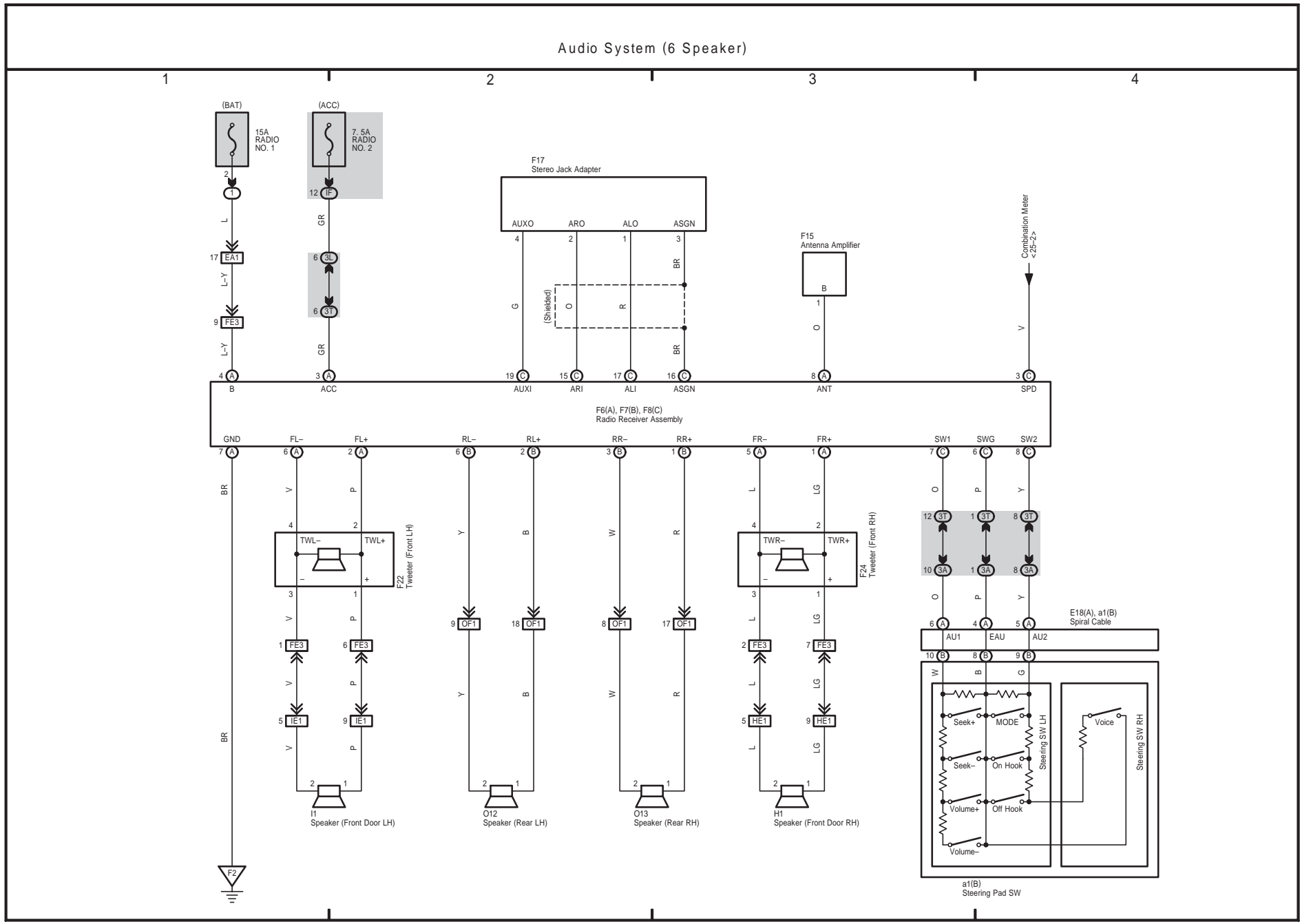

CAMRY (EM0250J)

Combination Meter

- \* 1 : 2GR-FE
- \* 2 : 2AZ-FE
- \* 3 : w/ Smart Key System
- \* 4 : 8 Speaker
- \* 5 : 6 Speaker

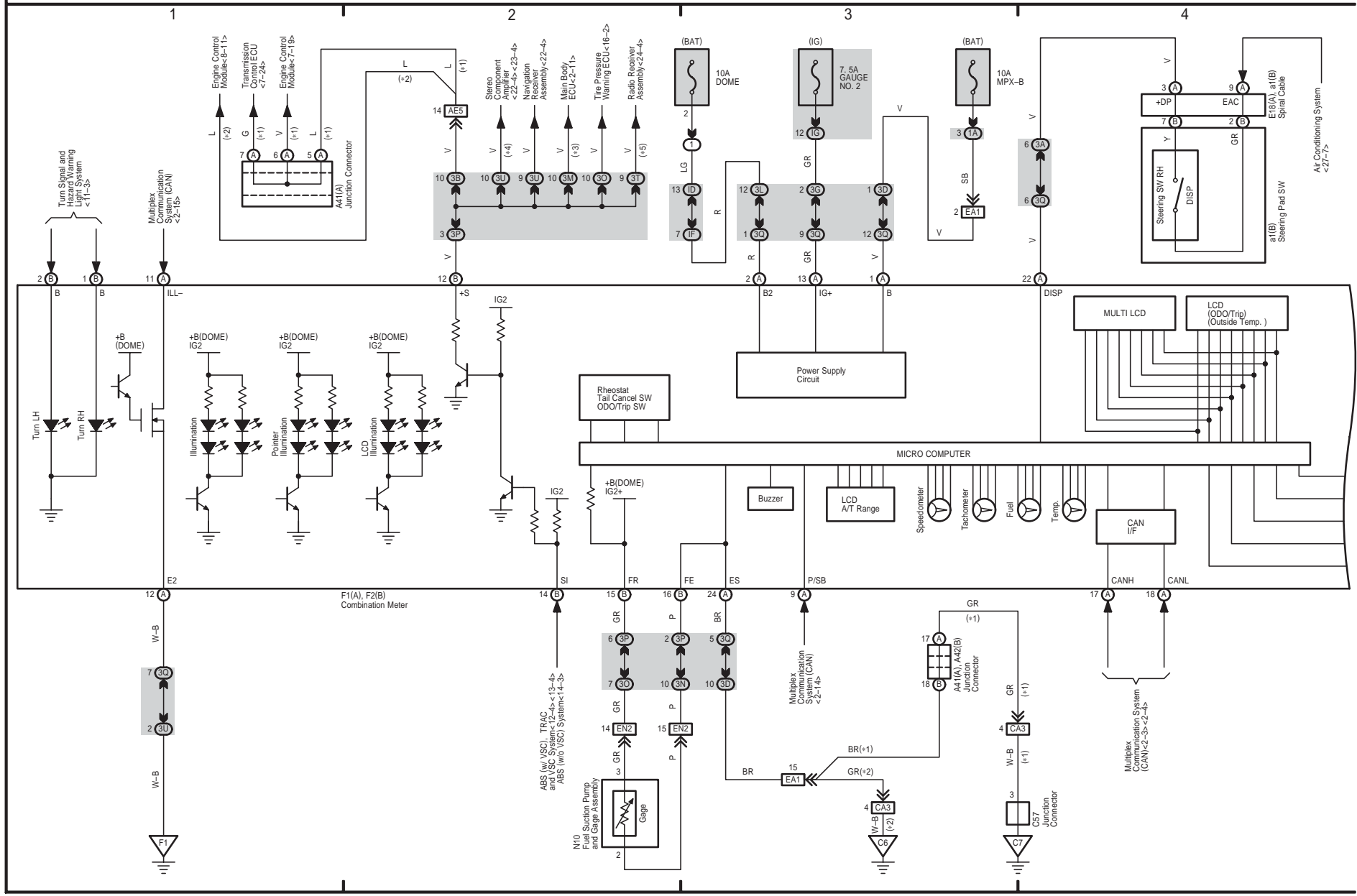

Combination Meter

5 6 7 8

CAMRY (EM0250U)

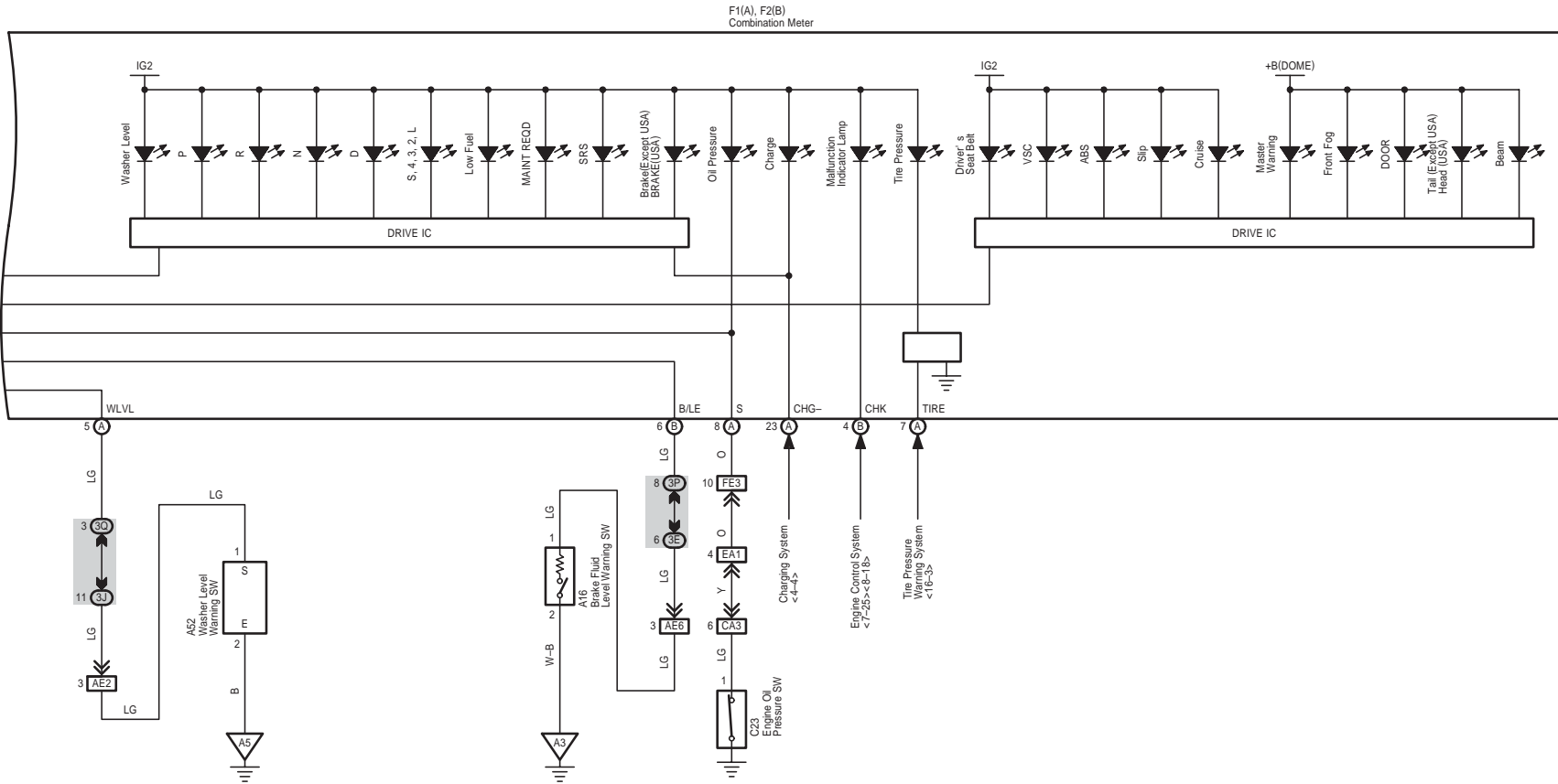

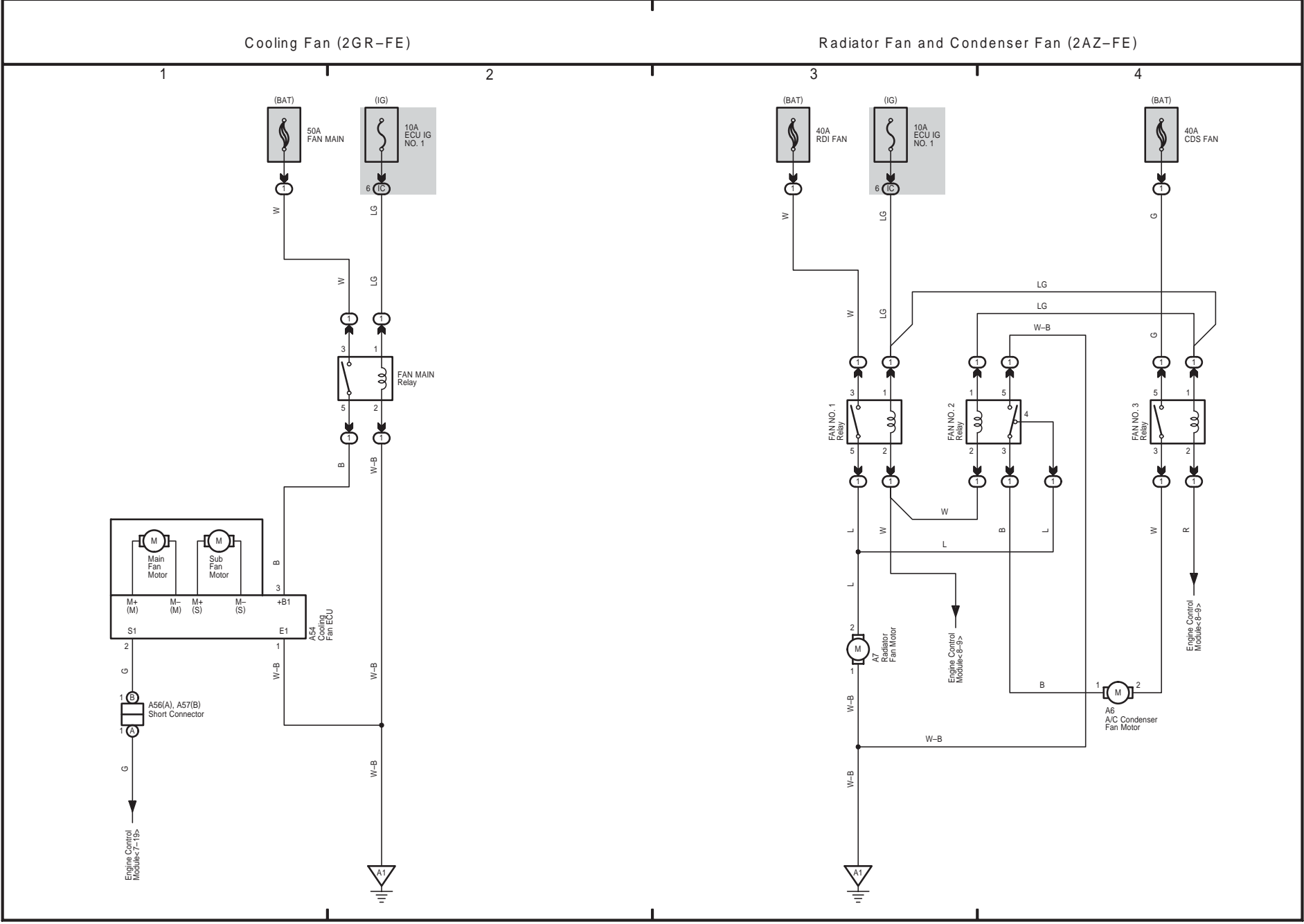



CAMRY (EM0250U)



Air Conditioning

• 2 : Automatic A/C  
• 3 : Manual A/C

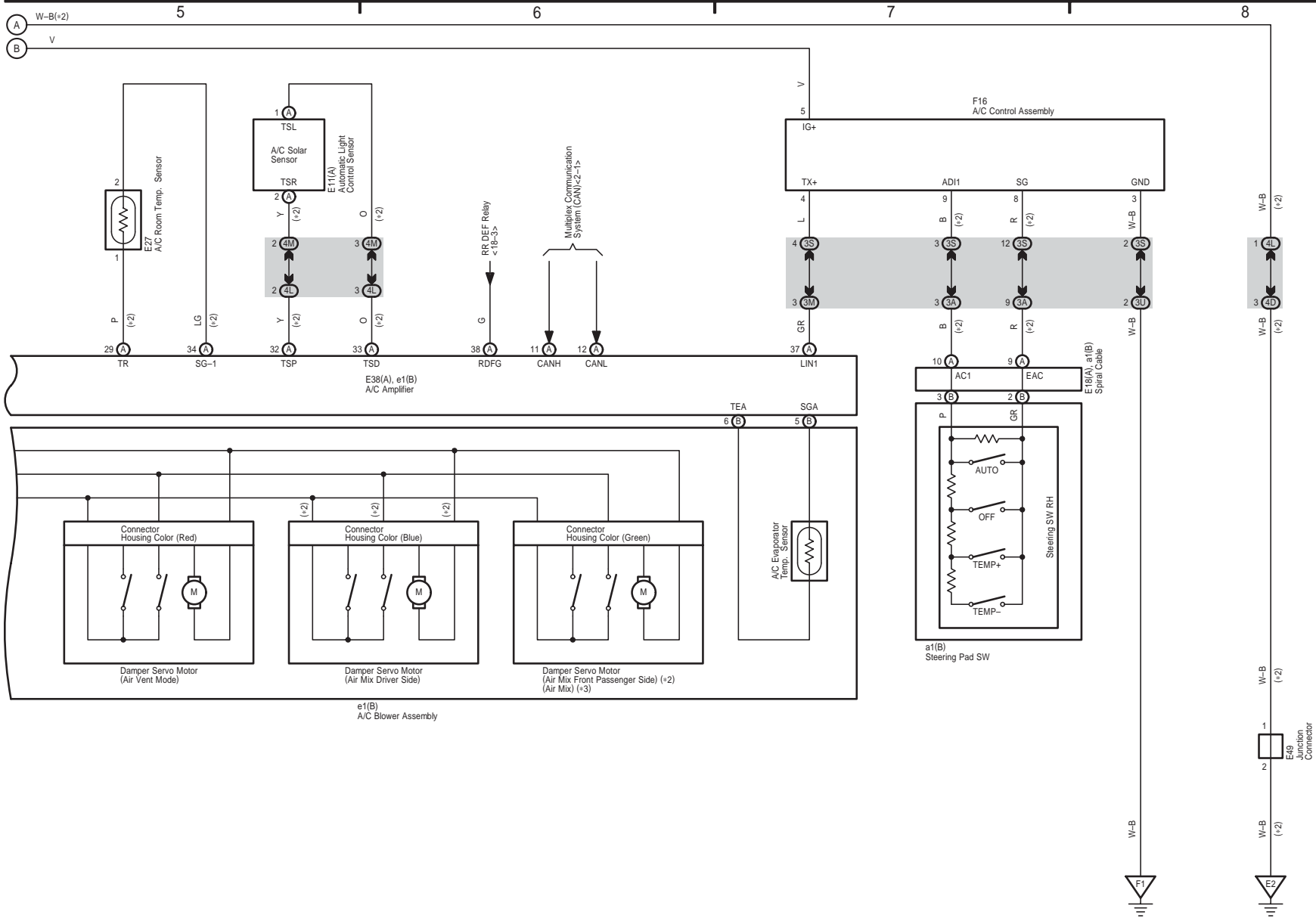

CAMRY (EM0250U)

